



AGENDA

**CITY COUNCIL OF THE CITY OF MORENO VALLEY
MORENO VALLEY COMMUNITY SERVICES DISTRICT
CITY AS SUCCESSOR AGENCY FOR THE
COMMUNITY REDEVELOPMENT AGENCY OF
THE CITY OF MORENO VALLEY
MORENO VALLEY HOUSING AUTHORITY
MORENO VALLEY PUBLIC FINANCING AUTHORITY
BOARD OF LIBRARY TRUSTEES AND THE
MORENO VALLEY COMMUNITY FOUNDATION**

October 17, 2023

REGULAR MEETING – 6:00 PM

City Council Study Sessions

Second Tuesday of each month – 6:00 p.m.

City Council Meetings

Special Presentations – 5:30 P.M.

First & Third Tuesday of each month – 6:00 p.m.

City Council Closed Sessions

Will be scheduled as needed at 4:30 p.m.

City Hall Council Chamber – 14177 Frederick Street

Upon request, this agenda will be made available in appropriate alternative formats to persons with disabilities, in compliance with the Americans with Disabilities Act of 1990. Any person with a disability who requires a modification or accommodation in order to participate in a meeting should direct such request to the ADA Coordinator, at 951.413.3350 at least 72 hours before the meeting. The 72-hour notification will enable the City to make reasonable arrangements to ensure accessibility to this meeting.

Ulises Cabrera, Mayor

Edward A. Delgado, Mayor Pro Tem

David Marquez, Council Member

Cheylynda Barnard, Council Member

Elena Baca-Santa Cruz, Council Member

AGENDA
CITY COUNCIL OF THE CITY OF MORENO VALLEY
October 17, 2023

CALL TO ORDER - 5:30 PM

SPECIAL PRESENTATIONS

1. MORENO VALLEY ROCKET TRACK TEAM RECOGNITION - COACH PHANNIX
2. HELEN PUTMAN AWARDS PRESENTATION - LAURA VARELA
3. FILIPINO AMERICAN HISTORY MONTH – PERRIS FILAM – MARIO NAZARENO
4. BREAST CANCER AWARENESS MONTH

**AGENDA
JOINT MEETING OF THE
CITY COUNCIL OF THE CITY OF MORENO VALLEY
MORENO VALLEY COMMUNITY SERVICES DISTRICT
CITY AS SUCCESSOR AGENCY FOR THE
COMMUNITY REDEVELOPMENT AGENCY OF THE
CITY OF MORENO VALLEY
MORENO VALLEY HOUSING AUTHORITY
MORENO VALLEY PUBLIC FINANCING AUTHORITY
THE BOARD OF LIBRARY TRUSTEES AND THE
MORENO VALLEY COMMUNITY FOUNDATION**

***THE CITY COUNCIL RECEIVES A SEPARATE STIPEND FOR CSD
MEETINGS***

**REGULAR MEETING – 6:00 PM
OCTOBER 17, 2023**

CALL TO ORDER

Joint Meeting of the City Council, Community Services District, City as Successor Agency for the Community Redevelopment Agency, Housing Authority, Board of Library Trustees and the Moreno Valley Community Foundation - actions taken at the Joint Meeting are those of the Agency indicated on each Agenda item.

PLEDGE OF ALLEGIANCE

INVOCATION

DR. DALE LACQUEMENT FROM FAITH SOUTHERN BAPTIST CHURCH

ROLL CALL

INTRODUCTIONS

**PUBLIC COMMENTS ON ANY SUBJECT NOT ON THE AGENDA UNDER THE
JURISDICTION OF THE CITY COUNCIL**

**PUBLIC COMMENTS ON ANY SUBJECT ON THE AGENDA UNDER THE
JURISDICTION OF THE CITY COUNCIL**

JOINT CONSENT CALENDARS (SECTIONS A-E)

All items listed under the Consent Calendars, Sections A, B, C, D, and E are considered to be routine and non-controversial, and may be enacted by one motion unless a member of the City Council, Community Services District, City as Successor Agency for the Community Redevelopment Agency, Housing Authority or the Board of Library Trustees or the Moreno Valley Community Foundation requests that an item be removed for separate action. The motion to adopt the Consent Calendars is deemed to

be a separate motion by each Agency and shall be so recorded by the City Clerk. Items withdrawn for report or discussion will be heard after public hearing items.

A. CONSENT CALENDAR-CITY COUNCIL

- A.1. ORDINANCES - READING BY TITLE ONLY - THE MOTION TO ADOPT AN ORDINANCE LISTED ON THE CONSENT CALENDAR INCLUDES WAIVER OF FULL READING OF THE ORDINANCE.

Recommendation: Waive reading of all Ordinances.

- A.2. MINUTES - CITY COUNCIL - CLOSED SESSION - OCTOBER 3, 2023 5:00 PM.

Recommendation:

1. Approve as submitted.

- A.3. MINUTES - CITY COUNCIL - REGULAR MEETING - OCTOBER 3, 2023 6:00 PM.

Recommendation:

1. Approve as submitted.

- A.4. COUNCIL DISCRETIONARY EXPENDITURE REPORTS FOR FISCAL YEAR 2023/2024 FROM JULY 1, 2023 THROUGH August 31, 2023. (Report of: City Clerk)

Recommendation:

1. Receive and file the Fiscal Year 2023/2024 Council Discretionary Expenditure Report for July 1, 2023 through August 31, 2023.

- A.5. COUNCIL TRAINING & TRAVEL EXPENDITURE REPORTS FOR FISCAL YEAR 2023-2024 (Report of: City Clerk)

Recommendation:

1. Receive and file the Training & Travel Authorization Forms for the month of September 2023.

- A.6. CONDUCT SECOND READING AND ADOPTION OF ORDINANCE NO. 1002 ADDING CHAPTER 2.66 "ELECTRONIC FILING OF CAMPAIGN DISCLOSURE STATEMENTS," RELATING TO ELECTRONIC FILING OF FAIR POLITICAL PRACTICES COMMISSION STATEMENTS (Report of: City Clerk)

Recommendation:

1. That the City Council adopt Ordinance No. 1002 - an Ordinance adding Chapter 2.66, "Electronic Filing of Campaign Disclosure Statement" to the Moreno Valley Municipal Code.

A.7. MORENO VALLEY COMMUNITY FOUNDATION - HOMELESS COMMUNITY OUTREACH PILOT PROGRAM (Report of: City Manager)

Recommendations:

1. Authorize the Vice President (Assistant City Manager) and Treasurer (CFO/Treasurer) to create the Moreno Valley Community Foundation Homeless Community Outreach Pilot Program as identified in the attached Resolution, and
2. Adopt Resolution 2023- XX describing the Community Outreach Pilot Program, and
3. Authorize the Vice President to execute any Agreements with the Community Based Organizations (CBO's) as a part of the Pilot Program and any subsequent Amendments to the Agreement within Board approved annual budgeted amounts, including the authority to authorize the associated purchase orders in accordance with the terms of the Agreement, subject to the approval of the City Attorney, and
4. Authorize the Treasurer to process a budget amendment and appropriation as shown in the Fiscal Impact section of the report.

A.8. LIST OF PERSONNEL CHANGES (Report of: Financial & Management Services)

Recommendation:

1. Ratify the list of personnel changes as described.

A.9. PAYMENT REGISTER - AUGUST 2023 (Report of: Financial & Management Services)

Recommendation:

1. Receive and file the Payment Register.

A.10. DECLARING INTENTION TO ESTABLISH COMMUNITY FACILITIES DISTRICT 2023-01 (PUBLIC SAFETY SERVICES) OF THE CITY OF MORENO VALLEY AND TO AUTHORIZE THE LEVY OF A SPECIAL TAX THEREIN (RESO. NO. 2023-XX) (Report of: Financial & Management Services)

Recommendations:

1. Adopt Resolution No. 2023-XX. A Resolution of the City Council of the City of Moreno Valley, California, Adopting Supplemental Local Goals and Policies for Community Facilities Districts to Fund Public Services.
2. Adopt Resolution No. 2023-XX. A Resolution of the City Council of the City of Moreno Valley, California, Declaring its Intention to Establish its Community Facilities District No. 2023-01 (Public Safety Services) and to Authorize the Levy of a Special Tax Therein.

A.11. APPROVE THE PUBLIC FACILITIES FEE CREDIT AGREEMENT WITH D.R. HORTON LOS ANGELES HOLDING COMPANY, INC. A CALIFORNIA CORPORATION, FOR PARKLAND IMPROVEMENTS IN TRACT 38236 (Report of: Parks & Community Services)

Recommendations: That the City Council and CSD:

Staff recommends that the Mayor and City Council and Mayor and City Council Acting in its Capacity as President and Members of the Board of Directors of the Moreno Valley Community Services District (CSD):

1. Approve the Public Facilities Fee Credit Agreement (“Agreement”) with D.R. Horton Los Angeles Holding Company, Inc. a California Corporation, for parkland improvements at Tract 38236 located north of Brodiaea Ave. and west of Oliver St.
2. Authorize the City Manager and the City Manager in the Capacity as Executive Director of the CSD to execute the Public Facilities Fee Credit Agreement with D.R. Horton Los Angeles Holding Company, Inc., for parkland improvements at Tract 38236 on behalf of the City and CSD subject to the approval by the City Attorney.

A.12. ROAD CLOSURES FOR FUN COLOR RUN (Report of: Police Department)

Recommendation:

1. Authorize the road closure of the following streets between the hours of 7:45 a.m. and 12:00 p.m. on Saturday, November 18, 2023, to control traffic and promote safety for event staff and runners:
 - a. Eastbound lanes of Alessandro Boulevard between Frederick Street and Graham Street
 - b. Graham Street between Alessandro Boulevard and Brodiaea Avenue
 - c. Brodiaea Avenue between Graham Street and Frederick Street
 - d. Frederick Street between Resource Avenue and Alessandro Boulevard
 - e. Corporate Way
 - f. Resource Way

- g. Calle San Juan De Los Lagos between Frederick Street and Veterans Way
- h. Veterans Way between Calle San Juan De Los Lagos and Alessandro Boulevard.

A.13. REPORT OF EVALUATING POTENTIAL COMMERCIAL VEHICLE PARKING ON PROLOGIS LANE (Report of: Public Works)

Recommendation:

- 1. Receive and file.

A.14. AUTHORIZATION TO AWARD AGREEMENTS TO CAV CONSULTING, HR GREEN PACIFIC, AND CWE TO PROVIDE PROFESSIONAL CONSULTING SENIOR ENGINEER AND ADMINISTRATIVE SERVICES TO CAPITAL PROJECTS DIVISION OF THE PUBLIC WORKS DEPARTMENT (Report of: Public Works)

Recommendations:

- 1. Award Agreements for Professional Consultant Services with CAV Consulting, HR Green Pacific, and CWE to provide as-needed Consultant Senior Engineer and Administrative Services related to management and implementation of Capital Improvement Plan (CIP) projects for the Capital Projects Division; and
- 2. Authorize the City Manager to execute Agreements for Professional Consultant Services with CAV Consulting, HR Green Pacific, and CWE in the combined amount of approximately \$300,000 per year for the total aggregate not-to-exceed amount of \$900,000 over the entire three-year term of the agreements, subject to the approval of the City Attorney; and
- 3. Authorize the issuance of Purchase Orders to CAV Consulting, HR Green Pacific, and CWE once the Agreements have been signed by all parties using budget approved for each project and State Gas Tax as supplement funding; and
- 4. Authorize the City Manager to execute any subsequent Amendments to the Agreements with CAV Consulting, HR Green Pacific, and CWE within Council approved annual budgeted amounts for CIP projects, including the authority to authorize the associated purchase orders in accordance with the terms of the Agreement, subject to the approval of the City Attorney.

A.15. APPROVE RESOLUTION NO. 2023-xx AUTHORIZING SUBMITTAL OF APPLICATION(S) FOR ALL CALRECYCLE GRANTS FOR WHICH THE CITY OF MORENO VALLEY IS ELIGIBLE (Report of: Public Works)

Recommendation:

- 1. Adopt the proposed Resolution No. 2023-XX approving submittal of

application(s) for all CalRecycle grants for which the City of Moreno Valley is eligible.

B. CONSENT CALENDAR-COMMUNITY SERVICES DISTRICT

- B.1. ORDINANCES - READING BY TITLE ONLY - THE MOTION TO ADOPT AN ORDINANCE LISTED ON THE CONSENT CALENDAR INCLUDES WAIVER OF FULL READING OF THE ORDINANCE.

Recommendation: Waive reading of all Ordinances.

- B.2. MINUTES - CITY COUNCIL - CLOSED SESSION - OCTOBER 3, 2023 5:00 PM.

Recommendation:

1. Approve as submitted.

- B.3. MINUTES - CITY COUNCIL - REGULAR MEETING - OCTOBER 3, 2023 6:00 PM.

Recommendation:

1. Approve as submitted.

C. CONSENT CALENDAR - HOUSING AUTHORITY

- C.1. ORDINANCES - READING BY TITLE ONLY - THE MOTION TO ADOPT AN ORDINANCE LISTED ON THE CONSENT CALENDAR INCLUDES WAIVER OF FULL READING OF THE ORDINANCE.

Recommendation: Waive reading of all Ordinances.

- C.2. MINUTES - CITY COUNCIL - CLOSED SESSION - OCTOBER 3, 2023 5:00 PM.

Recommendation:

1. Approve as submitted.

- C.3. MINUTES - CITY COUNCIL - REGULAR MEETING - OCTOBER 3, 2023 6:00 PM.

Recommendation:

1. Approve as submitted.

D. CONSENT CALENDAR - BOARD OF LIBRARY TRUSTEES

- D.1. ORDINANCES - READING BY TITLE ONLY - THE MOTION TO ADOPT AN ORDINANCE LISTED ON THE CONSENT CALENDAR INCLUDES WAIVER OF FULL READING OF THE ORDINANCE.

Recommendation: Waive reading of all Ordinances.

- D.2. MINUTES - CITY COUNCIL - CLOSED SESSION - OCTOBER 3, 2023 5:00 PM.

Recommendation:

1. Approve as submitted.

- D.3. MINUTES - CITY COUNCIL - REGULAR MEETING - OCTOBER 3, 2023 6:00 PM.

Recommendation:

1. Approve as submitted.

E. CONSENT CALENDAR - PUBLIC FINANCING AUTHORITY

- E.1. ORDINANCES - READING BY TITLE ONLY - THE MOTION TO ADOPT AN ORDINANCE LISTED ON THE CONSENT CALENDAR INCLUDES WAIVER OF FULL READING OF THE ORDINANCE.

Recommendation: Waive reading of all Ordinances.

- E.2. MINUTES - CITY COUNCIL - CLOSED SESSION - OCTOBER 3, 2023 5:00 PM.

Recommendation:

1. Approve as submitted.

- E.3. MINUTES - CITY COUNCIL - REGULAR MEETING - OCTOBER 3, 2023 6:00 PM.

Recommendation:

1. Approve as submitted.

F. PUBLIC HEARINGS

Questions or comments from the public on a Public Hearing matter are limited to five minutes per individual and must pertain to the subject under consideration.

Those wishing to speak should complete and submit a GOLDENROD speaker slip to the Sergeant-at-Arms.

G. ITEMS REMOVED FROM CONSENT CALENDARS FOR DISCUSSION OR SEPARATE ACTION

H. GENERAL BUSINESS

H.1. ADOPTION OF COUNTY ORDINANCE NUMBER 987 REGARDING UNLAWFUL POSSESSION OF CATALYTIC CONVERTERS (ORD. NO. xxxx) (Report of: City Manager)

Recommendations: That the City Council:

1. Introduce and conduct first reading of Ordinance No. XXXX, amending Title 11 of the City of Moreno Valley Municipal Code, adding Chapter 11.97, adopting by reference Riverside County Ordinance No. 987; and
2. Schedule a public hearing to receive public input regarding adoption of Ordinance No. XXXX on November 21, 2023, and consider adoption of Ordinance No. XXXX upon conclusion of said public hearing.

I. REPORTS

I.1. CITY COUNCIL REPORTS

(Informational Oral Presentation - not for Council action)

March Joint Powers Commission (JPC)

Riverside County Habitat Conservation Agency (RCHCA)

Riverside County Transportation Commission (RCTC)

Riverside Transit Agency (RTA)

Western Riverside Council of Governments (WRCOG)

Western Riverside County Regional Conservation Authority (RCA)

School District/City Joint Task Force

I.2. EMPLOYEE ASSOCIATION REPORTS

I.3. CITY MANAGER'S REPORT

(Informational Oral Presentation - not for Council action)

CLOSING COMMENTS AND/OR REPORTS OF THE CITY COUNCIL, COMMUNITY SERVICES DISTRICT, CITY AS SUCCESSOR AGENCY FOR THE COMMUNITY REDEVELOPMENT AGENCY, HOUSING AUTHORITY, PUBLIC FINANCING

**AUTHORITY, THE BOARD OF LIBRARY TRUSTEES AND THE MORENO VALLEY
COMMUNITY FOUNDATION**

ADJOURNMENT

PUBLIC INSPECTION

The contents of the agenda packet are available for public inspection on the City's website at www.moval.org and in the City Clerk's office at 14177 Frederick Street during normal business hours.

Any written information related to an open session agenda item that is known by the City to have been distributed to all or a majority of the City Council less than 72 hours prior to this meeting will be made available for public inspection on the City's website at www.moval.org and in the City Clerk's office at 14177 Frederick Street during normal business hours.

CERTIFICATION

I, Jane Halstead, City Clerk of the City of Moreno Valley, California, certify that 72 hours prior to this Regular Meeting, the City Council Agenda was posted on the City's website at: www.moval.org and in the following three public places pursuant to City of Moreno Valley Resolution No. 2007-40:

City Hall, City of Moreno Valley
14177 Frederick Street

Moreno Valley Library
25480 Alessandro Boulevard

Moreno Valley Senior/Community Center
25075 Fir Avenue

Jane Halstead, CMC
City Clerk

Date Posted: 10/12/23

**MINUTES
CITY COUNCIL OF THE CITY OF MORENO VALLEY
MORENO VALLEY COMMUNITY SERVICES DISTRICT
CITY AS SUCCESSOR AGENCY FOR THE
COMMUNITY REDEVELOPMENT AGENCY OF THE
CITY OF MORENO VALLEY
MORENO VALLEY PUBLIC FINANCING AUTHORITY
MORENO VALLEY HOUSING AUTHORITY**

**CLOSED SESSION – 5:00 PM
October 3, 2023**

CALL TO ORDER

The Closed Session of the City Council of the City of Moreno Valley, Moreno Valley Community Services District, City as Successor Agency for the Community Redevelopment Agency of the City of Moreno Valley, Housing Authority, and the Moreno Valley Public Financing Authority was called to order at 5:04 p.m. by Mayor Cabrera in the Council Chamber located at 14177 Frederick Street, Moreno Valley, California.

Mayor Cabrera announced that the City Council receives a separate stipend for CSD meetings.

ROLL CALL

Council:	Ulises Cabrera	Mayor
	Ed Delgado	Mayor Pro Tem
	David Marquez	Council Member
	Cheylynda Barnard	Council Member
	Elena Baca-Santa Cruz	Council Member

PUBLIC COMMENTS ON MATTERS ON THE AGENDA ONLY

Mayor Cabrera opened the public comments portion of the meeting for items listed on the agenda only. There being no members of the public to come forward to speak, he closed the public comments.

Minutes Acceptance: Minutes of Oct 3, 2023 5:00 PM (CONSENT CALENDAR-CITY COUNCIL)

CLOSED SESSION

Assistant City Attorney Kirkpatrick announced that the City Council would recess to Closed Session to discuss the item as listed on the agenda and that he did anticipate reportable action.

A CONFERENCE WITH LEGAL COUNSEL - SIGNIFICANT EXPOSURE TO LITIGATION

Pursuant to Government Code Section 54956.9 (d)(2) (1 Potential Case)

Mayor Cabrera recessed the City Council to the City Manager's Conference Room, second floor, City Hall, for their Closed Session at 5:06 p.m.

Mayor Cabrera reconvened the City Council in the Council Chamber from their Closed Session at 5:30 p.m.

REPORT OF ACTION FROM CLOSED SESSION, IF ANY, BY CITY ATTORNEY

Assistant City Attorney Kirkpatrick announced that there was no reportable action taken in Closed Session.

ADJOURNMENT

There being no further business to come before the City Council, Mayor Cabrera adjourned the meeting at 5:32 p.m.

Submitted by:

Jane Halstead, CMC
 City Clerk
 Secretary, Moreno Valley Community Services District
 Secretary, City as Successor Agency for the Community
 Redevelopment Agency of the City of Moreno Valley
 Secretary, Moreno Valley Housing Authority
 Secretary, Board of Library Trustees
 Secretary, Public Financing Authority

Approved by:

Ulises Cabrera
 Mayor
 City of Moreno Valley
 President, Moreno Valley Community Services District
 Chairperson, City as Successor Agency for the Community
 Redevelopment Agency of the City of Moreno Valley
 Chairperson, Moreno Valley Housing Authority
 Chairperson, Board of Library Trustees
 Chairperson, Public Financing Authority

**MINUTES
CITY COUNCIL REGULAR MEETING OF THE CITY OF MORENO VALLEY
October 3, 2023**

CALL TO ORDER - 5:30 PM

SPECIAL PRESENTATIONS

NATIONAL FIRE PREVENTION WEEK OCTOBER 8 - 14, 2023

PROCLAMATION RECOGNIZING HISPANIC HERITAGE MONTH

Minutes Acceptance: Minutes of Oct 3, 2023 6:00 PM (CONSENT CALENDAR-CITY COUNCIL)

**MINUTES
JOINT MEETING OF THE
CITY COUNCIL OF THE CITY OF MORENO VALLEY
MORENO VALLEY COMMUNITY SERVICES DISTRICT
CITY AS SUCCESSOR AGENCY FOR THE
COMMUNITY REDEVELOPMENT AGENCY OF THE
CITY OF MORENO VALLEY
MORENO VALLEY HOUSING AUTHORITY
MORENO VALLEY PUBLIC FINANCING AUTHORITY
BOARD OF LIBRARY TRUSTEES**

**REGULAR MEETING – 6:00 PM
October 3, 2023**

CALL TO ORDER

The Joint Meeting of the City Council, Community Services District, City as Successor Agency for the Community Redevelopment Agency of the City of Moreno Valley, Moreno Valley Housing Authority, Moreno Valley Public Financing Authority and the Board of Library Trustees was called to order at 6:01 p.m. by Mayor Cabrera in the Council Chamber located at 14177 Frederick Street.

Mayor Cabrera announced that the City Council receives a separate stipend for CSD meetings.

PLEDGE OF ALLEGIANCE

The Pledge of Allegiance was led by Mayor Pro Tem Delgado.

INVOCATION - PASTOR ISRAEL CARLOS OF APOSTOLIC ASSEMBLY

The invocation was given by Pastor Israel Carlos of Apostolic Assembly.

ROLL CALL

Council:	Ulises Cabrera	Mayor
	Ed Delgado	Mayor Pro Tem
	Elena Baca-Santa Cruz	Council Member
	David Marquez	Council Member
	Cheylynda Barnard	Council Member

INTRODUCTIONS

Minutes Acceptance: Minutes of Oct 3, 2023 6:00 PM (CONSENT CALENDAR-CITY COUNCIL)

Staff:	Jane Halstead	Manager of the Office of the Mayor and City Council/City Clerk
	Patty Rodriguez	Senior Deputy City Clerk
	Steven Quintanilla	City Attorney
	Mike Lee	City Manager
	Brian Mohan	Assistant City Manager, Chief Financial Officer, City Treasurer
	Michael Lloyd	Assistant City Manager
	Sean Kelleher	Community Development Director
	Melissa Walker	Public Works Director/City Engineer
	Jeremy Bubnick	Parks and Community Services Director
	Tyson Voss	Lieutenant
	Jesse Park	Fire Chief

PUBLIC COMMENTS ON ANY SUBJECT NOT ON THE AGENDA UNDER THE JURISDICTION OF THE CITY COUNCIL

Seth Cox

- 1. Alcohol & tobacco sales.

David Zeitz

- 1. Pet adoptions.

Roy Bleckert

- 1. Public safety.

Bob Palomarez

- 1. Investigation.

Pete Bleckert

- 1. City history.

Louise Palomarez

- 1. Critical of Mayor Cabrera.

PUBLIC COMMENTS ON ANY SUBJECT ON THE AGENDA UNDER THE JURISDICTION OF THE CITY COUNCIL

JOINT CONSENT CALENDARS (SECTIONS A-E)

Minutes Acceptance: Minutes of Oct 3, 2023 6:00 PM (CONSENT CALENDAR-CITY COUNCIL)

Motion made by Council Member Marquez and seconded by Mayor Pro Tem Delgado to approve the consent calendar.

Motion passed by a vote of 5-0, with Council Member Baca-Santa Cruz, Council Member Marquez, Council Member Barnard, Mayor Pro Tem Delgado, and Mayor Cabrera voting yes.

RESULT:	APPROVED [UNANIMOUS]
MOVER:	David Marquez, Council Member
SECONDER:	Ed Delgado, Mayor Pro Tem
AYES:	Cabrera, Delgado, Marquez, Barnard, Baca-Santa Cruz

A. CONSENT CALENDAR-CITY COUNCIL

- A.1. ORDINANCES - READING BY TITLE ONLY - THE MOTION TO ADOPT AN ORDINANCE LISTED ON THE CONSENT CALENDAR INCLUDES WAIVER OF FULL READING OF THE ORDINANCE.

Recommendation: Waive reading of all Ordinances.

- A.2. City Council - Closed Session - Sep 19, 2023 5:00 PM
- A.3. City Council - Regular Meeting - Sep 19, 2023 6:00 PM
- A.4. PURSUANT TO LANDOWNER PETITIONS, ANNEX CERTAIN PARCELS INTO COMMUNITY FACILITIES DISTRICT NO. 2014-01 (MAINTENANCE SERVICES) - AMENDMENT NOS. 79 and 81 (RESO NO. 2023-64 and RESO NO. 2023-65) (Report of: Financial & Management Services)

Recommendation:

1. Acting as the legislative body of Community Facilities District No. 2014-01 (Maintenance Services), adopt Resolution No. 2023-64, a Resolution of the City Council of the City of Moreno Valley, California, ordering the annexation of territory to City of Moreno Valley Community Facilities District No. 2014-01 (Maintenance Services) and approving the amended map for said District (Amendment No. 79) (D.R. Horton Los Angeles Holding Company, Inc., located on the southwest corner of Alessandro Blvd. and Oliver St.).
2. Acting as the legislative body of Community Facilities District No. 2014-01 (Maintenance Services), adopt Resolution No. 2023-65, a Resolution of the City Council of the City of Moreno Valley, California, ordering the annexation of territory to City of Moreno Valley Community Facilities District No. 2014-01 (Maintenance Services) and approving the amended map for said District (Amendment No. 81) (D.R. Horton Los Angeles Holding Company, Inc., located on the northeast corner of Oliver St. and Brodiaea Ave.).

- A.5. APPROVAL OF SECOND AMEND TO AGREEMENT WITH MORENO VALLEY MALL HOLDING, LLC. FOR LIBRARY SPACE LEASE AT THE MORENO VALLEY MALL (Report of: Parks & Community Services)

Recommendations: That the City Council and CSD:

1. Approve second amendment with Moreno Valley Mall Holding, LLC. (2250 Town Circle Holdings, LLC) for Library Space lease of space #2078 at the Moreno Valley Mall.
2. Authorize Executive Director/City Manager to execute the Second Amendment in the amount of \$137,490.80 and request required Purchase Order(s) in FY 23/24-24/25.
3. Authorize the City Manager to execute any subsequent Amendments to the Agreement within Council approved annual budgeted amounts, including the authority to authorize the associated purchase orders in accordance with the terms of the Agreement, subject to the approval of the City Attorney.

- A.6. PEN21-0136 (TR 38123) – ACCEPT DEVELOPMENT IMPACT FEE (DIF) IMPROVEMENT CREDIT AGREEMENT #D23-003 FOR SKYLAR/WINDSONG RESIDENTIAL DEVELOPMENT LOCATED AT THE NORTHEAST CORNER OF ALESSANDRO BOULEVARD AND LASSELLE STREET. DEVELOPER: D.R. HORTON, LOS ANGELES HOLDING COMPANY, INC. (Report of: Public Works)

Recommendations:

1. Accept and approve the Development Impact Fees Improvement Credit Agreement #D23-003 (DIF Agreement) for PEN21-0136 improvements; and
2. Authorize the City Manager to execute the DIF Agreement.

- A.7. AUTHORIZATION TO AWARD AN AGREEMENT FOR PROFESSIONAL CONSULTANT SERVICES TO IMS INFRASTRUCTURE MANAGEMENT SERVICES FOR THE 2024 PAVEMENT MANAGEMENT SYSTEM UPDATES AND ROADWAY ASSET DATA COLLECTION SERVICES, PROJECT NO. 801 0083 (Report of: Public Works)

Recommendations:

1. Award a Professional Consultant Services Agreement to IMS Infrastructure Management Services, LP to provide updates to the Pavement Management System and perform Roadway Asset Data Collection Services;

2. Authorize the City Manager to execute the Professional Consultant Services Agreement with IMS Infrastructure Management Services, LP, in the amount of \$574,683, funded by the State Gasoline Tax (Fund 2000);
3. Authorize the issuance of a Purchase Order to IMS Infrastructure Management Services, LP in the amount of \$574,683 when the agreement has been signed by all parties; and
4. Authorize the City Manager to execute any subsequent Amendments to the Agreement with IMS Infrastructure Management Services, LP within Council approved annual budgeted amounts, including the authority to authorize the associated purchase orders in accordance with the terms of the Agreement, subject to the approval of the City Attorney.

A.8. **SECOND READING - MUNICIPAL CODE AMENDMENTS TO MODIFY PROVISIONS IN TITLE 8, SECTION 8.21.020 – PERMITS REQUIRED AND SECTION 8.21.160 – EROSION CONTROL (Report of: Public Works)**

Recommendation:

1. Conduct second reading by title only and Adopt Ordinance No. 1001. An Ordinance of the City Council of the City of Moreno Valley, California, thereby amending the City of Moreno Valley Municipal Code Sections 8.21.020 and 8.21.160 related to permits required and erosion control.

A.9. **PEN18-0080 (TR 37462) - APPROVE TRACT MAP 37462 LOCATED ON THE NORTH SIDE OF BRADSHAW CIRCLE EAST OF MORENO BEACH DRIVE. OWNER: HAKAN BUVAN (Report of: Public Works)**

Recommendations:

1. Approve Tract Map 37462; and
2. Authorize the City Clerk to sign the map and transmit said map to the County Recorder's Office for recordation.

B. CONSENT CALENDAR-COMMUNITY SERVICES DISTRICT

B.1. **ORDINANCES - READING BY TITLE ONLY - THE MOTION TO ADOPT AN ORDINANCE LISTED ON THE CONSENT CALENDAR INCLUDES WAIVER OF FULL READING OF THE ORDINANCE.**

Recommendation: Waive reading of all Ordinances.

- B.2. MINUTES - CITY COUNCIL - CLOSED SESSION - SEPTEMBER 19, 2023
5:00 PM.

Recommendation:

1: Approve as submitted.

- B.3. MINUTES - CITY COUNCIL - REGULAR MEETING - SEPTEMBER 19, 2023
6:00 PM.

Recommendation:

1: Approve as submitted.

- B.4. PURSUANT TO LANDOWNER PETITIONS, ANNEX CERTAIN PARCELS INTO COMMUNITY FACILITIES DISTRICT NO. 2021-01 (PARKS MAINTENANCE) - AMENDMENT NOS. 60, 79, 104, 106, 109, and 114-116 (RESO. NOS. CSD 2023-76 to CSD 2023-83) (Report of: Financial & Management Services)

Recommendation:

1. Adopt Resolution No. CSD 2023-76, a Resolution of the Board for the Moreno Valley Community Services District of the City of Moreno Valley, California, ordering the annexation of territory to City of Moreno Valley Community Facilities District No. 2021-01 (Parks Maintenance) and approving the amended map for said District (Amendment No. 60) (SPSSM INV VI, located at 12054 Graham St.).
2. Adopt Resolution No. CSD 2023-77, a Resolution of the Board for the Moreno Valley Community Services District of the City of Moreno Valley, California, ordering the annexation of territory to City of Moreno Valley Community Facilities District No. 2021-01 (Parks Maintenance) and approving the amended map for said District (Amendment No. 79) (D.R. Horton Los Angeles Holding Company, Inc., located on the southwest corner of Alessandro Blvd. and Oliver St.).
3. Adopt Resolution No. CSD 2023-78, a Resolution of the Board for the Moreno Valley Community Services District of the City of Moreno Valley, California, ordering the annexation of territory to City of Moreno Valley Community Facilities District No. 2021-01 (Parks Maintenance) and approving the amended map for said District (Amendment No. 104) (Chau Van Nguyen, located at 24168 Mt. Russell).
4. Adopt Resolution No. CSD 2023-79, a Resolution of the Board for the Moreno Valley Community Services District of the City of Moreno

Valley, California, ordering the annexation of territory to City of Moreno Valley Community Facilities District No. 2021-01 (Parks Maintenance) and approving the amended map for said District (Amendment No. 106) (D.R. Horton Los Angeles Holding Company, Inc., located on the northeast corner of Oliver St. and Brodiaea Ave.).

5. Adopt Resolution No. CSD 2023-80, a Resolution of the Board for the Moreno Valley Community Services District of the City of Moreno Valley, California, ordering the annexation of territory to City of Moreno Valley Community Facilities District No. 2021-01 (Parks Maintenance) and approving the amended map for said District (Amendment No. 109) (Emerita Bidgood Cruz and Christian Roman Hassard Gastelum, located at 10953 Mendoza Rd.).
6. Adopt Resolution No. CSD 2023-81, a Resolution of the Board for the Moreno Valley Community Services District of the City of Moreno Valley, California, ordering the annexation of territory to City of Moreno Valley Community Facilities District No. 2021-01 (Parks Maintenance) and approving the amended map for said District (Amendment No. 114) (Daniel and Verence Vences, located at 25404 Sand Creek Trl.).
7. Adopt Resolution No. CSD 2023-82, a Resolution of the Board for the Moreno Valley Community Services District of the City of Moreno Valley, California, ordering the annexation of territory to City of Moreno Valley Community Facilities District No. 2021-01 (Parks Maintenance) and approving the amended map for said District (Amendment No. 115) (Arturo Bravo Jr. and Antonio Rangel, and Mayra Isabel Esparza Soria located at 22890 Scotia Ln.).
8. Adopt Resolution No. CSD 2023-83, a Resolution of the Board for the Moreno Valley Community Services District of the City of Moreno Valley, California, ordering the annexation of territory to City of Moreno Valley Community Facilities District No. 2021-01 (Parks Maintenance) and approving the amended map for said District (Amendment No. 116) (Jessida Annette Macias, located at 14701 Unity Ct.).

C. CONSENT CALENDAR - HOUSING AUTHORITY

- C.1. ORDINANCES - READING BY TITLE ONLY - THE MOTION TO ADOPT AN ORDINANCE LISTED ON THE CONSENT CALENDAR INCLUDES WAIVER OF FULL READING OF THE ORDINANCE.

Recommendation: Waive reading of all Ordinances.

- C.2. MINUTES - CITY COUNCIL - CLOSED SESSION - SEPTEMBER 19, 2023
5:00 PM.

Recommendation:

- 1: Approve as submitted.

- C.3. MINUTES - CITY COUNCIL - REGULAR MEETING - SEPTEMBER 19,
2023 6:00 PM.

Recommendation:

- 1: Approve as submitted.

D. CONSENT CALENDAR - BOARD OF LIBRARY TRUSTEES

- D.1. ORDINANCES - READING BY TITLE ONLY - THE MOTION TO ADOPT AN
ORDINANCE LISTED ON THE CONSENT CALENDAR INCLUDES WAIVER
OF FULL READING OF THE ORDINANCE.

Recommendation: Waive reading of all Ordinances.

- D.2. MINUTES - CITY COUNCIL - CLOSED SESSION - SEPTEMBER 19, 2023
5:00 PM.

Recommendation:

- 1: Approve as submitted.

- D.3. MINUTES - CITY COUNCIL - REGULAR MEETING - SEPTEMBER 19,
2023 6:00 PM.

Recommendation:

- 1: Approve as submitted.

E. CONSENT CALENDAR - PUBLIC FINANCING AUTHORITY

- E.1. ORDINANCES - READING BY TITLE ONLY - THE MOTION TO ADOPT AN
ORDINANCE LISTED ON THE CONSENT CALENDAR INCLUDES WAIVER
OF FULL READING OF THE ORDINANCE.

Recommendation: Waive reading of all Ordinances.

- E.2. MINUTES - CITY COUNCIL - CLOSED SESSION - SEPTEMBER 19, 2023
5:00 PM.

Recommendation:

1: Approve as submitted.

E.3. MINUTES - CITY COUNCIL - REGULAR MEETING - SEPTEMBER 19, 2023
6:00 PM.

Recommendation:

1: Approve as submitted.

F. PUBLIC HEARINGS

F.1. ACCEPT THE U.S. DEPARTMENT OF HOUSING AND URBAN DEVELOPMENT (HUD) HOME AMERICAN RESCUE PLAN (HOME-ARP) REVISED PROPOSED ALLOCATION PLAN (Report of: City Manager)

1. Adopt Resolution No. 2023-66 to accept the U.S. Department of Housing and Urban Development (HUD) HOME American Rescue Plan (HOME-ARP) funds and revised allocation plan, and
2. Designate the City Manager, City Attorney and Chief Financial Officer as authorized signatory to execute HOME-ARP documents on behalf of the City of Moreno Valley as outlined on the revised allocation plan.

Staff report provided by Assistant City Manager Brian Mohan.

With the staff report concluded, Mayor Cabrera opened the floor for Council questions of staff.

Council Member Marquez and Mayor Cabrera asked questions of staff.

Assistant City Manager Brian Mohan answered Council Member Marquez's and Mayor Cabrera's inquiries.

With the conclusion of Council questions, Mayor Cabrera called for public comments to be heard.

With no public comments, Mayor Cabrera entertained a motion.

Motion made by Council Member Marquez and seconded by Mayor Pro Tem Delgado to accept the U.S. Department of Housing and Urban Development (HUD) Home American Rescue Plan (HOME-ARP) revised proposed allocation plan.

Motion passed by a vote of 5-0, with Council Member Baca-Santa Cruz, Council Member Marquez, Council Member Barnard, Mayor Pro Tem Delgado, and Mayor Cabrera voting yes.

RESULT: APPROVED [UNANIMOUS]
MOVER: David Marquez, Council Member
SECONDER: Ed Delgado, Mayor Pro Tem
AYES: Cabrera, Delgado, Marquez, Barnard, Baca-Santa Cruz

- F.2. PUBLIC HEARING, SECOND READING, AND ADOPTION OF COUNTY ORDINANCES NUMBERS 523 AND 640 REGARDING CONTROL OF VECTORS AND ESTABLISHING ENVIRONMENTAL HEALTH SERVICES FEES AND PENALTIES (ORD. NO. 1000) (Report of: Community Development)

Recommendations: That the City Council:

1. **CONDUCT** a Public Hearing to receive public input on the proposed Ordinance adopting Riverside County Ordinances numbers 523 and 640 regarding control of vectors and establishing environmental health services fees and penalties.
2. **CONDUCT** a second reading by title only and adopt Ordinance No. 1000, amending Title 6 of the City of Moreno Valley Municipal Code, adding Chapter 6.16, adopting by reference Riverside County Ordinance No. 523; and amending Title 3 of the City of Moreno Valley Municipal Code, adding Chapter 3.52, adopting by reference Riverside County Ordinance No. 640.

Staff report provided by Community Development Director Sean Kelleher.

At the conclusion of the staff report, Mayor Cabrera called for Council questions of staff.

With no Council questions of staff, Mayor Cabrera called for public comments to be heard.

With no public comments on this item, Mayor Cabrera entertained a motion from Council.

Motion made by Mayor Pro Tem Delgado and seconded by Council Member Baca-Santa Cruz to approve the second reading and adoption of County Ordinances numbers 523 and 640 regarding control of vectors and establishing environmental health service fees and penalties (ORD. NO. 1000).

Motion passed by a vote of 5-0, with Council Member Baca-Santa Cruz, Council Member Marquez, Council Member Barnard, Mayor Pro Tem Delgado, and Mayor Cabrera voting yes.

RESULT: APPROVED [UNANIMOUS]
MOVER: Ed Delgado, Mayor Pro Tem
SECONDER: Elena Baca-Santa Cruz, Council Member
AYES: Cabrera, Delgado, Marquez, Barnard, Baca-Santa Cruz

G. ITEMS REMOVED FROM CONSENT CALENDARS FOR DISCUSSION OR SEPARATE ACTION

None.

H. GENERAL BUSINESS

- H.1. ORDINANCE ADDING CHAPTER 2.66 "ELECTRONIC FILING OF CAMPAIGN DISCLOSURE STATEMENTS," RELATING TO ELECTRONIC FILING OF FAIR POLITICAL PRACTICES COMMISSION STATEMENTS (Report of: City Clerk)

Recommendation:

1. That the City Council introduce by title only and waive further reading of an Ordinance adding Chapter 2.66, "Electronic Filing of Campaign Disclosure Statement" to the Moreno Valley Municipal Code.

Staff report provided by City Clerk Jane Halstead.

At the conclusion of the staff report, Mayor Cabrera called for Council questions of staff.

Council Member Baca-Santa Cruz asked questions of staff.

City Clerk Jane Halstead and City Attorney Steven Quintanilla responded to Council Member Baca-Santa Cruz's inquiries.

With the conclusion of Council questions of staff, Mayor Cabrera called for public comments to be heard.

Louise Palomarez

1. Critical of Mayor Cabrera and Council Member Marquez.

Public comments were heard.

With the conclusion of public comments, Mayor Cabrera called for Council deliberation.

After Council deliberated, Mayor Cabrera entertained a motion.

Motion made by Council Member Marquez and seconded by

Council Member Barnard to approve the 1st reading of Ordinance 1002 and schedule the 2nd reading of Ordinance 1002 to the October 17, 2023 City Council meeting.

Motion passed by a vote of 5-0, with Council Member Baca-Santa Cruz, Council Member Marquez, Council Member Barnard, Mayor Pro Tem Delgado, and Mayor Cabrera voting yes.

RESULT:	APPROVED [UNANIMOUS]
MOVER:	David Marquez, Council Member
SECONDER:	Cheylynda Barnard, Council Member
AYES:	Cabrera, Delgado, Marquez, Barnard, Baca-Santa Cruz

H.2. DISCUSSION TO EXPLORE OPTIONS ON THE CREATION OF THE THIRD SATELLITE LIBRARY (Report of: City Manager)

Recommendations:

1. Authorize the Assistant City Manager/CFO/Treasurer to locate a suitable third satellite library site, negotiate and execute a lease agreement including any tenant improvements that may be needed to the suitable site before occupancy, revise the current contract with Library Systems & Services (our current library program consultant) to include the programming for the new satellite library, and any other items deemed necessary to get the new satellite library operational; or
2. Provide alternate direction to the Assistant City Manager.

Assistant City Manager Brian Mohan provided the staff report.

With the conclusion of the staff, Mayor Cabrera called for Council questions of staff.

Council Member Baca-Santa Cruz asked questions of staff.

Assistant City Manager Brian Mohan answered all of Council Member Baca-Santa Cruz's inquiries.

With the conclusion of Council questions of staff, Mayor Cabrera called for public comments to be heard.

Alicia Berridge

1. Supports project.

William Evans

1. Supports project.

Bob Palomarez

1. Supports project.

Louise Palomarez

1. Concerns.

Public comments were heard.

With the conclusion of public comments, Mayor Cabrera called for Council deliberation.

After Council deliberated, Mayor Cabrera entertained a motion.

Motion made by Mayor Pro Tem Delgado and seconded by Council Member Marquez to direct City staff to look at locations within District 2 for the creation of a third Satellite Library.

Motion passed by a vote of 5-0, with Council Member Baca-Santa Cruz, Council Member Marquez, Council Member Barnard, Mayor Pro Tem Delgado, and Mayor Cabrera voting yes.

RESULT:	APPROVED [UNANIMOUS]
MOVER:	Ed Delgado, Mayor Pro Tem
SECONDER:	David Marquez, Council Member
AYES:	Cabrera, Delgado, Marquez, Barnard, Baca-Santa Cruz

I.REPORTS

I.1. CITY COUNCIL REPORTS

March Joint Powers Commission (JPC)

Mayor Pro Tem Delgado reported the following:

The Commission received an Economic Impact Analysis of current JPA development, as well as projections of the economic benefits at full build-out, and the Commission adopted an Employee Retention Policy to retain JPA employees through the sunseting process.

Riverside County Habitat Conservation Agency (RCHCA)

None.

Riverside County Transportation Commission (RCTC)

None.

Riverside Transit Agency (RTA)

Council Member Marquez reported the following:

The Board had extensive discussion on the proposed four (4) custom shelters in Mead Valley and denied the recommendation of installation. Furthermore, the Board instructed RTA staff to work with County of Riverside and create a new plan.

The Board authorized staff to award an agreement to Amtech Elevator Services to modernize the elevator at the Corona Transit Center.

Western Riverside Council of Governments (WRCOG)

None.

Western Riverside County Regional Conservation Authority (RCA)

Council Member Marquez reported the following:

Items covered at the RCA Board of Directors meeting on October 2, 2023, included a status report on acquisitions made by RCA. As of July 31, 2023, 31 parcels have been acquired, adding approximately 1,000 acres to the reserve.

School District/City Joint Task Force

None.

I.2. EMPLOYEE ASSOCIATION REPORTS

None.

I.3. CITY MANAGER'S REPORT

1. City Awards

CLOSING COMMENTS AND/OR REPORTS OF THE CITY COUNCIL, COMMUNITY SERVICES DISTRICT, CITY AS SUCCESSOR AGENCY FOR THE COMMUNITY REDEVELOPMENT AGENCY, HOUSING AUTHORITY, PUBLIC FINANCING AUTHORITY, AND THE BOARD OF LIBRARY TRUSTEES.

Council Member Baca-Santa Cruz

- 1. League of California Cities.
- 2. Helen Putnam Award.
- 3. Women’s Conference.

Council Member Marquez

- 1. Praise City Staff.
- 2. Veteran Affairs Job Fair.

Council Member Barnard

No comments.

Mayor Pro Tem Delgado

- 1. Employee appreciation.
- 2. Coffee Event.
- 3. Retirement.

Mayor Cabrera

- 1. League of California Cities.
- 2. Latino Caucus.
- 3. Community events.

Motion made by Mayor Cabrera and seconded by Council Member Baca-Santa Cruz to table an item that was scheduled for the next Study Session to discuss the possibility of finding or building a parking lot that would allow homeless families to sleep in their car.

Motion passed by a vote of 2-0, with Council Member Baca-Santa Cruz and Mayor Cabrera voting yes.

RESULT: APPROVED [UNANIMOUS]
MOVER: Ulises Cabrera, Mayor
SECONDER: Elena Baca-Santa Cruz, Council Member

Minutes Acceptance: Minutes of Oct 3, 2023 6:00 PM (CONSENT CALENDAR-CITY COUNCIL)

ADJOURNMENT

There being no further business to come before the City Council, Mayor Cabrera adjourned the meeting at 7:46PM.

PUBLIC INSPECTION

The contents of the agenda packet are available for public inspection on the City’s website at www.moval.org and in the City Clerk’s office at 14177 Frederick Street during normal business hours.

Any written information related to an open session agenda item that is known by the City to have been distributed to all or a majority of the City Council less than 72 hours prior to this meeting will be made available for public inspection on the City’s website at www.moval.org and in the City Clerk’s office at 14177 Frederick Street during normal business hours.

Submitted by:

Jane Halstead, CMC
City Clerk
Secretary, Moreno Valley Community Services District
Secretary, City as Successor Agency for the Community
Redevelopment Agency of the City of Moreno Valley
Secretary, Moreno Valley Housing Authority
Secretary, Board of Library Trustees
Secretary, Public Financing Authority

Approved by:

Ulises Cabrera
Mayor
City of Moreno Valley
President, Moreno Valley Community Services District
Chairperson, City as Successor Agency for the Community
Redevelopment Agency of the City of Moreno Valley
Chairperson, Moreno Valley Housing Authority
Chairperson, Board of Library Trustees
Chairperson, Public Financing Authority

Minutes Acceptance: Minutes of Oct 3, 2023 6:00 PM (CONSENT CALENDAR-CITY COUNCIL)



Report to City Council

TO: Mayor and City Council

FROM: Jane Halstead, CMC, City Clerk

AGENDA DATE: October 17, 2023

TITLE: COUNCIL DISCRETIONARY EXPENDITURE REPORTS FOR FISCAL YEAR 2023/2024 FROM JULY 1, 2023 THROUGH AUGUST 31, 2023.

RECOMMENDED ACTION

Recommendation:

1. Receive and file the Fiscal Year 2023/2024 Council Discretionary Expenditure Report for July 1, 2023 through August 31, 2023.

SUMMARY

This staff report is prepared at the request of the City Council to provide transparency with respect to the expenditure of City funds from City Council Discretionary Expenditure Accounts. These reports are for each Council Member's year to date expenditures for Fiscal Year 2023/2024, for July 1, 2023 through August 31, 2023. Each Council District receives an annual budget allocation of \$3,000 and the Mayor receives an annual budget allocation of \$6,000.

With the adoption of the current fiscal year budget and pursuant to Resolution No. 2023-24, unused monies from Fiscal Year 2022/2023 will be carried over to the current Fiscal Year as approved by the City Manager.

The expenditure reports are included routinely in the City Council agenda as an additional means of distributing reports on activities to the Council and public. The reports are to be posted to the City's website following Council approval. The monthly reports provide unaudited information and are reconciled to the City's general ledger. Following the end of the Fiscal Year, the financial information shall be reviewed as part of the City's independent financial audit.

NOTIFICATION

Posting of the agenda as required by the Brown Act.

PREPARATION OF STAFF REPORT

Prepared By:
Jasmin Rivera
Management Assistant

Department Head Approval:
Jane Halstead
City Clerk

CITY COUNCIL GOALS

None

CITY COUNCIL STRATEGIC PRIORITIES

- 1. Economic Development
- 2. Public Safety
- 3. Library
- 4. Infrastructure
- 5. Beautification, Community Engagement, and Quality of Life
- 6. Youth Programs

ATTACHMENTS

To view large attachments, please click your “bookmarks”



on the left hand side of this document for the necessary attachment.

- 1. FY 23-24 Expenditure Report Sheet

APPROVALS

Budget Officer Approval	<u>✓ Approved</u>	10/10/23 8:49 AM
City Attorney Approval	<u>✓ Approved</u>	
City Manager Approval	<u>✓ Approved</u>	10/10/23 8:52 AM



MAYOR ULISES CABRERA

Fiscal Year 2023/2024 Council Discretionary Expenditures
 Accounts: 1010-10-01-10015-620130 Mayor Discretionary
 1010-10-01-10015-620131 Mayor Discretionary - Carryover
 July 1, 2023 – August 31, 2023

Date	Amount	Description
7/25/2023	\$ 1,000.00	Kids Youth Mentorship Services Inc. Back-to-School Backpack Giveaway Event
7/31/2023	\$ 102.59	Senior Center Community Engagement Consumables
7/31/2023	\$ 75.00	We Walk by Faith Not by Sight Event
8/25/2023	\$ 300.00	StreetBeat Ave. Records and Moreno Valley Mall Christmas Toy Drive

\$ 1,477.59 TOTAL Council Discretionary Expenditures for FY 23/24

\$ 6,000.00 FY 23/24 Adopted Budget Amount

\$ 6,000.00 FY 23/24 Amended Budget Amount

\$ 4,522.41 FY 23/24 Budget Amount Remaining

Source: Unaudited financial data from the City's accounting records.
 Updated as of: 10/9/2023



MAYOR PRO TEM EDWARD A. DELGADO

Fiscal Year 2023/2024 Council Discretionary Expenditures
 Accounts: 1010-10-01-10012-620112 District 2 Discretionary
 1010-10-01-10012-620117 District 2 Discretionary - Carryover
 July 1, 2023 – August 31, 2023

Date	Amount	Description
		No expenditures to report for July 2023
		No expenditures to report for August 2023

\$	0.00	TOTAL Council Discretionary Expenditures for FY 23/24
\$	3,000.00	FY 23/24 Adopted Budget Amount
\$	3,000.00	FY 23/24 Amended Budget Amount
\$	3,000.00	FY 23/24 Budget Amount Remaining

Source: Unaudited financial data from the City's accounting records.
 Updated as of: 10/9/2023



COUNCIL DISTRICT 1 ELENA BACA-SANTA CRUZ

Fiscal Year 2023/2024 Council Discretionary Expenditures
Accounts: 1010-10-01-10011-620111 District 1 Discretionary
1010-10-01-10011-620116 District 1 Discretionary - Carryover
July 1, 2023 – August 31, 2023

Date	Amount	Description
No expenditures to report for July 2023		
8/04/2023	\$ 250.00	Diamond Girls Softball Association Team Contribution: Queen Kobras
8/15/2023	\$ 300.00	Diamond Girls Softball Association Team Contribution: Cyclones

\$	<u>550.00</u>	TOTAL Council Discretionary Expenditures for FY 23/24
\$	<u>3,000.00</u>	FY 23/24 Adopted Budget Amount
\$	<u>3,000.00</u>	FY 23/24 Amended Budget Amount
\$	2,450.00	FY 23/24 Budget Amount Remaining

Source: Unaudited financial data from the City's accounting records.
Updated as of: 10/9/2023



COUNCIL DISTRICT 3 DAVID MARQUEZ

Fiscal Year 2023/2024 Council Discretionary Expenditures
 Accounts: 1010-10-01-10013-620113 District 3 Discretionary
 1010-10-01-10013-620118 District 3 Discretionary - Carryover
 July 1, 2023 – August 31, 2023

Date	Amount	Description
No expenditures to report for July 2023		
8/04/2023	\$	500.00 Diamond Girls Softball Association Team Contribution: Ice Queens

\$	500.00	TOTAL Council Discretionary Expenditures for FY 23/24
\$	<u>3,000.00</u>	FY 23/24 Adopted Budget Amount
\$	<u>3,000.00</u>	FY 23/24 Amended Budget Amount
\$	2,500.00	FY 23/24 Budget Amount Remaining

Source: Unaudited financial data from the City's accounting records.
 Updated as of: 10/9/2023



COUNCIL DISTRICT 4 CHEYLYNDA BARNARD

Fiscal Year 2023/2024 Council Discretionary Expenditures
 Accounts: 1010-10-01-10014-620114 District 4 Discretionary
 1010-10-01-10014-620119 District 4 Discretionary - Carryover
 July 1, 2023 – August 31, 2023

Date	Amount	Description
7/31/2023	\$ 100.00	Rancho Verde High School Cheer
7/31/2023	\$ 134.86	District 4 Community Engagement Consumables
8/15/2023	\$ 200.00	Diamond Girls Softball Association Team Contribution: Ice Queens
8/15/2023	\$ 13.27	District 4 Community Engagement Refreshments
8/17/2023	\$ 23.70	District 4 Community Engagement Consumables
8/18/2023	\$ 200.00	Diamond Girls Softball Association Team Contribution: Cyclones

<u>\$ 671.83</u>	TOTAL Council Discretionary Expenditures for FY 23/24
<u>\$ 3,000.00</u>	FY 23/24 Adopted Budget Amount
<u>\$ 3,000.00</u>	FY 23/24 Amended Budget Amount
\$ 2,328.17	FY 23/24 Budget Amount Remaining

Source: Unaudited financial data from the City's accounting records.
 Updated as of: 10/9/2023

Attachment: FY 23-24 Expenditure Report Sheet (6115 : COUNCIL DISCRETIONARY EXPENDITURE REPORTS FOR FISCAL YEAR 2023/2024)



Report to City Council

TO: Mayor and City Council

FROM: Jane Halstead, CMC, City Clerk

AGENDA DATE: October 17, 2023

TITLE: COUNCIL TRAINING & TRAVEL EXPENDITURE REPORTS FOR FISCAL YEAR 2023-2024

RECOMMENDED ACTION

Recommendation:

1. Receive and file the Training & Travel Authorization Forms for the month of September 2023.

SUMMARY

This staff report is prepared at the request of the City Council to provide transparency with respect to the expenditure of City funds used for City Council Training and Travel. Each Council District receives an annual budget allocation of \$4,000 and the Mayor receives an annual budget allocation of \$12,000.

On September 5, 2023, the City Council approved the revision of policy #3.06; to incorporate additional transparency requirements for the reporting of the travel and training forms.

The training and travel forms provide unaudited information and are reconciled to the City's general ledger. Following the end of the Fiscal Year, the financial information shall be reviewed as part of the City's independent financial audit.

FISCAL IMPACT

No Fiscal Impact as all funds are budgeted within the Fiscal Year 2023/2024 annual budget.

PREPARATION OF STAFF REPORT

Prepared By:
Name Jasmin Rivera
Title Executive Assistant to the Mayor and Council Office

Department Head Approval:
Name Jane Halstead
Title City Clerk

Concurred By:
Name
Title

CITY COUNCIL GOALS

None

CITY COUNCIL STRATEGIC PRIORITIES

1. Economic Development
2. Public Safety
3. Library
4. Infrastructure
5. Beautification, Community Engagement, and Quality of Life
6. Youth Programs

ATTACHMENTS

To view large attachments, please click your “bookmarks”  on the left hand side of this document for the necessary attachment.

1. Ulises Cabrera - Travel Authorization & Expense Report - League of Cal Cities_Redacted
2. Elena Baca-Santa Cruz - Travel Authorization & Expense Report - League of Cal Cities_Redacted
3. David Marquez - Travel Authorization & Expense Report - League of Cal Cities

APPROVALS

Budget Officer Approval	<u>✓ Approved</u>	10/12/23 10:27 AM
City Attorney Approval	<u>✓ Approved</u>	
City Manager Approval	<u>✓ Approved</u>	10/12/23 2:34 PM



Travel Authorization & Expense Reporting Form

Instructions: **Prior to any** travel, complete **Part I** of this form to have travel and anticipated expenses approved. Submit a copy of this approved form with each payment expense submitted. **Upon returning** from travel, complete **Part II** of this form to confirm total expenses including any approved adjustment. Submit form to Accounts Payable within **15 days** of the travel end date. **Always use the most up-to-date Travel Form located on the City's Intranet.**

Part I - Travel Authorization		<u>Employee Signature</u> <i>[Signature]</i>		<u>Immediate Supervisor Signature</u>	
Name: Ulises Cabrera		Purpose of Trip: League of California Cities 2023 Annual Conference			
Job Title: Mayor		Destination: 1401 K St, Sacramento, CA 95814			Out of State <input type="checkbox"/>
Division: City Council		Enter below the departing date and time then the return date and time. Per diem travel days will automatically be calculated.			
GL Org Set(s) 1010100110015	% Split 100%	Split Total Equals 100%	Departure Date & Time: 9/19/23 11:55 AM	Example: 1/2/18 7:30 A	
			Return Date & Time: 9/21/23 2:20 PM	Example: 1/2/18 5:30 P	
Expense Type	Account #	Description of Expenses		Amount	CAL-Car <input checked="" type="checkbox"/> If Y
Registration:	(620510)	League of California Cities Conference Registration		\$650.00	<input checked="" type="checkbox"/>
Lodging :	(620510)	DoubleTree Hilton Hotel		\$364.00 <i>\$409.94</i>	
Mileage:	(620510)	Miles: X	Rate:		<input type="checkbox"/>
Airfare:	(620510)	Southwest Airlines ONT--> SMF SMF-->ONT		\$420.96	<input type="checkbox"/>
*Per Diem:	(620510)	Sacramento, CA		\$69	Check box to decline Per Diem, w hereby actual receipts must be submitted (limits apply).
Total Travel Days (Enter # of Days) >>>			3		
<i>*To receive per diem, travel must include an overnight stay. Per diem on first and last day are to be calculated at 75% of daily per diem rate.</i>				Total Per Diem:	\$146.63
Misc. Other:	(620510)				<input type="checkbox"/>
Business Meals:	(620510)				<input type="checkbox"/>
Division Manager Approval	Date	Total Anticipated Expenses:		\$1,571.59 <i>\$1,627.53</i>	
X	X	City Manager Approval (as required)		Date	
Department Head Approval	Date				
X <i>[Signature]</i>	X <i>8/10/23</i>				X

Part II - Expense Reporting		<i>(Please check the appropriate box below and provide details)</i>			
<input checked="" type="radio"/> No adjustments are necessary. Anticipated expenses match actual expenses incurred. <input type="radio"/> Advance payments exceeded the actual expenses incurred. Attached is my receipt as evidence of reimbursement to the City. (Explain below, use negative numbers) <input type="radio"/> Actual expenses exceeded the anticipated original request. Additional funds are required as listed below.					
Expense Details		Expenditure Code		Amount	CAL-Card
					<input type="checkbox"/>
					<input type="checkbox"/>
Post-Trip I certify that this document is a true and accurate record of travel expenses for official City business.	Employee Signature: X <i>[Signature]</i>	GL Org Set 1010100110015		\$1,571.59 <i>\$1,627.53</i>	
	Date:	Ext.	Split Totals:		
Division Manager Approval	Date	Final Total Expenses:		\$1,627.53	
X	X	City Manager Approval (as required)		Date	
Department Head Approval	Date				
X <i>[Signature]</i>	X <i>10/11/23</i>				X

Invoice



Invoice Date
7/6/2023

Bill To:
Sonia Gomez
14177 Frederick St
Moreno Valley,CA 92553-9014

Ship To:
Sonia Gomez
14177 Frederick St
Moreno Valley,CA 92553-9014
US

Invoice #	Customer #	Shipping Method	Purchase Order			
INV-04547-J3N1W4	73405					
Description	Qty	Unit Price	Discount	Tax	Amount	
Early Bird Full Conference - Member City - Cabrera, Ulises	1.00	\$650.00	\$0.00	\$0.00	\$650.00	
Visa - Authorized - Captured: 48	1.00	\$0.00	\$0.00	\$0.00	\$650.00	
Sub Total by US Dollar:					\$650.00	
Payments:					\$650.00	
Balance:					\$0.00	

Attachment: Ulises Cabrera - Travel Authorization & Expense Report - League of Cal Cities_Redacted (6418 : COUNCIL TRAINING & TRAVEL



LEAGUE OF
CALIFORNIA
CITIES

125 YEARS
1898-2023

ANNUAL Conference and Expo

Sept. 20-22, 2023
Sacramento, CA

Attachment: Ulises Cabrera - Travel Authorization & Expense Report - League of Cal Cities_Redacted (6418 : COUNCIL TRAINING & TRAVEL



LEAGUE OF CALIFORNIA CITIES

MISSION

To expand and protect local control for cities through education and advocacy to enhance the quality of life for all Californians.

VISION

To be recognized and respected as the leading advocate for the common interests of California's cities.

WE BELIEVE

- ◆ Local self-governance is the cornerstone of democracy.
- ◆ Our strength lies in the unity of our diverse communities of interest.
- ◆ In the involvement of all stakeholders in establishing goals and in solving problems.
- ◆ In conducting the business of government with transparency, openness, respect, and civility.
- ◆ The spirit of honest public service is what builds communities.
- ◆ Open decision-making that is of the highest ethical standards honors the public trust.
- ◆ Cities are vital to the strength of the California economy.
- ◆ The vitality of cities is dependent upon their fiscal stability and local autonomy.
- ◆ The active participation of all city officials increases Cal Cities' effectiveness.
- ◆ Partnerships and collaborations are essential elements of focused advocacy and lobbying.
- ◆ Ethical and well-informed city officials are essential for responsive, visionary leadership, and effective and efficient city operations.



DOUBLETREE HOTEL SACRAMENTO
 2001 POINT WEST WAY
 SACRAMENTO, CA 95815
 United States of America
 TELEPHONE 916-929-8855 • FAX 916-929-4913
 Reservations
 www.doubletree.com or 1-800-222-TREE

A.5.a

CABRERA, ULISES



Room No: 3301/NKRQ
 Arrival Date: 9/19/2023 2:03:00 PM
 Departure Date: 9/21/2023 9:27:00 AM
 Adult/Child: 1/0
 Cashier ID: AURIBEVARGAS
 Room Rate: 177.00
 AL:
 HH #
 VAT #
 Folio No/Che 1996830 B

Confirmation Number: 93824881

DOUBLETREE HOTEL SACRAMENTO 10/9/2023 1:06:00 PM

DATE	REF NO	DESCRIPTION	CHARGES
9/19/2023	7227917	GUEST ROOM	\$177.00
9/19/2023	7227917	OCCUPANCY TAX	\$21.24
9/19/2023	7227917	CITY TOURISM ASSESSMENT	\$4.43
9/19/2023	7227917	CITY INFRASTRUCTURE ASMT	\$1.77
9/19/2023	7227917	CA TOURISM ASSESSMENT	\$0.53
9/20/2023	7228277	GUEST ROOM	\$177.00
9/20/2023	7228277	OCCUPANCY TAX	\$21.24
9/20/2023	7228277	CITY TOURISM ASSESSMENT	\$4.43
9/20/2023	7228277	CITY INFRASTRUCTURE ASMT	\$1.77
9/20/2023	7228277	CA TOURISM ASSESSMENT	\$0.53
9/21/2023	7228464	VS *1322	(\$409.94)
BALANCE			\$0.00

FOLLOW US ON FACEBOOK AND TWITTER!

CREDIT CARD DETAIL

APPR CODE	034222	MERCHANT ID	67057170011
CARD NUMBER	VS *1322	EXP DATE	11/23
TRANSACTION ID	7228464	TRANS TYPE	Sale

Attachment: Ulises Cabrera - Travel Authorization & Expense Report - League of Cal Cities_Redacted (6418 : COUNCIL TRAINING & TRAVEL

Sonia Gomez

From: Southwest Airlines <southwestairlines@ifly.southwest.com>
Sent: Thursday, September 14, 2023 2:48 PM
To: City Clerk Staff_DG
Subject: Ulises Cabrera's 09/19 Sacramento trip (2QV9D5): Your change is confirmed.

Warning: External Email – Watch for Email Red Flags!

Here's your updated itinerary and trip receipt.
[View our mobile site](#) | [View in browser](#)



[Manage Flight](#) | [Flight Status](#) | [My Account](#)



Hi Ulises,

We've confirmed the change to your trip. Below you'll find your updated itinerary, important travel information, and trip receipt. See you onboard soon!

SEPTEMBER 19 - SEPTEMBER 21

ONT ✈ SMF

Ontario to Sacramento

Confirmation # **2QV9D5**

Confirmation date: 09/14/2023

PASSENGER **Ulises Cabrera**
RAPID REWARDS # [REDACTED]
TICKET # 5262201843242
EST. POINTS EARNED 3,522

Rapid Rewards® points are only estimations.

Your itinerary

Flight 1: Tuesday, 09/19/2023 Est. Travel Time: 1h 20m [Wanna Get Away Plus™](#)

	DEPARTS		ARRIVES
FLIGHT # 2222	ONT 11:55AM	✈	SMF 01:15PM
	Ontario		Sacramento

Flight 2: Thursday, 09/21/2023 Est. Travel Time: 1h 20m [Anytime](#)

FLIGHT # 3621	DEPARTS		ARRIVES
	SMF 01:00PM Sacramento		ONT 02:20PM Ontario



Payment information

Total cost		Payment	
Air - 2QV9D5		Visa ending in 1322	
Base Fare	\$ 363.87	Date: September 14, 2023	
U.S. Transportation Tax	\$ 27.29	Payment Amount: \$156.00	
U.S. 9/11 Security Fee	\$ 11.20	Credit from ticket: #5262478233594 to #5262201843242	
U.S. Passenger Facility Chg	\$ 9.00	Date: July 12, 2023	
U.S. Flight Segment Tax	\$ 9.60		
Total	\$ 420.96		

Fare rules: If you decide to make a change to your current itinerary it may result in a fare increase.

Your ticket number: 5262201843242

All your perks, all in one place. (Plus a few reminders.)

-  **Wanna Get Away Plus™ fare:** Your two bags fly free® and no change or cancel fees. Plus same-day flight changes, 8X Rapid Rewards® points, and a Transferable Flight Credit that can be used for yourself or shared with someone else. [Learn more.](#)
-  Make sure you know [when to arrive at your airport](#). Times vary by city.
-  If your plans change, cancel your reservation at least 10 minutes before the original scheduled departure time of your flight to receive a [Transferable Flight Credit™](#). If you don't cancel your reservation in time, your funds will be forfeited.

Prepare for takeoff

Use our app to make changes to your trip, get a boarding pass, & more.



 Download app now

 Download app now



Travel Authorization & Expense Reporting Form

A.5.b

Instructions: **Prior to any travel**, complete **Part I** of this form to have travel and anticipated expenses approved. Submit a copy of this approved form with each payment expense submitted. **Upon returning** from travel, complete **Part II** of this form to confirm total expenses including any approved adjustments. Submit form to Accounts Payable within **15 days** of the travel end date. **Always use the most up-to-date Travel Form located on the City's Intranet**

Part I - Travel Authorization	Employee Signature <i>Elena Baca</i>	Immediate Supervisor Signature X
--------------------------------------	--	--

Name: Elena Baca - Santa Cruz	Purpose of Trip: League of California Cities 2023 Annual Conference
--------------------------------------	--

Job Title: District 1 Council Member	Destination: 1401 K St, Sacramento, CA 95814	Out of State <input type="checkbox"/>
---	---	---

Division: City Council	<i>Enter below the departing date and time then the return date and time. Per diem travel days will automatically be calculated.</i>
-------------------------------	--

GL Org Set(s) 1010100110011	% Split 100%	Split Total Equals 100%	Departure Date & Time: 9/20/23 7:15 AM	<i>Example:</i> 1/2/18 7:30 A
			Return Date & Time: 9/22/23 8:40 PM	<i>Example:</i> 1/2/18 5:30 P

Expense Type	Account #	Description of Expenses	Amount	CAL-Card <input type="checkbox"/> If Y
Registration:	(620510)	League of California Cities Conference Registration	\$650.00	<input checked="" type="checkbox"/>
Lodging :	(620510)	DoubleTree Hilton Hotel	\$364.00 <i>\$409.94</i>	<input checked="" type="checkbox"/>
Mileage:	(620510)	Miles: X Rate:		<input type="checkbox"/>
Airfare:	(620510)	Southwest Airlines ONT-->SMF SMF-->ONT	\$326.95	<input type="checkbox"/>
*Per Diem:	(620510)	Sacramento, CA	\$69	<input type="checkbox"/>
Total Travel Days (Enter # of Days) >>>			3	<input checked="" type="checkbox"/> Check box to decline Per Diem, whereby actual receipts must be submitted <i>paid</i> <i>EBC</i>
*To receive per diem, travel must include an overnight stay. Per diem on first and last day are to be calculated at 75% of daily per diem rate.			Total Per Diem:	
Misc. Other:	(620510)			<input type="checkbox"/>
Business Meals:	(620510)			<input type="checkbox"/>

Division Manager Approval X	Date X	Total Anticipated Expenses: \$1,503.45 <i>\$1,559.39</i>
Department Head Approval <i>[Signature]</i>	Date <i>9/19/23</i>	City Manager Approval (as required) X

Part II - Expense Reporting *(Please check the appropriate box below and provide details)*

- No adjustments are necessary. Anticipated expenses match actual expenses incurred.
- Advance **payments exceeded** the actual expenses incurred. Attached is my receipt as evidence of reimbursement to the City. (Explain below, use negative numbers)
- Actual **expenses exceeded** the anticipated original request. Additional funds are required as listed below.

Expense Details	Expenditure Code	Amount	CAL-Card?
Post-Trip I certify that this document is a true and accurate record of travel expenses for official City business.	Employee Signature: <i>Elena Baca</i> Date: <i>9/18/23</i>	1010100110011	\$1,503.45 <i>\$1,559.39</i>
Division Manager Approval X	Date X	Final Total Expenses:	\$1,559.39
Department Head Approval <i>[Signature]</i>	Date <i>9/28/23</i>	City Manager Approval (as required) X	Date X

Attachment: Elena Baca-Santa Cruz - Travel Authorization & Expense Report - League of Cal Cities_Redacted (6418 : COUNCIL TRAINING &

Invoice



Invoice Date

7/6/2023

Bill To:

Sonia Gomez
 15670 Perris Blvd
 Moreno Valley,CA 92551-4612

Ship To:

Sonia Gomez
 15670 Perris Blvd
 Moreno Valley,CA 92551-4612
 US

Invoice #	Customer #	Shipping Method	Purchase Order			
INV-04549-W8Y1C3	952835					
Description	Qty	Unit Price	Discount	Tax	Amount	
Early Bird Full Conference - Member City - Baca-Santa Cruz, Elena	1.00	\$650.00	\$0.00	\$0.00	\$650.00	
Visa - Authorized - Captured: 48	1.00	\$0.00	\$0.00	\$0.00	\$650.00	
Sub Total by US Dollar:					\$650.00	
Payments:					\$650.00	
Balance:					\$0.00	

Attachment: Elena Baca-Santa Cruz - Travel Authorization & Expense Report - League of Cal Cities_Redacted (6418 : COUNCIL TRAINING &



LEAGUE OF
CALIFORNIA
CITIES

125 YEARS
1898-2023

ANNUAL Conference and Expo

Sept. 20-22, 2023
Sacramento, CA





LEAGUE OF CALIFORNIA CITIES

MISSION

To expand and protect local control for cities through education and advocacy to enhance the quality of life for all Californians.

VISION

To be recognized and respected as the leading advocate for the common interests of California's cities.

WE BELIEVE

- ◆ Local self-governance is the cornerstone of democracy.
- ◆ Our strength lies in the unity of our diverse communities of interest.
- ◆ In the involvement of all stakeholders in establishing goals and in solving problems.
- ◆ In conducting the business of government with transparency, openness, respect, and civility.
- ◆ The spirit of honest public service is what builds communities.
- ◆ Open decision-making that is of the highest ethical standards honors the public trust.
- ◆ Cities are vital to the strength of the California economy.
- ◆ The vitality of cities is dependent upon their fiscal stability and local autonomy.
- ◆ The active participation of all city officials increases Cal Cities' effectiveness.
- ◆ Partnerships and collaborations are essential elements of focused advocacy and lobbying.
- ◆ Ethical and well-informed city officials are essential for responsive, visionary leadership, and effective and efficient city operations.



DOUBLETREE HOTEL SACRAMENTO
 2001 POINT WEST WAY
 SACRAMENTO, CA 95815
 United States of America
 TELEPHONE 916-929-8855 • FAX 916-929-4913
 Reservations
 www.doubletree.com or 1-800-222-TREE

A.5.b

SANTA CRUZ, ELENA



Room No: 2320/NKR
 Arrival Date: 9/20/2023 9:32:00 AM
 Departure Date: 9/22/2023 12:11:00 PM
 Adult/Child: 1/0
 Cashier ID: AURIBEVARGAS
 Room Rate: 177.00
 AL:
 HH # 266496942 BLUE
 VAT #
 Folio No/Che 1996459 B

Confirmation Number: 96967431

DOUBLETREE HOTEL SACRAMENTO 10/9/2023 1:07:00 PM

DATE	REF NO	DESCRIPTION	CHARGES
9/20/2023	7228215	GUEST ROOM	\$177.00
9/20/2023	7228215	OCCUPANCY TAX	\$21.24
9/20/2023	7228215	CITY TOURISM ASSESSMENT	\$4.43
9/20/2023	7228215	CITY INFRASTRUCTURE ASMT	\$1.77
9/20/2023	7228215	CA TOURISM ASSESSMENT	\$0.53
9/21/2023	7228624	GUEST ROOM	\$177.00
9/21/2023	7228624	OCCUPANCY TAX	\$21.24
9/21/2023	7228624	CITY TOURISM ASSESSMENT	\$4.43
9/21/2023	7228624	CITY INFRASTRUCTURE ASMT	\$1.77
9/21/2023	7228624	CA TOURISM ASSESSMENT	\$0.53
9/22/2023	7228947	VS *1322	(\$409.94)
BALANCE			\$0.00

FOLLOW US ON FACEBOOK AND TWITTER!

CREDIT CARD DETAIL
 APPR CODE 077020 MERCHANT ID 67057170011
 CARD NUMBER VS *1322 EXP DATE 11/23
 TRANSACTION ID 7228947 TRANS TYPE Sale

Attachment: Elena Baca-Santa Cruz - Travel Authorization & Expense Report - League of Cal Cities_Redacted (6418 : COUNCIL TRAINING &

Ivette Andrade

From: Southwest Airlines <southwestairlines@ifly.southwest.com>
Sent: Monday, September 18, 2023 1:29 PM
To: City Clerk Staff_DG
Subject: Elena Victoria Santa Cruz's 09/20 Sacramento trip (4QW3E7): Your change is confirmed.

Warning: External Email – Watch for Email Red Flags!

Here's your updated itinerary and trip receipt.
[View our mobile site](#) | [View in browser](#)



[Manage Flight](#) | [Flight Status](#) | [My Account](#)



Hi Elena Victoria,

We've confirmed the change to your trip. Below you'll find your updated itinerary, important travel information, and trip receipt. See you onboard soon!

SEPTEMBER 20 - SEPTEMBER 22

ONT ✈ **SMF**

Ontario to Sacramento

Confirmation # **4QW3E7**

Confirmation date: 09/18/2023

PASSENGER	Elena Victoria Santa Cruz
RAPID REWARDS #	Join or Log in
TICKET #	5262203106933
EST. POINTS EARNED	0

Rapid Rewards® points are only estimations.

Your itinerary

Flight 1: Wednesday, 09/20/2023 Est. Travel Time: 1h 25m [Anytime](#)

FLIGHT # 2261	DEPARTS ONT 07:15AM Ontario	✈	ARRIVES SMF 08:40AM Sacramento
----------------------	---	---	--

Flight 2: Friday, 09/22/2023 Est. Travel Time: 1h 20m [Anytime](#)



FLIGHT # 2826	DEPARTS		ARRIVES
	SMF 07:20PM Sacramento		ONT 08:40PM Ontario

Payment information

Total cost		Payment
Air - 4QW3E7		Credit from ticket: #5262203105091 to #5262203106933 Date: July 11, 2023
Base Fare	\$ 276.42	
U.S. Transportation Tax	\$ 20.73	
U.S. 9/11 Security Fee	\$ 11.20	
U.S. Flight Segment Tax	\$ 9.60	
U.S. Passenger Facility Chg	\$ 9.00	
Total	\$ 326.95	

Fare rules: If you decide to make a change to your current itinerary it may result in a fare increase.
 Your ticket number: 5262203106933

All your perks, all in one place. (Plus a few reminders.)

-  **Anytime fare:** Your two bags fly free®, no change or cancel fees, 10X Rapid Rewards® points, refundable, and EarlyBird automatic check-in. [Learn more.](#)
-  Make sure you know when to arrive at your airport. Times vary by city.
-  If your plans change, cancel your reservation at least 10 minutes before original scheduled departure time and request your refund. If you don't cancel your reservation in time, you'll receive a Transferable Flight Credit™.

Prepare for takeoff

Use our app to make changes to your trip, get a boarding pass, & more.

 [Download app now](#)
 [Download app now](#)

Attachment: Elena Baca-Santa Cruz - Travel Authorization & Expense Report - League of Cal Cities_Redacted (6418 : COUNCIL TRAINING &



Travel Authorization & Expense Reporting Form

A.5.c

Instructions: **Prior to any** travel, complete **Part I** of this form to have travel and anticipated expenses approved. Submit a copy of this approved form with each payment expense submitted. **Upon returning** from travel, complete **Part II** of this form to confirm total expenses including any approved adjustments. Submit form to Accounts Payable within **15 days** of the travel end date. **Always use the most up-to-date Travel Form located on the City's Intranet**

Part I - Travel Authorization	Employee Signature <i>[Signature]</i>	Immediate Supervisor Signature X
--------------------------------------	--	-------------------------------------

Name: David Marquez	Purpose of Trip: League of Cal Cities - 2023 Annual Conference	
Job Title: Council Member - District 3	Destination: 1209 L Street Sac	Out of State? <input type="checkbox"/>

Division: City Council
Enter below the departing date and time then the return date and time. Per diem travel days will automatically be calculated.

GL Org Set(s)	% Split	Split Total Equals	Departure Date & Time:	9/20/23 9:40 AM	Example: 1/2/18 7:30 AM
10013-620510	100%		Return Date & Time:	9/22/23 6:00PM	Example: 1/2/18 5:30 PM
100%					

Expense Type	Account #	Description of Expenses	Amount	CAL-Card If Ye <input checked="" type="checkbox"/>
Registration:	(620510)	League of Cal Cities - Early Bird Conference	\$650.00	<input checked="" type="checkbox"/>
Lodging :	(620510)	Double Tree by Hilton	\$483.08	<input checked="" type="checkbox"/>
Mileage:	(620510)	Miles: X Rate: \$0.655		<input type="checkbox"/>
Airfare:	(620510)	Southwest ONT -> SMF	\$282.96	<input checked="" type="checkbox"/>
*Per Diem:	(620510)	Sacramento	\$69	<input type="checkbox"/>

Total Travel Days (Enter # of Days) >>> 3

**To receive per diem, travel must include an overnight stay.*

Per diem on first and last day are to be calculated at 75% of daily per diem rate.

Total Per Diem: \$172.50

Misc. Other: (620510)

Business Meals: (620510)

Division Manager Approval	Date	Total Anticipated Expenses:	\$1,588.54
X	X	City Manager Approval (as required)	Date
Department Head Approval	Date		
X <i>[Signature]</i>	X 8/10/23	X	X

Part II - Expense Reporting (Please check the appropriate box below and provide details)

- No adjustments are necessary. Anticipated expenses match actual expenses incurred.
- Advance **payments exceeded** the actual expenses incurred. Attached is my receipt as evidence of reimbursement to the City. (Explain below, use negative numbers)
- Actual **expenses exceeded** the anticipated original request. Additional funds are required as listed below.

Expense Details	Expenditure Code	Amount	CAL-Card?
<i>Executed cancellations of all expenses; except for the LOCC conference registration fee. Ineligible for refund due to LOCC deadline of September 5 2023</i>			<input type="checkbox"/>
Post-Trip	10013-620510	\$1,588.54	<input checked="" type="checkbox"/>
Employee Signature: <i>[Signature]</i>	GL Org Set		
Date:	Split Totals:		
Ext.:			

Division Manager Approval	Date	Final Total Expenses:	\$1,588.54 \$650.00
X	X	City Manager Approval (as required)	Date
Department Head Approval	Date		
X <i>[Signature]</i>	X 10/11/23	X	X

Attachment: David Marquez - Travel Authorization & Expense Report - League of Cal Cities (6418 : COUNCIL TRAINING & TRAVEL



Invoice Date
6/1/2023

Bill To:
Patrick Killion
14177 Frederick St
Moreno Valley, CA 92553-9014

Ship To:
Patrick Killion
14177 Frederick St
Moreno Valley, CA 92553-9014
US

Invoice #	Customer #	Shipping Method	Purchase Order
-----------	------------	-----------------	----------------

INV-03263-S3Q3Q6

71916

Description	Qty	Unit Price	Discount	Tax	Amount
Cancellation Fee <i>Council Member Marquez</i>	1.00	\$650.00	\$0.00	\$0.00	\$650.00
Visa - Authorized - Captured: 20	1.00	\$0.00	\$0.00	\$0.00	\$650.00

Sub Total by US Dollar: \$650.00
Payments: \$650.00
Balance: \$0.00

Attachment: David Marquez - Travel Authorization & Expense Report - League of Cal Cities (6418 : COUNCIL TRAINING & TRAVEL



LEAGUE OF
CALIFORNIA
CITIES

125 YEARS
1898-2023

ANNUAL Conference and Expo

Sept. 20-22, 2023
Sacramento, CA

Attachment: David Marquez - Travel Authorization & Expense Report - League of Cal Cities (6418 : COUNCIL TRAINING & TRAVEL



LEAGUE OF CALIFORNIA CITIES

MISSION

To expand and protect local control for cities through education and advocacy to enhance the quality of life for all Californians.

VISION

To be recognized and respected as the leading advocate for the common interests of California's cities.

WE BELIEVE

- ◆ Local self-governance is the cornerstone of democracy.
- ◆ Our strength lies in the unity of our diverse communities of interest.
- ◆ In the involvement of all stakeholders in establishing goals and in solving problems.
- ◆ In conducting the business of government with transparency, openness, respect, and civility.
- ◆ The spirit of honest public service is what builds communities.
- ◆ Open decision-making that is of the highest ethical standards honors the public trust.
- ◆ Cities are vital to the strength of the California economy.
- ◆ The vitality of cities is dependent upon their fiscal stability and local autonomy.
- ◆ The active participation of all city officials increases Cal Cities' effectiveness.
- ◆ Partnerships and collaborations are essential elements of focused advocacy and lobbying.
- ◆ Ethical and well-informed city officials are essential for responsive, visionary leadership, and effective and efficient city operations.

From: [Megan Dunn](#)
To: [Patrick Killion](#)
Cc: [City Clerk Staff_DG](#)
Subject: RE: Cancellation: Council Member Marquez
Date: Wednesday, September 27, 2023 2:12:25 PM
Attachments: [image002.png](#)

Warning: External Email – Watch for Email Red Flags!

This cancellation was received after our published deadline of September 5 and is therefore ineligible for a refund.

Thank you,

Looking ahead: I will be on vacation October 2 - 6

Megan Dunn
 Senior Associate, Event Registration

League of California Cities
 1400 K Street, Suite 400
 Sacramento, CA 95814
 Office: 916-658-8291
mdunn@calcities.org | www.calcities.org



[Twitter](#) | [Facebook](#) | [YouTube](#) | [LinkedIn](#)

From: Patrick Killion <patrickk@moval.org>
Sent: Tuesday, September 19, 2023 7:10 PM
To: Megan Dunn <mdunn@calcities.org>
Cc: City Clerk Staff_DG <cityclerkstaff@moval.org>
Subject: Cancellation: Council Member Marquez

CAUTION: This email originated from outside our organization. Exercise caution when replying, opening attachments or clicking links.

Good Afternoon Megan,

I know it's quite late into the game, but I've got a recent cancellation from Council Member Marquez for his attendance at the Cal Cities Annual Conference. I've cancelled all of his accommodations, but would it be possible to cancel and maybe get a refund for his registration?

Best,

Patrick Killion
Administrative Assistant
Mayor & City Council Offices
City of Moreno Valley

p: [951.413.3008](tel:951.413.3008) | e: patrickk@moval.org w: www.moval.org
14177 Frederick St., Moreno Valley, CA, 92553



Attachment: David Marquez - Travel Authorization & Expense Report - League of Cal Cities (6418 : COUNCIL TRAINING & TRAVEL



Report to City Council

TO: Mayor and City Council

FROM: Jane Halstead, CMC, City Clerk

AGENDA DATE: October 17, 2023

TITLE: ADOPT ORDINANCE NO. 1002 ADDING CHAPTER 2.66 "ELECTRONIC FILING OF CAMPAIGN DISCLOSURE STATEMENTS," RELATING TO ELECTRONIC FILING OF FAIR POLITICAL PRACTICES COMMISSION STATEMENTS

RECOMMENDED ACTION

Recommendation:

1. That the City Council adopt Ordinance No. 1002 - an Ordinance adding Chapter 2.66, "Electronic Filing of Campaign Disclosure Statement" to the Moreno Valley Municipal Code.

SUMMARY/DISCUSSION

On October 3, 2023 Ordinance No. 1002 was introduced and the first reading was waived by a 5-0 vote.

The City Clerk serves as the filing officer for the City of Moreno Valley, and is responsible for receiving, reviewing, and storing campaign disclosure information, as well as making it accessible to the public. The City Clerk's office currently accepts paper filings of such documents and has them uploaded to the City website. Assembly Bill (AB) 2151 requires cities to post any campaign statement, report, or other document required by the Political Reform Act to their websites within 72 hours of its filing.

Government Code Section 84615, part of the Political Reform Act authorizes the City to require elected and appointed officials, candidates and/or campaign committees to file FPPC (Fair Political Practices Commission) campaign statements, reports, or other documents online or electronically with a local filing officer, which in our case is the City Clerk.

However, in order for the City to accept electronic filed statements, the City Council must adopt an ordinance (attachment 1) approving the use of an online or electronic filing system, which must include the finding that the online or electronic system will operate securely and effectively and will not unduly burden filers. The proposed ordinance would require electronic filing of campaign disclosure statements with the City, which would streamline the campaign filing process.

Staff has identified a vendor, Netfile, to facilitate the electronic filing system that accommodates online filing of several types of FPPC forms, including Forms 460, 470, 496, and 497, and meets the requirements of the Secretary of State that ensures NetFile's compliance with AB 2151. The vendor also provides electronic filing of Statements of Economic Interest (Form 700) along with a free public viewing portal. The City has applied for certification from the FPPC for electronic filing of Statements of Economic Interests. (Attached).

Netfile will also be utilized for electronic/paperless filing for all Form 700s (Statements of Economic Interest). However, adoption of an ordinance is not required for the use of an electronic filing system for Form 700s.

In terms of security, the NetFile system is a web-based, vendor-hosted application that utilizes "industry best practices" for securing data, using the same data encryption for online filings that is used by banks for online banking. NetFile stores and backs up data at three separate locations, creating the essential safety measures and redundancy that allows for recovery of information in the event of an emergency or disaster.

Implementation of the NetFile system will promote public transparency, and time and cost savings for staff, and provide convenience for committees, individuals, and the public. It also provides 24-hour filing and viewing accessibility of campaign finance information from any computer, anywhere. In certain instances, the NetFile system will also increase the accuracy of filed campaign statements by prohibiting any filings that may have inadvertently omitted information required under the Political Reform Act. To ensure a smooth transition, NetFile and the City Clerk's Office will offer extensive training to all filers. There are currently 180 cities and 32 counties in California electronically filing Campaign Disclosure Statements through NetFile.

If adopted, the ordinance would become effective 30 days after adoption (second reading). The next campaign disclosure statements are due January 31, 2024.

FISCAL IMPACT

There is no fiscal impact associated with the recommended action. The cost of the vendor has been approved in the FY 2024-25 Budget for the remainder of this fiscal year and will be included as part of the budget process in subsequent years. The FPPC charges a fee of \$1,000 on a city to implement electronic filing, which is covered by the vendor. The proposed vendor offers a price of \$12,250 per year for up to five years.

NOTIFICATION

Publication of the Agenda

PREPARATION OF STAFF REPORT

Prepared By:
Jane Halstead
City Clerk

CITY COUNCIL GOALS

Positive Environment. Create a positive environment for the development of Moreno Valley's future.

ATTACHMENTS

None

CITY COUNCIL GOALS

None

CITY COUNCIL STRATEGIC PRIORITIES

1. Economic Development
2. Public Safety
3. Library
4. Infrastructure
5. Beautification, Community Engagement, and Quality of Life
6. Youth Programs

ATTACHMENTS

To view large attachments, please click your “bookmarks”  on the left hand side of this document for the necessary attachment.

Proposed ordinance

APPROVALS

CITY COUNCIL GOALS

None

CITY COUNCIL STRATEGIC PRIORITIES

1. Economic Development
2. Public Safety

- 3. Library
- 4. Infrastructure
- 5. Beautification, Community Engagement, and Quality of Life
- 6. Youth Programs

ATTACHMENTS

To view large attachments, please click your “bookmarks”  on the left hand side of this document for the necessary attachment.

- 1. NETFILE ORDINANCE

APPROVALS

Budget Officer Approval	<u>✓ Approved</u>	10/10/23 8:49 AM
City Attorney Approval	<u>✓ Approved</u>	
City Manager Approval	<u>✓ Approved</u>	10/10/23 8:51 AM

ORDINANCE NO. _____

AN ORDINANCE OF THE CITY OF MORENO VALLEY CITY ADDING CHAPTER 2.66 “ELECTRONIC FILING” TO THE MORENO VALLEY MUNICIPAL CODE REGARDING PAPERLESS FILINGS OF CERTAIN STATEMENTS, REPORTS AND DOCUMENTS REQUIRED PURSUANT TO THE POLITICAL REFORM ACT AND/OR THE FAIR POLITICAL PRACTICES COMMISSION REGULATIONS

WHEREAS, Government Code Section 84615 currently provides that a local agency may adopt an ordinance to require an elected officer, candidate, committee, or other person required to file statements, reports, or other documents required by Chapter 4 of the Political Reform Act (commencing with Section 84100 of the Government Code), excluding elected officers, candidates, committees, or other persons who receive contributions totaling less than \$2,000 and who makes independent expenditures totaling less than \$2,000 in a calendar year, to file those statements, reports, or other documents online or electronically with the local filing officer; and

WHEREAS, the City expressly finds that NetFile, Inc. is a vendor is approved by the California Secretary of State to provide an online electronic filing system ("System") for campaign disclosure statements; and

WHEREAS, the City of Moreno Valley desires to amend the Moreno Valley City Municipal Code to add Chapter 2.66 “Electronic Filing” to the Moreno Valley Municipal Code regarding the electronic filing of certain statements, reports, or other documents required pursuant to the Political Reform Act and/or the Fair Political Practices Commission Regulations.

NOW THEREFORE, THE CITY COUNCIL OF THE CITY OF MORENO VALLEY DOES ORDAIN AS FOLLOWS:

Section 1. Recitals

That the above recitals are true and correct and are incorporated as though fully set forth herein.

Section 2. Findings

The City Council of the City of Moreno Valley finds that the System will operate securely and effectively and will not unduly burden filers since: (1) the System will ensure the integrity of the data and includes safeguards against efforts to tamper with, manipulate, alter, or subvert the data; (2) the System will only accept a filing in the standardized record format developed by the Secretary of State and that is compatible with the Secretary of State's system for receiving an online or electronic filing; and (3) the System will be available free of charge to filers and to the public for inspection and viewing purposes.

Section 3. Amendment

Title 2, "Administration and Personnel" of the Moreno Valley Municipal Code is hereby amended to add Chapter 2.66, "Electronic Filing" as follows:

Chapter 2.66 ELECTRONIC FILING

Sections:

2.66.010 Electronic and Paperless Filing of Fair Political Practices Commission Campaign Disclosure Statements

A. Purpose and intent. The purpose and intent of this chapter is to allow elected officers, candidates, commissioners, committees, and other persons required to file campaign disclosure statements, reports, forms or other documents required by Political Reform Act or the Fair Political Practices Commission Regulations to efficiently file such records electronically using the city's approved electronic filing system and to promote public transparency by facilitating review and inspection of said records by members of the general public and other interested parties, using an electronic filing system that ensures the integrity of the data transmitted through the implementation of various safeguards against efforts to tamper with, manipulate, alter, or subvert the data.

B. Electronic filing. Any elected officer, candidate, commissioner, committee, or other person required to file campaign disclosure statements, reports, forms or other documents required under the Political Reform Act or the Fair Political Practices Commission Regulations shall file such records online or electronically using the city's approved electronic filing system.

C. No filing fees. No filing fee is required for the electronic filing of any of the statements, reports, forms or other documents covered by this chapter.

D. Exemption from electronic filing. Pursuant to Government Code Section 84615(a) officers, candidates, committees or persons who receive less than \$2,000 in contributions and makes less than \$2,000 in expenditures in a calendar year shall be exempt from the electronic filing requirements set forth in this chapter.

E. Standardized record formats. Filers shall file any required statements, reports, forms and other documents covered by this chapter in the standardized record format developed by the California Secretary of State that are compatible with the Secretary of State's system for receiving online or electronic filings.

F. Original filings. If an original statement, report, form or other document required under Political Reform Act or the Fair Political Practices Commission Regulations is required to be filed with the California Secretary

of State with a duplicate or copy filed with the City Clerk, the filer may, but is not required to, file a copy of the same electronically using the city's approved electronic filing system.

G. Duplicates. Any elected officer, candidate, commissioner or committee or person who has electronically filed a statement, report, form or other document covered by this chapter using the city's electronic filing system is not required to file a duplicate copy of that document in paper format with the City Clerk.

H. Sign under penalty of perjury. All statements, reports, forms or other documents covered by this chapter shall be signed by the respective filer under penalty of perjury pursuant to Section 81004 of the Government Code.

I. Filing confirmation. The City Clerk will issue an electronic confirmation that notifies the filer of the date and time his or her statement, report, form or other document was filed electronically. The date of filing for any records filed online shall be the day that it is received by the City Clerk. The City Clerk will also notify the filer of the method by which the filer may view and print any related data received by the City Clerk.

J. Technical difficulties. If the electronic filing system is not capable of accepting a record due to technical difficulties, the filer shall timely file the record in paper format with the City Clerk, unless otherwise directed by the City Clerk.

K. Public disclosure and inspection. The contents of any statements, reports, forms or other documents covered by this chapter which have been electronically filed pursuant will be made available on the City's webpage in an easily understood format that provides the greatest public access. Any data related to any of the electronically filed records will be made available free of charge for public viewing and inspection as soon as possible after receipt of any request to view and inspect said records. The records made available on the City's webpage will be redacted to remove street names and building numbers associated with the addresses of any persons or representatives and bank account numbers identified in any electronically filed records.

2.66.20 Definitions

The following definitions apply for the purposes of this chapter.

"Candidate" shall mean a candidate, as that phrase is defined in Section 82007 of the Government Code, as may be amended from time to time, for any City elective office for any general, special or recall election.

"Committee" has the meaning set forth in Section 82013 of the Government Code, as may be amended from time to time.

"Contribution" has the meaning set forth in Section 82015 of the Government Code, as may be amended from time to time.

"Electronic filing system" shall mean the electronic online filing and data storage system provided for by the City Clerk for campaign statements, reports, forms, or other documents filed pursuant to Government Code Section 81000 et seq.

"Person" has the meaning set forth in Section 82047 of the Government Code, as may be amended from time to time.

"Statements" shall mean any statements, reports, forms or other documents required by Government Code Chapter 4 – Political Reform Act (Section 81000 et seq.), as may be amended from time to time.

2.66.30 Retention

The City Clerk's office will maintain, for a period of at least 10 years commencing from the date filed, a secured, official version of each statement filed on the city's electronic filing system, which shall serve as the official version of that record for purpose of audits and any other legal purpose.

2.66.40 Policies and procedures.

The City Clerk is authorized to adopt such administrative policies and procedures as deemed necessary by the City Clerk to implement the provisions of this chapter.

Section 3. Severability

That the City Council declares that, should any provision, section, paragraph, sentence or word of this Ordinance be rendered or declared invalid by any final court action in a court of competent jurisdiction or by reason of any preemptive legislation, the remaining provisions, sections, paragraphs, sentences or words of this Ordinance as hereby adopted shall remain in full force and effect.

Section 4. Repeal of Conflicting Provisions

That all the provisions heretofore adopted by the City Council that are in conflict with the provisions of this Ordinance, are hereby repealed.

Section 5. Effective Date

That this Ordinance shall take effect thirty (30) days after its second reading.

Section 6. Certification

That the City Clerk shall certify to the passage and adoption of this Ordinance, enter the same in the book for original ordinances of the City, and make a minute of passage and adoption thereof in the records of the proceedings of the City Council, in the minutes of the meeting at which this Ordinance is passed and adopted.

APPROVED AND ADOPTED this ____ day of _____ 2023, by the following vote:

AYES:

NOES:

ABSENT:

ABSTAIN:

Ulises Cabrera
Mayor
City of Moreno Valley

ATTEST:

Jane Halstead, City Clerk

APPROVED AS TO FORM:

Steven B. Quintanilla
Interim City Attorney

Attachment: NETFILE ORDINANCE (6419 : ORDINANCE ADDING CHAPTER 2.66 "ELECTRONIC FILING OF)



Report to City Council

TO: Mayor and City Council Moreno Valley Community Foundation (MVCF)

FROM: Brian Mohan, Assistant City Manager

AGENDA DATE: October 17, 2023

TITLE: MORENO VALLEY COMMUNITY FOUNDATION - HOMELESS COMMUNITY OUTREACH PILOT PROGRAM

RECOMMENDED ACTION

Recommendations:

1. Authorize the Vice President (Assistant City Manager) and Treasurer (CFO/Treasurer) to create the Moreno Valley Community Foundation Homeless Community Outreach Pilot Program as identified in the attached Resolution, and
2. Adopt Resolution 2023- XX describing the Community Outreach Pilot Program, and
3. Authorize the Vice President to execute any Agreements with the Community Based Organizations (CBO's) as a part of the Pilot Program and any subsequent Amendments to the Agreement within Board approved annual budgeted amounts, including the authority to authorize the associated purchase orders in accordance with the terms of the Agreement, subject to the approval of the City Attorney, and
4. Authorize the Treasurer to process a budget amendment and appropriation as shown in the Fiscal Impact section of the report.

SUMMARY

In light of the significant restrictiveness of the annual Housing and Urban Development (HUD) Entitlement funds and the inability of most of our Community Based Organizations (CBO's) to qualify for the Community Development Block Grant (CDBG), HOME Investment Partnership Program, and Emergency Solutions Grant (ESG), the Vice President (Assistant City Manager) of the Moreno Valley Community Foundation

(MVCF) recommends creating a Homeless Outreach Pilot Program to enable these CBO's an ability to qualify for a less restrictive funding source. One aspect of the restrictiveness of these funds is a match requirement for certain categories of these funds as the CBO's cannot/do not have any matching funds in order to qualify.

DISCUSSION

For years now, there have been several CBO's that have applied for the HUD Entitlement Funds included CDBG, HOME, and ESG, but have not qualified due to the restrictiveness or matching requirements.

Since the Foundation is has received additional Community Benefits from the development community, it is the recommendation of the Vice President to create and fund a Homeless Community Outreach Pilot Program that will allow these CBO's the ability to qualify for less restrictive funding that does not require any matching requirements.

ALTERNATIVES

1. Approve the recommended actions as presented in this staff report. Staff recommends this alternative as it will have a positive impact on the homeless community by providing funding for the Homeless Community Outreach Pilot Program.

2. Do not approve the recommended actions as presented in this staff report. Staff does not recommend this alternative as it will not provide the opportunity for funding to the Homeless Community Outreach Pilot Program.

FISCAL IMPACT

The Homeless Community Outreach Pilot Program will be funded by Community Benefit funds received by the development community in the amounts below.

Description	Fund	GL Account No.	Type (Rev/Exp)	FY 23/24 Budget	Proposed Adjustments	FY 23/24 Amended Budget	FY 24/25 Budget	Proposed Adjustments	FY 24/25 Amended Budget
Homeless Community Outreach Pilot Program	MVCF	4016-16-18-16311-625099	Exp	\$0	\$105,000	\$105,000	\$0	\$105,000	\$105,000

NOTIFICATION

Publication of Agenda.

PREPARATION OF STAFF REPORT

Prepared By:

Department Head Approval:

Name: Brian Mohan
Title: Vice President (Assistant City Manager)

Name: Brian Mohan
Title: Vice President (Assistant City Manager)

CITY COUNCIL GOALS

Public Safety. Provide a safe and secure environment for people and property in the community, control the number and severity of fire and hazardous material incidents, and provide protection for citizens who live, work and visit the City of Moreno Valley.

Positive Environment. Create a positive environment for the development of Moreno Valley's future.

Community Image, Neighborhood Pride and Cleanliness. Promote a sense of community pride and foster an excellent image about our City by developing and executing programs which will result in quality development, enhanced neighborhood preservation efforts, including home rehabilitation and neighborhood restoration.

CITY COUNCIL STRATEGIC PRIORITIES

- 1. Economic Development
- 2. Public Safety
- 3. Library
- 4. Infrastructure
- 5. Beautification, Community Engagement, and Quality of Life
- 6. Youth Programs

ATTACHMENTS

To view large attachments, please click your “bookmarks”  on the left hand side of this document for the necessary attachment.

- 1. 10.17.23 - MVCF Resolution 2023-XX

APPROVALS

Budget Officer Approval	<u>✓ Approved</u>	10/09/23 8:28 AM
City Attorney Approval	<u>✓ Approved</u>	
City Manager Approval	<u>✓ Approved</u>	10/09/23 9:02 AM

RESOLUTION NO. MVCF 2023-XX

A RESOLUTION OF THE MORENO VALLEY COMMUNITY FOUNDATION OF THE CITY OF MORENO VALLEY OF THE CITY OF MORENO VALLEY, CALIFORNIA, ADOPTING THE HOMELESS COMMUNITY OUTREACH PILOT PROGRAM 2023/24 – 2024/25

WHEREAS, the City Manager has heretofore submitted to the Mayor and City Council of the City of Moreno Valley as the Board of Directors of the Moreno Valley Community Foundation a Proposed Budget for the Foundation for Fiscal Years 2023/24 – 2024/25, a copy of which, as may have been amended by the Board of Director's, is on file in the Office of the City Clerk and is available for public inspection; and

WHEREAS, the said Proposed Budget contains estimates of the services, activities and projects comprising the budget, and contains expenditure requirements and the resources available to the Foundation; and

WHEREAS, the said Proposed Budget contains the estimates of uses of fund balance as required to stabilize the delivery of Foundation's services; and

WHEREAS, the Mayor and City Council of the City of Moreno Valley as Board of Director's to the Moreno Valley Community Foundation have made such revisions to the Proposed Budget as so desired; and

WHEREAS, the Proposed Budget, as herein approved, will enable the Foundation to make adequate financial plans and will ensure that Foundation Directors can administer their respective functions in accordance with such plans; and

WHEREAS, the Foundation approves appropriations at the fund level, the City Manager may transfer appropriations, between departments and within their respective funds, as long as those appropriations do not exceed their fund total unless approved by Foundation; and

WHEREAS, the Board of Director's find that funding a Homeless Community Outreach Pilot Program would provide Community Based Organizations the ability to continue to further expand the services they provide in this need population of residents; and

WHEREAS, the Board of Directors's find it advantages to utilize certain Community Benefit Donations received by the Development Community to fund the Homeless Community Outreach Pilot Program due to the significant restrictiveness of the annual Housing and Urban Development (HUD) Entitlement funds and the inability of most of our Community Based Organizations to qualify as one of the factors is the need to have matching fund ; and

1
Resolution No. MVCF 2023-XX
Date Adopted: October 17, 2023

WHEREAS, the Board of Director's authorize the Vice President (Assistant City Manager) and Treasurer (CFO/Treasurer) to create the Homeless Community Outreach Pilot Program to further the Boards findings.

NOW, THEREFORE, THE MORENO VALLEY COMMUNITY FOUNDATION OF THE CITY OF MORENO VALLEY, CALIFORNIA, DOES HEREBY RESOLVE AS FOLLOWS:

1. The Homeless Community Outreach Pilot Program will run for two years to align with the Fiscal Years 2023/24 – 2024/25 Budget Cycle.
2. The Pilot Program will be funded at \$105K in each of the budget years for a total of \$210K for the entire program.
3. The Pilot Program will include Building Up Lives, Hole in the Wall, and Inland Compassion, all of whom are Community Based Organizations located in Moreno Valley and each will be funded \$35K in each year of the Pilot Program.
4. Each of the Community Based Organizations will need to enter into a contractual agreement with the City, which will include, but not limited to, quarterly reporting requirements to Council and an annual presentation to Council.
5. Pursuant to Section 53901 of the California Government Code, by no later than August 30, 2021, the City Clerk shall file a copy of this Resolution with the Auditor/Controller of the County of Riverside.
6. Within fifteen (15) days after the adoption of this Resolution, the City Clerk shall certify to the adoption hereof and, as so certified, cause a copy to be posted in at least three (3) public places within the City.

APPROVED AND ADOPTED this 17th day of October, 2023.

Mayor of the City of Moreno Valley

ATTEST:

City Clerk

APPROVED AS TO FORM:

City Attorney

RESOLUTION JURAT

STATE OF CALIFORNIA)
COUNTY OF RIVERSIDE) ss.
CITY OF MORENO VALLEY)

I, Jane Halstead, City Clerk of the City of Moreno Valley, California, do hereby certify that Resolution No. MVCF 2023-XX was duly and regularly adopted by the Board of Directors of the Moreno Valley Community Foundation at a regular meeting thereof held on the 17th day of October, 2023 by the following vote:

AYES:

NOES:

ABSENT:

ABSTAIN:

(Council Members, Mayor Pro Tem and Mayor)

SECRETARY

(SEAL)



Report to City Council

TO: Mayor and City Council

FROM: Brian Mohan, Assistant City Manager

AGENDA DATE: October 17, 2023

TITLE: LIST OF PERSONNEL CHANGES

RECOMMENDED ACTION

Recommendation:

1. Ratify the list of personnel changes as described.

DISCUSSION

The attached list of personnel changes scheduled since the last City Council meeting is presented for City Council ratification.

Staffing of City positions ensures assignment of highly qualified and trained personnel to achieve Momentum MoVal priorities, objectives and initiatives.

FISCAL IMPACT

All position changes are consistent with appropriations previously approved by the City Council.

PREPARATION OF STAFF REPORT

Prepared By:
Serina Astorga
Executive Assistant

Department Head Approval:
Brian Mohan
Assistant City Manager
Chief Financial Officer/City Treasurer

CITY COUNCIL GOALS

None

CITY COUNCIL STRATEGIC PRIORITIES

- 1. Economic Development
- 2. Public Safety
- 3. Library
- 4. Infrastructure
- 5. Beautification, Community Engagement, and Quality of Life
- 6. Youth Programs

ATTACHMENTS

To view large attachments, please click your “bookmarks”  on the left hand side of this document for the necessary attachment.

- 1. Personnel Changes for Staff Report_10.17.23

APPROVALS

Budget Officer Approval	<u>✓ Approved</u>	10/10/23 7:52 AM
City Attorney Approval	<u>✓ Approved</u>	
City Manager Approval	<u>✓ Approved</u>	10/10/23 8:23 AM

City of Moreno Valley
Personnel Changes- 9/1/23- 9/30/23
October 17,2023

New Hires

Allen Lopez, Recycling Specialist, Purchasing, Financial and Management Services

Promotions

Anna Chacon

From: Management Analyst, Purchasing, Financial and Management Services

To: Purchasing Division Manager, Purchasing, Financial and Management Services

Mayra Fragozo

From: Senior Office Assistant, Community Enhancement and Neighborhood Services, Community Development

To: Sr. Administrative Assistant, City Manager's Office

Transfers

Dean Ayer

From: Sr. Management Analyst, Electric Utility, Public Works

To: Sr. Management Analyst, Public Works Administration, Public Works

Joseph Mattox

From: Maintenance and Operations Division Manager, Maintenance and Operations, Public Works

To: Fleet & Facilities Division Manager, Fleet and Facilities Maintenance, Public Works

Separations

Joseph Bolognesi, Animal Control Officer, Animal Services, Community Development



Report to City Council

TO: Mayor and City Council

FROM: Brian Mohan, Assistant City Manager

AGENDA DATE: October 17, 2023

TITLE: PAYMENT REGISTER - AUGUST 2023

RECOMMENDED ACTION

Recommendation:

1. Receive and file the Payment Register.

SUMMARY

The Payment Register is an important report providing transparency of financial transactions and payments for City activity for review by the City Council and the residents and businesses in Moreno Valley. The report is posted to the City's website as soon as it is available. The report is included in the City Council agenda as an additional means of distributing the report.

The payment register lists in alphabetical order all checks and wires in the amount of \$25,000 or greater, followed by a listing in alphabetical order of all checks and wires less than \$25,000. The payment register also includes the fiscal year-to-date (FYTD) amount paid to each vendor.

PREPARATION OF STAFF REPORT

Prepared By:
Annabelle Wang
Financial Operations Division Manager

Department Head Approval:
Brian Mohan
Assistant City Manager
Chief Financial Officer
Treasurer

CITY COUNCIL GOALS

None

CITY COUNCIL STRATEGIC PRIORITIES

- 1. Economic Development
- 2. Public Safety
- 3. Library
- 4. Infrastructure
- 5. Beautification, Community Engagement, and Quality of Life
- 6. Youth Programs

ATTACHMENTS

To view large attachments, please click your “bookmarks”  on the left hand side of this document for the necessary attachment.

- 1. August2023PaymentRegisterSR

APPROVALS

Budget Officer Approval	<u>✓ Approved</u>	10/09/23 8:43 AM
City Attorney Approval	<u>✓ Approved</u>	
City Manager Approval	<u>✓ Approved</u>	10/09/23 9:03 AM



**City of Moreno Valley
Payment Register
For Period 8/1/2023 through 8/31/2023**

CHECKS IN THE AMOUNT OF \$25,000 OR GREATER

<u>Vendor Name</u>	<u>Check/EFT Number</u>	<u>Payment Date</u>	<u>Inv Number</u>	<u>Invoice Description</u>	<u>Payment Amount</u>
4LEAF, INC	245928	08/02/2023	J3988I	PLANNING SERVICES-DECEMBER 2022	\$28,770.00
		08/02/2023	J3988L	PLANNING SERVICES-MARCH 2023	
		08/02/2023	J3988O	PLANNING SERVICES-JUNE 2023	
Remit to: PLEASANTON, CA					<u>FYTD:</u> \$47,840.00
ACCO ENGINEERED SYSTEMS, INC	37963	08/02/2023	20427195	HVAC PREV MAINTENANCE-CONFERENCE & REC. CENTER	\$64,827.79
		08/02/2023	20428543	ICE MACHINE POWER HEAD REPAIR-FIRE STATION 48	
		08/02/2023	20430417	STANDALONE COMMERCIAL FREEZER COMPRESSOR REPAIR-FIRE STATION 6	
		08/02/2023	20430894	TS AC UNIT REPAIR-CITY HALL	
		08/02/2023	20430895	AC-8 CYCLING OFF-CONFERENCE & REC. CENTER	
		08/02/2023	94490	ANIMAL SHELTER DUCT CLEANING & AHU FILTER REPLACEMENT	
Remit to: PASADENA, CA					<u>FYTD:</u> \$111,902.39
ALL AMERICAN ASPHALT, INC.	245966	08/09/2023	201565_RET	801 0073 JUAN BAUTISTA TRAIL ATP 2	\$146,094.44
		08/09/2023	34571_12	801 0096 CITYWIDE PVT REHAB PROG (FY 21-26)	
Remit to: CORONA, CA					<u>FYTD:</u> \$6,456,819.78
CHARLES ABBOTT ASSOCIATES, INC	37971	08/02/2023	65961	ENGINEERING SVCS-JUNE 2023	\$40,147.00
		08/02/2023	65963	PLAN CHECK SVCS-HIGHLAND FAIRVIEW/WLC-JUNE 2023	
		08/02/2023	65964	PLAN CHECK SVCS-NPDES-JUNE 2023	
		08/02/2023	65965	PLAN CHECK SVCS-WQMP REVIEW-JUNE 2023	
Remit to: MISSION VIEJO, CA					<u>FYTD:</u> \$86,200.75

Attachment: August2023PaymentRegisterSR (6410 : AUGUST PAYMENT REGISTER 2023)



City of Moreno Valley
Payment Register
For Period 8/1/2023 through 8/31/2023

CHECKS IN THE AMOUNT OF \$25,000 OR GREATER

<u>Vendor Name</u>	<u>Check/EFT Number</u>	<u>Payment Date</u>	<u>Inv Number</u>	<u>Invoice Description</u>	<u>Payment Amount</u>
CONSTELLATION ENERGY GENERATION, LLC	38097	08/16/2023	899905	POWER PURCHASE-7/01-7/31/23-MVU	\$950,957.60
Remit to: BALTIMORE, MD					<u>FYTD:</u> \$1,727,737.12
COUNTY OF RIVERSIDE FIRE DEPT	37975	08/02/2023	235054	FIRE SERVICES CONTRACT-3RD QTR (FPARC-MV, 235054,22/23,Q3)	\$5,667,564.76
Remit to: PERRIS, CA					<u>FYTD:</u> \$5,667,564.76
COUNTY OF RIVERSIDE SHERIFF	37976	08/02/2023	SH0000043190	CONTRACT LAW ENFORCEMENT BILLING #10 (03/09/23-04/05/23)	\$3,417,583.77
	38040	08/09/2023	SH0000043657	CONTRACT LAW ENFORCEMENT BILLING #11 (04/06/23-05/03/23)	\$10,943,276.07
		08/09/2023	SH0000043695	CONTRACT LAW ENFORCEMENT BILLING #12 (05/04/23-05/31/23)	
		08/09/2023	SH0000043770	CONTRACT LAW ENFORCEMENT BILLING #13 (06/01/23-06/30/23)	
Remit to: RIVERSIDE, CA					<u>FYTD:</u> \$15,063,068.40
D.R. HORTON INC.	245953	08/02/2023	PROJ. PEN20-0075	REFUND EROSION CTRL SECURITY DEPOSIT-PROJ# PEN20-0075 (TR 31590)	\$37,525.00
Remit to: CORONA, CA					<u>FYTD:</u> \$37,525.00

Attachment: August2023PaymentRegisterSR (6410 : AUGUST PAYMENT REGISTER 2023)



City of Moreno Valley
Payment Register
For Period 8/1/2023 through 8/31/2023

CHECKS IN THE AMOUNT OF \$25,000 OR GREATER

Vendor Name	Check/EFT Number	Payment Date	Inv Number	Invoice Description	Payment Amount
DATA TICKET, INC.	38150	08/23/2023	155017	PARKING CITATION PROCESSING-CODE-JULY 2023	\$30,829.11
		08/23/2023	155017HH	PARKING HANDHELD DEVICES-REPLACEMENT-CODE-JULY 2023	
		08/23/2023	155269	ADMIN CITATION PROCESSING-ANIMAL SVC-JULY 2023	
		08/23/2023	155270	ADMIN CITATION PROCESSING-CODE-JULY 2023	
		08/23/2023	155270TPC	ADMIN CITATION PROCESSING-3RD PARTY COLLECTIONS-CODE-JULY 2023	
		08/23/2023	155271	ADMIN CITATION PROCESSING-PD-JULY 2023	
Remit to: IRVINE, CA					FYTD: \$72,909.18
DECKERS OUTDOOR CORPORATION	38042	08/09/2023	QTR ENDING MAR23	SALES TAX PAYMENT PER OPERATING COVENANT AGREEMENT	\$139,258.50
Remit to: GOLETA, CA					FYTD: \$139,258.50
EASTERN MUNICIPAL WATER DISTRICT	245933	08/02/2023	JUL-23 8/2/23	WATER CHARGES	\$80,364.38
		08/02/2023	JUN-23 8/2/23	WATER CHARGES	
	246098	08/23/2023	AUG-23 8/23/23	WATER CHARGES	\$269,273.12
		08/23/2023	JUL-23 8/23/23	WATER CHARGES	
Remit to: LOS ANGELES, CA					FYTD: \$506,232.78

Attachment: August2023PaymentRegisterSR (6410 : AUGUST PAYMENT REGISTER 2023)



City of Moreno Valley
Payment Register
For Period 8/1/2023 through 8/31/2023

CHECKS IN THE AMOUNT OF \$25,000 OR GREATER

<u>Vendor Name</u>	<u>Check/EFT Number</u>	<u>Payment Date</u>	<u>Inv Number</u>	<u>Invoice Description</u>	<u>Payment Amount</u>
ENCO UTILITY SERVICES MORENO VALLEY LLC	38103	08/16/2023	INV58543	METER FEES-CHASE CACTUS	\$718,487.89
		08/16/2023	INV58544	TEMP METER FEES-POWER PLUS/ALLIANCE RES & KB HOMES	
		08/16/2023	INV61026	SOLAR SYSTEM INSPECTION	
		08/16/2023	INV61027	SOLAR SYSTEM INSPECTION	
		08/16/2023	INV61028	SOLAR SYSTEM INSPECTION	
		08/16/2023	INV61029	SOLAR SYSTEM INSPECTION	
		08/16/2023	INV61030	SOLAR SYSTEM INSPECTION	
		08/16/2023	INV61108	DISTRIBUTION CHARGES - 07/01/23 TO 07/31/23 - MVU	

Attachment: August2023PaymentRegisterSR (6410 : AUGUST PAYMENT REGISTER 2023)



City of Moreno Valley
Payment Register
For Period 8/1/2023 through 8/31/2023

CHECKS IN THE AMOUNT OF \$25,000 OR GREATER

<u>Vendor Name</u>	<u>Check/EFT Number</u>	<u>Payment Date</u>	<u>Inv Number</u>	<u>Invoice Description</u>	<u>Payment Amount</u>
ENCO UTILITY SERVICES MORENO VALLEY LLC	38153	08/23/2023	40-408B-04	WA# 40-408B-RANCHO BELAGO PH 2	\$56,223.06
		08/23/2023	40-455B-09	WA# 40-455B-MORENO VALLEY ELEMENTARY SCHOOL	
		08/23/2023	40-461B-04	WA# 40-461B-MORENO VALLEY MAJESTIC-8 SFR	
		08/23/2023	40-474B-10	WA# 40-474B-KB HOMES - MOOTHART 80 HOMES	
		08/23/2023	40-484B-01	WA# 40-484B-IRIS PARK 81 UNITS-TR 37909	
		08/23/2023	40-501-2307	MVU CONTRACT 40-501-ACQUIRED SCE STREETLIGHTS MAINTENANCE	
		08/23/2023	40-505B-04	WA# 40-505B-TRACT 37725 - 64 SF HOMES	
		08/23/2023	40-506B-02	WA# 40-506B-ROCAS GRANDES APARTMENTS	
		08/23/2023	40-507-05	WA# 40-507-SUBSTATION IT SUPPORT	
		08/23/2023	40-508-14	WA# 40-508-CYBER SECURITY MONITORING	
		08/23/2023	40-512B-02	WA# 40-512B-QUICK QUACK CAR WASH	
		08/23/2023	40-514A-12	WA# 40-514A-SKYLER PLACE - TR 38123 177 SFR	
		08/23/2023	40-522A-09	WA# 40-522A-EDWIN 12KV AND MARCH 12KV CIRCUIT TIE	
		08/23/2023	40-523B-07	WA# 40-523B-MV MARKETPLACE	
		08/23/2023	40-534-03	WA# 40-534-ITRON FIELD HARDWARE INSTALLATION - COMMISSIONING PH 2	
		08/23/2023	40-535A-04	WA# 40-535A-STELLA PLACE 205 SFR	
		08/23/2023	40-540A-04	WA# 40-540A-CRYSTAL COVE APARTMENTS 200 UNITS	
		08/23/2023	40-544A-03	WA# 40-544A-MORENO VALLEY BUSINESS CENTER 1	
		08/23/2023	40-552A-02	WA# 40-552A-MORENO VALLEY BUSINESS CENTER 4	

Remit to: ANAHEIM, CA FYTD: \$1,434,858.41

ESCRIBE SOFTWARE LTD 246150 08/30/2023 US-1320 PREMIUM BUNDLE-7/1/23 TO 6/30/24-TECH SVCS \$52,510.00

Remit to: INDIANAPOLIS, IN FYTD: \$52,510.00

Attachment: August2023PaymentRegisterSR (6410 : AUGUST PAYMENT REGISTER 2023)



City of Moreno Valley
Payment Register
For Period 8/1/2023 through 8/31/2023

CHECKS IN THE AMOUNT OF \$25,000 OR GREATER

<u>Vendor Name</u>	<u>Check/EFT Number</u>	<u>Payment Date</u>	<u>Inv Number</u>	<u>Invoice Description</u>	<u>Payment Amount</u>
FALCON ENGINEERING SERVICES, INC.	38206	08/30/2023	2023-7	801 0021 SR60/MORENO BEACH PH 2	\$107,710.63
Remit to: CORONA, CA					FYTD: \$213,369.03
FLOCK GROUP INC. DBA FLOCK SAFETY	38155	08/23/2023	INV-20364	IMPLEMENTATION FEES-TECH SVCS	\$495,781.51
		08/23/2023	INV-20690	ADDITIONAL TRIP-TECH SVCS	
Remit to: ATLANTA, GA					FYTD: \$496,881.51
FRANCE PUBLICATIONS, INC. DBA FRANCE MEDIA, INC	38104	08/16/2023	2023ci	MISC FULL PAGE/TABLOID PAGE-EDD	\$38,140.00
		08/16/2023	2537	MISC REGIST & SPONSORSHIPS-EDD	
Remit to: ATLANTA, GA					FYTD: \$41,590.00
FRONTIER COMMUNICATIONS	245935	08/02/2023	051590-5 JUL23	COMMUNICATION SVCS-JULY 2023-TECH SVCS	\$25,469.60
Remit to: CINCINNATI, OH					FYTD: \$27,882.87
G3 QUALITY INC	38052	08/09/2023	13969	801 0090 CITYWIDE PVT REHAB PROG FY22/23	\$76,102.50
		08/09/2023	14112	801 0090 CITYWIDE PVT REHAB PROG FY22/23	
Remit to: CERRITOS, CA					FYTD: \$80,042.25

Attachment: August2023PaymentRegisterSR (6410 : AUGUST PAYMENT REGISTER 2023)



**City of Moreno Valley
Payment Register
For Period 8/1/2023 through 8/31/2023**

CHECKS IN THE AMOUNT OF \$25,000 OR GREATER

<u>Vendor Name</u>	<u>Check/EFT Number</u>	<u>Payment Date</u>	<u>Inv Number</u>	<u>Invoice Description</u>	<u>Payment Amount</u>
GREENTECH LANDSCAPE, INC.	38108	08/16/2023	56149	SD LANDSCAPE ADDITIONAL WORK (SOUTH) - ZONE E-8	\$33,561.33
		08/16/2023	56163	SD LANDSCAPE ADDITIONAL WORK (SOUTH) - ZONE 03, 04, 06, 07, E-8	
		08/16/2023	56164	SD LANDSCAPE ADDITIONAL WORK (MORENO) MARCH-JUNE ZONE M & S	
	38212	08/16/2023	56166	SD LANDSCAPE ADDITIONAL WORK (VALLEY) ZONE D - MARCH-JUNE	\$47,512.10
		08/30/2023	56216	SD LANDSCAPE BASE (SOUTH) JULY	
		08/30/2023	56218	SD LANDSCAPE BASE (VALLEY) JULY	
Remit to: LOS ANGELES, CA					FYTD: \$359,479.17
GRID ALTERNATIVES	38053	08/09/2023	INV 6.1 ARI09979	SOLAR ENERGY ASSISTANCE PROGRAM-MAY 2023	\$29,254.11
		08/09/2023	INV 7 ARI0010116	SOLAR ENERGY ASSISTANCE PROGRAM-JUNE 2023	
Remit to: RIVERSIDE, CA					FYTD: \$33,670.45
HITACHI VANTARA LLC	38156	08/23/2023	5158118	YEAR 5 OF 6 ANNUAL MAINTENANCE-TECH SVCS	\$203,797.32
Remit to: SANTA CLARA, CA					FYTD: \$227,400.58
HR GREEN PACIFIC INC.	37984	08/02/2023	162076	ON-CALL TRAFFIC ENGINEERING SERVICES-MARCH 2023	\$31,973.50
		08/02/2023	163780	ON-CALL TRAFFIC ENGINEERING SERVICES-MAY 2023	
		08/02/2023	164496	ON-CALL TRAFFIC ENGINEERING SERVICES-JUNE 2023	
Remit to: DES MOINES, IA					FYTD: \$31,973.50
ICF INCORPORATED, LLC DBA ICF CONSULTING, INC.	38055	08/09/2023	2023-167246	810 0021 ELECTRIC VEHICLE CHARGING INFRASTRUCTURE MASTER	\$27,895.14
Remit to: RESTON, VA					FYTD: \$27,895.14

Attachment: August2023PaymentRegisterSR (6410 : AUGUST PAYMENT REGISTER 2023)



**City of Moreno Valley
Payment Register
For Period 8/1/2023 through 8/31/2023**

CHECKS IN THE AMOUNT OF \$25,000 OR GREATER

<u>Vendor Name</u>	<u>Check/EFT Number</u>	<u>Payment Date</u>	<u>Inv Number</u>	<u>Invoice Description</u>	<u>Payment Amount</u>
KB HOME CALIFORNIA LLC	245961	08/02/2023	PROJ. PA12-0005	REFUND EROSION CTRL SECURITY DEPOSIT-PROJ.# PA12-0005 (TR 36436)	\$54,412.50
Remit to: WILDOMAR, CA					<u>FYTD:</u> \$54,412.50
KOURY ENGINEERING & TESTING, INC.	38057	08/09/2023	955500	801 0097 CITYWIDE PAVEMENT REHABILITATION PGM (FY26/27-30/31)	\$28,400.00
Remit to: CHINO, CA					<u>FYTD:</u> \$50,290.00
KTU+A	37989	08/02/2023	35046	PARKS MASTER PLAN PROJECT SERVICES-MAY 2023	\$36,458.20
		08/02/2023	35115	PARKS MASTER PLAN PROJECT SERVICES-JUNE 2023	
Remit to: SAN DIEGO, CA					<u>FYTD:</u> \$36,458.20
LAKE ELSINORE & SAN JACINTO WATERSHEDS AUTHORITY	246153	08/30/2023	TMDL 2024-06	TASK FORCE STAKEHOLDER CONTRIBUTION-FY 23/24	\$73,550.00
Remit to: RIVERSIDE, CA					<u>FYTD:</u> \$73,550.00
LIBRARY SYSTEMS & SERVICES, LLC	38114	08/16/2023	INV7876	LIBRARY CONTRACT SVCS & MATERIALS-MAIN/MALL/IRIS-JULY 2023	\$418,588.50
		08/16/2023	INV8033	LIBRARY CONTRACT SVCS & MATERIALS-MAIN/MALL/IRIS-AUGUST 2023	
		08/16/2023	INV8124	LIBRARY CONTRACT SVCS-PMT SVCS & KIOSK ADMIN	
Remit to: ROCKVILLE, MD					<u>FYTD:</u> \$638,884.35

Attachment: August2023PaymentRegisterSR (6410 : AUGUST PAYMENT REGISTER 2023)



City of Moreno Valley
Payment Register
For Period 8/1/2023 through 8/31/2023

CHECKS IN THE AMOUNT OF \$25,000 OR GREATER

<u>Vendor Name</u>	<u>Check/EFT Number</u>	<u>Payment Date</u>	<u>Inv Number</u>	<u>Invoice Description</u>	<u>Payment Amount</u>
M. BREY ELECTRIC, INC.	37993	08/02/2023	8526	GENERAL REPAIRS-RED MAPLE (VAL VERDE) CHILD CARE	\$38,405.00
	38116	08/16/2023	8298	INSTALL (12)40 WATT LED SQUARE CANOPY LIGHTS-PUBLIC SAFETY BLDG.	\$74,779.04
		08/16/2023	8314	PERMIT FEES-CONFERENCE & REC CENTER	
		08/16/2023	8385	GVBR BLINDS ASSESSMENT SERVICE CALL-CONFERENCE & REC CENTER	
		08/16/2023	8403	EVIDENCE ROOM & IN-TAKE ROLL UP DOOR REPAIRS-PUBLIC SAFETY BLDG	
		08/16/2023	8404	REAR ROLLUP DOOR INSTALL 10K REGISTER ON SAFETY EDGE-PSB	
		08/16/2023	8405	DR#1 LONG RANGE ANTENNA & RADIO RECEIVER/DR#2 5L304 INSTALL-PSB	
		08/16/2023	8406	NEW HOLD DOWN CLIP FOR NW REAR DOOR-FIRE STATION 58	
		08/16/2023	8408	MOTOR OPERATOR/PHOTO EYE W/ REFLECTOR INSTALL -ROLL UP DOOR A	
		08/16/2023	8504	NEW SAFETY EDGE INSTALL-FIRE STATION 6	
		08/16/2023	8505	ROLLUP DOOR #2 TROUBLESHOOT-FIRE STATION 6	
		08/16/2023	8506	PM DOOR SERVICE-FIRE STATIONS 2, 6, 48, 58, 91 & 99	
		08/16/2023	8511	EAST BAY DOOR #2 TROUBLESHOOT & REPAIR -FIRE STATION 58	
		08/16/2023	8516	PLUMBING VALVE REPAIRS-PUBLIC SAFETY BLDG.	
		08/16/2023	8517	NEW FAUCET & GRID STYLE STRAINER INSTALL-PUBLIC SAFETY BLDG.	
		08/16/2023	8518	HYDROJETTER PLUMBING REPAIR-PUBLIC SAFETY BLDG.	
		08/16/2023	8519	NEW P-TRAP & FLOOR DRAIN INSTALL-PUBLIC SAFETY BLDG.	
	08/16/2023	8521	EMPLOYEE PARKING LOT GATE SAFETY LOOP REPAIR-FIRE STATION 91		
	08/16/2023	8588	PERRIS GATE OPERATOR REPAIR-CITY YARD		

Attachment: August2023PaymentRegisterSR (6410 : AUGUST PAYMENT REGISTER 2023)



**City of Moreno Valley
Payment Register
For Period 8/1/2023 through 8/31/2023**

CHECKS IN THE AMOUNT OF \$25,000 OR GREATER

<u>Vendor Name</u>	<u>Check/EFT Number</u>	<u>Payment Date</u>	<u>Inv Number</u>	<u>Invoice Description</u>	<u>Payment Amount</u>
M. BREY ELECTRIC, INC.	38160	08/23/2023	8610	CLEAN OUT RISER INSTALL-CITY HALL	\$140,579.69
		08/23/2023	8617	NEW ELECTRIC GVBR SHADES INSTALL-CONFERENCE & REC CENTER	
		08/23/2023	8645	CONFERENCE ROOM GLASS WINDOW REPAIR-CITY YARD SANTIAGO	
		08/23/2023	8660	LOCK REPAIR-TOWNGATE MEMORIAL PARK	
		08/23/2023	8737	REAR APPARATUS BAY DOOR REPLACEMENT-FIRE STATION 48	
		08/23/2023	8738	FRONT APPARATUS BAY DOOR REPLACEMENT-FIRE STATION 48	
		08/23/2023	8739	2 SAFETY LOOP/1 EXIT LOOP INSTALL-PERRIS GATE-CITY YARD	
		08/23/2023	8743	BASKETBALL COURT WELDING-SANTIAGO PARK	
		08/23/2023	8744	FENCING/GATE REPAIRS-SUNNYMEAD PARK	
Remit to: BEAUMONT, CA					<u>FYTD:</u> \$341,714.73
MERCHANTS BUILDING MAINTENANCE, LLC.	38060	08/09/2023	739434	DAY PORTER SERVICES FOR ENHANCED COVID-19 CLEANING-MAY 2023	\$77,912.30
		08/09/2023	745838	DAY PORTER SERVICES FOR ENHANCED COVID-19 CLEANING-JUN. 2023	
		08/09/2023	745839	CITY FACILITIES ROUTINE JANITORIAL SERVICES - JUNE 2023	
Remit to: MONTEREY PARK, CA					<u>FYTD:</u> \$92,848.19
MOSS BROS. CHEVROLET	246023	08/16/2023	DEAL #61438	CHEVY BOLT EV PURCHASE - VIN 1G1FW6S00P4168936	\$38,651.14
Remit to: MORENO VALLEY, CA					<u>FYTD:</u> \$38,651.14
ORACLE AMERICA	38166	08/23/2023	100811280	ORACLE UTILITIES CUSTOMER CLOUD SERVICES	\$70,371.95
Remit to: REDWOOD SHORES, CA					<u>FYTD:</u> \$70,371.95

Attachment: August2023PaymentRegisterSR (6410 : AUGUST PAYMENT REGISTER 2023)



City of Moreno Valley
Payment Register
For Period 8/1/2023 through 8/31/2023

CHECKS IN THE AMOUNT OF \$25,000 OR GREATER

Vendor Name	Check/EFT Number	Payment Date	Inv Number	Invoice Description	Payment Amount
PERMA	38065	08/09/2023	INV90	FY23/24 INSURANCE PROGRAM PREMIUMS & LIABILITY TRUST ACCT DEPOS.	\$2,714,826.00
Remit to: PALM DESERT, CA					FYTD: \$2,714,826.00
PUB CONSTRUCTION, INC.	38000	08/02/2023	304886	801 0086 JUAN BAUTISTA TRAIL ATP 4	\$211,793.95
	38066	08/09/2023	304920	801 0086 JUAN BAUTISTA TRAIL ATP 4	\$346,420.27
Remit to: DIAMOND BAR, CA					FYTD: \$558,214.22
PUBLIC RISK, INNOVATION, SOLUTIONS, AND MANAGEMENT	38067	08/09/2023	24100140	EXCESS WORKERS' COMPENSATION FY 23/24	\$255,295.00
Remit to: FOLSOM, CA					FYTD: \$255,295.00
R J NOBLE CO., INC.	38068	08/09/2023	229467	801 0097 CITYWIDE PVT REHAB PROG (FY26-31)	\$936,325.27
		08/09/2023	229468	801 0089 CITYWIDE PVT REHAB FY 21/22	
Remit to: ORANGE, CA					FYTD: \$4,164,194.94
RE ASTORIA 2 LLC	38069	08/09/2023	2023_7_RE AST 2	RENEWABLE ENERGY-MV UTILITY-JUNE 2023	\$39,880.08
Remit to: SAN FRANCISCO, CA					FYTD: \$39,880.08
RING BENDER LLP	38123	08/16/2023	11635	LEGAL SERVICES RE: MV 13-19	\$30,112.01
		08/16/2023	11705	LEGAL SERVICES RE: MV 13-19	
		08/16/2023	11737	LEGAL SERVICES RE: MV 13-19	
Remit to: PORTLAND, OR					FYTD: \$30,112.01

Attachment: August2023PaymentRegisterSR (6410 : AUGUST PAYMENT REGISTER 2023)



City of Moreno Valley
Payment Register
For Period 8/1/2023 through 8/31/2023

CHECKS IN THE AMOUNT OF \$25,000 OR GREATER

<u>Vendor Name</u>	<u>Check/EFT Number</u>	<u>Payment Date</u>	<u>Inv Number</u>	<u>Invoice Description</u>	<u>Payment Amount</u>
RIVERSIDE COUNTY SHERIFF'S DEPT.	246016	08/16/2023	SH0000043789	CAL-ID MEMBER ASSESSMENT 7/1/23-6/30/24	\$209,407.00
Remit to: RIVERSIDE, CA					<u>FYTD:</u> \$209,407.00

Attachment: August2023PaymentRegisterSR (6410 : AUGUST PAYMENT REGISTER 2023)



City of Moreno Valley
Payment Register
For Period 8/1/2023 through 8/31/2023

CHECKS IN THE AMOUNT OF \$25,000 OR GREATER

<u>Vendor Name</u>	<u>Check/EFT Number</u>	<u>Payment Date</u>	<u>Inv Number</u>	<u>Invoice Description</u>	<u>Payment Amount</u>
SC COMMERCIAL LLC DBA SC FUELS	38003	08/02/2023	2406564-IN	FUEL FOR CITY VEHICLES & EQUIPMENT	\$53,192.45
		08/02/2023	2408639-IN	FUEL FOR CITY VEHICLES & EQUIPMENT	
		08/02/2023	2410503-IN	FUEL FOR CITY VEHICLES & EQUIPMENT	
		08/02/2023	2413871-IN	FUEL FOR CITY VEHICLES & EQUIPMENT	
		08/02/2023	2416926-IN	FUEL FOR CITY VEHICLES & EQUIPMENT	
		08/02/2023	2418913-IN	FUEL FOR CITY VEHICLES & EQUIPMENT	
		08/02/2023	2419942-IN	FUEL FOR CITY VEHICLES & EQUIPMENT	
		08/02/2023	2420981-IN	FUEL FOR CITY VEHICLES & EQUIPMENT	
		08/02/2023	2422986-IN	FUEL FOR CITY VEHICLES & EQUIPMENT	
		08/02/2023	2425545-IN	FUEL FOR CITY VEHICLES & EQUIPMENT	
		08/02/2023	2426445-IN	FUEL FOR CITY VEHICLES & EQUIPMENT	
		08/02/2023	2428754-IN	FUEL FOR CITY VEHICLES & EQUIPMENT	
		08/02/2023	2429268-IN	FUEL FOR CITY VEHICLES & EQUIPMENT	
		08/02/2023	2430997-IN	FUEL FOR CITY VEHICLES & EQUIPMENT	
		08/02/2023	415914R-DM	FUEL FOR CITY VEHICLES & EQUIPMENT	

Attachment: August2023PaymentRegisterSR (6410 : AUGUST PAYMENT REGISTER 2023)



City of Moreno Valley
Payment Register
For Period 8/1/2023 through 8/31/2023

CHECKS IN THE AMOUNT OF \$25,000 OR GREATER

<u>Vendor Name</u>	<u>Check/EFT Number</u>	<u>Payment Date</u>	<u>Inv Number</u>	<u>Invoice Description</u>	<u>Payment Amount</u>
SC COMMERCIAL LLC DBA SC FUELS	38176	08/23/2023	2433997-IN	FUEL FOR CITY VEHICLES & EQUIPMENT	\$51,846.80
		08/23/2023	2435286-IN	FUEL FOR CITY VEHICLES & EQUIPMENT	
		08/23/2023	2435449-IN	FUEL FOR CITY VEHICLES & EQUIPMENT	
		08/23/2023	2437103-IN	FUEL FOR CITY VEHICLES & EQUIPMENT	
		08/23/2023	2439168-IN	FUEL FOR CITY VEHICLES & EQUIPMENT	
		08/23/2023	2440895-IN	FUEL FOR CITY VEHICLES & EQUIPMENT	
		08/23/2023	2441422-IN	FUEL FOR CITY VEHICLES & EQUIPMENT	
		08/23/2023	2443589-IN	FUEL FOR CITY VEHICLES & EQUIPMENT	
		08/23/2023	2445847-IN	FUEL FOR CITY VEHICLES & EQUIPMENT	
		08/23/2023	2447433-IN	FUEL FOR CITY VEHICLES & EQUIPMENT	
		08/23/2023	2449386-IN	FUEL FOR CITY VEHICLES & EQUIPMENT	
		08/23/2023	2449830-IN	FUEL FOR CITY VEHICLES & EQUIPMENT	
		08/23/2023	2451139-IN	FUEL FOR CITY VEHICLES & EQUIPMENT	
		08/23/2023	2452643-IN	FUEL FOR CITY VEHICLES & EQUIPMENT	
Remit to: ORANGE, CA					<u>FYTD:</u> \$137,186.73
SKANSKA USA CIVIL WEST CALIFORNIA DISTRICT, INC.	38075	08/09/2023	9	801 0021 SR60/MORENO BEACH PH 2	\$1,194,849.57
Remit to: RIVERSIDE, CA					<u>FYTD:</u> \$2,935,507.71

Attachment: August2023PaymentRegisterSR (6410 : AUGUST PAYMENT REGISTER 2023)



City of Moreno Valley
Payment Register
For Period 8/1/2023 through 8/31/2023

CHECKS IN THE AMOUNT OF \$25,000 OR GREATER

Vendor Name	Check/EFT Number	Payment Date	Inv Number	Invoice Description	Payment Amount
SOUTHERN CALIFORNIA EDISON	245942	08/02/2023	7501578903	WDAT CHARGES-MVU/17160 KITCHING ST. SUBSTATION-JUN. 2023	\$63,604.57
		08/02/2023	7501578904	WDAT CHARGES-MVU/24417 NANDINA AVE. SUBSTATION-JUN. 2023	
		08/02/2023	7501578921	WDAT CHARGES-MVU/GRAHAM ST.-JUN. 2023	
		08/02/2023	7501578922	WDAT CHARGES-MVU/FREDERICK AVE.-JUN. 2023	
		08/02/2023	7501578923	WDAT CHARGES-MVU/SUBSTATION 115KV INTERCONNECTION-JUN. 2023	
	246107	08/23/2023	282492235/JUL-23	ELECTRICITY-FERC CHARGES/MVU	\$142,188.37
		08/23/2023	355556776/JUL-23	ELECTRICITY CHARGES FOR ACQUIRED STREETLIGHTS	
		08/23/2023	431591238/JUL-23	ELECTRICITY CHARGES FOR ACQUIRED STREETLIGHTS	
		08/23/2023	433869021/JUL-23	ELECTRICITY CHARGES FOR ADDED STREETLIGHTS	
		08/23/2023	435293103/JUL-23	ELECTRICITY CHARGES FOR ADDED STREETLIGHTS	
		08/23/2023	498683714/JUL-23	ELECTRICITY CHARGES FOR ACQUIRED STREETLIGHTS	
		08/23/2023	559238386/JUL-23	IFA & DISTRIBUTION UPGRADE CHARGES-KITCHING SUBSTATION	
		08/23/2023	570511709/JUL-23	IFA CHARGES-SUBSTATION	
08/23/2023	JUL-23 8/23/23	ELECTRICITY CHARGES			
Remit to: ROSEMEAD, CA					FYTD: \$400,617.68
STEVEN B. QUINTANILLA A PROFESSIONAL CORPORATION	38006	08/02/2023	APRIL 2023	LEGAL SERVICES 4/1 TO 4/30/23	\$111,212.95
		08/02/2023	JUN-23/MILLER	SPECIAL COUNSEL LITIGATION SVCS-MILLER STARR REG. 06/01-06/30/23	
	38128	08/16/2023	JUNE 2023	LEGAL SERVICES 6/1 TO 6/30/23	\$202,938.70
		08/16/2023	MAY 2023	LEGAL SERVICES 5/1 TO 5/31/23	
Remit to: PALM SPRINGS, CA					FYTD: \$314,991.65

Attachment: August2023PaymentRegisterSR (6410 : AUGUST PAYMENT REGISTER 2023)



City of Moreno Valley
Payment Register
For Period 8/1/2023 through 8/31/2023

CHECKS IN THE AMOUNT OF \$25,000 OR GREATER

<u>Vendor Name</u>	<u>Check/EFT Number</u>	<u>Payment Date</u>	<u>Inv Number</u>	<u>Invoice Description</u>	<u>Payment Amount</u>
SYNERGY COMPANIES	38008	08/02/2023	MVU RES DI 06-23	ENERGY AUDITS & INSTALLATION OF ENERGY EFFICIENT MEASURES-JUN23	\$196,193.24
Remit to: HAYWARD, CA					<u>FYTD:</u> \$196,193.24
TENASKA ENERGY, INC	38009	08/02/2023	MOREN00202307210	ELECTRICITY POWER PURCHASE-MV UTILITY	\$264,027.44
	38242	08/30/2023	MOREN00202308210	ELECTRICITY POWER PURCHASE-MV UTILITY	\$642,990.31
Remit to: ARLINGTON, TX					<u>FYTD:</u> \$1,228,583.84
THE ADVANTAGE GROUP/ FLEX ADVANTAGE	38078	08/09/2023	202307	JULY 2023 RETIREE MEDICAL BENEFIT BILLING	\$53,182.21
	38089	08/09/2023	202308	AUGUST 2023 RETIREE MEDICAL BENEFIT BILLING	\$44,530.11
Remit to: TEMECULA, CA					<u>FYTD:</u> \$100,848.72
THE SALVATION ARMY	38073	08/09/2023	16185	FY 23/24 HOMELESS TO WORK PROGRAM	\$200,000.00
		08/09/2023	21532	FY 23/24 HOMELESS ASSISTANCE PROGRAM	
Remit to: RIVERSIDE, CA					<u>FYTD:</u> \$222,545.98
THINK TOGETHER, INC	38180	08/23/2023	111-24-01	ASES EXPANDED LEARNING PROGRAM MGMT. SERVICES-INSTALLMENT #10	\$695,389.41
		08/23/2023	121-24-01S	21ST CCLC - SUMMER PROGRAM EDGEMONT ELEMENTARY 23/24	
Remit to: SANTA ANA, CA					<u>FYTD:</u> \$715,812.70

Attachment: August2023PaymentRegisterSR (6410 : AUGUST PAYMENT REGISTER 2023)



City of Moreno Valley
Payment Register
For Period 8/1/2023 through 8/31/2023

CHECKS IN THE AMOUNT OF \$25,000 OR GREATER

Vendor Name	Check/EFT Number	Payment Date	Inv Number	Invoice Description	Payment Amount
TKE ENGINEERING INC	245947	08/02/2023	2023-494	801 0096 CITYWIDE PVT REHAB PROG (FY 21-26)	\$113,380.00
		08/02/2023	2023-495	801 0086 JUAN BAUTISTA DE ANZA MULTI USE TRAIL - ATP 4	
		08/02/2023	2023-535	801 0096 CITYWIDE PVT REHAB PROG (FY 21-26)	
		08/02/2023	2023-536	801 0086 JUAN BAUTISTA DE ANZA MULTI USE TRAIL - ATP 4	
Remit to: RIVERSIDE, CA					FYTD: \$114,767.50
U.S. BANK/CALCARDS	38014	08/02/2023	07-27-23	JULY 2023 CALCARD ACTIVITY	\$310,262.00
		38246	08/30/2023	08-28-23	AUGUST 2023 CALCARD ACTIVITY
Remit to: ST. LOUIS, MO					FYTD: \$942,023.69
VISTA PAINT CORPORATION	38083	08/09/2023	2023-078455-00	ON-LINE TRAFFIC PAINT, GLASS BEADS, AND OTHER SUPPLIES	\$41,961.47
Remit to: FULLERTON, CA					FYTD: \$42,510.32
WILLDAN ENGINEERING	38134	08/16/2023	002-28996	PLAN CHECK & INSPECTION SERVICES FOR BLDG. & SAFETY DEPT.- MAY23	\$227,894.96
		08/16/2023	002-29437	PLAN CHECK & INSPECTION SERVICES FOR BLDG. & SAFETY DEPT.- JUN23	
Remit to: ANAHEIM, CA					FYTD: \$397,873.22
WRCRCA	38087	08/09/2023	JUN-2023 MSHCP	MSHCP FEES COLLECTED FOR JUN. 2023-RESIDENTIAL & COMMERCIAL/IND.	\$554,979.22
Remit to: RIVERSIDE, CA					FYTD: \$625,123.04
TOTAL AMOUNTS OF \$25,000 OR GREATER					\$35,010,685.12

Attachment: August2023PaymentRegisterSR (6410 : AUGUST PAYMENT REGISTER 2023)



City of Moreno Valley
Payment Register
For Period 8/1/2023 through 8/31/2023

CHECKS UNDER \$25,000

Vendor Name	Check/EFT Number	Payment Date	Inv Number	Invoice Description	Payment Amount
4IMPRINT	38093	08/16/2023	11114375A	SORBET POCKET NOTEBOOKS-MVU	\$663.30
Remit to: OSHKOSH, WI					FYTD: \$663.30
ACCELA, INC.	38023	08/09/2023	AC22-29-175-0174	REGISTRATION FEE FOR ACCELARATE 2023-Y BISHOP	\$2,270.50
		08/09/2023	AC22-29-266-0265	REGISTRATION FEE FOR ACCELARATE 2023-J LANKHORST	
Remit to: CHICAGO, IL					FYTD: \$2,270.50
ACCO ENGINEERED SYSTEMS, INC	38024	08/09/2023	20401816	HVAC PREV MAINTENANCE-EMERGENCY OPS CENTER	\$9,000.00
		08/09/2023	20407308	AC-1 VFD REPLACEMENT-CITY HALL	
	38094	08/16/2023	20401812	HVAC PREV MAINTENANCE-ANNEX 1	\$10,448.49
		08/16/2023	20410056	REPLACE LEAKY BALL VALVE-EMERGENCY OPERATIONS CENTER	
		08/16/2023	20410076	AC-1 SUPPLY FAN FAILURE-CITY HALL	
		08/16/2023	20430648	AC-1 CRANK CASE HEATER-PUBLIC SAFETY BLDG.	
		08/16/2023	20432578	ISSUE WITH AC 2-FIRE STATION 6	
		08/16/2023	20432658	ICE MACHINE TROUBLESHOOT-FIRE STATION 48	
		08/16/2023	20432659	PUPPY COOLER DRAIN LINE HEATER REPLACEMENT-ANIMAL SHELTER	
		08/16/2023	20433861	PUPPY COOLER NOT RUNNING-ANIMAL SHELTER	
	38139	08/23/2023	20439491	HVAC PREV MAINTENANCE-EMERGENCY OPS CENTER	\$1,798.11
		08/23/2023	20444774	WATER LEAK IN SERVER ROOM-CITY YARD SANTIAGO	
		08/23/2023	20444780	ICE MACHINE REPAIR-FIRE STATION 58	
	38191	08/30/2023	20439487	HVAC PREV MAINTENANCE-ANNEX 1	\$3,819.00
		08/30/2023	20439488	HVAC PREV MAINTENANCE-CITY HALL	
Remit to: PASADENA, CA					FYTD: \$111,902.39
ACOSTA, DENISE	246025	08/16/2023	2003474.047	ACCOUNT CREDIT REFUND	\$74.00
Remit to: MORENO VALLEY, CA					FYTD: \$74.00

Attachment: August2023PaymentRegisterSR (6410 : AUGUST PAYMENT REGISTER 2023)



City of Moreno Valley
Payment Register
For Period 8/1/2023 through 8/31/2023

CHECKS UNDER \$25,000

Vendor Name	Check/EFT Number	Payment Date	Inv Number	Invoice Description	Payment Amount
ACOSTA, JEANETTE	246026	08/16/2023	2003475.047	ACCOUNT CREDIT REFUND	\$62.80
Remit to: MORENO VALLEY, CA					FYTD: \$62.80
ADDICTION MEDICINE CONSULTANTS, INC.	37964	08/02/2023	2502985	CONSULTING SERVICES-APRIL 2023-HR	\$306.00
Remit to: REDLANDS, CA					FYTD: \$306.00
ADOPT A HIGHWAY LITTER REMOVAL SERVICE OF AMERICA	38192	08/30/2023	243882	MONTHLY FEE FOR LITTER REMOVAL-HWY 60 WB	\$625.00
Remit to: ENCINITAS, CA					FYTD: \$625.00
ADVANCE AVANT GARDE CORPORATION DBA AVANT GARDE IN	38025	08/09/2023	8754	HOME KEY GRANT PROGRAM-JULY 2023	\$10,500.00
Remit to: DIAMOND BAR, CA					FYTD: \$28,272.50
AHMAD, SHEISTA	246027	08/16/2023	2003524.047	ACCOUNT CREDIT REFUND	\$209.60
Remit to: MORENO VALLEY, CA					FYTD: \$209.60
AIR EXCHANGE INC	37965	08/02/2023	91610104	PLYMOVENT MAINT & REPAIR-FIRE STATIONS	\$275.45
	38140	08/23/2023	91610266	PLYMOVENT MAINT & REPAIR-FIRE STATIONS	\$2,018.76
Remit to: FAIRFIELD, CA					FYTD: \$3,551.19
AIRESPRING INC.	38026	08/09/2023	174083106	LOCAL/LONG DISTANCE CALLS & INTERNET SVC - JUL. 2023	\$2,931.36
	38141	08/23/2023	175082679	LOCAL/LONG DISTANCE CALLS & INTERNET SVC - AUG. 2023	\$2,796.00
Remit to: VAN NUYS, CA					FYTD: \$5,727.36
ALADROSS, KAMRAN	38027	08/09/2023	08/09 - 08/10/23	TRAVEL PER DIEM & MILEAGE - EUSERC COMMITTEE	\$219.08
Remit to: MORENO VALLEY, CA					FYTD: \$219.08

Attachment: August2023PaymentRegisterSR (6410 : AUGUST PAYMENT REGISTER 2023)



City of Moreno Valley
Payment Register
For Period 8/1/2023 through 8/31/2023

CHECKS UNDER \$25,000

<u>Vendor Name</u>	<u>Check/EFT Number</u>	<u>Payment Date</u>	<u>Inv Number</u>	<u>Invoice Description</u>	<u>Payment Amount</u>
ALISAM MORENO OPERATING, INC DBA WATERDROPS EXPRES	38193	08/30/2023	9	CAR WASH COUNT-POLICE-JULY 2023	\$945.00
Remit to: WOODLAND HILLS, CA					<u>FYTD:</u> \$945.00
ALLIANCE TRAILER CORP	246142	08/30/2023	24651	MATERIALS & LABOR-PARKS	\$6,253.30
Remit to: BEAUMONT, CA					<u>FYTD:</u> \$6,253.30
ALVAREZ, RICARDO	246165	08/30/2023	2003557.047	ACCOUNT CREDIT REFUND	\$2.50
Remit to: MORENO VALLEY, CA					<u>FYTD:</u> \$2.50
ALVIZ, JESSA	245987	08/09/2023	R23-174795	ANIMAL SERVICES REFUND S/N DEPOSIT	\$75.00
Remit to: RIVERSIDE, CA					<u>FYTD:</u> \$75.00
AM CONSERVATION GROUP INC	245929	08/02/2023	IN1366028	CUSTOM SLEEVE-MVU	\$3,760.48
Remit to: CHICAGO, IL					<u>FYTD:</u> \$3,760.48
AMERICAN FORENSIC NURSES	38095	08/16/2023	77918	PHLEBOTOMY SVCS-PD	\$4,010.96
		08/16/2023	77919	PHLEBOTOMY SVCS-PD	
		08/16/2023	77951	PHLEBOTOMY SVCS-PD	
		08/16/2023	77952	PHLEBOTOMY SVCS-PD	
	38142	08/23/2023	77995	PHLEBOTOMY SVCS-PD	\$291.70
38194	08/30/2023	78009	PHLEBOTOMY SVCS-PD	\$2,371.02	
Remit to: LA QUINTA, CA					<u>FYTD:</u> \$7,136.44

Attachment: August2023PaymentRegisterSR (6410 : AUGUST PAYMENT REGISTER 2023)



**City of Moreno Valley
Payment Register
For Period 8/1/2023 through 8/31/2023**

CHECKS UNDER \$25,000

<u>Vendor Name</u>	<u>Check/EFT Number</u>	<u>Payment Date</u>	<u>Inv Number</u>	<u>Invoice Description</u>	<u>Payment Amount</u>
ANIMAL PEST MANAGEMENT SERVICES, INC.	38143	08/23/2023	699448	PEST MANAGEMENT SERVICE-PARKS	\$2,655.00
		08/23/2023	700720	PEST MANAGEMENT SERVICE-PARKS	
		08/23/2023	700994	PEST MANAGEMENT SERVICE-PARKS	
		08/23/2023	701030	PEST MANAGEMENT SERVICE-PARKS	
	38195	08/30/2023	702485	PEST MANAGEMENT SERVICE-PARKS	\$150.00
Remit to: CHINO, CA					FYTD: \$2,805.00
ANSER ADVISORY MANAGEMENT, LLC.	37966	08/02/2023	W801280	ON-CALL INSPECTION SERVICES-JUNE 2023-LAND DEV	\$20,160.00
Remit to: SANTA ANA, CA					FYTD: \$39,360.00
ANTI, SHEA	246028	08/16/2023	2003476.047	ACCOUNT CREDIT REFUND	\$325.00
Remit to: MORENO VALLEY, CA					FYTD: \$325.00
APPLE ONE EMPLOYMENT SERVICES	38096	08/16/2023	S9546507	TEMP EMPLOYMENT SERVICES-WE 06/24/2023-J CERVANTES (HR)	\$8,802.08
Remit to: GLENDALE, CA					FYTD: \$8,802.08
ARAGON GEOTECHNICAL, INC.	37967	08/02/2023	8557	801 0096 CITYWIDE PVT REHAB PROG (FY 21-26)	\$12,718.00
Remit to: RIVERSIDE, CA					FYTD: \$12,718.00
ARANA, JOSEFINA	246166	08/30/2023	2003558.047	ACCOUNT CREDIT REFUND	\$20.50
Remit to: MORENO VALLEY, CA					FYTD: \$20.50
ARCHITERRA DESIGN GROUP	38196	08/30/2023	31126	807 0060 PARK REHAB & REFURBISHMENT PROGRAM	\$1,254.75
		08/30/2023	31127	807 0060 PARK REHAB & REFURBISHMENT PROGRAM	
Remit to: RANCHO CUCAMONGA, CA					FYTD: \$2,449.00

Attachment: August2023PaymentRegisterSR (6410 : AUGUST PAYMENT REGISTER 2023)



City of Moreno Valley
Payment Register
For Period 8/1/2023 through 8/31/2023

CHECKS UNDER \$25,000

Vendor Name	Check/EFT Number	Payment Date	Inv Number	Invoice Description	Payment Amount
ARIA MANAGEMENT LLC	37968	08/02/2023	AUGUST 2023	LEASE PAYMENT-LIBRARY-AUGUST 2023	\$13,852.25
	38197	08/30/2023	SEPTEMBER 2023	LEASE PAYMENT-LIBRARY @ IRIS-SEPTEMBER 2023	\$13,852.25
Remit to: YORBA LINDA, CA					FYTD: \$41,556.75
ARS BILLIARDS	245996	08/16/2023	051023	REFELT POOL TABLES (4)-PARKS	\$2,000.00
Remit to: RIVERSIDE, CA					FYTD: \$2,000.00
ARVIZU, CZARINA	246167	08/30/2023	2003559.047	ACCOUNT CREDIT REFUND	\$7.91
Remit to: MORENO VALLEY, CA					FYTD: \$7.91
AT&T MOBILITY	245997	08/16/2023	472251	CELL PHONE LOCATION/TRACKING SVCS-PD	\$450.00
Remit to: CAROL STREAM, IL					FYTD: \$450.00
AURORA MONROE SCHOOL OF DANCE	246029	08/16/2023	2003531.047	ACCOUNT CREDIT REFUND	\$1.90
Remit to: MORENO VALLEY, CA					FYTD: \$1.90
AUTOMATIC STOREFRONT SERVICE/E-Z AUTOMATED SYSTEMS	245967	08/09/2023	0032114	SLIDING GLASS DOOR PREV. MAINT.-MAIN LIBRARY	\$3,168.00
		08/09/2023	0032115	SLIDING GLASS DOOR PREV. MAINT.-SENIOR CENTER	
		08/09/2023	0032116	SLIDING GLASS DOOR PREV. MAINT.-TOWNGATE COMM. CENTER	
		08/09/2023	0032117	SLIDING GLASS DOOR PREV. MAINT.-CONFERENCE & REC CENTER	
		08/09/2023	0032118	SLIDING GLASS DOOR PREV. MAINT.-CITY HALL	
	246094	08/09/2023	0032119	SLIDING GLASS DOOR PREV. MAINT.-PUBLIC SAFETY BLDG.	
	246094	08/23/2023	0032143	NW ENTRY DOOR THRESHOLD REPAIR-PUBLIC SAFETY BLDG.	\$636.57
	246143	08/30/2023	0032151	SW DOOR DC1 CONTROL BOX/SLIDER REPAIR-PUBLIC SAFETY BLDG.	\$2,238.54
Remit to: CHINO, CA					FYTD: \$6,043.11

Attachment: August2023PaymentRegisterSR (6410 : AUGUST PAYMENT REGISTER 2023)



City of Moreno Valley
Payment Register
For Period 8/1/2023 through 8/31/2023

CHECKS UNDER \$25,000

<u>Vendor Name</u>	<u>Check/EFT Number</u>	<u>Payment Date</u>	<u>Inv Number</u>	<u>Invoice Description</u>	<u>Payment Amount</u>
BALLES, IAN	246168	08/30/2023	R23-175281	ANIMAL SERVICES REFUND S/N AND RAB DEP	\$95.00
Remit to: HUNTINGTON BEACH, CA					<u>FYTD:</u> \$95.00
BALLESTEROS, DEYADIRA	246169	08/30/2023	2003560.047	ACCOUNT CREDIT REFUND	\$20.50
Remit to: GEORGETOWN, TX					<u>FYTD:</u> \$20.50
BARBARA RUNGE DBA VIBE ENTERTAINMENT	37969	08/02/2023	2305909	PATRIOTIC STILT WALKER FOR 2023 JULY 4TH PARADE	\$900.00
Remit to: SEAL BEACH, CA					<u>FYTD:</u> \$900.00
BARNO, TRACY	246030	08/16/2023	2003477.047	ACCOUNT CREDIT REFUND	\$67.00
Remit to: PERRIS, CA					<u>FYTD:</u> \$67.00
BARRIOS, TONY	246170	08/30/2023	2003561.047	ACCOUNT CREDIT REFUND	\$34.00
Remit to: MORENO VALLEY, CA					<u>FYTD:</u> \$34.00
BECERRA, ROSETTA	245988	08/09/2023	2003498.047	ACTIVITY REFUND- VALLEY DAY CAMP	\$135.00
Remit to: MORENO VALLEY, CA					<u>FYTD:</u> \$135.00
BENTON, ANTHONY	246114	08/23/2023	R23-172646	ANIMAL SERVICES REFUND S/N DEPOSIT	\$75.00
Remit to: RIVERSIDE, CA					<u>FYTD:</u> \$75.00
BERLITZ LANGUAGES, INC.	245968	08/09/2023	001-274-23-01169	BILINGUAL EXAMS-FEBRUARY 2023	\$1,360.00
		08/09/2023	001-274-23-01630	BILINGUAL EXAMS-APRIL 2023	
		08/09/2023	001-274-23-01631	BILINGUAL EXAMS-MARCH 2023	
Remit to: PRINCETON, NJ					<u>FYTD:</u> \$2,585.00

Attachment: August2023PaymentRegisterSR (6410 : AUGUST PAYMENT REGISTER 2023)



City of Moreno Valley
Payment Register
For Period 8/1/2023 through 8/31/2023

CHECKS UNDER \$25,000

Vendor Name	Check/EFT Number	Payment Date	Inv Number	Invoice Description	Payment Amount
BMW MOTORCYCLES OF RIVERSIDE	38144	08/23/2023	6033746	MAINT & REPAIRS-TRAFFIC MOTORCYCLE	\$7,224.78
		08/23/2023	6033771	MAINT & REPAIRS-TRAFFIC MOTORCYCLE	
		08/23/2023	6033782	MAINT & REPAIRS-TRAFFIC MOTORCYCLE	
		08/23/2023	6033836	MAINT & REPAIRS-TRAFFIC MOTORCYCLE	
		08/23/2023	6033934	MAINT & REPAIRS-TRAFFIC MOTORCYCLE	
		08/23/2023	6033940	MAINT & REPAIRS-TRAFFIC MOTORCYCLE	
	38198	08/30/2023	6034010	MAINT & REPAIRS-TRAFFIC MOTORCYCLE	
		08/30/2023	6034115	MAINT & REPAIRS-TRAFFIC MOTORCYCLE	\$384.76
Remit to: RIVERSIDE, CA					FYTD: \$13,246.69
BOB MURRAY & ASSOCIATES	246144	08/30/2023	10223	PROFESSIONAL SVCS-EXECUTIVE RECRUITMENT-ECON & HOUSING DIRECTOR	\$6,427.25
		08/30/2023	10224	PROFESSIONAL SVCS-EXECUTIVE RECRUITMENT-HR DIRECTOR	
Remit to: ROSEVILLE, CA					FYTD: \$24,807.25
BOGAN, SHAVON	246171	08/30/2023	2003562.047	ACCOUNT CREDIT REFUND	\$44.00
Remit to: MORENO VALLEY, CA					FYTD: \$44.00
BONLAJOR DBA DUKE SERVICE COMPANY	38029	08/09/2023	382272	COFFEE MAKER REPAIR-FIRE STATION #91	\$613.32
Remit to: ANAHEIM, CA					FYTD: \$613.32

Attachment: August2023PaymentRegisterSR (6410 : AUGUST PAYMENT REGISTER 2023)



City of Moreno Valley
Payment Register
For Period 8/1/2023 through 8/31/2023

CHECKS UNDER \$25,000

<u>Vendor Name</u>	<u>Check/EFT Number</u>	<u>Payment Date</u>	<u>Inv Number</u>	<u>Invoice Description</u>	<u>Payment Amount</u>
BOX SPRINGS MUTUAL WATER COMPANY	245930	08/02/2023	1084-1 7/28/23	WATER ASSESSMENT ON VACANT LOTS OWNED BY THE HOUSING AUTHORITY	\$542.74
		08/02/2023	1085-1 7/28/23	WATER ASSESSMENT ON VACANT LOTS OWNED BY THE HOUSING AUTHORITY	
		08/02/2023	1086-1 7/28/23	WATER ASSESSMENT ON VACANT LOTS OWNED BY THE HOUSING AUTHORITY	
		08/02/2023	1087-1 7/28/23	WATER ASSESSMENT ON VACANT LOTS OWNED BY THE HOUSING AUTHORITY	
		08/02/2023	1088-1 7/28/23	WATER ASSESSMENT ON VACANT LOTS OWNED BY THE HOUSING AUTHORITY	
		08/02/2023	189-13 7/28/23	WATER ASSESSMENT ON VACANT LOTS OWNED BY THE HOUSING AUTHORITY	
		08/02/2023	195-5 7/28/23	WATER ASSESSMENT ON VACANT LOTS OWNED BY THE HOUSING AUTHORITY	
		08/02/2023	204-9 7/28/23	WATER ASSESSMENT ON VACANT LOTS OWNED BY THE HOUSING AUTHORITY	
		08/02/2023	331-1 7/28/23	WATER ASSESSMENT ON VACANT LOTS OWNED BY THE HOUSING AUTHORITY	
		08/02/2023	36-1 7/28/23	WATER ASSESSMENT ON VACANT LOTS OWNED BY THE HOUSING AUTHORITY	
	08/02/2023	45-4 7/28/23	WATER ASSESSMENT ON VACANT LOTS OWNED BY THE HOUSING AUTHORITY		
	08/02/2023	721-1 7/28/23	WATER USAGE-TOWNGATE-JULY 2023		
	08/02/2023	80-4 7/28/23	WATER ASSESSMENT ON VACANT LOTS OWNED BY THE HOUSING AUTHORITY		

Remit to: MORENO VALLEY, CA

FYTD: \$973.16

BRAUN BLAISING SMITH WYNNE, P.C.

38030 08/09/2023 21280

LEGAL SERVICES-MV UTILITY-JUNE 2023

\$1,129.34

Remit to: SACRAMENTO, CA

FYTD: \$3,184.79

Attachment: August2023PaymentRegisterSR (6410 : AUGUST PAYMENT REGISTER 2023)



City of Moreno Valley
Payment Register
For Period 8/1/2023 through 8/31/2023

CHECKS UNDER \$25,000

Vendor Name	Check/EFT Number	Payment Date	Inv Number	Invoice Description	Payment Amount
BRIGHTER NOW & JONES CONSULTING LLC	245969	08/09/2023	8/03/2023	HIRE A MOVAL GRAD INCENTIVE PROGRAM PARTICIPATION	\$3,000.00
Remit to: MORENO VALLEY, CA					FYTD: \$3,000.00
BROADNAX, NICOLE	246031	08/16/2023	2003479.047	ACCOUNT CREDIT REFUND	\$67.00
Remit to: RIVERSIDE, CA					FYTD: \$67.00
BROCK, JO	246172	08/30/2023	2003563.047	ACCOUNT CREDIT REFUND	\$27.00
Remit to: LONG BEACH, CA					FYTD: \$27.00
BROWN, ANGELA	246032	08/16/2023	2003480.047	ACCOUNT CREDIT REFUND	\$38.10
Remit to: SAN JACINTO, CA					FYTD: \$38.10
BROWN, JARREL	246115	08/23/2023	2003551.047	REFUND- PICNIC SHELTER	\$96.75
Remit to: MORENO VALLEY, CA					FYTD: \$96.75
BROWN, TERESA	246033	08/16/2023	2003525.047	ACCOUNT CREDIT REFUND	\$300.00
Remit to: MORENO VALLEY, CA					FYTD: \$300.00
BROWNE, KALEE	246034	08/16/2023	2003481.047	ACCOUNT CREDIT REFUND	\$67.00
Remit to: RIVERSIDE, CA					FYTD: \$67.00
CABANILLAS, KATHERYN	246035	08/16/2023	2003482.047	ACCOUNT CREDIT REFUND	\$165.00
Remit to: PERRIS, CA					FYTD: \$165.00
CABRAL, LIZA	246173	08/30/2023	2003565.047	ACCOUNT CREDIT REFUND	\$50.00
Remit to: MORENO VALLEY, CA					FYTD: \$50.00

Attachment: August2023PaymentRegisterSR (6410 : AUGUST PAYMENT REGISTER 2023)



**City of Moreno Valley
Payment Register
For Period 8/1/2023 through 8/31/2023**

CHECKS UNDER \$25,000

<u>Vendor Name</u>	<u>Check/EFT Number</u>	<u>Payment Date</u>	<u>Inv Number</u>	<u>Invoice Description</u>	<u>Payment Amount</u>
CALIFORNIA ASSOCIATION OF CODE ENFORCEMENT OFFICER	245931	08/02/2023	200025646	MODULE THREE 10.16.2023 - JORGE RUVALCABA-CODE ENF	\$2,000.00
		08/02/2023	200026019	MODULE TWO 9.18.2023 - RAMON ZAMUDIO-CODE ENF	
		08/02/2023	200026020	MODULE THREE 10.16.2023 - RAMON ZAMUDIO-CODE ENF	
		08/02/2023	200026021	MODULE TWO 9.18.2023 - ALEJANDRO MERAZ-CODE ENF	
	245998	08/16/2023	200025267	MODULE ONE 8.14.23-DAVID JOUZI-CODE ENF	\$1,154.00
		08/16/2023	200026157	WEBINAR 9.27.23-JORGE RUVALCABA-CODE ENF	
	246095	08/23/2023	200026275	MODULE THREE 10.16.2023 - ERIK FLORES - CODE ENF	\$2,500.00
		08/23/2023	200026276	MODULE TWO 9.18.2023 - DAVID JOUZI - CODE ENF	
		08/23/2023	200026277	MODULE THREE 10.16.2023 - DAVID JOUZI - CODE ENF	
		08/23/2023	200026319	MODULE THREE 10.16.2023 - ALEJANDRO MERAZ - CODE ENF	
	08/23/2023	200026322	MODULE TWO 9.18.2023 - ROSA MORALES - CODE ENF		
Remit to: SACRAMENTO, CA					FYTD: \$6,154.00
CALIFORNIA NEWSPAPERS PARTNERSHIP	38031	08/09/2023	028765C2-0001	AD #0011598238/ACCT #5209144 - PUBLIC HEARING NTC	\$130.88
Remit to: WILLOUGHBY, OH					FYTD: \$1,938.11
CAMARENA, LIZETH	245989	08/09/2023	2003489.047	DEPOSIT REFUND-TOWNGATE COMM. CTR	\$230.50
Remit to: MORENO VALLEY, CA					FYTD: \$230.50
CAMERON-DANIEL, P.C.	38032	08/09/2023	1429	LEGAL SERVICES-MV UTILITY-JUNE 2023	\$6,923.50
		08/09/2023	1437	LEGAL SERVICES-MV UTILITY-JULY 2023	
		08/09/2023	1438	LEGAL SERVICES-MV UTILITY-JULY 2023	
Remit to: SEBASTOPOL, CA					FYTD: \$16,686.00
CART GUY LLC DBA THE CART GUY	38033	08/09/2023	128956	GOLF CART RENTALS-7/4/23-PARKS	\$2,912.02
Remit to: BANNING, CA					FYTD: \$3,272.40

Attachment: August2023PaymentRegisterSR (6410 : AUGUST PAYMENT REGISTER 2023)



**City of Moreno Valley
Payment Register
For Period 8/1/2023 through 8/31/2023**

CHECKS UNDER \$25,000

<u>Vendor Name</u>	<u>Check/EFT Number</u>	<u>Payment Date</u>	<u>Inv Number</u>	<u>Invoice Description</u>	<u>Payment Amount</u>
CASC ENGINEERING AND CONSULTING, INC.	37970	08/02/2023	0049020	PLAN CHECK SVCS-PWQMP-MAY 2023	\$6,390.00
		08/02/2023	0049218	PLAN CHECK SVCS-PWQMP-JUNE 2023	
Remit to: COLTON, CA					FYTD: \$19,176.58
CATHYJON ENTERPRISES, INC. DBA HB STAFFING	38034	08/09/2023	4196342	HR ANALYST Y. FIND-PERIOD ENDING 6/11/23-HUMAN RESOURCES	\$1,625.09
Remit to: HUNTINGTON BEACH, CA					FYTD: \$10,762.08
CAVE, DEBRA	246036	08/16/2023	R23-175270	ANIMAL SERVICES REFUND OUT OF AREA LICENSE	\$15.00
Remit to: BEAUMONT, CA					FYTD: \$15.00
CCS DISASTER RECOVERY SERVICES, LLC	38145	08/23/2023	6666	DISASTER RECOVERY SVCS ANNUAL SUBSCRIPTION-TECH SVCS	\$3,420.00
Remit to: COSTA MESA, CA					FYTD: \$3,420.00
CELLEBRITE USA, CORP	38199	08/30/2023	Q-328643-2	REGISTRATION-CERTIFIED OPR & PHYS ANALYST CRSE-J NARANJO-POLICE	\$8,400.00
		08/30/2023	Q-331487-3	REGISTRATION-CERTIFIED OPR & PHYS ANALYST CRSE-A MCCRACKE-POLICE	
Remit to: GLEN ROCK, NJ					FYTD: \$8,400.00
CHANDLER ASSET MANAGEMENT, INC	38035	08/09/2023	2307MORENOVA	INVESTMENT MANAGEMENT SVCS-JULY 2023	\$8,738.00
Remit to: SAN DIEGO, CA					FYTD: \$17,482.46
CHARTER COMMUNICATIONS HOLDINGS, LLC	38036	08/09/2023	091922301070123	FIBER INTERNET ACCESS SERVICES - JUL. 2023	\$844.00
	38146	08/23/2023	091922301080123	FIBER INTERNET ACCESS SERVICES - AUG. 2023	\$844.00
Remit to: PITTSBURGH, PA					FYTD: \$7,480.34

Attachment: August2023PaymentRegisterSR (6410 : AUGUST PAYMENT REGISTER 2023)



City of Moreno Valley
Payment Register
 For Period 8/1/2023 through 8/31/2023

CHECKS UNDER \$25,000

<u>Vendor Name</u>	<u>Check/EFT Number</u>	<u>Payment Date</u>	<u>Inv Number</u>	<u>Invoice Description</u>	<u>Payment Amount</u>
CHRIS ALAN VOGT DBA CAV CONSULTING	38200	08/30/2023	21060	PROJECT MANAGER CONSULTING SERVICES (CPD)	\$23,337.50
Remit to: RIVERSIDE, CA					FYTD: \$35,714.00
CINTAS CORPORATION NO. 2	37972	08/02/2023	4159010623	UNIFORM RENTAL & LAUNDERING SRVS FY 22/23	\$2,850.24
		08/02/2023	4159706288	UNIFORM RENTAL & LAUNDERING SRVS FY 22/23	
		08/02/2023	9229152291	CREDIT FOR UNIFORMS-B DAVIS@STREET MAINT	
	38147	08/23/2023	4160425235	UNIFORM RENTAL & LAUNDERING SRVS FY 23/24	\$7,445.15
		08/23/2023	4161072434	UNIFORM RENTAL & LAUNDERING SRVS FY 23/24	
		08/23/2023	4161754996	UNIFORM RENTAL & LAUNDERING SRVS FY 23/24	
		08/23/2023	4162423057	UNIFORM RENTAL & LAUNDERING SRVS FY 23/24	
		08/23/2023	4163127499	UNIFORM RENTAL & LAUNDERING SRVS FY 23/24	
Remit to: CINCINNATI, OH					FYTD: \$11,721.86
CITY OF RIVERSIDE	245970	08/09/2023	00271559	TRAFFIC SIGNAL REPAIRS_CAMPUS PKWY & DAY ST	\$11,872.63
Remit to: RIVERSIDE, CA					FYTD: \$11,872.63
CIVIC SOLUTIONS, INC	37973	08/02/2023	063023	PLANNING ENTITLEMENT AND PLAN CHECK SVCS-JUNE 2023	\$14,862.50
Remit to: MISSION VIEJO, CA					FYTD: \$14,862.50
CLOMERA, LESLIE	246037	08/16/2023	2003501.047	ACCOUNT CREDIT REFUND	\$95.00
Remit to: MORENO VALLEY, CA					FYTD: \$95.00
COATS, DAVID	38148	08/23/2023	JULY 2023	INSTRUCTOR SERVICES - SHITO-RYU KARATE CLASSES	\$547.20
Remit to: MORENO VALLEY, CA					FYTD: \$1,003.20
COLONIAL SUPPLEMENTAL INSURANCE	246096	08/23/2023	71330690901336	EMPLOYEE SUPPLEMENTAL INSURANCE	\$6,413.01
Remit to: COLUMBIA, SC					FYTD: \$6,413.01

Attachment: August2023PaymentRegisterSR (6410 : AUGUST PAYMENT REGISTER 2023)



**City of Moreno Valley
Payment Register
For Period 8/1/2023 through 8/31/2023**

CHECKS UNDER \$25,000

<u>Vendor Name</u>	<u>Check/EFT Number</u>	<u>Payment Date</u>	<u>Inv Number</u>	<u>Invoice Description</u>	<u>Payment Amount</u>
COMPULINK MANAGEMENT CENTER, INC. - DBA LASERFICHE	38037	08/09/2023	5529COMV	NEW RECORDS MGMT IMPLEMENTATION-MAY 2023	\$10,152.00
Remit to: LONG BEACH, CA					FYTD: \$10,152.00
CONTRERAS, LORI	246038	08/16/2023	2003535.047	ACCOUNT CREDIT REFUND	\$4.00
Remit to: MORENO VALLEY, CA					FYTD: \$4.00
CORODATA MEDIA STORAGE INC.	38098	08/16/2023	DS1306045	OFF-SITE MEDIA STORAGE-JULY 2023	\$489.72
Remit to: LOS ANGELES, CA					FYTD: \$1,044.37
COSCO FIRE PROTECTION, INC.	38038	08/09/2023	1000622935	ANNUAL FIRE EXTINGUISHER INSPECTION-FIRE STATION 6	\$420.00
		08/09/2023	1000623130	ANNUAL FIRE EXTINGUISHER INSPECTION-PUBLIC SAFETY BLDG.	
		08/09/2023	1000623131	ANNUAL FIRE EXTINGUISHER INSPECTION-FIRE STATION 2 REAR	
	38149	08/23/2023	1000626997	FIRE HYDRANT SERVICE LEAK-FIRE STATION 99	\$340.00
Remit to: BREA, CA					FYTD: \$820.00
COUNSELING TEAM, THE	245999	08/16/2023	87581	EMPLOYEE ASSISTANCE PROGRAM-JULY 2023	\$1,950.00
	246145	08/30/2023	87811	EMPLOYEE ASSISTANCE PROGRAM-AUGUST 2023	\$1,950.00
Remit to: SAN BERNARDINO, CA					FYTD: \$3,900.00
COUNTS UNLIMITED, INC.	37974	08/02/2023	23320	TRAFFIC DATA COLLECTION	\$960.00
		08/02/2023	23374	TRAFFIC DATA COLLECTION	
		08/02/2023	23384	TRAFFIC DATA COLLECTION	
		08/02/2023	23386	TRAFFIC DATA COLLECTION	
		08/02/2023	23420	TRAFFIC DATA COLLECTION	
		08/02/2023	23458	TRAFFIC DATA COLLECTION	
	38039	08/09/2023	23014	DIRECT PAY_801 0086 JUAN BAUTISTA TRAIL ATP 4	\$13,200.00
Remit to: CORONA, CA					FYTD: \$14,160.00

Attachment: August2023PaymentRegisterSR (6410 : AUGUST PAYMENT REGISTER 2023)



City of Moreno Valley
Payment Register
For Period 8/1/2023 through 8/31/2023

CHECKS UNDER \$25,000

<u>Vendor Name</u>	<u>Check/EFT Number</u>	<u>Payment Date</u>	<u>Inv Number</u>	<u>Invoice Description</u>	<u>Payment Amount</u>
COUNTY OF RIVERSIDE	245972	08/09/2023	3894	REGISTERED VOTERS CONFIRMATION-CFD NO. 2021-01/AMENDMENT NO. 93	\$420.00
		08/09/2023	3895	REGISTERED VOTERS CONFIRMATION-CFD NO. 2021-01/AMENDMENT NO. 105	
		08/09/2023	3897	REGISTERED VOTERS CONFIRMATION-CFD NO. 2021-01/AMENDMENT NO. 108	
		08/09/2023	3901	REGISTERED VOTERS CONFIRMATION-CFD NO. 2021-01/AMENDMENT NO. 106	
		08/09/2023	3902	REGISTERED VOTERS CONFIRMATION-CFD NO. 2021-01/AMENDMENT NO. 110	
		08/09/2023	3903	REGISTERED VOTERS CONFIRMATION-CFD NO. 2014-01/AMENDMENT NO. 81	
	246000	08/16/2023	PE0000001166	TRAFFIC MOTOR COMMUNICATIONS FOR PD 7/1-7/31/23	\$1,915.62
	246001	08/16/2023	23-168934	MAP RECORDATION WITH COPIES - JUNE 2023	\$348.00
	246002	08/16/2023	3910	REGISTERED VOTERS CONFIRMATION-CFD NO. 2021-01/AMENDMENT NO. 79	\$420.00
		08/16/2023	3911	REGISTERED VOTERS CONFIRMATION-CFD NO. 2014-01/AMENDMENT NO. 79	
		08/16/2023	3912	REGISTERED VOTERS CONFIRMATION-CFD NO. 2021-01/AMENDMENT NO. 111	
		08/16/2023	3913	REGISTERED VOTERS CONFIRMATION-CFD NO. 2021-01/AMENDMENT NO. 102	
		08/16/2023	3914	REGISTERED VOTERS CONFIRMATION-CFD NO. 2021-01/AMENDMENT NO. 60	
		08/16/2023	3915	REGISTERED VOTERS CONFIRMATION-CFD NO. 2021-01/AMENDMENT NO. 90	

Attachment: August2023PaymentRegisterSR (6410 : AUGUST PAYMENT REGISTER 2023)



City of Moreno Valley
Payment Register
For Period 8/1/2023 through 8/31/2023

CHECKS UNDER \$25,000

<u>Vendor Name</u>	<u>Check/EFT Number</u>	<u>Payment Date</u>	<u>Inv Number</u>	<u>Invoice Description</u>	<u>Payment Amount</u>
COUNTY OF RIVERSIDE	246003	08/16/2023	BCTC0062910_	REGISTRATION-J. ARELLANO-SELF DEFENSE & TACTICAL COMM. 9/28/23	\$369.00
		08/16/2023	BCTC0062911_	REGISTRATION-J. JOSEPH-SELF DEFENSE & TACTICAL COMM. 9/28/23	
		08/16/2023	BCTC0064286	REGISTRATION-C. GUZMAN-SELF DEFENSE & TACTICAL COMM. 9/28/23	
	246146	08/30/2023	3916	REGISTERED VOTERS CONFIRMATION-CFD NO. 2021-01/AMENDMENT NO. 112	\$490.00
		08/30/2023	3917	REGISTERED VOTERS CONFIRMATION-CFD NO. 2021-01/AMENDMENT NO. 113	
		08/30/2023	3918	REGISTERED VOTERS CONFIRMATION-CFD NO. 2021-01/AMENDMENT NO. 104	
		08/30/2023	3919	REGISTERED VOTERS CONFIRMATION-CFD NO. 2021-01/AMENDMENT NO. 114	
		08/30/2023	3920	REGISTERED VOTERS CONFIRMATION-CFD NO. 2021-01/AMENDMENT NO. 116	
		08/30/2023	3923	REGISTERED VOTERS CONFIRMATION-CFD NO. 2021-01/AMENDMENT NO. 115	
		08/30/2023	3924	REGISTERED VOTERS CONFIRMATION-CFD NO. 2021-01/AMENDMENT NO. 109	
Remit to: RIVERSIDE, CA					FYTD: \$18,764.38
COUNTY OF RIVERSIDE - HHPWS-COC	38099	08/16/2023	3 /ESG FY 21/22	ESG SUBRECIPIENT PAYMENT-HOMELESS MGMT INFO SYSTEM PROGRAM	\$14,537.93
Remit to: RIVERSIDE, CA					FYTD: \$14,537.93
COUNTY OF RIVERSIDE, AUDITOR- CONTROLLER	246147	08/30/2023	JULY 2023	TRANSMITTAL OF AB544 FROM PARKING CONTROL FEES	\$22,875.77
Remit to: RIVERSIDE, CA					FYTD: \$42,328.74

Attachment: August2023PaymentRegisterSR (6410 : AUGUST PAYMENT REGISTER 2023)



City of Moreno Valley
Payment Register
For Period 8/1/2023 through 8/31/2023

CHECKS UNDER \$25,000

Vendor Name	Check/EFT Number	Payment Date	Inv Number	Invoice Description	Payment Amount
COVARRUBIAS, JAVIER	246039	08/16/2023	2003502.047	ACCOUNT CREDIT REFUND	\$67.00
Remit to: MORENO VALLEY, CA					FYTD: \$67.00
CRIME SCENE STERI-CLEAN, LLC	38100	08/16/2023	43786	BIO HAZARD REMOVAL SERVICE	\$1,150.00
Remit to: RANCHO CUCAMONGA, CA					FYTD: \$2,000.00
CROWN CASTLE FIBER LLC	38041	08/09/2023	1375614	INTERNET & DATA SVCS 07/01-07/31/23	\$2,518.75
		08/09/2023	1394503	INTERNET & DATA SVCS 08/01/23-08/31/23	
Remit to: HOUSTON, TX					FYTD: \$2,518.75
CUADROS MONTALVO, RONNY	246174	08/30/2023	R23-175303	ANIMAL SERVICES REFUND S/N DEPOSIT	\$75.00
Remit to: MORENO VALLEY, CA					FYTD: \$75.00
CWE CORP.	37977	08/02/2023	23252	PLAN CHECK SVCS-PWQMP-MAY 2023	\$3,589.00
		08/02/2023	23268	PLAN CHECK SVCS-PWQMP-JUNE 2023	
Remit to: FULLERTON, CA					FYTD: \$3,589.00
DANG, TRINA	246040	08/16/2023	2003503.047	ACCOUNT CREDIT REFUND	\$37.00
Remit to: MORENO VALLEY, CA					FYTD: \$37.00
DDL TRAFFIC INC.	38151	08/23/2023	8558	TYPE 1 A 16' POLES (2)-TRANSPORTATION	\$3,868.23
Remit to: CHINO HILLS, CA					FYTD: \$3,868.23
DEEGAN, BILL	246041	08/16/2023	2003526.047	ACCOUNT CREDIT REFUND	\$200.00
Remit to: THEODORE, AL					FYTD: \$200.00
DEITELBAUM, JODI	246175	08/30/2023	R23-175644	ANIMAL SERVICES REFUND S/N AND RAB DEP	\$95.00
Remit to: GARDEN GROVE, CA					FYTD: \$95.00

Attachment: August2023PaymentRegisterSR (6410 : AUGUST PAYMENT REGISTER 2023)



City of Moreno Valley
Payment Register
For Period 8/1/2023 through 8/31/2023

CHECKS UNDER \$25,000

<u>Vendor Name</u>	<u>Check/EFT Number</u>	<u>Payment Date</u>	<u>Inv Number</u>	<u>Invoice Description</u>	<u>Payment Amount</u>
DELGADO, KELLI	246042	08/16/2023	2003504.047	ACCOUNT CREDIT REFUND	\$67.00
Remit to: MORENO VALLEY, CA					<u>FYTD:</u> \$67.00
DELL, INC.	38043	08/09/2023	10660834154	VLA ENTERPRISE PROJECT P3 GCC SUB PER USER-TECH SVCS	\$2,904.20
Remit to: ROUND ROCK, TX					<u>FYTD:</u> \$2,904.20
DELTA DENTAL OF CALIFORNIA	38044	08/09/2023	BE005563458	EMPLOYEE DENTAL INSURANCE-PPO	\$16,231.73
	38045	08/09/2023	BE005564200	EMPLOYEE DENTAL INSURANCE-HMO	\$3,658.95
	38101	08/16/2023	BE005631330	EMPLOYEE DENTAL INSURANCE-PPO	\$16,556.69
	38102	08/16/2023	BE005632056	EMPLOYEE DENTAL INSURANCE-HMO	\$3,638.01
	38201	08/30/2023	BE005658506	EMPLOYEE DENTAL INSURANCE-PPO	\$17,117.93
	38202	08/30/2023	BE005659287	EMPLOYEE DENTAL INSURANCE-HMO	\$3,722.58
Remit to: LOS ANGELES, CA					<u>FYTD:</u> \$80,301.28
DEPARTMENT OF ENVIRONMENTAL HEALTH	245932	08/02/2023	APR.-JUNE 2023	VECTOR CONTROL SERVICES-CODE	\$9,927.10
Remit to: RIVERSIDE, CA					<u>FYTD:</u> \$9,927.10
DEPARTMENT OF TREASURY	38389	08/31/2023	FAIN: ERA0351	ERAP1 RETURNED FUNDS-PAID VIA PAY.GOV (TRACKING ID 2771425B)	\$9,609.86
Remit to: WASHINGTON, DC					<u>FYTD:</u> \$9,609.86

Attachment: August2023PaymentRegisterSR (6410 : AUGUST PAYMENT REGISTER 2023)



City of Moreno Valley
Payment Register
For Period 8/1/2023 through 8/31/2023

CHECKS UNDER \$25,000

<u>Vendor Name</u>	<u>Check/EFT Number</u>	<u>Payment Date</u>	<u>Inv Number</u>	<u>Invoice Description</u>	<u>Payment Amount</u>
DIAMOND ENVIRONMENTAL SERVICES, LP	245973	08/09/2023	0004797255	PORTABLE RESTROOM RENTAL-MAINT & OP'S	\$449.71
	246004	08/16/2023	0004566619	PORTABLE RESTROOM RENTAL-EARTH DAY 2023-PARKS MAINT	\$1,745.74
		08/16/2023	0004691644	PORTABLE RESTROOM RENTAL-JUNETEENTH-PARKS MAINT	
		08/16/2023	0004789364	PORTABLE RESTROOM RENTAL-POLICE DEPT	
	246097	08/23/2023	0004674780	PORTABLE RESTROOM RENTAL-4TH OF JULY FIREWORK ZONE-PARKS	\$10,092.74
		08/23/2023	0004674785	PORTABLE RESTROOM RENTAL-4TH OF JULY PARADE-PARKS	
		08/23/2023	0004674804	PORTABLE RESTROOM RENTAL-4TH OF JULY-PARKS	
		08/23/2023	0004797253	PORTABLE RESTROOM RENTAL-MV EQUESTRIAN CTR	
		08/23/2023	0004797254	PORTABLE RESTROOM RENTAL-COTTONWOOD GOLF CTR	
		08/23/2023	0004847603	PORTABLE RESTROOM RENTAL-POLICE DEPT	
	246148	08/30/2023	0004657464	PORTABLE RESTROOM RENTAL-PUBLIC SAFETY EXPO-PARKS MAINT	\$2,128.11
		08/30/2023	0004808679	PORTABLE RESTROOM RENTAL-COMMUNITY SERVICE DAY-PARKS MAINT	
		08/30/2023	0004856443	PORTABLE RESTROOM RENTAL-MAINT & OP'S	
Remit to: SAN MARCOS, CA					<u>FYTD:</u> \$15,135.42
DISABILITY ACCESS CONSULTANTS	38046	08/09/2023	23-100	801 0008 DAC ACCESSIBILITY MGMT SOFTWARE ANNUAL SUBSCRIPTION	\$2,000.00
Remit to: OROVILLE, CA					<u>FYTD:</u> \$2,000.00
DISH DBS CORPORATION	245974	08/09/2023	86557282/AUG23	SATELLITE TV-FIRE STATION 99-07/31-08/30/23	\$151.41
Remit to: PALATINE, IL					<u>FYTD:</u> \$302.82
DODSON, KATHERINE	246043	08/16/2023	R23-173636	ANIMAL SERVICES REFUND S/N DEPOSIT	\$75.00
Remit to: BEAUMONT, CA					<u>FYTD:</u> \$75.00

Attachment: August2023PaymentRegisterSR (6410 : AUGUST PAYMENT REGISTER 2023)



City of Moreno Valley
Payment Register
For Period 8/1/2023 through 8/31/2023

CHECKS UNDER \$25,000

Vendor Name	Check/EFT Number	Payment Date	Inv Number	Invoice Description	Payment Amount
E.R. BLOCK PLUMBING & HEATING, INC.	37978	08/02/2023	139498-2	BACKFLOW DEVICE TEST-PARKS	\$25.00
	38047	08/09/2023	139551	BACKFLOW DEVICE TEST-FIRE STATION 6	\$925.00
		08/09/2023	139552	BACKFLOW DEVICE TEST-FIRE STATION 65	
		08/09/2023	139553	BACKFLOW DEVICE TEST-PUBLIC SAFETY BLDG.	
		08/09/2023	139733	SD BACKFLOW TESTING BASE JULY 23	
		08/09/2023	139849	BACKFLOW DEVICE TEST-FIRE STATION 99	
	38152	08/09/2023	139850	BACKFLOW DEVICE TEST-FIRE STATION 58	
		08/23/2023	139565	BACKFLOW DEVICE TEST-PARKS	\$610.94
		08/23/2023	139753	BACKFLOW DEVICE TEST-PARKS & FACILITIES	
		08/23/2023	139828	REPAIR BACKFLOW DEVICE-PARKS	
Remit to: RIVERSIDE, CA					FYTD: \$2,661.25
EASE OF CALIFORNIA	246044	08/16/2023	BOM23-0240	REFUND PERMIT FEES-PROJECT CANCELLED-13299 NINEBARK	\$191.20
Remit to: MURRIETA, CA					FYTD: \$191.20
EASTERN MUNICIPAL WATER DISTRICT	245975	08/09/2023	JUL-23 8/9/23	WATER CHARGES	\$4,904.71
	246149	08/30/2023	AUG-23 8/30/23	WATER CHARGES	\$8,534.29
Remit to: LOS ANGELES, CA					FYTD: \$506,232.78
EC & AM ASSOCIATES, INC. DBA GK & ASSOCIATES	37979	08/02/2023	23-049	801 0089 CITYWIDE PVT REHAB FY 21/22	\$18,069.10
	38203	08/30/2023	23-055	801 0089 CITYWIDE PVT REHAB FY 21/22	\$10,102.55
Remit to: DIAMOND BAR, CA					FYTD: \$28,171.65
ECCLES, CATHY	246116	08/23/2023	R23-173180	ANIMAL SERVICES REFUND S/N DEPOSIT	\$75.00
Remit to: RIVERSIDE, CA					FYTD: \$75.00

Attachment: August2023PaymentRegisterSR (6410 : AUGUST PAYMENT REGISTER 2023)



City of Moreno Valley
Payment Register
For Period 8/1/2023 through 8/31/2023

CHECKS UNDER \$25,000

<u>Vendor Name</u>	<u>Check/EFT Number</u>	<u>Payment Date</u>	<u>Inv Number</u>	<u>Invoice Description</u>	<u>Payment Amount</u>
ELKHOURY, BADIH	246117	08/23/2023	2003545.047	ACTIVITY REFUND- VOVINAM MARTIAL ARTS	\$41.20
Remit to: MORENO VALLEY, CA					<u>FYTD:</u> \$41.20
ELKINS, DEBORAH	38204	08/30/2023	JUL. 2023	INSTRUCTOR SERVICES - ADAPTIVE ZUMBA CLASS	\$68.40
Remit to: MORENO VALLEY, CA					<u>FYTD:</u> \$136.80
EMPLOYMENT DEVELOPMENT DEPARTMENT	38286	08/21/2023	1ST QUARTER 2023	1ST QUARTER 2023	\$7,645.29
Remit to: SACRAMENTO, CA					<u>FYTD:</u> \$7,645.29

Attachment: August2023PaymentRegisterSR (6410 : AUGUST PAYMENT REGISTER 2023)



City of Moreno Valley
Payment Register
For Period 8/1/2023 through 8/31/2023

CHECKS UNDER \$25,000

<u>Vendor Name</u>	<u>Check/EFT Number</u>	<u>Payment Date</u>	<u>Inv Number</u>	<u>Invoice Description</u>	<u>Payment Amount</u>
ENCO UTILITY SERVICES MORENO VALLEY LLC	37980	08/02/2023	C23-05	INDIAN ST SOUTH OF NANDINA AVE-VEHICLE HIT STREETLIGHT	\$19,897.41
		08/02/2023	C23-11	PERRIS SOUTH OF GENTIAN-VEHICLE HIT SWITCH S721	
		08/02/2023	INV58109	METERS & SVCS-ROC 111 CA BELAGO LLC-MVU	
		08/02/2023	INV60521	SOLAR SYSTEM INSPECTION	
		08/02/2023	INV60522	SOLAR SYSTEM INSPECTION	
		08/02/2023	INV60523	SOLAR SYSTEM INSPECTION	
		08/02/2023	INV60525	SOLAR SYSTEM INSPECTION	
		08/02/2023	INV60526	SOLAR SYSTEM INSPECTION	
		08/02/2023	INV60665	SOLAR SYSTEM INSPECTION	
		08/02/2023	INV60666	SOLAR SYSTEM INSPECTION	
		08/02/2023	INV60667	SOLAR SYSTEM INSPECTION	
	38205	08/30/2023	INV61261	SOLAR SYSTEM INSPECTION	\$4,848.00
		08/30/2023	INV61262	SOLAR SYSTEM INSPECTION	
		08/30/2023	INV61263	SOLAR SYSTEM INSPECTION	
		08/30/2023	INV61264	SOLAR SYSTEM INSPECTION	
		08/30/2023	INV61265	SOLAR SYSTEM INSPECTION	
		08/30/2023	INV61266	SOLAR SYSTEM INSPECTION	
		08/30/2023	INV61267	SOLAR SYSTEM INSPECTION	
		08/30/2023	INV61268	SOLAR SYSTEM INSPECTION	
		08/30/2023	INV61269	SOLAR SYSTEM INSPECTION	
		08/30/2023	INV61270	SOLAR SYSTEM INSPECTION	
		08/30/2023	INV61271	SOLAR SYSTEM INSPECTION	
		08/30/2023	INV61272	SOLAR SYSTEM INSPECTION	
		08/30/2023	INV61273	SOLAR SYSTEM INSPECTION	
		08/30/2023	INV61274	SOLAR SYSTEM INSPECTION	
		08/30/2023	INV61275	SOLAR SYSTEM INSPECTION	
		08/30/2023	INV61276	SOLAR SYSTEM INSPECTION	

Attachment: August2023PaymentRegisterSR (6410 : AUGUST PAYMENT REGISTER 2023)



**City of Moreno Valley
Payment Register
For Period 8/1/2023 through 8/31/2023**

CHECKS UNDER \$25,000

<u>Vendor Name</u>	<u>Check/EFT Number</u>	<u>Payment Date</u>	<u>Inv Number</u>	<u>Invoice Description</u>	<u>Payment Amount</u>
Remit to: ANAHEIM, CA					<u>FYTD:</u> \$1,434,858.41
ENERGUY	246045	08/16/2023	BOM23-0134	REFUND PERMIT FEES-PROJECT CANCELLED-23823 ROWE DR	\$191.20
	246046	08/16/2023	BOM23-0091	REFUND PERMIT FEES-PROJECT CANCELLED-28590 DORAL WAY	\$191.20
	246047	08/16/2023	BOW23-0089	REFUND PERMIT FEES-PROJECT CANCELLED-25678 JASON PL	\$55.52
	246048	08/16/2023	BOM23-0191	REFUND PERMIT FEES-PROJECT CANCELLED-25678 JASON PL	\$191.20
	246049	08/16/2023	BOM23-0313	REFUND PERMIT FEES-PROJECT CANCELLED-24383 CAROLEE AVE	\$191.20
	246050	08/16/2023	BOP23-0044	REFUND PERMIT FEES-PROJECT CANCELLED-24510 FREEPORT DR	\$191.52
	246118	08/23/2023	BOM23-0068	REFUND PERMIT FEES-PROJECT CANCELLED-13704 CRAPE MYRTLE DR	\$191.20
	246119	08/23/2023	BOM23-0275	REFUND PERMIT FEES-PROJECT CANCELLED-22630 MORALIA DR	\$191.20
Remit to: TEMECULA, CA					<u>FYTD:</u> \$1,394.24
ENTENMANN-ROVIN COMPANY, INC.	245934	08/02/2023	0174800-IN	MORENO VALLEY DOME BADGE'S-CODE ENF	\$526.50
Remit to: LOS ANGELES, CA					<u>FYTD:</u> \$526.50
ENTERPRISE FM TRUST LSR/POLICE DEPT LSE	245954	08/02/2023	MVA020064594	REFUND PARKING CITATION FEE - DISMISSED	\$57.50
Remit to: ORANGE, CA					<u>FYTD:</u> \$57.50
ENTERPRISE SOLUTIONS CONSULTING, LLC	38048	08/09/2023	MVU-2023-07	CONSULTING SERVICE-MV UTILITIES	\$6,000.00
	38154	08/23/2023	MVU-2023-08	CONSULTING SERVICE-MV UTILITIES	\$6,000.00
Remit to: WEBSTER, NY					<u>FYTD:</u> \$12,000.00
ESMAEL , RALPH	246051	08/16/2023	2003505.047	ACCOUNT CREDIT REFUND	\$250.00
Remit to: MORENO VALLEY, CA					<u>FYTD:</u> \$250.00

Attachment: August2023PaymentRegisterSR (6410 : AUGUST PAYMENT REGISTER 2023)



City of Moreno Valley
Payment Register
For Period 8/1/2023 through 8/31/2023

CHECKS UNDER \$25,000

Vendor Name	Check/EFT Number	Payment Date	Inv Number	Invoice Description	Payment Amount
EUBANY, JOY	246052	08/16/2023	MVA020061060	REFUND PARKING CITATION FEE - VIOLATION DISMISSED	\$57.50
Remit to: MORENO VALLEY, CA					FYTD: \$57.50
EXCLUSIVE TOWING	245976	08/09/2023	23-21686	EVIDENCE VEHICLE TOWING-PD	\$281.00
	246005	08/16/2023	23-21428	EVIDENCE VEHICLE TOWING-PD	\$843.00
		08/16/2023	23-21461	EVIDENCE VEHICLE TOWING-PD	
	246099	08/23/2023	23-21836	TRANSPORT VEHICLE TOWING-ELECTRIC WHEELCHAIR-PD	\$281.00
Remit to: RIVERSIDE, CA					FYTD: \$1,686.00
FAITH WORLD HARVEST INC	246120	08/23/2023	2003538; 2003548	DEPOSIT REFUND/AV REFUND- AMPHITHEATER RENTAL	\$1,267.00
Remit to: HEMET, CA					FYTD: \$1,267.00
FERNANDEZ, MARISOL	246121	08/23/2023	R23-173164	ANIMAL SERVICES REFUND S/N DEPOSIT	\$75.00
Remit to: RIVERSIDE, CA					FYTD: \$75.00
FERRELLGAS LP	246006	08/16/2023	2033335784	PROPANE REFILL-FIRE STATION 6	\$427.01
Remit to: DENVER, CO					FYTD: \$427.01
FIGUEROA, MONICA	246053	08/16/2023	MVP99162	REFUND PARKING CITATION FEE - VIOLATION DISMISSED	\$407.50
Remit to: LAKE ELSINORE, CA					FYTD: \$407.50
FIRST AMERICAN DATA TREE, LLC	246007	08/16/2023	20027760723	ONLINE SOFTWARE SUBSCRIPTION-JULY 2023	\$99.00
Remit to: PASADENA, CA					FYTD: \$198.00
FLOCK GROUP INC. DBA FLOCK SAFETY	37981	08/02/2023	INV-16981	CAMERA MAINT-TECH SVCS	\$750.00
	38049	08/09/2023	INV-16121	ADDITIONAL TRIP-TECH SVCS	\$350.00
Remit to: ATLANTA, GA					FYTD: \$496,881.51

Attachment: August2023PaymentRegisterSR (6410 : AUGUST PAYMENT REGISTER 2023)



City of Moreno Valley
Payment Register
 For Period 8/1/2023 through 8/31/2023

CHECKS UNDER \$25,000

<u>Vendor Name</u>	<u>Check/EFT Number</u>	<u>Payment Date</u>	<u>Inv Number</u>	<u>Invoice Description</u>	<u>Payment Amount</u>
FLOGERZI, CRISTINA	246054	08/16/2023	2003506.047	ACCOUNT CREDIT REFUND	\$10.00
Remit to: MORENO VALLEY, CA					<u>FYTD:</u> \$10.00
FM THOMAS AIR CONDITIONING INC	38050	08/09/2023	45545	REPLACED UNDERSIZED DUCTWORK-COTTONWOOD GOLF CENTER	\$4,702.71
Remit to: BREAA, CA					<u>FYTD:</u> \$7,040.94
FRANKLIN, CAMERON	246055	08/16/2023	R23-174819	ANIMAL SERVICES REFUND S/N DEPOSIT	\$75.00
Remit to: REDLANDS, CA					<u>FYTD:</u> \$75.00
FREEDOM FOREVER LLC	246056	08/16/2023	BOE23-0217	REFUND PLANCHECK FEES-REVISIONS PROCESSED INCORRECTLY-16165 ONDA	\$616.00
Remit to: TEMECULA, CA					<u>FYTD:</u> \$616.00
FRIEDMANN-FOLMAN, PATRICIA	245955	08/02/2023	R23-174036	ANIMAL SERVICES REFUND S/N AND RAB DEP	\$95.00
Remit to: SUN CITY, CA					<u>FYTD:</u> \$95.00
FRONTIER COMMUNICATIONS	245977	08/09/2023	062221-5/AUG23	COMMUNICATION SVCS-07/28/23-08/27/23	\$2,399.01
		08/09/2023	062221-5/JUL23	COMMUNICATION SVCS-06/28/23-07/27/23	
		08/23/2023	081095-5/AUG23	FOREIGN EXCHANGE BUS LISTING-MV UTILITY	\$7.13
Remit to: CINCINNATI, OH					<u>FYTD:</u> \$27,882.87
FUEL PROS, INC	38051	08/09/2023	0000069589	DIESEL CLOCK GAUGE REPAIR-FIRE STATION 65	\$261.25
Remit to: CHINO, CA					<u>FYTD:</u> \$261.25
FUENTES, HUMBERTO	245956	08/02/2023	CIT.# C22224	REFUND CITATION OVERPAYMENT	\$100.00
Remit to: MORENO VALLEY, CA					<u>FYTD:</u> \$100.00

Attachment: August2023PaymentRegisterSR (6410 : AUGUST PAYMENT REGISTER 2023)



City of Moreno Valley
Payment Register
For Period 8/1/2023 through 8/31/2023

CHECKS UNDER \$25,000

Vendor Name	Check/EFT Number	Payment Date	Inv Number	Invoice Description	Payment Amount
G3 QUALITY INC	38207	08/30/2023	14438	FREEWAY INSPECTION & REPORT PREP-JULY 2023-MAINT & OP'S	\$3,939.75
Remit to: CERRITOS, CA					FYTD: \$80,042.25
GALLS INC., INLAND UNIFORM	38105	08/16/2023	OR24214993	FIRST DEFENSE SPRAY & CHAIN HOLDER-CODE ENF	\$234.78
	38208	08/30/2023	025184437	KEY RING HOLDER-ANIMAL SVCS	\$1,129.25
		08/30/2023	025315360	TAC LITE PANTS-ANIMAL SVCS	
		08/30/2023	025339382	POLOS FOR ANIMAL CONTROL OFFICERS-ANIMAL SVCS	
Remit to: CHICAGO, IL					FYTD: \$1,364.03
GALVAN, CARLEY	245957	08/02/2023	R23-174800	ANIMAL SERVICES REFUND S/N DEPOSIT	\$75.00
Remit to: MORENO VALLEY, CA					FYTD: \$75.00
GALVAN, LYDIA	246057	08/16/2023	2003507.047	ACCOUNT CREDIT REFUND	\$76.22
Remit to: RIVERSIDE, CA					FYTD: \$76.22
GARCIA, DENISSE	246058	08/16/2023	2003508.047	ACCOUNT CREDIT REFUND	\$67.00
Remit to: LAKE ELSINORE, CA					FYTD: \$67.00
GARCIA, ERIC	246122	08/23/2023	R23-172653	ANIMAL SERVICES REFUND S/N DEPOSIT	\$75.00
Remit to: RIVERSIDE, CA					FYTD: \$75.00
GARCIA, JESSICA	245958	08/02/2023	R23-173956	ANIMAL SERVICES REFUND S/N AND RAB DEP	\$95.00
Remit to: MORENO VALLEY, CA					FYTD: \$95.00

Attachment: August2023PaymentRegisterSR (6410 : AUGUST PAYMENT REGISTER 2023)



**City of Moreno Valley
Payment Register
For Period 8/1/2023 through 8/31/2023**

CHECKS UNDER \$25,000

<u>Vendor Name</u>	<u>Check/EFT Number</u>	<u>Payment Date</u>	<u>Inv Number</u>	<u>Invoice Description</u>	<u>Payment Amount</u>
GARDAWORLD	38106	08/16/2023	10749062	ARMORED CAR SVC-CITY HALL, CONF & REC, MVU, LIBRARY, & ANML SVCS	\$1,019.55
	38209	08/30/2023	10745189	ARMORED CAR SVC-CITY HALL, CONF & REC, MVU, LIBRARY, & ANML SVCS	\$1,196.83
		08/30/2023	20576350	ARMORED CAR SVC-CITY HALL, CONF & REC, & LIBRARY	
Remit to: CHICAGO, IL					FYTD: \$2,438.40
GASKELL TEP LLC	38107	08/16/2023	GW2A06-2023a	DIFF OF RENEWABLE ENERGY - JUNE 2023	\$9,512.87
Remit to: MIAMI, FL					FYTD: \$56,441.45
GILLIS + PANICHAPAN ARCHITECTS, INC.	38210	08/30/2023	108580J	803 0055 CORPORATE YARD OFFICE BUILDING F	\$10,460.00
Remit to: COSTA MESA, CA					FYTD: \$33,192.01
GLOBAL MUSIC RIGHTS, LLC	38211	08/30/2023	INV-GMR-77061	GLOBAL MUSIC RIGHTS LICENSE-05/01/23 TO 4/30/24-MEDIA	\$2,000.00
Remit to: LOS ANGELES, CA					FYTD: \$2,000.00
GODOY GUERRERO, KIMBERLY	246123	08/23/2023	R23-175771	ANIMAL SERVICES REFUND S/N DEPOSIT	\$75.00
Remit to: MORENO VALLEY, CA					FYTD: \$75.00
GOLDEN STAR TECHNOLOGY, DBA: GST	245936	08/02/2023	INV88680	MOBILE DIRECT THERMAL PRINTERS-POLICE	\$8,849.93
		08/02/2023	INV89618	EXTENDED BATTERY FOR TABLET & HAND STRAP-POLICE	
		08/02/2023	INV90590	TABLETS & OFFICE DOCS-POLICE	
Remit to: CERRITOS, CA					FYTD: \$8,849.93
GOMEZ , JESUS MONTOYA HERMIN	246059	08/16/2023	REFUND-8/07/23	REFUND PARKING CITATIONS MVA050020947, MVA010018114 & MVP93508	\$427.50
Remit to: SAN BERNARDINO, CA					FYTD: \$427.50

Attachment: August2023PaymentRegisterSR (6410 : AUGUST PAYMENT REGISTER 2023)



City of Moreno Valley
Payment Register
For Period 8/1/2023 through 8/31/2023

CHECKS UNDER \$25,000

Vendor Name	Check/EFT Number	Payment Date	Inv Number	Invoice Description	Payment Amount
GONZALEZ, RICARDO	246008	08/16/2023	8/6 - 8/9/23	TRAVEL PER DIEM & MILEAGE - TOWER CLIMBER & RESCUE TRAINING CRS	\$316.40
Remit to: MORENO VALLEY, CA					FYTD: \$316.40
GORM INC.	246101	08/23/2023	320727	JANITORIAL SUPPLIES-PARKS MAINT	\$5,061.20
		08/23/2023	320987	JANITORIAL SUPPLIES-PARKS MAINT	
	246151	08/30/2023	318545A	JANITORIAL SUPPLIES-PARKS MAINT	\$2,714.10
		08/30/2023	321684	JANITORIAL SUPPLIES-PARKS MAINT	
Remit to: ONTARIO, CA					FYTD: \$14,000.68
GRANT, KACHERION	246176	08/30/2023	2003594; 2003595	ACTIVITY REFUND- VALLEY DAY CAMP	\$223.76
Remit to: MORENO VALLEY, CA					FYTD: \$223.76
GUERRERO, MIGUEL	246060	08/16/2023	2003509.047	ACCOUNT CREDIT REFUND	\$250.00
Remit to: MORENO VALLEY, CA					FYTD: \$250.00
GUTIERREZ, NANCY	246177	08/30/2023	2003556.047	ACCOUNT CREDIT REFUND	\$30.00
Remit to: MORENO VALLEY, CA					FYTD: \$30.00
HAAKER EQUIPMENT COMPANY DBA TOTAL CLEAN	38213	08/30/2023	W1A47S	FLOOR SCRUBBER PARTS & REPAIRS-ANIMAL SVCS	\$763.14
Remit to: LA VERNE, CA					FYTD: \$763.14
HABITAT FOR HUMANITY RIVERSIDE	37983	08/02/2023	MHR2122 - INV24	MOBILE HOME REPAIR PROGRAM-JUNE 2023	\$11,801.77
Remit to: RIVERSIDE, CA					FYTD: \$61,322.92
HANNAH, BLACHE	246061	08/16/2023	2003478.047	ACCOUNT CREDIT REFUND	\$77.30
Remit to: LOS ANGELES, CA					FYTD: \$77.30

Attachment: August2023PaymentRegisterSR (6410 : AUGUST PAYMENT REGISTER 2023)



City of Moreno Valley
Payment Register
For Period 8/1/2023 through 8/31/2023

CHECKS UNDER \$25,000

Vendor Name	Check/EFT Number	Payment Date	Inv Number	Invoice Description	Payment Amount
HARLAND, DONALD	245959	08/02/2023	RCPT.# 002273	REFUND CHARGE FOR RETURNED LOST LIBRARY BOOK - POWERNOMICS	\$26.93
Remit to: MORENO VALLEY, CA					FYTD: \$26.93
HARRINGTON, ELIZABETH	245960	08/02/2023	R23-175147	ANIMAL SERVICES REFUND S/N DEPOSIT	\$75.00
Remit to: VISTA, CA					FYTD: \$75.00
HARRIS & ASSOCIATES	245978	08/09/2023	58119	CSA 152-NPDES FY23-24 - MAY 2023 - LAND DEV	\$4,493.75
		08/09/2023	58659	CSA 152-NPDES FY23-24 - JUNE 2023 - LAND DEV	
Remit to: CONCORD, CA					FYTD: \$4,493.75
HARRIS, MARKELL	246062	08/16/2023	2003510.047	ACCOUNT CREDIT REFUND	\$250.00
Remit to: MORENO VALLEY, CA					FYTD: \$250.00
HASCO HEATING AIR CONDITIONING SERVICE COMPANY	38214	08/30/2023	CD1474	HVAC REPAIR-FIRE STATION 2	\$926.25
		08/30/2023	JM1116	HVAC REPAIR-FIRE STATION 2	
Remit to: RIVERSIDE, CA					FYTD: \$926.25
HEBERT, ASHLEY	246063	08/16/2023	2003511.047	ACCOUNT CREDIT REFUND	\$123.95
Remit to: MORENO VALLEY, CA					FYTD: \$123.95
HENESEY, SHAUN	246102	08/23/2023	8/8 - 8/9/23	TRAVEL PER DIEM - TOBACCO TASK FORCE TRAINING	\$103.50
Remit to: MORENO VALLEY, CA					FYTD: \$103.50
HERNANDEZ, SALLY	246064	08/16/2023	2003483.047	ACCOUNT CREDIT REFUND	\$47.00
Remit to: MORENO VALLEY, CA					FYTD: \$47.00

Attachment: August2023PaymentRegisterSR (6410 : AUGUST PAYMENT REGISTER 2023)



City of Moreno Valley
Payment Register
For Period 8/1/2023 through 8/31/2023

CHECKS UNDER \$25,000

Vendor Name	Check/EFT Number	Payment Date	Inv Number	Invoice Description	Payment Amount
HLP, INC.	38109	08/16/2023	190408	WEB LICENSE MONTHLY SVC FEE-ANIMAL SVCS	\$59.15
Remit to: LITTLETON, CO					FYTD: \$126.35
HODNETT, ELESOVA	246065	08/16/2023	R23-175765	ANIMAL SERVICES REFUND LICENSE OVERPAY	\$20.00
Remit to: MORENO VALLEY, CA					FYTD: \$20.00
HORN, JEANETTE	246178	08/30/2023	R23-175231	ANIMAL SERVICES REFUND S/N DEPOSIT	\$75.00
Remit to: HEMET, CA					FYTD: \$75.00
HUNSAKER & ASSOCIATES IRVINE, INC	38054	08/09/2023	23060413	PLAN CHECK SVCS-BRADSHAW MAJESTIC-JUNE 2023	\$864.00
	38110	08/16/2023	23060411	PLAN CHECK SVCS-TR33607 IRIS PEN19-0203-JUNE 2023	\$19,179.15
		08/16/2023	23060414	PLAN CHECK SVCS-BRADSHAW-JUNE 2023	
		08/16/2023	23060416	PLAN CHECK SVCS-TR 37725/PEN21-0206-JUNE 2023	
Remit to: IRVINE, CA					FYTD: \$20,043.15
HUNTER CONSULTING INC. DBA HCI ENVIRONMENTAL & ENG	38111	08/16/2023	36618	HAZARDOUS WASTE OIL REMOVAL FOR FLEET-CITY YARD	\$1,928.74
Remit to: CORONA, CA					FYTD: \$1,928.74
HUNTER, BILIALAN	38215	08/30/2023	FINALWAGEPO82323	PAYOUT OF ADDTL. LEAVE FOUND AFTER REVIEW-EMP #700203 (H. BOWIE)	\$111.44
Remit to: PUYALLUP, WA					FYTD: \$111.44
IBOSS, INC.	38157	08/23/2023	962862-95000	IBOSS ENTERPRISE UPGRADE PACKAGE-TECH SVCS	\$10,884.62
		08/23/2023	974035-104632	SUBSCRIPTION DEBOOKING CREDIT-TECH SVCS	
Remit to: BOSTON, MA					FYTD: \$10,884.62

Attachment: August2023PaymentRegisterSR (6410 : AUGUST PAYMENT REGISTER 2023)



City of Moreno Valley
Payment Register
 For Period 8/1/2023 through 8/31/2023

CHECKS UNDER \$25,000

<u>Vendor Name</u>	<u>Check/EFT Number</u>	<u>Payment Date</u>	<u>Inv Number</u>	<u>Invoice Description</u>	<u>Payment Amount</u>
IMEG CONSULTANTS CORP	38112	08/16/2023	20001409.00-9	HVAC SYSTEM REPLACEMENT-JUL.23-PUBLIC SAFETY BLDG.	\$1,576.00
Remit to: ROCK ISLAND, IL					<u>FYTD:</u> \$1,576.00
INLAND ELECTRIC INC.	37985	08/02/2023	6201	TOWNGATE MEMORIAL PARK WALKWAY LED RETRO-PARKS	\$5,698.50
Remit to: RIVERSIDE, CA					<u>FYTD:</u> \$9,287.50
INLAND EMPIRE PROPERTY SERVICE, INC	37986	08/02/2023	40127	NUISANCE ABATEMENT SVCS-APN 473-160-007-FIRE PREV	\$11,474.00
		08/02/2023	40128	NUISANCE ABATEMENT SVCS-APN 478-090-027-FIRE PREV	
		08/02/2023	40129	NUISANCE ABATEMENT SVCS-APN 481-041-028-FIRE PREV	
		08/02/2023	40130	NUISANCE ABATEMENT SVCS-APN 485-220-041-FIRE PREV	
	38216	08/30/2023	2023208	WEED ABATEMENT SVCS-POORMANS RESVR-PARKS MAINT	\$17,001.00
		08/30/2023	2023209	WEED ABATEMENT SVCS-EQUESTRIAN CTR-PARKS MAINT	
		08/30/2023	2023210	WEED ABATEMENT SVCS-APN 259-240-084-PARKS MAINT	
Remit to: MORENO VALLEY, CA					<u>FYTD:</u> \$70,365.00
INTER-CITY ENERGY SYSTEMS	246124	08/23/2023	BOM22-0222	REFUND PERMIT FEES-PROJECT CANCELLED-25590 BLACK WALNUT ST	\$191.20
	246125	08/23/2023	BOM23-0251	REFUND PERMIT FEES-PROJECT CANCELLED-14584 CAGNEY CT	\$191.20
	246126	08/23/2023	BOM23-0198	REFUND PERMIT FEES-PROJECT CANCELLED-12539 PENSKE ST	\$191.20
	246127	08/23/2023	BOM22-0638	REFUND PERMIT FEES-PROJECT CANCELLED-25474 WEDMORE DR	\$191.20
Remit to: ONTARIO, CA					<u>FYTD:</u> \$764.80

Attachment: August2023PaymentRegisterSR (6410 : AUGUST PAYMENT REGISTER 2023)



**City of Moreno Valley
Payment Register
For Period 8/1/2023 through 8/31/2023**

CHECKS UNDER \$25,000

<u>Vendor Name</u>	<u>Check/EFT Number</u>	<u>Payment Date</u>	<u>Inv Number</u>	<u>Invoice Description</u>	<u>Payment Amount</u>
INTERWEST CONSULTING GROUP, INC.	37987	08/02/2023	88721	PLAN CHECK SVCS-PEN22-0088/CHASE MV BUS CTR-MAY 2023	\$9,170.00
		08/02/2023	88725	PLAN CHECK SVCS-TR38123/DR HORTON-MAY 2023	
		08/02/2023	88726	PLAN CHECK SVCS-TR38123/DR HORTON-MAY 2023	
		08/02/2023	88727	PLAN CHECK SVCS-TR38123/DR HORTON-MAY 2023	
		08/02/2023	89288	PLAN CHECK SVCS-TR38123/DR HORTON-JUNE 2023	
		08/02/2023	89292	PLAN CHECK SVCS-TR38123/DR HORTON-JUNE 2023	
Remit to: LOVELAND, CO					<u>FYTD:</u> \$31,150.00
IPERMIT	246066	08/16/2023	BOM23-0307	REFUND PERMIT FEES-PROJECT CANCELLED-25152 FAY AVE	\$191.20
Remit to: WESTLAKE VILLAGE, CA					<u>FYTD:</u> \$191.20
ISLAND, ASHTYN	246067	08/16/2023	2003527.047	ACCOUNT CREDIT REFUND	\$171.84
Remit to: PERRIS, CA					<u>FYTD:</u> \$171.84
JACOBS ENGINEERING GROUP, INC.	38217	08/30/2023	W9Y51100-06	808 0004 TRAFFIC SIGNAL COORDINATION PROGRAM	\$2,500.00
Remit to: DALLAS, TX					<u>FYTD:</u> \$21,000.00
JACOBS, GLENN	246068	08/16/2023	2003512.047	ACCOUNT CREDIT REFUND	\$300.00
Remit to: MORENO VALLEY, CA					<u>FYTD:</u> \$300.00
JIMENEZ, CLEMENT	246152	08/30/2023	9/5 - 9/7/23	TRAVEL PER DIEM & MILEAGE - 2023 FMA ANNUAL CONFERENCE	\$204.26
Remit to: MORENO VALLEY, CA					<u>FYTD:</u> \$204.26
JOHNSON , TRACY	38218	08/30/2023	JUL. 2023	INSTRUCTOR SERVICES - SHITO-RYU KARATE CLASSES	\$547.20
Remit to: MORENO VALLEY, CA					<u>FYTD:</u> \$1,003.20

Attachment: August2023PaymentRegisterSR (6410 : AUGUST PAYMENT REGISTER 2023)



**City of Moreno Valley
Payment Register
For Period 8/1/2023 through 8/31/2023**

CHECKS UNDER \$25,000

<u>Vendor Name</u>	<u>Check/EFT Number</u>	<u>Payment Date</u>	<u>Inv Number</u>	<u>Invoice Description</u>	<u>Payment Amount</u>
JOHNSON, KIA	246069	08/16/2023	2003513.047	ACCOUNT CREDIT REFUND	\$67.00
Remit to: MORENO VALLEY, CA					<u>FYTD:</u> \$67.00
JOSEPH M. BAKER JR. DBA SPORTIQUE SCREEN PRINTING	38056	08/09/2023	53600	BEAUTIFY MOVAL PROGRAM T-SHIRTS	\$731.67
Remit to: RIVERSIDE, CA					<u>FYTD:</u> \$4,322.92
JTB SUPPLY CO., INC.	38158	08/23/2023	112348	TRAFFIC SIGNAL MAINT SUPPLIES	\$5,387.50
Remit to: ORANGE, CA					<u>FYTD:</u> \$8,864.39
KB HOME INLAND EMPIRE	245962	08/02/2023	PA12-0005 REFUND	REFUND PARKS TRAIL DEPOSIT FOR PROJECT PA12-0005 (TR 36436)	\$10,000.00
Remit to: WILDOMAR, CA					<u>FYTD:</u> \$10,000.00
KINGDOM DEVELOPMENT INC.	245963	08/02/2023	PROJ. PEN19-0110	REFUND EROSION CTRL SECURITY DEPOSIT-COURTYARDS AT COTTONWOOD	\$10,262.50
Remit to: RIVERSIDE, CA					<u>FYTD:</u> \$10,262.50
KONICA MINOLTA BUSINESS SOLUTIONS, USA	37988	08/02/2023	42690300	COPIER LEASE-CITY WIDE-JUNE 2023	\$13,039.44
		08/02/2023	42690301	COPIERS C650I/C550I/BIZ360I-CITY WIDE	
Remit to: PASADENA, CA					<u>FYTD:</u> \$13,039.44
KRASNAK, NATHAN	246070	08/16/2023	2003514.047	ACCOUNT CREDIT REFUND	\$150.00
Remit to: MORENO VALLEY, CA					<u>FYTD:</u> \$150.00
KUSTOM SIGNALS, INC.	246009	08/16/2023	604730	RADAR/LASER MAINT & REPAIR-POLICE DEPT	\$546.95
Remit to: CHARLOTTE, NC					<u>FYTD:</u> \$827.68

Attachment: August2023PaymentRegisterSR (6410 : AUGUST PAYMENT REGISTER 2023)



**City of Moreno Valley
Payment Register
For Period 8/1/2023 through 8/31/2023**

CHECKS UNDER \$25,000

<u>Vendor Name</u>	<u>Check/EFT Number</u>	<u>Payment Date</u>	<u>Inv Number</u>	<u>Invoice Description</u>	<u>Payment Amount</u>
Remit to: VISALIA, CA					FYTD: \$1,049.68
KUUBIX GLOBAL LLC	246179	08/30/2023	BON22-1449	REFUND PERMIT FEES-PERMIT CANCELLED-12330 LOREZ DR	\$140.56
	246180	08/30/2023	BOE22-0498	REFUND PERMIT FEES-PERMIT CANCELLED-11523 PROSPERITY LN	\$191.52
	246181	08/30/2023	BOE22-0637	REFUND PERMIT FEES-PERMIT CANCELLED-22638 MORALIA DR	\$191.52
	246182	08/30/2023	BON22-1685	REFUND PERMIT FEES-PERMIT CANCELLED-22638 MORALIA DR	\$263.04
	246183	08/30/2023	BON23-1330	REFUND PERMIT FEES-PERMIT CANCELLED-21110 DICKINSON RD	\$263.04
LEADERSHIP MILITARY ACADEMY	246071	08/16/2023	2003523.047	ACCOUNT CREDIT REFUND	\$57.00
Remit to: MORENO VALLEY, CA					FYTD: \$57.00
LEIGHTON CONSULTING, INC.	37990	08/02/2023	57737	801 0021 SR60/MORENO BEACH PH 2	\$9,856.44
Remit to: IRVINE, CA					FYTD: \$28,550.12
LENHAUSEN, CYNTHIA	245964	08/02/2023	CIT.# C32263	REFUND ADMIN CITATION FEE - DISMISSED	\$2,000.00
Remit to: MORENO VALLEY, CA					FYTD: \$2,000.00
LEXISNEXIS PRACTICE MANAGEMENT	38113	08/16/2023	3094637109	LEGAL RESEARCH TOOLS-JULY 2023	\$883.20
Remit to: CHICAGO, IL					FYTD: \$1,766.40
LIEBERT, CASSIDY, WHITMORE	245937	08/02/2023	244687	LEGAL SERVICES-MO140-00018-HUMAN RESOURCES	\$1,808.28
Remit to: LOS ANGELES, CA					FYTD: \$4,038.11
LOR GEOTECHNICAL GROUP, INC.	37991	08/02/2023	19139	801 0089 CITYWIDE PVT REHAB FY 21/22	\$6,545.90
		08/02/2023	19144	VARIOUS LOCAL STREETS_FINAL REPORT	
		08/02/2023	19164	801 0087 CITYWIDE PVMT REHAB PGM FY20/21	
	38219	08/30/2023	19180	801 0089 CITYWIDE PVT REHAB FY 21/22	\$2,138.60
Remit to: RIVERSIDE, CA					FYTD: \$8,684.50

Attachment: August2023PaymentRegisterSR (6410 : AUGUST PAYMENT REGISTER 2023)



City of Moreno Valley
Payment Register
For Period 8/1/2023 through 8/31/2023

CHECKS UNDER \$25,000

Vendor Name	Check/EFT Number	Payment Date	Inv Number	Invoice Description	Payment Amount
LYNCHESKI, MARC	246154	08/30/2023	2023.7.1.2	COMMUNICATION SERVICES 7/08-8/17/23	\$1,592.50
Remit to: TUSTIN, CA					FYTD: \$9,742.50
LYONS SECURITY SERVICE, INC.	37992	08/02/2023	35587	SECURITY GUARD SVCS-COMMUNITY PARK-JUNE 2023	\$5,621.71
		08/02/2023	35590	SECURITY GUARD SVCS-COTTONWOOD SPCL EVENTS-JUNE 2023	
		08/02/2023	35595	SECURITY GUARD SVCS-SENIOR CENTER-JUNE 2023	
		08/02/2023	35596	SECURITY GUARD SVCS-TOWNGATE-JUNE 2023	
	38058	08/09/2023	35588	SECURITY GUARD SVCS-CITY HALL-JUNE 2023	\$24,417.83
		08/09/2023	35589	SECURITY GUARD SVCS-CITY YARD-JUNE 2023	
		08/09/2023	35593	SECURITY GUARD SVCS-ERC-JUNE 2023	
		08/09/2023	35594	SECURITY GUARD SVCS-LIBRARY-JUNE 2023	
	38115	08/16/2023	35800	SECURITY GUARD SVCS-CITY HALL-JULY 2023	\$14,214.60
		08/16/2023	35805	SECURITY GUARD SVCS-ERC-JULY 2023	
		08/16/2023	35806	SECURITY GUARD SVCS-LIBRARY-JULY 2023	
		08/16/2023	35807	SENIOR CENTER EVENT-PARKS	
	38159	08/23/2023	35592	SECURITY GUARD SVCS-CONF & REC CTR EVENTS-JUNE 2023	\$14,350.43
		08/23/2023	35804	SECURITY GUARD SVCS-CONF & REC CTR EVENTS-JULY 2023	
		08/23/2023	35809	SECURITY GUARD SVCS-4TH OF JULY EVENT-PARKS	
	38220	08/30/2023	35801	SECURITY GUARD SVCS-CITY YARD-JULY 2023	\$10,780.19
Remit to: ANAHEIM, CA					FYTD: \$78,560.18
M & J ENTERPRISES INC. DBA TRAVELING TIDE POOLS	245938	08/02/2023	061723	JOLLY JUMPS - PARKS	\$1,335.00
Remit to: MURRIETA, CA					FYTD: \$1,335.00
MACIEL, LAUREN	246072	08/16/2023	2003515.047	ACCOUNT CREDIT REFUND	\$150.00
Remit to: MORENO VALLEY, CA					FYTD: \$150.00

Attachment: August2023PaymentRegisterSR (6410 : AUGUST PAYMENT REGISTER 2023)



**City of Moreno Valley
Payment Register
For Period 8/1/2023 through 8/31/2023**

CHECKS UNDER \$25,000

<u>Vendor Name</u>	<u>Check/EFT Number</u>	<u>Payment Date</u>	<u>Inv Number</u>	<u>Invoice Description</u>	<u>Payment Amount</u>
MAGEE, GREGORY	246073	08/16/2023	2003528.047	ACCOUNT CREDIT REFUND	\$200.00
Remit to: MORENO VALLEY, CA					<u>FYTD:</u> \$200.00
MALCOLM SMITH MOTORCYCLES, INC.	38059	08/09/2023	100822303	BOOTS & GLOVES FOR PD MOTOR OFFICERS	\$327.19
Remit to: RIVERSIDE, CA					<u>FYTD:</u> \$327.19
MARCH JOINT POWERS AUTHORITY	245939	08/02/2023	59825	GAS CHARGES-M.A.R.B. BUILDING 823-APR. 2023	\$104.79
		08/02/2023	59828	GAS CHARGES-M.A.R.B. BUILDING 938-APR. 2023	
Remit to: RIVERSIDE, CA					<u>FYTD:</u> \$104.79
MAR-CO EQUIPMENT COMPANY	38221	08/30/2023	195301	STREET SWEEPER REPAIR - LABOR & PARTS	\$23,418.22
		08/30/2023	195383	STREET SWEEPER REPAIR - LABOR & PARTS	
Remit to: POMONA, CA					<u>FYTD:</u> \$23,418.22
MARGARITAS GRILL RESTAURANT & CATERING, LLC	37994	08/02/2023	S02507	VIP CATERING FOR 4TH OF JULY 2023 EVENT	\$9,490.62
Remit to: MORENO VALLEY, CA					<u>FYTD:</u> \$9,490.62
MARIACHI DIVAS, INC.	245965	08/02/2023	10052	MARIACHI DIVAS MUSIC PERFORMANCE FOR M.V. SUMMER CONCERT-8/3/23	\$3,000.00
Remit to: HACIENDA HEIGHTS, CA					<u>FYTD:</u> \$3,000.00
MARIANA, RODRIGUEZ	246074	08/16/2023	2003522.047	ACCOUNT CREDIT REFUND	\$37.60
Remit to: MURRIETA, CA					<u>FYTD:</u> \$37.60

Attachment: August2023PaymentRegisterSR (6410 : AUGUST PAYMENT REGISTER 2023)



**City of Moreno Valley
Payment Register
For Period 8/1/2023 through 8/31/2023**

CHECKS UNDER \$25,000

<u>Vendor Name</u>	<u>Check/EFT Number</u>	<u>Payment Date</u>	<u>Inv Number</u>	<u>Invoice Description</u>	<u>Payment Amount</u>
MARIPOSA LANDSCAPES, INC.	37995	08/02/2023	103248	LANDSCAPE MAINT.-MORENO BEACH ELECTRIC SUBSTATION-JUN. 2023	\$699.76
		08/02/2023	103252	LANDSCAPE MAINT.-UTILITY FIELD OFFICE-JUN. 2023	
		08/02/2023	103258	LANDSCAPE MAINT.-KITCHING ELECTRIC SUBSTATION-JUN. 2023	
	38222	08/30/2023	103586	SD LANDSCAPE BASE (WQB) JULY	\$7,432.62
Remit to: IRWINDALE, CA					FYTD: \$96,196.36
MARTINEZ, ERNESTO	246128	08/23/2023	R23-175784	ANIMAL SERVICES REFUND LICENSE OVERPAY	\$7.00
Remit to: MORENO VALLEY, CA					FYTD: \$7.00
MARTINEZ, HUGO CANO	245995	08/09/2023	24645 LaBarca MV	REFUND FOR PAYMENT OF WA 40-545B (24645 LABARCA, MORENO VALLEY)	\$1,912.49
Remit to: MORENO VALLEY, CA					FYTD: \$1,912.49
MARTINEZ, JAILYN	246129	08/23/2023	R23-175451	ANIMAL SERVICES REFUND LICENSE OVERPAY	\$13.00
Remit to: MORENO VALLEY, CA					FYTD: \$13.00
MARTINEZ-LANGENBAU, CHRISTOPHER	246075	08/16/2023	2003516.047	ACCOUNT CREDIT REFUND	\$67.00
Remit to: MORENO VALLEY, CA					FYTD: \$67.00
MARX OKUBO ASSOCIATES, LTD	38161	08/23/2023	I-64385-N3Z3	PROPERTY CONDITION ASSESSMENT PROGRESS PAYMENT #2	\$20,986.57
Remit to: DENVER, CO					FYTD: \$90,085.61
MATTOX, JOSEPH	38162	08/23/2023	8/26 - 8/30/23	TRAVEL PER DIEM - 2023 APWA PWX EXPO	\$333.00
Remit to: MORENO VALLEY, CA					FYTD: \$333.00

Attachment: August2023PaymentRegisterSR (6410 : AUGUST PAYMENT REGISTER 2023)



City of Moreno Valley
Payment Register
For Period 8/1/2023 through 8/31/2023

CHECKS UNDER \$25,000

<u>Vendor Name</u>	<u>Check/EFT Number</u>	<u>Payment Date</u>	<u>Inv Number</u>	<u>Invoice Description</u>	<u>Payment Amount</u>
MCGRATH RENTCORP AND SUBSIDIARIES	37996	08/02/2023	301143166	TEMPORARY STORAGE UNIT RENTAL-CITY YARD 07/26-08/24/23	\$197.81
Remit to: SAN FRANCISCO, CA					<u>FYTD:</u> \$395.62
MCT TECHNOLOGY, INC.	246155	08/30/2023	12797	CARE CONNECT - CHILD CARE DATA MANAGEMENT SOFTWARE	\$3,240.00
Remit to: CHINO HILLS, CA					<u>FYTD:</u> \$3,240.00
MEDINA, DANNY	246076	08/16/2023	2003529.047	ACCOUNT CREDIT REFUND	\$0.40
Remit to: MORENO VALLEY, CA					<u>FYTD:</u> \$0.40
MEJIA-NUNEZ, MELANIE	246130	08/23/2023	R23-173554	ANIMAL SERVICES REFUND S/N DEPOSIT	\$75.00
Remit to: MORENO VALLEY, CA					<u>FYTD:</u> \$75.00
MENDOZA, ORLANDO	246131	08/23/2023	R23-175068	ANIMAL SERVICES REFUND LICENSE OVERPAY	\$33.00
Remit to: MORENO VALLEY, CA					<u>FYTD:</u> \$33.00
MERCADO, PRISCILLA	246103	08/23/2023	8/8 - 8/9/23	TRAVEL PER DIEM - TOBACCO TASK FORCE TRAINING	\$103.50
Remit to: MORENO VALLEY, CA					<u>FYTD:</u> \$103.50

Attachment: August2023PaymentRegisterSR (6410 : AUGUST PAYMENT REGISTER 2023)



City of Moreno Valley
Payment Register
For Period 8/1/2023 through 8/31/2023

CHECKS UNDER \$25,000

Vendor Name	Check/EFT Number	Payment Date	Inv Number	Invoice Description	Payment Amount
MERCHANTS BUILDING MAINTENANCE, LLC.	37997	08/02/2023	750293	ANIMAL SHELTER AIR VENTS QUARTERLY CLEANING-COMPLETED 7/16/23	\$1,846.33
	38117	08/16/2023	747422	JUN 2023 SPECIAL CLEANINGS FOR EVENT RENTALS-CONF. & REC. CENTER	\$5,302.06
		08/16/2023	752838	JULY 2023 SPECIAL CLEANING FOR EVENT RENTAL-SENIOR CENTER	
		08/16/2023	752888	JUL 2023 SPECIAL CLEANINGS FOR EVENT RENTALS-COTTONWOOD GOLF CTR	
		08/16/2023	752889	JUL 2023 SPECIAL CLEANINGS FOR EVENT RENTALS-TOWNGATE COMM. CTR.	
Remit to: MONTEREY PARK, CA					FYTD: \$92,848.19
MIDWEST VETERINARY SUPPLY	38061	08/09/2023	19976859-000	ANIMAL MEDICAL SUPPLIES/VACCINES	\$1,136.30
		08/09/2023	20005586-100	ANIMAL MEDICAL SUPPLIES/VACCINES	
	38118	08/16/2023	20005586-050	ANIMAL MEDICAL SUPPLIES/VACCINES	\$802.40
		08/16/2023	20127661-000	ANIMAL MEDICAL SUPPLIES/VACCINES	
Remit to: LAKEVILLE, MN					FYTD: \$3,604.36
MILHOLLAND ELECTRIC, INC	246132	08/23/2023	BON22-2288	REFUND PERMIT FEES-PROJECT CANCELLED-12145 LEIF ERICSON DR	\$263.04
Remit to: EL CAJON, CA					FYTD: \$263.04
MILLER, SHANNON	246184	08/30/2023	R23-175925	ANIMAL SERVICES REFUND S/N AND RAB DEP	\$95.00
Remit to: FALLON, NV					FYTD: \$95.00
MORENO VALLEY COMMUNITY VET CARE	38163	08/23/2023	JUL. 2023	VETERINARY SERVICES-MV ANIMAL SHELTER/JULY 2023	\$24,871.04
Remit to: MORENO VALLEY, CA					FYTD: \$48,591.73

Attachment: August2023PaymentRegisterSR (6410 : AUGUST PAYMENT REGISTER 2023)



**City of Moreno Valley
Payment Register
For Period 8/1/2023 through 8/31/2023**

CHECKS UNDER \$25,000

<u>Vendor Name</u>	<u>Check/EFT Number</u>	<u>Payment Date</u>	<u>Inv Number</u>	<u>Invoice Description</u>	<u>Payment Amount</u>
MORENO VALLEY DIAMOND GIRLS SOFTBALL ASSOCIATION	246010	08/16/2023	AUG 2, 2023	DIST. 3 COUNCIL MEMBER SPONSORSHIP - MVDGSA TEAM: ICE QUEENS	\$500.00
	246011	08/16/2023	AUG. 2, 2023	DIST. 1 COUNCIL MEMBER SPONSORSHIP - MVDGSA TEAM: QUEEN KOBRAS	\$250.00
	246012	08/16/2023	AUG. 7, 2023	DIST. 4 COUNCIL MEMBER SPONSORSHIP - TEAM: ICE QUEENS (8U DIV.)	\$200.00
	246013	08/16/2023	AUG. 8, 2023	DIST. 1 COUNCIL MEMBER SPONSORSHIP - TEAM: CYCLONES (DIV. 3/4)	\$300.00
	246104	08/23/2023	AUG. 16, 2023	DIST. 4 COUNCIL MEMBER SPONSORSHIP - TEAM: CYCLONES (DIV. 3/4)	\$200.00
Remit to: MORENO VALLEY, CA					FYTD: \$1,450.00
MORENO VALLEY FRIENDS OF THE LIBRARY	38223	08/30/2023	JULY 2023	PASS THROUGH FUNDS 7/1-7/31/23	\$972.95
Remit to: MORENO VALLEY, CA					FYTD: \$2,193.80
MORENO VALLEY HISPANIC CHAMBER OF COMMER	246156	08/30/2023	001010	ANNUAL PLATINUM MEMBERSHIP/BENEFITS - FY 23/24	\$15,000.00
Remit to: MORENO VALLEY, CA					FYTD: \$15,000.00
MORENO VALLEY MALL HOLDING, LLC	37998	08/02/2023	AUG. 2023 RENT	AUGUST 2023 RENT PAYMENT FOR SP. 2078-M.V. LIBRARY BRANCH	\$6,874.54
	38224	08/30/2023	SEP. 2023 RENT	SEPTEMBER 2023 RENT PAYMENT FOR SP. 2078-M.V. LIBRARY BRANCH	\$6,874.54
Remit to: MORENO VALLEY, CA					FYTD: \$13,749.08
MOTOPOST USA	246105	08/23/2023	1136	UNIFORM ITEMS FOR PD TRAFFIC OFFICER	\$1,568.02
		08/23/2023	1191	UNIFORM ITEMS FOR PD TRAFFIC OFFICER	
Remit to: ESCONDIDO, CA					FYTD: \$1,568.02

Attachment: August2023PaymentRegisterSR (6410 : AUGUST PAYMENT REGISTER 2023)



City of Moreno Valley
Payment Register
For Period 8/1/2023 through 8/31/2023

CHECKS UNDER \$25,000

Vendor Name	Check/EFT Number	Payment Date	Inv Number	Invoice Description	Payment Amount
MOVAL ELITE ATHLETICS	246077	08/16/2023	2003536.047	ACCOUNT CREDIT REFUND	\$116.00
Remit to: MORENO VALLEY, CA					FYTD: \$116.00
NAMEKATA, JAMES	38225	08/30/2023	JUL. 2023	INSTRUCTOR SERVICES - SHITO-RYU KARATE CLASSES	\$547.20
Remit to: RIVERSIDE, CA					FYTD: \$1,003.20
NARCISSE, MARK	246185	08/30/2023	MVP91437	REFUND PARKING CITATION FEE PAID TWICE (DMV & FTB INTERCEPT)	\$433.00
Remit to: MORENO VALLEY, CA					FYTD: \$433.00
NFL FLAG INLAND EMPIRE	246078	08/16/2023	2003537.047	ACCOUNT CREDIT REFUND	\$20.50
Remit to: EAST HIGHLAND, CA					FYTD: \$20.50
NGUYEN, CLEMENT BA DUONG	38164	08/23/2023	JULY 2023	INSTRUCTOR SERVICES - VOVINAM MARTIAL ARTS CLASSES	\$441.00
Remit to: BEAUMONT, CA					FYTD: \$1,087.80
NGUYEN, HOANG	246157	08/30/2023	9/5 - 9/7/23	TRAVEL PER DIEM & MILEAGE - 2023 FMA ANNUAL CONFERENCE	\$272.38
Remit to: MORENO VALLEY, CA					FYTD: \$272.38
NINYO & MOORE GEOTECHNICAL	38062	08/09/2023	275324	807 0058 PUMP TRACK AT MARCH FIELD PARK	\$4,233.75
Remit to: SAN DIEGO, CA					FYTD: \$4,233.75
NISSAN, CHRISTOPHER	245991	08/09/2023	MVA030029000	REFUND PARKING CITATION FEE - VIOLATION DISMISSED	\$57.50
Remit to: DIAMOND BAR, CA					FYTD: \$57.50

Attachment: August2023PaymentRegisterSR (6410 : AUGUST PAYMENT REGISTER 2023)



**City of Moreno Valley
Payment Register
For Period 8/1/2023 through 8/31/2023**

CHECKS UNDER \$25,000

<u>Vendor Name</u>	<u>Check/EFT Number</u>	<u>Payment Date</u>	<u>Inv Number</u>	<u>Invoice Description</u>	<u>Payment Amount</u>
NPG INC, DBA GOLDSTAR ASPHALT PRODUCTS	38165	08/23/2023	24082	ROAD AND HIGHWAY BUILDING MATERIALS-MAINT & OPS	\$242.98
	38226	08/30/2023	23672	ROAD AND HIGHWAY BUILDING MATERIALS-MAINT & OPS	\$705.23
		08/30/2023	23978	ROAD AND HIGHWAY BUILDING MATERIALS-MAINT & OPS	
		08/30/2023	24198	ROAD AND HIGHWAY BUILDING MATERIALS-MAINT & OPS	
Remit to: PERRIS, CA					<u>FYTD:</u> \$948.21
OJEDA, CYNTHIA	245992	08/09/2023	MVA030029482	REFUND PARKING CITATION FEE PAID AT DMV, AFTER IT WAS MAILED IN.	\$115.00
Remit to: MORENO VALLEY, CA					<u>FYTD:</u> \$115.00
ONNEKIKAM, FRANCIS	246079	08/16/2023	MVA050029308	REFUND PARKING CITATION FEE - DISMISSED	\$115.00
Remit to: VICTORVILLE, CA					<u>FYTD:</u> \$115.00
OPERATION SAFEHOUSE, INC.	37999	08/02/2023	12 - (JUNE 2023)	CDBG SUBRECIPIENT PAYMENT-EMERGENCY SHELTER FOR YOUTH PROGRAM	\$1,560.00
Remit to: RIVERSIDE, CA					<u>FYTD:</u> \$4,120.00
OUTLAW DOGS RESCUE	245993	08/09/2023	R23-175493	ANIMAL SERVICES REFUND UNALTERED FEES	\$65.00
Remit to: SANTA ANA, CA					<u>FYTD:</u> \$65.00
OVIEDO, JUAN	246133	08/23/2023	R23-175928	ANIMAL SERVICES REFUND RAB DEP	\$20.00
Remit to: BLOOMINGTON, CA					<u>FYTD:</u> \$20.00
PACIFC VIEW CHARTER SCHOOL	246080	08/16/2023	2003533.047	ACCOUNT CREDIT REFUND	\$40.50
Remit to: MORENO VALLEY, CA					<u>FYTD:</u> \$40.50
PACIFIC SAFETY CENTER	246093	08/16/2023	83859	HAZWOPER 4-HOUR REFRESHER TRAINING CLASS 3/14/23	\$895.00
Remit to: SAN DIEGO, CA					<u>FYTD:</u> \$895.00

Attachment: August2023PaymentRegisterSR (6410 : AUGUST PAYMENT REGISTER 2023)



City of Moreno Valley
Payment Register
 For Period 8/1/2023 through 8/31/2023

CHECKS UNDER \$25,000

<u>Vendor Name</u>	<u>Check/EFT Number</u>	<u>Payment Date</u>	<u>Inv Number</u>	<u>Invoice Description</u>	<u>Payment Amount</u>
PARSONS TRANSPORTATION GROUP, INC.	38227	08/30/2023	2308A204	801 0021 SR60/MORENO BEACH PH 2	\$3,110.62
Remit to: IRVINE, CA					FYTD: \$5,038.57
PEPE'S TOWING	38063	08/09/2023	107520	EVIDENCE TOWING FOR PD	\$281.00
	38064	08/09/2023	108341	EMERGENCY TOWING SERVICES FOR FLEET VEHICLE	\$550.00
	38119	08/16/2023	111826	EMERGENCY TOWING SERVICES FOR FLEET VEHICLE	\$531.00
		08/16/2023	111858	EVIDENCE TOWING FOR PD	
	38228	08/30/2023	105097	EVIDENCE TOWING FOR PD	\$281.00
Remit to: MORENO VALLEY, CA					FYTD: \$1,643.00
PERCEPTIVE ENTERPRISES, INC.	38229	08/30/2023	3856	PROFESSIONAL DBE/CPR CONSULTING SERVICES	\$9,000.00
Remit to: LOS ANGELES, CA					FYTD: \$17,834.00
PERMIT RUNNER	246186	08/30/2023	BOW22-0280	REFUND PERMIT FEES-PERMIT CANCELLED-25251 ALESSANDRO	\$137.12
	246187	08/30/2023	BOW22-0281	REFUND PERMIT FEES-PERMIT CANCELLED-25299 ALESSANDRO	\$55.52
	246188	08/30/2023	BOW22-0282	REFUND PERMIT FEES-PERMIT CANCELLED-25371 ALESSANDRO	\$55.52
	246189	08/30/2023	BOW22-0290	REFUND PERMIT FEES-PERMIT CANCELLED-25445 ALESSANDRO	\$55.52
	246190	08/30/2023	BOW22-0283	REFUND PERMIT FEES-PERMIT CANCELLED-25407 ALESSANDRO	\$259.52
	246191	08/30/2023	BOW22-0284	REFUND PERMIT FEES-PERMIT CANCELLED-25383 ALESSANDRO	\$177.92
	246192	08/30/2023	BOW22-0285	REFUND PERMIT FEES-PERMIT CANCELLED-25275 ALESSANDRO	\$177.92
	246193	08/30/2023	BOW22-0286	REFUND PERMIT FEE-PERMIT CANCELLED-25323 ALESSANDRO	\$177.92
	246194	08/30/2023	BOW22-0287	REFUND PERMIT FEES-PERMIT CANCELLED-25395 ALESSANDRO	\$177.92
	246195	08/30/2023	BOW22-0288	REFUND PERMIT FEES-PERMIT CANCELLED-25431 ALESSANDRO	\$259.52
	246196	08/30/2023	BOW22-0289	REFUND PERMIT FEES-PERMIT CANCELLED-25287 ALESSANDRO	\$177.92
Remit to: LAKESIDE, CA					FYTD: \$1,712.32

Attachment: August2023PaymentRegisterSR (6410 : AUGUST PAYMENT REGISTER 2023)



City of Moreno Valley
Payment Register
For Period 8/1/2023 through 8/31/2023

CHECKS UNDER \$25,000

<u>Vendor Name</u>	<u>Check/EFT Number</u>	<u>Payment Date</u>	<u>Inv Number</u>	<u>Invoice Description</u>	<u>Payment Amount</u>
PERMITROCKET SOFTWARE LLC DBA EPERMITHUB	38167	08/23/2023	2308	EPERMITHUB DIGITAL PLAN ROOM CUSTOMER SUCCESS-TECH SERV	\$8,557.50
Remit to: MIAMI, FL					<u>FYTD:</u> \$8,557.50
PETTY CASH - FINANCE	245952	08/02/2023	JUL2022-JUN2023	PETTY CASH FUND REPLENISHMENT	\$2,673.58
Remit to: MORENO VALLEY, CA					<u>FYTD:</u> \$2,673.58
PIGGUE, LINDA	246134	08/23/2023	2003540.047	DEPOSIT REFUND-TOWNGATE COMM. CTR	\$230.50
Remit to: MORENO VALLEY, CA					<u>FYTD:</u> \$230.50
PINS & NEEDLES	246014	08/16/2023	14700	POLOS & HATS FOR CODE & PARKING CONTROL STAFF	\$470.87
	246158	08/30/2023	14716	EMBROIDERY FOR VELCRO PATCHES FOR TACTICAL VESTS-CODE/PK RANGERS	\$420.23
Remit to: HEMET, CA					<u>FYTD:</u> \$891.10
PRIME ACTUARIAL CONSULTING LLC	38230	08/30/2023	30062	WORKERS' COMP / LIABILITY PROGRAMS ACTUARIAL REVIEW-RISK MGT/HR	\$7,000.00
Remit to: SACRAMENTO, CA					<u>FYTD:</u> \$7,000.00
PRIORIT CONSULTING, LLC	38168	08/23/2023	PC 378	GIS SERVER SUPPORT SERVICES	\$2,100.00
Remit to: REDLANDS, CA					<u>FYTD:</u> \$2,100.00
PROFESSIONAL COMMUNICATIONS NETWORK PCN	246015	08/16/2023	222100403	LIVE ANSWERING SERVICE FOR ROTATIONAL TOW PROGRAM	\$407.23
Remit to: RIVERSIDE, CA					<u>FYTD:</u> \$407.23

Attachment: August2023PaymentRegisterSR (6410 : AUGUST PAYMENT REGISTER 2023)



City of Moreno Valley
Payment Register
For Period 8/1/2023 through 8/31/2023

CHECKS UNDER \$25,000

Vendor Name	Check/EFT Number	Payment Date	Inv Number	Invoice Description	Payment Amount
PROFESSIONAL DEVELOPMENT ACADEMY, LLC	38231	08/30/2023	118688	HIGH PERFORMANCE LEADERSHIP TRAINING - ALVAREZ	\$1,895.00
Remit to: CLACKAMAS, OR					FYTD: \$1,895.00
PTS COMMUNICATIONS INC	38169	08/23/2023	2107296	PAY PHONE SERVICES-JUL. 2023	\$282.22
		08/23/2023	2108684	PAY PHONE SERVICES-AUG. 2023	
Remit to: SAN RAMON, CA					FYTD: \$282.22
PVP COMMUNICATIONS, INC.	38120	08/16/2023	133277	REPAIR OF MOTOR HELMET RADIO GEAR	\$227.26
Remit to: TORRANCE, CA					FYTD: \$227.26
QUADIENT LEASING USA, INC.	38170	08/23/2023	N10046386	MAIL MACHINE LEASE FEES	\$2,387.10
		08/23/2023	N9917836	MAIL MACHINE LEASE FEES 5/27/23-8/26/23	
Remit to: DALLAS, TX					FYTD: \$2,387.10
QUALITY CODE PUBLISHING	245940	08/02/2023	GC0010771	SUPPLEMENT SERVICE TO THE MV MUNICIPAL CODE	\$3,413.90
		08/02/2023	GC0011062	SUPPLEMENT SERVICE TO THE MV MUNICIPAL CODE	
Remit to: DETROIT, MI					FYTD: \$3,413.90
RACHEL LANDREY DBA STREETBEAT AVE	38232	08/30/2023	AUG. 22, 2023	MAYOR'S DONATION FOR CHRISTMAS TOY DRIVE @ MV MALL SPONSORSHIP	\$300.00
Remit to: MORENO VALLEY, CA					FYTD: \$300.00
RAMOS, OSCAR	246081	08/16/2023	BFC23-0113	REFUND PLAN REVIEW FEES - NO TENANT IMPROVEMENT 13373 PERRIS	\$1,690.00
Remit to: MORENO VALLEY, CA					FYTD: \$1,690.00

Attachment: August2023PaymentRegisterSR (6410 : AUGUST PAYMENT REGISTER 2023)



City of Moreno Valley
Payment Register
For Period 8/1/2023 through 8/31/2023

CHECKS UNDER \$25,000

<u>Vendor Name</u>	<u>Check/EFT Number</u>	<u>Payment Date</u>	<u>Inv Number</u>	<u>Invoice Description</u>	<u>Payment Amount</u>
RAMOS, ROBERTO	38233	08/30/2023	JUL. 2023	INSTRUCTOR SERVICES-AMAZING MARTIAL ARTS & TAE KWON DO CLASSES	\$1,487.50
Remit to: MORENO VALLEY, CA					FYTD: \$2,994.60
RD SYSTEMS, INC.	38171	08/23/2023	101546	SW ENTRY DOOR KEY PIN PAD REPAIR-PUBLIC SAFETY BLDG.	\$420.00
	38234	08/30/2023	101554	EAST DOOR KEY CARD READER REPAIR-CITY YARD SANTIAGO	\$589.62
Remit to: TUSTIN, CA					FYTD: \$1,009.62

Attachment: August2023PaymentRegisterSR (6410 : AUGUST PAYMENT REGISTER 2023)



City of Moreno Valley
Payment Register
For Period 8/1/2023 through 8/31/2023

CHECKS UNDER \$25,000

<u>Vendor Name</u>	<u>Check/EFT Number</u>	<u>Payment Date</u>	<u>Inv Number</u>	<u>Invoice Description</u>	<u>Payment Amount</u>
READY REFRESH BY NESTLE	38001	08/02/2023	03F6703657388	WATER DISPENSER UNIT RENTAL-FIRE STATION 58	\$864.77
		08/02/2023	03F6703657389	WATER DISPENSER UNIT RENTAL-FIRE STATION 99	
		08/02/2023	03F6703657393	WATER DISPENSER UNIT RENTAL-ANIMAL SHELTER	
		08/02/2023	03F6703657396	WATER DISPENSER UNIT RENTAL-ANIMAL SHELTER	
		08/02/2023	03F6703657399	WATER DISPENSER UNIT RENTAL-FIRE STATION 6	
		08/02/2023	03F6703657401	WATER DISPENSER UNIT RENTAL-SENIOR CENTER	
		08/02/2023	03F6703657403	WATER DISPENSER UNIT RENTAL-FIRE STATION 48	
		08/02/2023	03F6703657407	WATER DISPENSER UNIT RENTAL-CRC	
		08/02/2023	03F6703657409	WATER DISPENSER UNIT RENTAL-ANNEX 1	
		08/02/2023	03F6703657410	WATER DISPENSER UNIT RENTAL-ANNEX 1	
		08/02/2023	03F6703657413	WATER DISPENSER UNITS RENTAL-BERC	
		08/02/2023	03F6703658235	WATER DISPENSER UNIT RENTAL-PSB HALLWAY KITCHEN	
		08/02/2023	03F6703658237	WATER DISPENSER UNIT RENTAL-PUBLIC SAFETY BUILDING	
		08/02/2023	03F6703658271	WATER DISPENSER UNIT RENTAL-CITY YARD SANTIAGO OFFICE	
		08/02/2023	03F6703658273	WATER DISPENSER UNIT RENTAL-FIRE STATION 91	
		08/02/2023	03F6703658274	WATER DISPENSER UNIT RENTAL-MAIN LIBRARY	
		08/02/2023	03F6703660049	WATER DISPENSER UNIT RENTAL-CITY HALL PW AREA	
		08/02/2023	03F6703660050	WATER DISPENSER UNIT RENTAL-CITY HALL DEV SVCS AREA	
		08/02/2023	03F6703660052	WATER DISPENSER UNIT RENTAL-CITY HALL LOBBY	
		08/02/2023	03F6703660053	WATER DISPENSER UNIT RENTAL-CITY HALL CITY CLERK AREA	
		08/02/2023	03F6703660054	WATER DISPENSER UNIT RENTAL-CITY HALL COUNCIL CHAMBER	
		08/02/2023	03F6703660056	WATER DISPENSER UNIT RENTAL-CITY HALL BREAKROOM	
		08/02/2023	03F6703660057	WATER DISPENSER UNIT RENTAL-CITY YARD	
		08/02/2023	03F6703660060	WATER DISPENSER UNIT RENTAL-RAINBOW RIDGE	
		08/02/2023	03F6703686057	WATER DISPENSER UNIT RENTAL-EOC	
		08/02/2023	03F6703686058	WATER DISPENSER UNIT RENTAL-VAL VERDE (RED MAPLE) SITE	
		08/02/2023	03F6705245066	WATER DISPENSER UNIT RENTAL-PUBLIC SAFETY BUILDING	
		08/02/2023	03F6706250063	WATER DISPENSER UNIT RENTAL-FIRE STATION 65	
		08/02/2023	03F6706250064	WATER DISPENSER UNIT RENTAL-FIRE STATION 2	

Attachment: August2023PaymentRegisterSR (6410 : AUGUST PAYMENT REGISTER 2023)



City of Moreno Valley
Payment Register
 For Period 8/1/2023 through 8/31/2023

CHECKS UNDER \$25,000

<u>Vendor Name</u>	<u>Check/EFT Number</u>	<u>Payment Date</u>	<u>Inv Number</u>	<u>Invoice Description</u>	<u>Payment Amount</u>
READY REFRESH BY NESTLE	38001	08/02/2023	03G0035449180	BOTTLED WATER COOLER RENTAL-ARMADA ELEMENTARY/CHILD CARE	\$864.77
		08/02/2023	03G0035449305	BOTTLED WATER COOLER RENTAL-CREEKSIDE ELEMENTARY/CHILD CARE	
	38235	08/30/2023	03H0035449180	BOTTLED WATER & DELIVERY FEE-ARMADA ELEMENTARY/CHILD CARE	\$41.82
		08/30/2023	03H0035449305	BOTTLED WATER & DELIVERY FEE-CREEKSIDE ELEMENTARY/CHILD CARE	
Remit to: LOUISVILLE, KY					<u>FYTD:</u> \$964.03
REGALADO, BLANCA E	38172	08/23/2023	JULY 2023	INSTRUCTOR SERVICES-FOLKLORIC DANCE ADULT & YOUTH CLASSES	\$744.00
Remit to: LAKE ELSINORE, CA					<u>FYTD:</u> \$1,459.20
RESTORATION JUBILEE CENTER	246082	08/16/2023	2003534.047	ACCOUNT CREDIT REFUND	\$200.00
Remit to: MORENO VALLEY, CA					<u>FYTD:</u> \$200.00
RHYTHM TECH PRODUCTIONS, LLC	38070	08/09/2023	1102	AUDIO/VISUAL EQUIPMENT & SERVICES FOR JULY 4TH EVENT	\$13,406.25
	38121	08/16/2023	1116	AUDIO/VISUAL & LIGHTING SVCS-MOVAL 2023 SUMMER CONCERTS & MOVIES	\$6,361.00
	38173	08/23/2023	1094	SOUND ENGINEER SERVICES FOR RENTAL-MOVAL BACK TO SCHOOL FEST	\$672.00
Remit to: COLTON, CA					<u>FYTD:</u> \$22,622.25
RINCON CONSULTANTS, INC.	38122	08/16/2023	49468	HOMEKEY PROJECT PHASE 1 SERVICES	\$4,107.90
Remit to: VENTURA, CA					<u>FYTD:</u> \$4,107.90
RIVERA, RALPH	246083	08/16/2023	2003517.047	ACCOUNT CREDIT REFUND	\$250.00
Remit to: PERRIS, CA					<u>FYTD:</u> \$250.00

Attachment: August2023PaymentRegisterSR (6410 : AUGUST PAYMENT REGISTER 2023)



City of Moreno Valley
Payment Register
 For Period 8/1/2023 through 8/31/2023

CHECKS UNDER \$25,000

<u>Vendor Name</u>	<u>Check/EFT Number</u>	<u>Payment Date</u>	<u>Inv Number</u>	<u>Invoice Description</u>	<u>Payment Amount</u>
RIVERSIDE AREA RAPE CRISIS CENTER	38002	08/02/2023	APR2023-10	CDBG FY22/23 SUBGRANTEE PAYMENT-SAFE COMMUNITIES PROJECT	\$1,632.64
		08/02/2023	JAN2023-07.1	CDBG FY22/23 SUBGRANTEE PAYMENT-SAFE COMMUNITIES PROJECT	
		08/02/2023	MAY2023-11	CDBG FY22/23 SUBGRANTEE PAYMENT-SAFE COMMUNITIES PROJECT	
	38090	08/15/2023	APR2023-10.1	CDBG FY22/23 SUBGRANTEE PAYMENT-SAFE COMMUNITIES PROJECT	\$4,116.82
		08/15/2023	JUN2023-12	CDBG FY22/23 SUBGRANTEE PAYMENT-SAFE COMMUNITIES PROJECT	
Remit to: RIVERSIDE, CA					FYTD: \$5,968.77
RIVERSIDE COUNTY OFFICE OF EDUCATION	245979	08/09/2023	2023/2731	TRANSLATION SERVICES-CITY COUNCIL MTGS/STUDY SESSION 6/6-6/13/23	\$482.19
		08/09/2023	2023/2731 (TSC)	TRANSLATION SERVICES-TRAFFIC SAFETY COMMISSION MEETING 6/7/23	
Remit to: RIVERSIDE, CA					FYTD: \$1,083.44
RIVERSIDE COUNTY SHERIFF-PSEC UNIT	246017	08/16/2023	PE0000001142	PSEC RADIO SUBSCRIPTIONS-CODE 7/1-7/31/23	\$1,286.18
		08/16/2023	PE0000001143	PSEC RADIO SUBSCRIPTIONS-PARK RANGERS 7/1-7/31/23	
		08/16/2023	PE0000001144	PSEC RADIO SUBSCRIPTIONS-OEM 7/1-7/31/23	
Remit to: RIVERSIDE, CA					FYTD: \$2,276.68
RIVERSIDE MEDICAL CLINIC	38071	08/09/2023	700000183-3/8/23	PRE-EMPLOYMENT PHYSICALS & DRUG SCREENINGS	\$1,993.00
	38236	08/30/2023	700000183-4/7/23	PRE-EMPLOYMENT PHYSICALS & DRUG SCREENINGS	\$8,564.00
		08/30/2023	700000183-6/7/23	PRE-EMPLOYMENT PHYSICALS & DRUG SCREENINGS	
		08/30/2023	700000183-7/7/23	PRE-EMPLOYMENT PHYSICALS & DRUG SCREENINGS	
Remit to: RIVERSIDE, CA					FYTD: \$10,557.00

Attachment: August2023PaymentRegisterSR (6410 : AUGUST PAYMENT REGISTER 2023)



**City of Moreno Valley
Payment Register
For Period 8/1/2023 through 8/31/2023**

CHECKS UNDER \$25,000

<u>Vendor Name</u>	<u>Check/EFT Number</u>	<u>Payment Date</u>	<u>Inv Number</u>	<u>Invoice Description</u>	<u>Payment Amount</u>
RIVERSIDE UNIVERSITY HEALTH SYSTEMS - MEDICAL CTR	38174	08/23/2023	2023-06 RSO MV	SART EXAMS - JUNE 2023	\$12,400.00
		08/23/2023	2023-07 RSO MV	SART EXAMS - JULY 2023	
Remit to: MORENO VALLEY, CA					FYTD: \$12,400.00
RMA GROUP, INC	245980	08/09/2023	85784	801 0086 JUAN BAUTISTA TRAIL ATP 4	\$6,645.00
		08/09/2023	85786	801 0086 JUAN BAUTISTA TRAIL ATP 4	
Remit to: RANCHO CUCAMONGA, CA					FYTD: \$8,775.00
ROADPOST USA INC DBA BLUECOSMO	38124	08/16/2023	BU01587398	SATELLITE PHONE SERVICE PLAN-FIRE	\$1,339.00
	38237	08/30/2023	BU01597854	SATELLITE PHONE SERVICE PLAN-FIRE	\$1,339.00
Remit to: SEATTLE, WA					FYTD: \$2,678.00
ROMAN TINT, INC	38072	08/09/2023	3124	6 ROLLER SHADE & 5% WINDOW TINT IN GYM-FIRE STATION 48	\$1,969.79
Remit to: RIALTO, CA					FYTD: \$1,969.79
ROMO PLANNING GROUP INC	38125	08/16/2023	2023-06	PLANNING CONSULTANT SERVICES - 6/04-6/30/23	\$18,317.50
Remit to: RANCHO CUCAMONGA, CA					FYTD: \$27,252.50
ROMO, ANALILIA	246084	08/16/2023	MVA010032619	REFUND PARKING CITATION FEE - VIOLATION DISMISSED	\$57.50
Remit to: MODESTO, CA					FYTD: \$57.50
ROSA, SHAWNDEL	246135	08/23/2023	13767	ONE-TIME PAYMENT CORRECTION OF TOW FEES CHARGED	\$281.00
Remit to: MORENO VALLEY, CA					FYTD: \$281.00
ROYAL FLUSH CASINO EVENTS	246164	08/30/2023	A0791	SERVICES FOR CASINO EVENT AT SENIOR CENTER ON 8/31/23	\$2,320.00
Remit to: WESTMINSTER, CA					FYTD: \$2,320.00

Attachment: August2023PaymentRegisterSR (6410 : AUGUST PAYMENT REGISTER 2023)



City of Moreno Valley
Payment Register
For Period 8/1/2023 through 8/31/2023

CHECKS UNDER \$25,000

Vendor Name	Check/EFT Number	Payment Date	Inv Number	Invoice Description	Payment Amount
RUELAS, JAIME	246136	08/23/2023	BFR20-0115.R002	REFUND PLAN CHECK FEES-VOIDED SUBMITTAL-11690 MATHEWS RD	\$474.00
Remit to: MORENO VALLEY, CA					FYTD: \$474.00
SAFEWAY SIGN CO.	38175	08/23/2023	55246	TRAFFIC SIGNS/HARDWARE	\$312.00
Remit to: ADELANTO, CA					FYTD: \$2,200.87
SANCHEZ, GUADALUPE	246085	08/16/2023	MVA020062779	REFUND PARKING CITATION FEE - VIOLATION DISMISSED	\$57.50
Remit to: MORENO VALLEY, CA					FYTD: \$57.50
SEARLE CREATIVE GROUP, LLC	38126	08/16/2023	23406	PROACTIVE WEBSITE MAINTENANCE PLAN FOR MORENOVALLEYBUSINESS.COM	\$10,000.00
Remit to: VENTURA, CA					FYTD: \$12,921.25
SECURITY SIGNAL DEVICES, INC. DBA SSD ALARM	38074	08/09/2023	R-00453302	ALARM SYSTEM SERVICES FOR MOVAL & KITCHING SUBSTATIONS- JUL. 2023	\$1,030.94
		08/09/2023	R-00462782	ALARM SYSTEM SERVICES FOR MOVAL & KITCHING SUBSTATIONS- AUG. 2023	
	38238	08/30/2023	R-00468991	ALARM SYSTEM SERVICES FOR MOVAL & KITCHING SUBSTATIONS- SEP. 2023	\$515.47
Remit to: ANAHEIM, CA					FYTD: \$1,546.41
SERNA, STACY	246086	08/16/2023	2003518.047	ACCOUNT CREDIT REFUND	\$77.30
Remit to: MORENO VALLEY, CA					FYTD: \$77.30
SKY PUBLISHING	38239	08/30/2023	23_5_464	FULL PAGE MAGAZINE AD-FLOOD PLAIN MGMT PUBLIC SVC MSG/2023 ISS 5	\$1,500.00
Remit to: MORENO VALLEY, CA					FYTD: \$1,500.00

Attachment: August2023PaymentRegisterSR (6410 : AUGUST PAYMENT REGISTER 2023)



City of Moreno Valley
Payment Register
For Period 8/1/2023 through 8/31/2023

CHECKS UNDER \$25,000

Vendor Name	Check/EFT Number	Payment Date	Inv Number	Invoice Description	Payment Amount
SOLCIUS LLC	246137	08/23/2023	BON22-1245	REFUND PERMIT FEES-PROJECT CANCELLED-25922 CALLE ENSENADA	\$263.04
Remit to: PROVO, UT					FYTD: \$263.04
SOUTH COAST AIR QUALITY MANAGEMENT DISTRICT	246106	08/23/2023	4217518	ANNUAL RENEWAL FEES INVOICE-FIRE STATION 65	\$974.86
		08/23/2023	4218032	ANNUAL RENEWAL FEES INVOICE-FIRE STATION 99	
		08/23/2023	4219254	EMISSIONS FEES INVOICE-FIRE STATION 65	
		08/23/2023	4221722	EMISSIONS FEES INVOICE-FIRE STATION 99	
Remit to: DIAMOND BAR, CA					FYTD: \$974.86
SOUTHERN CALIFORNIA EDISON	245941	08/02/2023	JUL-23 8/2/23	ELECTRICITY CHARGES	\$8,479.34
	245981	08/09/2023	JUL-23 8/9/23	ELECTRICITY CHARGES	\$15,055.68
		08/09/2023	JUN-23 8/9/23	ELECTRICITY CHARGES	
	246159	08/30/2023	AUG-23 8/30/23	ELECTRICITY CHARGES	\$12,715.66
		08/30/2023	JUL-23 8/30/23	ELECTRICITY CHARGES	
	246160	08/30/2023	515478	DOC# 7590506899-NEW METER & SVC/REQ#3539992/11790 PIGEON PASS RD	\$1,664.26
Remit to: ROSEMEAD, CA					FYTD: \$400,617.68
SOUTHERN CALIFORNIA GAS CO.	246161	08/30/2023	JULY-2023	GAS CHARGES	\$3,487.73
Remit to: MONTEREY PARK, CA					FYTD: \$8,109.65
SOUTHWEST OFFSET PRINTING CO., INC.	246018	08/16/2023	204286	PRINTING, ETC. FOR SOARING ACTIVITY GUIDES/SEP-DEC 2023 ISSUE	\$20,428.90
Remit to: GARDENA, CA					FYTD: \$20,428.90
SOUTHWEST POWER POOL, INC.	38004	08/02/2023	WIUFMP452PY28	PLAN YEAR 28 BILLING - MV UTILITY	\$534.01
Remit to: LITTLE ROCK, AR					FYTD: \$534.01

Attachment: August2023PaymentRegisterSR (6410 : AUGUST PAYMENT REGISTER 2023)



City of Moreno Valley
Payment Register
For Period 8/1/2023 through 8/31/2023

CHECKS UNDER \$25,000

Vendor Name	Check/EFT Number	Payment Date	Inv Number	Invoice Description	Payment Amount
SPARKLETTS	38005	08/02/2023	6435574 070723	BOTTLED WATER SERVICE FOR CITY YARD	\$249.98
	38177	08/23/2023	6435574 080423	BOTTLED WATER SERVICE FOR CITY YARD	\$296.83
Remit to: DALLAS, TX					FYTD: \$546.81
STATE BOARD OF EQUALIZATION 1	38285	08/25/2023	073123	SALES & USE TAX REPORT FOR 7/1-7/31/23	\$884.00
Remit to: SACRAMENTO, CA					FYTD: \$6,790.00
STATE OF CALIFORNIA DEPT. OF JUSTICE	245943	08/02/2023	665053	BLOOD ALCOHOL ANALYSIS SERVICES FOR PD-JUN. 2023	\$840.00
	245944	08/02/2023	665886	LIVE SCAN FINGERPRINTING APPS FOR PD-JUN. 2023	\$1,415.00
	246019	08/16/2023	646575	LIVE SCAN FINGERPRINTING SERVICES - MAR. 2023	\$6,540.00
		08/16/2023	652962	LIVE SCAN FINGERPRINTING SERVICES - APR. 2023	
		08/16/2023	659331	LIVE SCAN FINGERPRINTING SERVICES - MAY 2023	
		08/16/2023	666059	LIVE SCAN FINGERPRINTING SERVICES - JUN. 2023	
246108	08/23/2023	672218	LIVE SCAN FINGERPRINTING APPS FOR PD-JUL. 2023	\$964.00	
Remit to: SACRAMENTO, CA					FYTD: \$9,759.00
STATE WATER RESOURCES CONTROL BOARD 1	245982	08/09/2023	SW-0259009	801 0077 JB TRAIL ATP3 ANNUAL PERMIT FEE	\$704.00
Remit to: SACRAMENTO, CA					FYTD: \$704.00
STATEWIDE TRAFFIC SAFETY AND SIGNS, INC	38076	08/09/2023	13011049	TRAFFIC SAFETY EQUIPMENT-ORANGE T-SHIRTS & LIME VESTS	\$958.97
	38127	08/16/2023	13010989	QUOTE# 13006327-JULY 4TH TRAFFIC EQUIPMENT RENTAL (QUOTED RATE)	\$2,504.25
Remit to: PASADENA, CA					FYTD: \$3,463.22

Attachment: August2023PaymentRegisterSR (6410 : AUGUST PAYMENT REGISTER 2023)



City of Moreno Valley
Payment Register
For Period 8/1/2023 through 8/31/2023

CHECKS UNDER \$25,000

Vendor Name	Check/EFT Number	Payment Date	Inv Number	Invoice Description	Payment Amount
STEVEN B. QUINTANILLA A PROFESSIONAL CORPORATION	38240	08/30/2023	JUL-23/MILLER	SPECIAL COUNSEL LITIGATION SVCS-MILLER STARR REG. 07/01-07/31/23	\$840.00
Remit to: PALM SPRINGS, CA					FYTD: \$314,991.65
STEVEN PERRY PROFESSIONAL PHOTOGRAPHY	38178	08/23/2023	230804.1	PHOTOGRAPHY SERVICES 7/20-8/3/23 - STATE OF THE CITY PRE-EVENT	\$2,141.25
		08/23/2023	230804.2	PHOTOGRAPHY SERVICES 8/1/23 - NATIONAL NIGHT OUT	
		08/23/2023	230815.1	PHOTOGRAPHY SERVICES 8/12/23 - COMMUNITY DAY OF SERVICE EVENT	
		08/23/2023	230815.2	PHOTOGRAPHY SERVICES 8/15/23 - MOVAL SELFIE DAY EVENT	
	38241	08/30/2023	230819.1	PHOTOGRAPHY SERVICES 8/17/23 - STATE OF THE CITY EVENT	\$903.75
Remit to: MORENO VALLEY, CA					FYTD: \$5,357.50
STEWART TITLE OF CALIFORNIA, INC.	246024	08/16/2023	698347	TITLE REPORT - FILE #2084922 S. HIDEY 12914 ROBERTS WAY	\$788.00
Remit to: RIVERSIDE, CA					FYTD: \$788.00
STILES ANIMAL REMOVAL, INC.	245983	08/09/2023	3522	DECEASED LARGE ANIMAL REMOVAL SERVICES-JUL. 2023	\$3,245.00
Remit to: GUAISTI, CA					FYTD: \$5,715.00
STRADLING, YOCCA, CARLSON & RAUTH	38007	08/02/2023	398796-0008	LEGAL SERVICES-FORECLOSURE 12914 ROBERTS WAY MATTER-JUN. 2023	\$12,447.00
		08/02/2023	398797-0009	LEGAL SERVICES-24124/24108 FIR AVE SURPLUS LAND MATTER-JUN, 2023	
Remit to: NEWPORT BEACH, CA					FYTD: \$26,500.50

Attachment: August2023PaymentRegisterSR (6410 : AUGUST PAYMENT REGISTER 2023)



**City of Moreno Valley
Payment Register
For Period 8/1/2023 through 8/31/2023**

CHECKS UNDER \$25,000

<u>Vendor Name</u>	<u>Check/EFT Number</u>	<u>Payment Date</u>	<u>Inv Number</u>	<u>Invoice Description</u>	<u>Payment Amount</u>
SUNNYMEAD ACE HARDWARE	245945	08/02/2023	98984	MISC. SUPPLIES FOR FIRE STATION 91	\$163.90
		08/02/2023	98985	MISC. SUPPLIES FOR FIRE STATION 48	
		08/02/2023	99117	MISC. SUPPLIES FOR FIRE STATION 2	
	245984	08/09/2023	98655	MISC. SUPPLIES FOR PD - LOBBY	\$139.74
		08/09/2023	99028	MISC. SUPPLIES FOR PD - SUB-STATION KEYS	
		08/09/2023	99041	MISC. SUPPLIES FOR PD	
		08/09/2023	99047	MISC. SUPPLIES FOR PD - KEYS	
	246020	08/09/2023	99214	MISC. SUPPLIES FOR PD - TRAFFIC KEYS	
		08/16/2023	99254	MISC. SUPPLIES FOR FIRE STATION 2	\$26.46
	246109	08/23/2023	99227	MISC. SUPPLIES FOR PD	\$89.25
99275			CREDIT FOR ITEMS RETURNED		
08/23/2023		99331	MISC. SUPPLIES FOR PD		
		99348	MISC. SUPPLIES FOR PD		
Remit to: MORENO VALLEY, CA					FYTD: \$637.57
SUPERIOR READY MIX CONCRETE	246021	08/16/2023	358040	DELIVERY OF MIXED CONCRETE	\$3,773.50
		08/16/2023	359647	DELIVERY OF MIXED CONCRETE	
Remit to: ESCONDIDO, CA					FYTD: \$16,379.38
SVA ARCHITECTS, INC.	38077	08/09/2023	60895R	803 0057_SENIOR CENTER EXPANSION	\$6,162.50
Remit to: SANTA ANA, CA					FYTD: \$6,162.50
TEJEDA, MICHELLE	246138	08/23/2023	2003541.047	DEPOSIT REFUND-COTTONWOOD GOLF CTR	\$209.60
Remit to: MORENO VALLEY, CA					FYTD: \$209.60
THE ADVANTAGE GROUP/ FLEX ADVANTAGE	38179	08/23/2023	160180	FLEX AND COBRA ADMIN FEES-JUL. 2023	\$1,573.15
Remit to: TEMECULA, CA					FYTD: \$100,848.72

Attachment: August2023PaymentRegisterSR (6410 : AUGUST PAYMENT REGISTER 2023)



**City of Moreno Valley
Payment Register
For Period 8/1/2023 through 8/31/2023**

CHECKS UNDER \$25,000

<u>Vendor Name</u>	<u>Check/EFT Number</u>	<u>Payment Date</u>	<u>Inv Number</u>	<u>Invoice Description</u>	<u>Payment Amount</u>
THERMAL-COOL INC.	38129	08/16/2023	65900	MAINTENANCE FOR SUNNYMEAD PARK SNACK BAR ICE MACHINE	\$230.00
		08/16/2023	65901	MAINTENANCE FOR LASSELLE SPORTS PARK SNACK BAR	
Remit to: RIVERSIDE, CA					FYTD: \$230.00
THOMPSON COBURN LLP	38010	08/02/2023	3616754	LEGAL SERVICES-MVU/RELIABILITY STANDARD COMPLIANCE/JUN. 2023	\$35.27
		38243	08/30/2023	3621183	LEGAL SERVICES-MVU/RELIABILITY STANDARD COMPLIANCE/JUL. 2023
Remit to: WASHINGTON, DC					FYTD: \$133.23
T-MOBILE USA, INC.	245946	08/02/2023	9539652941	CELLULAR TECHNOLOGY EXTRACTION/LOCATOR SERVICES FOR PD	\$25.00
		08/09/2023	9539652943	CELLULAR TECHNOLOGY EXTRACTION/LOCATOR SERVICES FOR PD	\$350.00
		08/09/2023	9539652944	CELLULAR TECHNOLOGY EXTRACTION/LOCATOR SERVICES FOR PD	
		08/09/2023	9539652945	CELLULAR TECHNOLOGY EXTRACTION/LOCATOR SERVICES FOR PD	
		08/09/2023	9540345855	CELLULAR TECHNOLOGY EXTRACTION/LOCATOR SERVICES FOR PD	
Remit to: SEATTLE, WA					FYTD: \$375.00
TORTORO ENTERPRISES INC. DBA FUN SERVICES	246110	08/23/2023	232093	PRIZES & RENTALS-4TH OF JULY	\$7,340.00
Remit to: YORBA LINDA, CA					FYTD: \$7,340.00
TOUCH OF SOUL	38181	08/23/2023	JULY 2023	INSTRUCTOR SERVICES - SOUL LINE DANCING CLASS	\$516.00
Remit to: MORENO VALLEY, CA					FYTD: \$1,006.20
TRANSTECH ENGINEERS, INC.	245948	08/02/2023	20231764	TRANSPORTATION PLANNING SVCS-PROJ 230064 MV TRF BELAGO PARK TIA	\$15,268.75
		08/02/2023	20233356	801 0064 SR60/REDLANDS BLVD INTERCHANGE	
Remit to: CHINO, CA					FYTD: \$38,435.17

Attachment: August2023PaymentRegisterSR (6410 : AUGUST PAYMENT REGISTER 2023)



**City of Moreno Valley
Payment Register
For Period 8/1/2023 through 8/31/2023**

CHECKS UNDER \$25,000

<u>Vendor Name</u>	<u>Check/EFT Number</u>	<u>Payment Date</u>	<u>Inv Number</u>	<u>Invoice Description</u>	<u>Payment Amount</u>
TRESTLES ENVIRONMENTAL CORPORATION	246022	08/16/2023	30-23	BURROWING OWL SURVEY & FINDINGS MEMO FOR POORMAN'S RESERVOIR	\$1,600.00
Remit to: FALLBROOK, CA					FYTD: \$1,600.00
TRICHE, TARA	38182	08/23/2023	JULY 2023	INSTRUCTOR SERVICES - BALLET & DANCE EXPLORATION CLASSES	\$1,436.40
Remit to: MORENO VALLEY, CA					FYTD: \$2,973.60
TRINITY DIVERSIFIED, INC.	245949	08/02/2023	8623	PARTS/SUPPLIES FOR STRIPING & STENCIL TRUCKS	\$169.21
Remit to: GARDENA, CA					FYTD: \$169.21
TRU PWR CA LLC	246139	08/23/2023	BON23-1170	REFUND PERMIT FEES-PROJECT CANCELLED-24745 QUENADA DR	\$263.04
Remit to: MENIFEE, CA					FYTD: \$263.04
TSG ENTERPRISES, INC. DBA THE SOLIS GROUP	38011	08/02/2023	11031	801 0087 CITYWIDE PVT REHAB FY 20/21	\$4,494.00
		08/02/2023	11036	801 0086 JUAN BAUTISTA DE ANZA MULTI-USE TRAIL - ATP 4	
	38079	08/09/2023	11032	801 0096 CITYWIDE PVT REHAB PROG (FY 21-26)	\$5,485.00
		08/09/2023	11033	801 0089 CITYWIDE PVT REHAB FY 21/22	
	38244	08/30/2023	11207	801 0096 CITYWIDE PVT REHAB PROG (FY 21-26)	\$16,535.00
		08/30/2023	11208	801 0089 CITYWIDE PVT REHAB FY 21/22	
		08/30/2023	11209	801 0097 PVT REHAB CWA	
		08/30/2023	11210	801 0090 CITYWIDE PVT REHAB PGM (FY26-31)	
		08/30/2023	11211	801 0086 JUAN BAUTISTA DE ANZA MULTI-USE TRAIL - ATP 4	
		08/30/2023	11212	801 0021 SR60/MORENO BEACH PH 2	
Remit to: PASADENA, CA					FYTD: \$37,456.00
TUCKER, SABRINA	246087	08/16/2023	R23-174968	ANIMAL SERVICES REFUND S/N DEPOSIT	\$75.00
Remit to: MORENO VALLEY, CA					FYTD: \$75.00

Attachment: August2023PaymentRegisterSR (6410 : AUGUST PAYMENT REGISTER 2023)



**City of Moreno Valley
Payment Register
For Period 8/1/2023 through 8/31/2023**

CHECKS UNDER \$25,000

<u>Vendor Name</u>	<u>Check/EFT Number</u>	<u>Payment Date</u>	<u>Inv Number</u>	<u>Invoice Description</u>	<u>Payment Amount</u>
TUMON BAY RESORT & SPA	38012	08/02/2023	AUG. 2023 RENT	AUG. 2023 RENT (INCL. CAM, ETC) FOR BUSINESS & EMP. RESOURCE CTR	\$8,488.45
	38245	08/30/2023	SEP. 2023 RENT	SEP. 2023 RENT (INCL. CAM, ETC) FOR BUSINESS & EMP. RESOURCE CTR	\$8,488.45
Remit to: TAMUNING, GU					<u>FYTD:</u> \$16,976.90
TYLER TECHNOLOGIES, INC.	246111	08/23/2023	025-423817	MYCIVICAPP SMARTPHONE APP SUBSCRIPTION 7/1/23 - 6/30/24	\$7,293.04
Remit to: DALLAS, TX					<u>FYTD:</u> \$8,507.28
U.S. BANK NA	38013	08/02/2023	13842698	INVESTMENT CUSTODIAL SERVICES-JUN. 2023	\$1,130.00
Remit to: ST. PAUL, MN					<u>FYTD:</u> \$2,095.00
ULTRASERV AUTOMATED SERVICES, LLC	38015	08/02/2023	263966	COFFEE SERVICE SUPPLIES-CITY HALL/PUBLIC WORKS LOCATION	\$465.09
		08/02/2023	263967	COFFEE SERVICE SUPPLIES-ANNEX 1	
		08/02/2023	263968	COFFEE SERVICE SUPPLIES-CONFERENCE & REC. CENTER	
	38130	08/16/2023	264045	COFFEE SERVICE SUPPLIES-CITY HALL/BREAK ROOM LOCATION	\$1,263.80
		08/16/2023	264046	COFFEE SERVICE SUPPLIES-ANNEX 1	
		08/16/2023	264058	COFFEE SERVICE SUPPLIES-ANIMAL SHELTER	
		08/16/2023	264184	COFFEE SERVICE SUPPLIES-CITY HALL/CITY CLERK LOCATION	
		08/16/2023	264252	COFFEE SERVICE SUPPLIES-CITY HALL/PUBLIC WORKS LOCATION	
		08/16/2023	264254	COFFEE SERVICE SUPPLIES-CITY HALL/BREAK ROOM LOCATION	
		08/16/2023	264340	COFFEE SERVICE SUPPLIES-ANNEX 1	
Remit to: COSTA MESA, CA					<u>FYTD:</u> \$3,407.06

Attachment: August2023PaymentRegisterSR (6410 : AUGUST PAYMENT REGISTER 2023)



City of Moreno Valley
Payment Register
For Period 8/1/2023 through 8/31/2023

CHECKS UNDER \$25,000

<u>Vendor Name</u>	<u>Check/EFT Number</u>	<u>Payment Date</u>	<u>Inv Number</u>	<u>Invoice Description</u>	<u>Payment Amount</u>
UNITED ROTARY BRUSH CORP	38080	08/09/2023	CI298385	STREET SWEEPER BRUSHES & ACCESSORIES	\$3,906.05
		08/09/2023	CI298581	STREET SWEEPER BRUSHES & ACCESSORIES	
		08/09/2023	CI298933	STREET SWEEPER BRUSHES & ACCESSORIES	
		08/09/2023	CI299242	STREET SWEEPER BRUSHES & ACCESSORIES	
		08/09/2023	CI299585	STREET SWEEPER BRUSHES & ACCESSORIES	
		08/09/2023	CI299932	STREET SWEEPER BRUSHES & ACCESSORIES	
	38183	08/23/2023	CI300169	STREET SWEEPER BRUSHES & ACCESSORIES	\$5,661.28
		08/23/2023	CI300745	STREET SWEEPER BRUSHES & ACCESSORIES	
		08/23/2023	CI300848	STREET SWEEPER BRUSHES & ACCESSORIES	
		08/23/2023	CI301057	STREET SWEEPER BRUSHES & ACCESSORIES	
		08/23/2023	CI301192	STREET SWEEPER BRUSHES & ACCESSORIES	
		08/23/2023	CI301193	STREET SWEEPER BRUSHES & ACCESSORIES	
		08/23/2023	CI301380	STREET SWEEPER BRUSHES & ACCESSORIES	
		08/23/2023	CI301695	STREET SWEEPER BRUSHES & ACCESSORIES	
Remit to: DALLAS, TX					<u>FYTD:</u> \$9,567.33
UNITED SITE SERVICES OF CA, INC.	38131	08/16/2023	114-13656756	FENCE RENTAL AT ANIMAL SHELTER 07/27-08/23/23	\$106.40
Remit to: DALLAS, TX					<u>FYTD:</u> \$212.80
USI, MARCH ED	246088	08/16/2023	2003519.047	ACCOUNT CREDIT REFUND	\$250.00
Remit to: MORENO VALLEY, CA					<u>FYTD:</u> \$250.00

Attachment: August2023PaymentRegisterSR (6410 : AUGUST PAYMENT REGISTER 2023)



City of Moreno Valley
Payment Register
For Period 8/1/2023 through 8/31/2023

CHECKS UNDER \$25,000

<u>Vendor Name</u>	<u>Check/EFT Number</u>	<u>Payment Date</u>	<u>Inv Number</u>	<u>Invoice Description</u>	<u>Payment Amount</u>
VACATE TERMITES & PEST ELIMINATION COMPANY	38184	08/23/2023	124344	PEST CONTROL SERVICE-JUL. 2023-FIRE STATION 6	\$2,685.00
		08/23/2023	124350	PEST CONTROL SERVICE-JUL. 2023-FIRE STATION 2	
		08/23/2023	124351	PEST CONTROL SERVICE-JUL. 2023-FIRE STATION 48	
		08/23/2023	124353	PEST CONTROL SERVICE-JUL. 2023-FIRE STATION 99	
		08/23/2023	124357	PEST CONTROL SERVICE-JUL. 2023-UTILITY FIELD OFFICE	
		08/23/2023	124358	PEST CONTROL SERVICE-JUL. 2023-FIRE STATION 58	
		08/23/2023	124359	PEST CONTROL SERVICE-JUL. 2023-FIRE STATION 65	
		08/23/2023	124360	PEST CONTROL SERVICE-JUL. 2023-FIRE STATION 91	
		08/23/2023	124381	PEST CONTROL SERVICE-JUL. 2023-MARCH ANNEX	
		08/23/2023	124383	PEST CONTROL SERVICE-JUL. 2023-MARCH FIELD PARK COMM. CENTER	
		08/23/2023	124388	PEST CONTROL SERVICE-JUL. 2023-TOWNGATE COMM. CENTER	
		08/23/2023	124389	MOSQUITO ABATEMENT TRAP/FLY LIGHT SERVICE-TOWNGATE COMM. CENTER	
		08/23/2023	124395	MOSQUITO ABATEMENT TRAP/FLY LIGHT SERVICE-SENIOR CENTER	
		08/23/2023	124396	PEST CONTROL SERVICE-JUL. 2023-SENIOR CENTER	
		08/23/2023	124545	BEE REMOVAL ON PATIO-TOWNGATE COMM CENTER	
		08/23/2023	124561	PEST SERVICE FOR ANTS-IRIS PLAZA LIBRARY	
		08/23/2023	124563	ANTS ALONG 2ND FLOOR WINDOW SEALS-CITY HALL	
		08/23/2023	124641	PEST CONTROL SERVICE-JUL. 2023-RAINBOW RIDGE	
		08/23/2023	124645	PEST CONTROL SERVICE-JUL. 2023-CITY HALL	
		08/23/2023	124646	PEST CONTROL SERVICE-JUL. 2023-CONFERENCE & REC. CENTER	
		08/23/2023	124647	PEST CONTROL SERVICE-JUL. 2023-EMERGENCY OPS CENTER	
		08/23/2023	124648	PEST CONTROL SERVICE-JUL. 2023-PUBLIC SAFETY BLDG.	
		08/23/2023	124649	MOSQUITO ABATEMENT TRAP/FLY LIGHT SERVICE-PUBLIC SAFETY BLDG.	
		08/23/2023	124652	PEST CONTROL SERVICE-JUL. 2023-ANIMAL SHELTER	

Attachment: August2023PaymentRegisterSR (6410 : AUGUST PAYMENT REGISTER 2023)



**City of Moreno Valley
Payment Register
For Period 8/1/2023 through 8/31/2023**

CHECKS UNDER \$25,000

<u>Vendor Name</u>	<u>Check/EFT Number</u>	<u>Payment Date</u>	<u>Inv Number</u>	<u>Invoice Description</u>	<u>Payment Amount</u>
VACATE TERMITES & PEST ELIMINATION COMPANY	38184	08/23/2023	124653	MOSQUITO ABATEMENT TRAP/FLY LIGHT SERVICE-ANIMAL SHELTER	\$2,685.00
		08/23/2023	124706	PEST CONTROL SERVICE-JUL. 2023-COTTONWOOD GOLF CENTER	
		08/23/2023	124707	PEST CONTROL SERVICE-JUL. 2023-MAIN LIBRARY	
		08/23/2023	124708	PEST CONTROL SERVICE-JUL. 2023-CITY YARD	
		08/23/2023	124709	PEST CONTROL SERVICE-JUL. 2023-TRANSPORTATION TRAILER	
		08/23/2023	124710	MOSQUITO ABATEMENT TRAP/FLY LIGHT SERVICE-CITY YARD	
		08/23/2023	124730	PEST TREATMENT FOR SPIDERS/ROACHES-CITY YARD	
		08/23/2023	124829	PEST TREATMENT FOR COCKROACHES-FIRE STATION 2	
	08/23/2023	124830	PEST TREATMENT FOR SPIDERS-CITY HALL		
Remit to: MORENO VALLEY, CA					FYTD: \$5,080.00
VALLEY WIDE TOWING, LLC	38081	08/09/2023	23-13388	EVIDENCE TOWING FOR PD	\$4,034.75
		08/09/2023	23-13425	EVIDENCE TOWING FOR PD	
		08/09/2023	23-13577	EVIDENCE TOWING FOR PD	
		08/09/2023	23-13578	EVIDENCE TOWING FOR PD	
		08/09/2023	23-13620	EVIDENCE TOWING FOR PD	
	38247	08/30/2023	23-13794	EVIDENCE TOWING FOR PD	\$843.00
		08/30/2023	23-13834	EVIDENCE TOWING FOR PD	
Remit to: MORENO VALLEY, CA					FYTD: \$4,877.75
VERIZON WIRELESS	245950	08/02/2023	9939305572	DATA CHARGES FOR CELLULAR SERVICE FOR PD DEVICES	\$415.15
	246162	08/30/2023	9941694965	DATA CHARGES FOR CELLULAR SERVICE FOR PD DEVICES	\$419.54
Remit to: DALLAS, TX					FYTD: \$834.69
VERTIGIS NORTH AMERICA DBA LATITUDE GEOGRAPHICS	246112	08/23/2023	IN-VGNA-00004942	GCX HOSTING/STANDARD SUBSCRIPTION 7/1/23-6/30/24 - CITY GIS SITE	\$10,770.00
Remit to: VICTORIA, BC					FYTD: \$12,680.00

Attachment: August2023PaymentRegisterSR (6410 : AUGUST PAYMENT REGISTER 2023)



**City of Moreno Valley
Payment Register
For Period 8/1/2023 through 8/31/2023**

CHECKS UNDER \$25,000

<u>Vendor Name</u>	<u>Check/EFT Number</u>	<u>Payment Date</u>	<u>Inv Number</u>	<u>Invoice Description</u>	<u>Payment Amount</u>
VICKERS, ALPHADAZA	246089	08/16/2023	2003530.047	ACCOUNT CREDIT REFUND	\$0.15
Remit to: MORENO VALLEY, CA					FYTD: \$0.15
VISION SERVICE PLAN	38082	08/09/2023	818191248	EMPLOYEE VISION INSURANCE	\$7,525.64
		08/09/2023	818405477	EMPLOYEE VISION INSURANCE	
Remit to: SAN FRANCISCO, CA					FYTD: \$11,233.88
VISTA PAINT CORPORATION	38016	08/02/2023	2023-086739-00	PAINTING SUPPLIES	\$161.47
		08/02/2023	2023-093285-00	PAINTING SUPPLIES	
Remit to: FULLERTON, CA					FYTD: \$42,510.32
VOSS, TYSON	246140	08/23/2023	REIMB. 8/21/23	REIMBURSE SNACKS/DRINKS COST FOR WEEK LONG PD CELLEBRITE CLASS	\$166.29
Remit to: MORENO VALLEY, CA					FYTD: \$166.29
VOYAGER FLEET SYSTEM, INC.	38084	08/09/2023	8693366022325	FUEL CARD CHARGES-PD TRAFFIC MOTORS	\$2,347.61
	38132	08/16/2023	8692116152325	CNG FUEL PURCHASES	\$8,056.95
	38185	08/23/2023	8692116152330	CNG FUEL PURCHASES	\$2,246.26
Remit to: HOUSTON, TX					FYTD: \$26,794.61
VULCAN MATERIALS CO, INC.	38017	08/02/2023	73644692	ASPHALTIC/CRACK SEAL MATERIALS	\$98.25
	38186	08/23/2023	73700064	ASPHALTIC EMULSION MATERIALS	\$685.08
		08/23/2023	73701994	ASPHALTIC EMULSION MATERIALS	
		08/23/2023	73711788	ASPHALTIC EMULSION MATERIALS	
		08/23/2023	73714694	ASPHALTIC EMULSION MATERIALS	
		08/23/2023	73714695	ASPHALTIC EMULSION MATERIALS	
		08/23/2023	73714696	ASPHALTIC EMULSION MATERIALS	
		08/23/2023	73717734	ASPHALTIC EMULSION MATERIALS	
Remit to: LOS ANGELES, CA					FYTD: \$5,217.45

Attachment: August2023PaymentRegisterSR (6410 : AUGUST PAYMENT REGISTER 2023)



**City of Moreno Valley
Payment Register
For Period 8/1/2023 through 8/31/2023**

CHECKS UNDER \$25,000

<u>Vendor Name</u>	<u>Check/EFT Number</u>	<u>Payment Date</u>	<u>Inv Number</u>	<u>Invoice Description</u>	<u>Payment Amount</u>
WALKER, MELISSA	246141	08/23/2023	8/26 - 8/30/23	TRAVEL PER DIEM - 2023 APWA PWX EXPO	\$333.00
Remit to: MORENO VALLEY, CA					FYTD: \$333.00
WAXIE ENTERPRISES, LLC DBA WAXIE SANITARY SUPPLY	38018	08/02/2023	81822794	JANITORIAL/CLEANING SUPPLIES FOR LIBRARY BRANCHES	\$617.18
	38085	08/09/2023	81847901	JANITORIAL SUPPLIES FOR PD	\$2,514.45
	38187	08/23/2023	81903084	JANITORIAL SUPPLIES FOR PD	\$788.73
Remit to: LOS ANGELES, CA					FYTD: \$4,244.19
WEBB MUNICIPAL FINANCE	245986	08/09/2023	20230079	SD ANNUAL ASSESSMENT ENGINEER'S REPORTS 23/24	\$7,577.02
Remit to: RIVERSIDE, CA					FYTD: \$7,577.02
WELLS FARGO CORPORATE TRUST	38137	08/10/2023	W230801	DEBT SERVICE-CFD NO 87-1 (TOWNGATE) IMP AREA 1 SPECIAL TAXES	\$1,853.61
Remit to: LOS ANGELES, CA					FYTD: \$743,518.92
WEST COAST ARBORISTS, INC.	38086	08/09/2023	196756	DIRECT PAY_801 0097 CITYWIDE PVMT REHAB PGM (FY26/27-30/31)	\$761.40
	38188	08/23/2023	200802	TREE TRIMMING SERVICES - CORPORATE YARD	\$1,954.70
Remit to: ANAHEIM, CA					FYTD: \$7,683.65
WEST COAST SHOPPING CART SERVICE, INC.	246113	08/23/2023	23-0023	SHOPPING CART RETRIEVAL SERVICES-JUL. 2023	\$5,124.00
Remit to: WEST COVINA, CA					FYTD: \$12,485.00
WEST COAST TURF	38133	08/16/2023	INV075734/RC0212	BULLSEYE SOD INSTALLED-HOUND TOWN DOG PARK (PER QUOTE Q000777)	\$9,875.43
Remit to: PALM DESERT, CA					FYTD: \$9,875.43

Attachment: August2023PaymentRegisterSR (6410 : AUGUST PAYMENT REGISTER 2023)



**City of Moreno Valley
Payment Register
For Period 8/1/2023 through 8/31/2023**

CHECKS UNDER \$25,000

<u>Vendor Name</u>	<u>Check/EFT Number</u>	<u>Payment Date</u>	<u>Inv Number</u>	<u>Invoice Description</u>	<u>Payment Amount</u>
WESTERN MUNICIPAL WATER DISTRICT	246163	08/30/2023	23821-018257 JLY	WATER CHARGES-MARCH FIELD PARK COMMUNITY CTR. LANDSCAPE	\$6,086.81
		08/30/2023	23821-018258 JLY	WATER CHARGES-MARCH FIELD PARK COMMUNITY CTR.-BLDG. 938	
		08/30/2023	23866-018292 JLY	WATER CHARGES-SKATE PARK	
		08/30/2023	24753-018620 JLY	WATER CHARGES-M.A.R.B. BALLFIELDS	
Remit to: ARTESIA, CA					<u>FYTD:</u> \$12,554.40
WESTERN RENEWABLE ENERGY GENERATION(WREGIS)	38019	08/02/2023	WR39117	RENEWABLE ENERGY CERTIFICATES-CREATED	\$0.34
Remit to: SALT LAKE CITY, UT					<u>FYTD:</u> \$0.34
WHITE, JERRY	246090	08/16/2023	2003520.047	ACCOUNT CREDIT REFUND	\$250.00
Remit to: MORENO VALLEY, CA					<u>FYTD:</u> \$250.00
WILLDAN ENGINEERING	38020	08/02/2023	00713844	PROJECT MANAGEMENT SERVICES-JUN. 2023/NSP CLOSEOUT, ETC.	\$2,172.50
		08/02/2023	00418798	ON-CALL CONSTRUCTION INSPECTION SERVICES - JUN. 2023	\$23,552.00
Remit to: ANAHEIM, CA					<u>FYTD:</u> \$397,873.22
WILLIAMS, TORI	246091	08/16/2023	2003521.047	ACCOUNT CREDIT REFUND	\$67.00
Remit to: MORENO VALLEY, CA					<u>FYTD:</u> \$67.00
WILMINGTON TRUST	38138	08/10/2023	W230802	DEBT SERVICE-STONERIDGE CFD NO. 5 SPECIAL TAXES 3RD	\$11,660.07
				INSTALLMENT	
Remit to: WILMINGTON, DE					<u>FYTD:</u> \$11,660.07
WIN-911 SOFTWARE	245951	08/02/2023	2361096078 1 YR	ANNUAL RENEWAL OF BASIC CUSTOMER CARE SUBSCRIPTION	\$800.00
Remit to: AUSTIN, TX					<u>FYTD:</u> \$800.00

Attachment: August2023PaymentRegisterSR (6410 : AUGUST PAYMENT REGISTER 2023)



City of Moreno Valley
Payment Register
For Period 8/1/2023 through 8/31/2023

CHECKS UNDER \$25,000

<u>Vendor Name</u>	<u>Check/EFT Number</u>	<u>Payment Date</u>	<u>Inv Number</u>	<u>Invoice Description</u>	<u>Payment Amount</u>
WOLTERS KLUWER	38248	08/30/2023	5414398526	PD FLYER STANDALONE MAINTENANCE RENEWAL 8/01/23-7/31/24	\$3,038.00
Remit to: TORRANCE, CA					FYTD: \$3,038.00
WSP USA, INC.	38088	08/09/2023	1328002	804 0008 SUNNYMEAD MDP LINE F AND F-7	\$7,559.32
Remit to: SAN BERNARDINO, CA					FYTD: \$42,556.46
YOUNG, CAROL	245994	08/09/2023	2003472.047	SECURITY GUARD REFUND-TOWNGATE COMMUNITY CENTER RENTAL	\$108.00
Remit to: MORENO VALLEY, CA					FYTD: \$338.50
ZAMORA, ERICK	246092	08/16/2023	REFUND-8/7/23	REFUND DISMISSED PARKING CITATIONS MVA030009986 & MVA030008650	\$287.50
Remit to: LOS ANGELES, CA					FYTD: \$287.50
ZECO SYSTEMS INC. DBA SHELL EV CHARGING SOLUTIONS	38135	08/16/2023	INV1907140	SKY NETWORK-DCFC & L2 5/12/22 - 5/11/23	\$2,240.02
	38249	08/30/2023	INV1907924	SKY NETWORK-DCFC & L2 5/12/23 - 5/11/24	\$2,240.02
Remit to: LOS ANGELES, CA					FYTD: \$4,480.04
TOTAL CHECKS UNDER \$25,000					\$1,492,755.68
GRAND TOTAL					\$36,503,440.80

Attachment: August2023PaymentRegisterSR (6410 : AUGUST PAYMENT REGISTER 2023)



Report to City Council

TO: Mayor and City Council

FROM: Brian Mohan, Assistant City Manager

AGENDA DATE: October 17, 2023

TITLE: DECLARING INTENTION TO ESTABLISH COMMUNITY FACILITIES DISTRICT 2023-01 (PUBLIC SAFETY SERVICES) OF THE CITY OF MORENO VALLEY AND TO AUTHORIZE THE LEVY OF A SPECIAL TAX THEREIN (RESO. NO. 2023-XX)

RECOMMENDED ACTION

Recommendations:

1. Adopt Resolution No. 2023-XX. A Resolution of the City Council of the City of Moreno Valley, California, Adopting Supplemental Local Goals and Policies for Community Facilities Districts to Fund Public Services.
2. Adopt Resolution No. 2023-XX. A Resolution of the City Council of the City of Moreno Valley, California, Declaring its Intention to Establish its Community Facilities District No. 2023-01 (Public Safety Services) and to Authorize the Levy of a Special Tax Therein.

SUMMARY

This report recommends the City Council takes the initial steps to establish City of Moreno Valley Community Facilities District No. 2023-01 (Public Safety Services) to provide a funding mechanism for ongoing public safety services. The services funded will include police protection services; fire protection and suppression services; and paramedic services, to the extent such services are in addition to services already provided.

DISCUSSION

As a condition of approval of development projects, the City requires developers to mitigate the cost of certain impacts created by the proposed development. Currently,

the ongoing costs of additional public safety service needed to serve new residential and non-residential development, are not matched with an ongoing revenue stream provided by the developer. However, the City is moving towards requiring that new development provide an ongoing funding source to cover the fiscal impact of public safety services.

The Mello-Roos Community Facilities Act of 1982 (the "Act"), offers the development community a tool to provide ongoing funding. Developers electing to use this tool would authorize the City to include their property in a Community Facilities District (a "CFD"). In connection with that CFD, the City then would levy an annual special tax to fund public safety services, collected on the annual property tax bill, against property in the development project.

Staff recommends establishing a new CFD, CFD No. 2023-01 (Public Safety Services) (the "District"), for this purpose. Fundable costs would include but are not limited to direct costs; salaries and benefits of staff; expenses related to equipment, apparatus, and supplies; and administrative and overhead costs for police protection services; fire protection and suppression services; and paramedic services. The two resolutions included would initiate the proceedings to establish that CFD.

The developer of Tract 38237 would like to use the District to satisfy its condition of approval. This will be the initial project to form the District. The formation process requires adoption of a Resolution of Intent. A Public Hearing to consider public testimony on the District's formation is tentatively scheduled for November 21, 2023.

The Resolution to adopt Supplemental Local Goals and Policies for Community Facilities Districts (CFD) to fund public services (Attachment 1) supplements the City's existing policies to make it clear that a CFD, as authorized by state law, can be used to fund public services unrelated to the maintenance and operation of physical infrastructure.

The Resolution of Intent (Attachment 2) describes the services that will be eligible to be funded by the District and sets forth the rate and method of apportionment of special tax (the "RMA"). The RMA assigns the formula to calculate the maximum special tax rate and outlines how the special tax is apportioned to properties annexed into the District. For example, the special tax rate for a single-family residential development is levied on a per unit basis. The special tax rate for non-residential development is based on square footage of building area.

The resolution calls the November 21, 2023 public hearing. At that hearing, the Council will have the opportunity to establish the CFD and to hold a landowner election to approve the tax to be levied in connection with the CFD. Assuming that the landowner submits its ballot during the November 21, 2023 meeting, the election can be closed and the ballot tabulated during the November 21, 2023 meeting.

It is the intent of staff that the CFD, once established, will be available to future developers for annexation. Assuming that the Council establishes the CFD, staff will

return to the Council with resolutions that enable property owners throughout the City to annex their territory to the CFD by consenting to such annexation (and without the need for an additional vote).

ALTERNATIVES

- 1) Adopt the Resolution to Adopt Supplemental Local Goals and Policies for Community Facilities Districts (CFD) and the Resolution of Intent to establish CFD No. 2023-01 (Public Safety Services). *Staff recommends this alternative since it will provide a revenue stream for operational impacts on public safety services relating to future residential and non-residential development and provide alternative and equitable funding options for the development community.*
- 2) Do not adopt the Resolutions but continue the items to a future Council meeting. *Staff does not recommend this alternative because it will delay the development community from satisfying their conditions of approval.*

FISCAL IMPACT

The proposed RMA has separate tax rates for residential and non-residential development. The maximum special tax is subject to an annual inflation adjustment based on the change in the Consumer Price Index (CPI) for All Urban Consumers for the Riverside-San Bernardino-Ontario Region as published by the Department of Labor's Bureau of Labor Statistics or five percent (5%), whichever is greater. However, the annual adjustment cannot be applied unless City Council approves an annual adjustment.

The maximum special tax for each tax rate has been calculated to achieve cost recovery for additional services required by new development. The maximum special tax rates cannot be increased beyond the annual inflationary adjustment without approval of the Qualified Electors (i.e. landowners or registered voters, depending upon the number of registered voters) who are subject to the tax. In the event revenues exceed expenditures for this program, the special tax rate applied to the property tax roll of those properties in the District will be less than the maximum special tax rate.

Third party costs associated with formation of the CFD are projected at \$30,000 for a special tax consultant, special legal counsel, legal notice publication costs, recording costs, and other related expenses. Sufficient funds exist in the City's FY 2023/24 Adopted Operating Budget of the Special Districts Administrative Fund 2006-30-79-25701.

NOTIFICATION

Newspaper advertising for the proposed November 21st, Public Hearing is scheduled to be published in The Press-Enterprise, consistent with the Act.

PREPARATION OF STAFF REPORT

Prepared By:
Felicia London
Special Districts Division Manager

Department Head Approval:
Brian Mohan
Assistant City Manager/CFO/City Treasurer

CITY COUNCIL GOALS

Revenue Diversification and Preservation. Develop a variety of City revenue sources and policies to create a stable revenue base and fiscal policies to support essential City services, regardless of economic climate.

Public Safety. Provide a safe and secure environment for people and property in the community, control the number and severity of fire and hazardous material incidents, and provide protection for citizens who live, work and visit the City of Moreno Valley.

CITY COUNCIL STRATEGIC PRIORITIES

- 1. Economic Development
- 2. Public Safety
- 3. Library
- 4. Infrastructure
- 5. Beautification, Community Engagement, and Quality of Life
- 6. Youth Programs

Objective 2.1: Reduce crime, the fear of crime, and the perception of crime in the community.

ATTACHMENTS

To view large attachments, please click your “bookmarks”  on the left hand side of this document for the necessary attachment.

- 1. Resolution to Adopt Goals and Policies
- 2. Resolution of Intent

APPROVALS

Budget Officer Approval	<u>✓ Approved</u>	10/09/23 9:54 AM
City Attorney Approval	<u>✓ Approved</u>	
City Manager Approval	<u>✓ Approved</u>	10/09/23 2:39 PM

RESOLUTION NO. 2023-_____

A RESOLUTION OF THE CITY COUNCIL OF THE CITY OF MORENO VALLEY, CALIFORNIA, ADOPTING SUPPLEMENTAL LOCAL GOALS AND POLICIES FOR COMMUNITY FACILITIES DISTRICTS TO FUND PUBLIC SERVICES

WHEREAS, the Mello-Roos Community Facilities Act of 1982 (Government Code Section 53311 *et seq.*) (the "Act") authorizes the City Council to establish Community Facilities Districts ("CFD's"); and

WHEREAS, the City and the Moreno Valley Community Services District have created numerous CFD's to fund public improvements and the maintenance of public improvements; and

WHEREAS, these CFD's help to ensure that costs associated with new developments are borne by the owners of property in those developments, rather than by the entire City; and

WHEREAS, CFD's can also be used to create an ongoing revenue stream to fund certain public services provided to properties in a CFD that are in addition to those provided in the territory before the CFD was created; and

WHEREAS, when new development causes an increased demand for public services, the services provided to meet that new demand are in addition to those provided prior to development; and

WHEREAS, Section 53312.7 of the Act requires that before initiating proceedings to establish a Financing District, the City Council must adopt local goals and policies regarding the use of the Act; and

WHEREAS, the City's existing local goals and policies do not clearly provide that the City may establish a CFD to fund public services that are not related to a public improvement; and

WHEREAS, the City Council desires to adopt local goals and policies with respect to the use of the Act to fund public services; and

WHEREAS, these new goals and policies will supplement existing local goals and policies.

NOW, THEREFORE, THE CITY COUNCIL OF THE CITY OF MORENO VALLEY, CALIFORNIA, DOES HEREBY RESOLVE AS FOLLOWS:

Resolution No. 2023-_____
Date Adopted: October 17, 2023

Attachment: Resolution to Adopt Goals and Policies (6415 : DECLARING INTENTION TO ESTABLISH COMMUNITY FACILITIES DISTRICT 2023-

Attachment "A"

- 1. Recitals. The recitals stated above are true and correct.
- 2. Adoption of Goals and Policies. The City Council hereby adopts the "Supplemental Goals and Policies for the use of the Mello-Roos Community Facilities Act of 1982 to fund Public Services" attached hereto as Attachment "A" and incorporated herein by reference.
- 3. Certification. The City Clerk shall certify to the adoption of this Resolution and shall maintain on file as a public record this Resolution.

APPROVED AND ADOPTED this 17th day of October, 2023

Mayor of the City of Moreno Valley

ATTEST:

City Clerk of the City of Moreno Valley

APPROVED AS TO FORM:

City Attorney

Resolution No. 2023-²
Date Adopted: October 17, 2023

Attachment: Resolution to Adopt Goals and Policies (6415 : DECLARING INTENTION TO ESTABLISH COMMUNITY FACILITIES DISTRICT 2023-

RESOLUTION JURAT

STATE OF CALIFORNIA)
COUNTY OF RIVERSIDE) ss.
CITY OF MORENO VALLEY)

I, Jane Halstead, City Clerk of the City of Moreno Valley, California, do hereby certify that Resolution No. 2023-___ was duly and regularly adopted by the City Council of the City of Moreno Valley at a regular meeting thereof held on the 17th day of October, 2023 by the following vote:

AYES:

NOES:

ABSENT:

ABSTAIN:

(Council Members, Mayor Pro-Tem and Mayor)

CITY CLERK

(SEAL)

Resolution No. 2023-___ 3
Date Adopted: October 17, 2023

City of Moreno Valley
 Supplemental Local Goals and Policies
 for the use of the
 Mello-Roos Community Facilities Act of 1982
 to Fund Public Services

Statement of Purpose

This document sets forth the goals and policies of the City of Moreno Valley concerning the use of the Mello-Roos Community Facilities Act of 1982 (the "Act") (Section 53311 *et seq.* of the California Government Code) to fund public services. It has been prepared pursuant to the requirements of Section 53312.7 of the Act.

Relation to Existing Goals and Policies

This document supplements, and does not supplant, any existing local goals and policies of the City with respect to the use of the Act.

Public Service CFD's Authorized

In addition to the priorities otherwise established by the local goals and policies of the City, the City Council may establish a Community Facilities District to fund any of the additional services authorized by Section 53313 of the Act.

No bonds shall be issued to finance such public services. As such, no appraisal is required pursuant to Section 53345.8 of the Act.

In order to ensure an equitable tax allocation, the rate of any special tax shall reflect (and shall not exceed) the cost of providing services to meet service demands that have result from the development of the property subject to the tax. The City shall not set a tax rate that is higher than permitted by law.

Interpretation

The City Council is empowered to interpret these goals and policies.

Amendment

These goals and policies may be amended from time to time by the City Council.

4
 Resolution No. 2023-
 Date Adopted: October 17, 2023

RESOLUTION NO. 2023-_____

A RESOLUTION OF THE CITY COUNCIL OF THE CITY OF MORENO VALLEY, CALIFORNIA, DECLARING ITS INTENTION TO ESTABLISH ITS COMMUNITY FACILITIES DISTRICT NO. 2023-01 (PUBLIC SAFETY SERVICES) AND TO AUTHORIZE THE LEVY OF A SPECIAL TAX THEREIN

WHEREAS, the Mello-Roos Community Facilities Act of 1982 (Government Code Section 53311 *et seq.*) (the “Act”) authorizes the City Council to establish a Community Facilities District (a “CFD”) to finance certain services; and

WHEREAS, among the services that may be financed by a CFD are police protection services; fire protection and suppression services; and paramedic services (collectively “Public Safety Services”); and

WHEREAS, when new development occurs in the City, the City’s public safety departments must provide Public Safety Services to the newly developed areas that exceed the amount of such services provided prior to development; and

WHEREAS, it is not desirable that the City’s general fund be burdened with the costs of these new services that are necessitated by new development; and

WHEREAS, the City Council desires to establish a CFD to fund these services; and

WHEREAS, a CFD can be established to serve a single new development, with the intent that future developments in the City that require additional Public Safety Services will be annexed into the CFD as they are developed; and

WHEREAS, the City has received a petition from the owner of a new development for the establishment of a CFD to fund Public Safety Services; and

WHEREAS, the City Council desires to initiate proceedings to establish that CFD;

NOW, THEREFORE, THE CITY COUNCIL OF THE CITY OF MORENO VALLEY, CALIFORNIA, DOES HEREBY RESOLVE AS FOLLOWS:

1. Recitals. The above recitals are all true and correct.
2. Initiation of Proceedings. The City Council proposes to establish a CFD pursuant to the Act.
3. Name of CFD. The CFD shall be designated “City of Moreno Valley Community Facilities District No. 2023-01 (Public Safety Services)” (“CFD No. 2023-01”).

1
Resolution No. 2023-_____
Date Adopted: October 17, 2023

Attachment: Resolution of Intent [Revision 3] (6415 : DECLARING INTENTION TO ESTABLISH COMMUNITY FACILITIES DISTRICT 2023-01

4. Boundaries of the CFD. For a description of the boundaries of the territory proposed for inclusion in CFD No. 2023-01, reference is made to the boundary map titled "Proposed Boundaries of City of Moreno Valley Community Facilities District No. 2023-01 (Public Safety Services), City of Moreno Valley, County of Riverside, State of California", which is on file in the office of the City Clerk, available for public inspection and incorporated herein by reference. A reduced copy of the boundary map is attached hereto as Exhibit A.

5. Description of Services. The following is a general description of the services (the "Services") to be provided:

Police protection services; fire protection and suppression services; and paramedic services, to the extent such services are in addition to services already provided at the time CFD No. 2023-01 is created and do not supplant existing services.

Fundable costs include, but are not limited to: (i) direct costs for such services, (ii) salaries and benefits of staff providing such services, (iii) expenses related to equipment, apparatus, and supplies related to these services, (iv) administrative and overhead costs, including staff time, associated with providing such services, and (v) lifecycle costs associated with the repair and replacement of facilities and improvements used to provide such services. Fundable costs also include the incidental expenses of the administration of CFD No. 2023-01.

6. Special Tax. Except where funds are otherwise available, a special tax sufficient to pay for the Services, secured by recordation of a continuing lien against all nonexempt real property in the district, will be annually levied within CFD No. 2023-01 (the "Special Tax"). Under no circumstances will the special tax levied in any fiscal year against any parcel be increased as a consequence of delinquency or default by the owner or owners of any other parcel or parcels within CFD No. 2023-01 by more than 10 percent above the amount that would have been levied in that fiscal year had there never been any such delinquencies or defaults. A complete description of the rate and method of apportionment of the Special Tax is attached hereto as Exhibit B and incorporated herein. The Special Tax will be collected in the same manner as ordinary ad valorem property taxes are collected and shall be subject to the same penalties and the same procedure, sale, and lien priority in case of delinquency as is provided for ad valorem taxes. Notwithstanding the forgoing, any Special Taxes that cannot be collected on the County tax roll, or are not so collected, may be collected through direct billing by the City.

7. Public Hearing. On November 21, 2023, at 6:00 PM (or as soon thereafter as practical), in the City Council Chambers located at 14177 Frederick Street, Moreno Valley, California 92553, the City Council will hold a public hearing on the establishment of CFD No. 2023-01. At the Hearing the testimony of all interested persons or taxpayers for or against the establishment of CFD No. 2023-01, the extent of CFD No. 2023-01, or the furnishing of specified types of public facilities or services will be heard. At the Hearing, protests against the establishment of CFD No. 2023-01, the extent of CFD No.

2
Resolution No. 2023-_____
Date Adopted: October 17, 2023

Attachment: Resolution of Intent [Revision 3] (6415 : DECLARING INTENTION TO ESTABLISH COMMUNITY FACILITIES DISTRICT 2023-01

2023-01, or the furnishing of specified types of services within CFD No. 2023-01 may be made in writing by any interested person or taxpayer. If a written majority protest against the establishment of CFD No. 2023-01 is filed (as determined in accordance with Section 53324 of the Act), the proceedings shall be abandoned. If such majority protest is limited to certain services or portions of the Special Tax, those services or that tax shall be eliminated by the City Council.

8. Election. Concurrently with, or subsequently to, the establishment of CFD No. 2023-01, the City Council may submit the levy of the Special Tax to the qualified electors of CFD No. 2023-01. The election will be conducted by the City Clerk of the City of Moreno Valley, as elections official. The vote will be by the landowners of CFD No. 2023-01, and each landowner of CFD No. 2023-01 who is the owner of record at the close of the Hearing, or is the authorized representative thereof, shall have one vote for each acre or portion of an acre of land that he or she owns within CFD No. 2023-01. The number of votes to be voted by a particular landowner will be specified on the ballot provided to that landowner. The election will be conducted by mail ballot. All time limits specified in Section 53326 of the Act and all requirements of law pertaining to the conduct of the election will be waived if the City receives both (i) unanimous consent to such waiver from the qualified electors of CFD No. 2023-01 and (ii) the concurrence of the City Clerk, as elections official.

9. Public Interest. Pursuant to Section 53329.5(c) of the Act, the City Council finds that the public interest will not be served by allowing property owners in CFD No. 2023-01 to enter into a contract pursuant to Section 53329.5(a) of the Act.

10. Report. The City Council directs the Special Districts Administrator to study the proposed CFD No. 2023-01 and, at or before the time of the Hearing, to file a report with the City Council containing the information required by Section 53321.5 of the Act.

11. This Resolution shall be effective immediately upon adoption.

12. The City Clerk shall cause the Boundary Map as approved to be filed in the Office of the County Recorder no later than fifteen (15) days after the date of adoption of this Resolution and shall give notice of the public hearing as required by law.

13. The City Clerk shall certify to the adoption of this Resolution, and shall maintain on file as a public record this Resolution.

3
Resolution No. 2023-_____
Date Adopted: October 17, 2023

Attachment: Resolution of Intent [Revision 3] (6415 : DECLARING INTENTION TO ESTABLISH COMMUNITY FACILITIES DISTRICT 2023-01

APPROVED AND ADOPTED this 17th day of October, 2023

Mayor of the City of Moreno Valley

ATTEST:

City Clerk of the City of Moreno Valley

APPROVED AS TO FORM:

City Attorney

Resolution No. 2023-4
Date Adopted: October 17, 2023

Attachment: Resolution of Intent [Revision 3] (6415 : DECLARING INTENTION TO ESTABLISH COMMUNITY FACILITIES DISTRICT 2023-01

RESOLUTION JURAT

STATE OF CALIFORNIA)
COUNTY OF RIVERSIDE) ss.
CITY OF MORENO VALLEY)

I, Jane Halstead, City Clerk of the City of Moreno Valley, California, do hereby certify that Resolution No. 2023-___ was duly and regularly adopted by the City Council of the City of Moreno Valley at a regular meeting thereof held on the 17th day of October, 2023 by the following vote:

AYES:

NOES:

ABSENT:

ABSTAIN:

(Council Members, Mayor Pro-Tem and Mayor)

CITY CLERK

(SEAL)

Resolution No. 2023- 5
Date Adopted: October 17, 2023

Attachment: Resolution of Intent [Revision 3] (6415 : DECLARING INTENTION TO ESTABLISH COMMUNITY FACILITIES DISTRICT 2023-01

EXHIBIT A

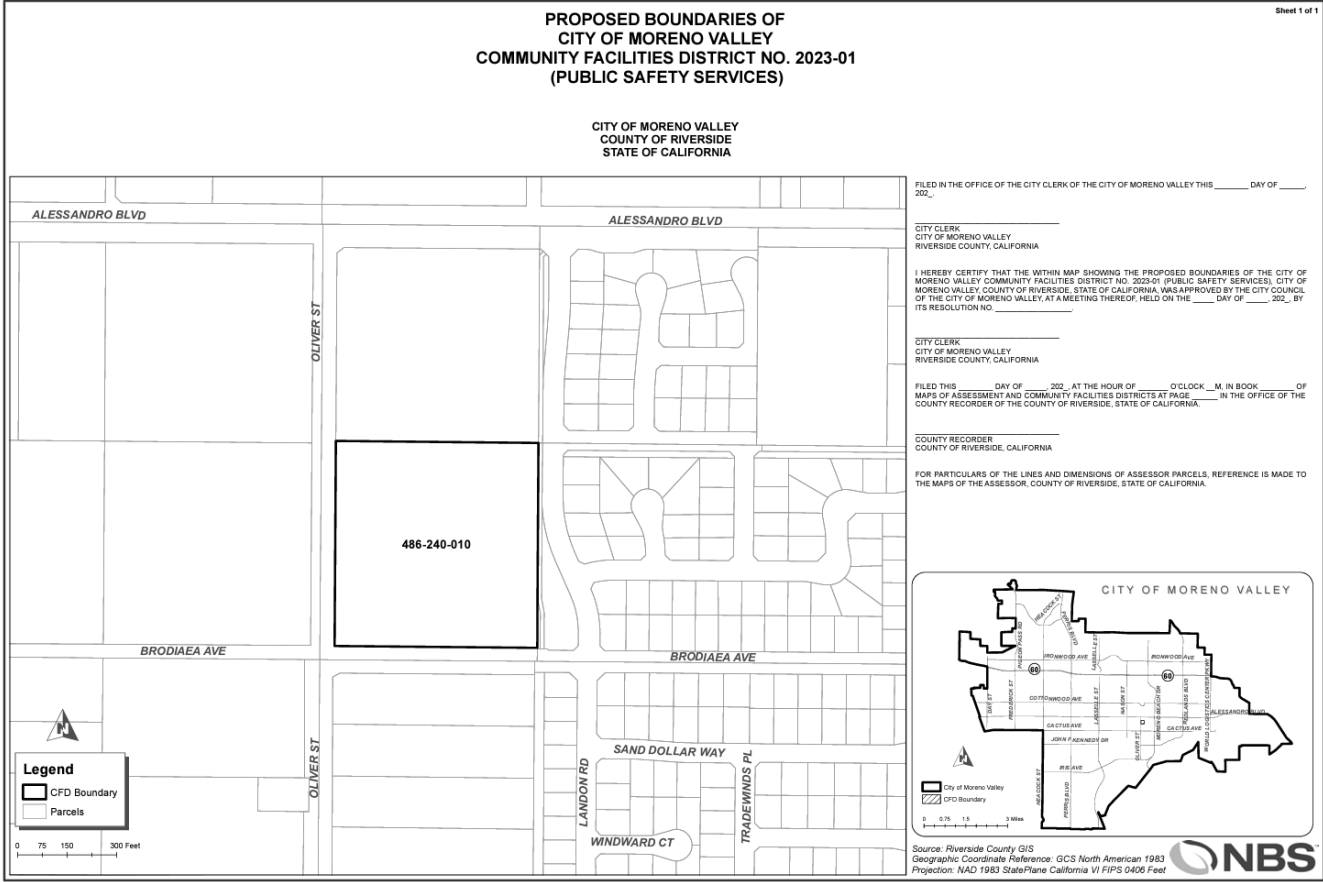

Attachment: Resolution of Intent [Revision 3] (6415 : DECLARING INTENTION TO ESTABLISH COMMUNITY FACILITIES DISTRICT 2023-01

EXHIBIT B

RATE AND METHOD OF APPORTIONMENT
FOR CITY OF MORENO VALLEY
COMMUNITY FACILITIES DISTRICT NO. 2023-01
(PUBLIC SAFETY SERVICES)

A Special Tax shall be levied and collected in City of Moreno Valley Community Facilities District No. 2023-01 (Public Safety Services) ("CFD No. 2023-01") each Fiscal Year, in an amount determined by the application of the procedures below. All of the Taxable Property (as defined below) in CFD No. 2023-01, unless exempted by law or by the provisions hereof, shall be taxed for the purposes, to the extent and in the manner herein provided.

A. DEFINITIONS

The terms hereinafter set forth have the following meaning:

"Accessory Dwelling Unit" or "ADU" means a secondary residential unit of limited size, as defined in California Government Code Section 65852.2, as may be amended from time to time, that is accessory to a single-unit dwelling. The ADU may be on the same Assessor's Parcel as the single-unit dwelling or on a separate Assessor's Parcel. For purposes of clarification, where an ADU and primary Unit are on the same Assessor's Parcel, the ADU located on such Assessor's Parcel is considered a separate Unit from the primary Unit on such Assessor's Parcel for purposes of the Special Tax. Should an Assessor's Parcel contain only an ADU, such Assessor's Parcel will be taxed as an ADU only.

"Acre or Acreage" means the land area of an Assessor's Parcel as shown on an Assessor's Parcel Map or in the Assessor's Data for each Assessor's Parcel. In the event the Assessor's Parcel Map or Assessor's Data shows no Acreage, the Acreage for any Assessor's Parcel shall be determined by the CFD Administrator based upon the applicable final map, parcel map, condominium plan, or other recorded County parcel map. If the preceding maps are not available, the Acreage of an Assessor's Parcel may be determined utilizing GIS.

"Act" means the Mello-Roos Community Facilities Act of 1982, as amended (California Government Code Sec. 53311 *et seq.*).

"Administrative Expenses" means the actual or reasonably estimated costs directly related to the administration of CFD No. 2023-01 including, but not limited to, the following: the costs of computing the Annual Special Tax Requirement and of preparing the Special Tax collection schedules; the costs of collecting the Special Tax, including any charges levied by the County Auditor's Office, Tax Collector's Office or Treasurer's Office; the costs of the City or designee in complying with the disclosure requirements under California law (including the Act), including public inquiries regarding the Special Tax; the costs of the City or designee related to an appeal of the Special Tax; and the costs of commencing and pursuing to completion any action arising from any delinquent Special Tax in CFD No. 2023-01.

"Annual Services Costs" means the amounts required to pay for the services authorized to be funded by CFD No. 2023-01.

Attachment: Resolution of Intent [Revision 3] (6415 : DECLARING INTENTION TO ESTABLISH COMMUNITY FACILITIES DISTRICT 2023-01

“Annual Special Tax Requirement” means that amount with respect to CFD No. 2023-01 determined by the City Council or designee as required in any Fiscal Year to pay: (1) the Administrative Expenses, (2) the Annual Services Costs, (3) any amount required to establish or replenish any reserve or replacement fund established in connection with CFD No. 2023-01, and (4) any reasonably anticipated delinquent Special Tax based on the delinquency rate for any Special Tax levied in the previous Fiscal Year.

“Assessor’s Data” means Units, Building Square Footage, Acreage, or other information contained in the records of the County Assessor for each Assessor’s Parcel.

“Assessor’s Parcel” or **“Parcel”** means a lot or parcel shown in an Assessor’s Parcel Map with an assigned Assessor’s Parcel Number.

“Assessor’s Parcel Map” means an official map of the Assessor of the County designating parcels by Assessor’s Parcel Number.

“Assessor’s Parcel Number” means, with respect to an Assessor’s Parcel, that number assigned to such Assessment’s Parcel by the County Assessor for purposes of identification.

“Building Square Foot(age)” means the structure square footage as shown on the building permit issued or as contained in the Assessor’s Data.

“CFD Administrator” means an official of the City, or designee thereof, responsible for determining the Annual Special Tax Requirement and providing for the levy and collection of the Special Taxes.

“CFD No. 2023-01” means the City of Moreno Valley Community Facilities District No. 2023-01 (Public Safety Services).

“City” means the City of Moreno Valley.

“City Council” means the City Council of the City, acting as the legislative body of CFD No. 2023-01.

“County” means the County of Riverside.

“County Assessor” means the County Assessor of the County.

“Developed Property” means, in any Fiscal Year, all Taxable Property in CFD 2023-01 that is (i) improved with one or more structures that were in place on March 1 of the preceding Fiscal Year and were built subsequent to the inclusion of the territory of the Taxable Property in CFD No. 2023-01, and/or (ii) property for which a building permit for new construction was issued by the applicable land use authority prior to March 1 of the preceding Fiscal Year.

“Final Subdivision Map” means a subdivision of property created by recordation of a final subdivision map, parcel map or lot line adjustment, approved by the City pursuant to the Subdivision Map Act (California Government Code Section 66410 *et seq.*) or recordation of a condominium plan pursuant to California Civil Code 4120, that creates individual lots for which building permits may be issued without further subdivision of such property.

“Fiscal Year” means the period starting July 1 and ending on the following June 30.

“GIS” means a geographic information system.

“Maximum Annual Special Tax” means the maximum Special Tax authorized to fund the Annual Special Tax Requirement in any Fiscal Year that may apply to Taxable Property as described in Section C.

“Mixed-Use Property” means all Assessor’s Parcels of Developed Property that is improved with (or has issued building permits for or has a combination of improvements and building permits for) more than one Property Type (whether in a single building or separate buildings). For an Assessor’s Parcel of Mixed-Use Property, each Property Type is subject to taxation pursuant to section C below.

“Multi-Family Residential Property” means all Assessor’s Parcels of Developed Property that either (i) include two or more Units (aside from ADUs, if any) or (ii) include only a single Unit of a larger structure that is part of condominium project as that term is defined in Civil Code Section 4125.

“Non-Residential Property” means all Assessor’s Parcel of Developed Property with commercial, industrial, institutional, office, hotel or other structures aside from Units (and aside from appurtenances to Units such as residential hallways, laundry rooms, mailrooms, residential lobbies, and the like).

“Property Owner’s Association” means any property owner’s association. As used in this definition, a Property Owner’s Association includes any home-owner’s association, condominium owner’s association, master or sub-association or non-residential owner’s association.

“Property Owner’s Association Property” means any property within the boundaries of CFD No. 2023-01 which is (a) owned by a Property Owner’s Association or (b) designated with specific boundaries and Acreage on a Final Subdivision Map as property owner association property.

“Property Type” means any of the land use categories listed in Table 1.

“Proportionately” means for Taxable Property that the ratio of the Special Tax levy to the Maximum Annual Special Tax is equal for all Assessors’ Parcels of Taxable Property levied within each Property Type within CFD No. 2023-01.

“Public Property” means any property within the boundaries of CFD No. 2023-01 which (i) is owned by a public agency, (ii) has been irrevocably offered for dedication to a public agency, or (iii) is designated with specific boundaries and Acreage on a Final Subdivision Map as property which will be owned by a public agency. For purposes of this definition, a public agency includes the federal government, the State, the County, the City, school districts, or any other public agency.

“Single Family Residential Property” means, in any Fiscal Year, all Assessor’s Parcels of Developed Property that (i) contains only one dwelling unit, aside from ADUs, if any, and (ii) is not classified as Multi-Family Residential Property.

“Special Tax” means the amount levied in each Fiscal Year on each Assessor’s Parcel of Taxable Property to fund the Annual Special Tax Requirement.

“State” means the State of California.

“Tax Escalation Factor” means the greater of the increase in the annual percentage change in the Consumer Price Index (CPI) for All Urban Consumers for the Riverside-San Bernardino-Ontario

County Region as published by the Department of Labor's Bureau of Labor Statistics or five percent (5%). If the CPI for the Riverside-San Bernardino-Ontario County area is discontinued, the CFD administrator may replace it with a similar index for the purposes of calculating the Annual Escalation Factor.

"Tax Zone" means a mutually exclusive geographic area within which the Special Tax may be levied pursuant to this Rate and Method of Apportionment. *All the Taxable Property within CFD No. 2023-01 at the time of its formation is within Tax Zone No. 1.* Additional Tax Zones may be created when property is annexed to CFD No. 2023-01, and a separate Maximum Annual Special Tax shall be identified for property within each new Tax Zone at the time of such annexation. The Assessor's Parcels included within a new Tax Zone when such Parcels are annexed to CFD No. 2023-01 shall be identified by Assessor's Parcel number in the annexation documents at the time of annexation.

"Taxable Property" means all of the Assessor's Parcels within the boundaries of CFD No. 2023-01 that are not exempt from the Special Tax pursuant to law or Section E below.

"Undeveloped Property" means all of the Assessor's Parcels within the boundaries of CFD No. 2023-01 that are not Developed Property.

"Unit" means any individual, townhome, condominium, apartment, including each separate living area within a half-plex, duplex, triplex, fourplex, or other residential structure. An Accessory Dwelling Unit on a Parcel of Single Family Residential Property shall be considered a separate Unit for purposes of calculating the Special Tax.

"Welfare Exempt Property" means, in any Fiscal Year, all Parcels within the boundaries of CFD No. 2023-01 that have been granted a welfare exemption by the County under subdivision (g) of Section 214 of the Revenue and Taxation Code.

B. DETERMINATION OF TAXABLE PARCELS

On, or about, July 1 of each Fiscal Year, the CFD Administrator shall determine the Annual Special Tax Requirement for that Fiscal Year and shall identify each parcel of Taxable Property within CFD 2023-01. The property type, APN and characteristics of each such parcel should be updated based on the most current information reasonably available to the CFD Administrator, and a tax amount determined for each parcel as set forth in Section C, below.

C. MAXIMUM ANNUAL SPECIAL TAX RATES

The Maximum Annual Special Tax for each Assessor's Parcel of Developed Property within Tax Zone No. 1 shall be assigned according to Table 1 below:

TABLE 1
MAXIMUM ANNUAL SPECIAL TAX RATES
TAX ZONE NO. 1 - FISCAL YEAR 2023/24*

Land Use Category	Maximum Annual Special Tax Rate	Per
Single Family Residential Property	\$242.00	Unit
Multi-Family Residential Property	206.00	Unit
Accessory Dwelling Unit	206.00	Unit
Non-Residential Property	56.00	1,000 Feet of Building Square Footage

*On each July 1, commencing on July 1, 2024, the Maximum Annual Special Tax Rate shall be increased by the Tax Escalation Factor.

Different Maximum Annual Special Tax rates and tax escalation factors may be identified in Tax Zones added to CFD No. 2023-01 as a result of future annexations.

Mixed-Use Property

In some instances, an Assessor's Parcel of Developed Property may contain more than one Property Type. The Maximum Annual Special Tax assigned to an Assessor's Parcel of Mixed-Use Property shall be the sum of the Maximum Annual Special Tax for each Property Types located on that Assessor's Parcel.

D. METHOD OF APPORTIONMENT OF THE SPECIAL TAXES

All Taxable Property shall be subject to the Special Tax. The Special Tax shall be levied each Fiscal Year by the CFD Administrator.

The Annual Special Tax Requirement shall be apportioned to each Parcel within CFD No. 2023-01 by the method shown below.

First: Determine the Annual Special Tax Requirement.

Second: Levy the Special Tax on each Parcel of Developed Property, Proportionately, up to the applicable Maximum Annual Special Tax.

Under no circumstances will the Special Taxes on any Assessor's Parcel of Developed Property be increased by more than 10% as a consequence of delinquency or default by the owner of any other Assessor's Parcel within CFD No. 2023-01.

No tax shall be levied on Undeveloped Property.

E. EXEMPTIONS

Notwithstanding any other provision of this Rate and Method of Apportionment of Special Tax, no Special Tax shall be levied on Property Owner's Association Property, Assessor's Parcels with public or utility easements making impractical their utilization for any use other than the purposes set

forth in the easement, or Public Property, except as otherwise provided in Sections 53317.3, 53317.5 and 533401 of the Act.

Welfare Exempt Property shall be exempt from the Special Tax in each Fiscal Year the property qualifies as Welfare Exempt Property.

F. APPEAL OF SPECIAL TAX LEVY

Any property owner may file a written appeal of the Special Tax with the CFD Administrator claiming that the amount or application of the Special Tax is not correct. The appeal must be filed not later than one calendar year after having paid the Special Tax that is disputed, and the appellant must be current in all payments of the Special Tax. In addition, during the term of the appeal process, all Special Tax levied must be paid on or before the payment date established when the levy was made.

The appeal must specify the reasons why the appellant claims the Special Tax is in error. The CFD Administrator shall review the appeal, meet with the appellant if the CFD Administrator deems necessary, and advise the appellant of its determination.

If the property owner disagrees with the CFD Administrator's decision relative to the appeal, the owner may then file a written appeal with the City Council whose subsequent decision shall be final and binding on all interested parties. If the decision of the CFD Administrator or subsequent decision by the City Council requires the Special Tax to be modified or changed in favor of the property owner, no cash refund shall be made for prior years' Special Taxes, but an adjustment shall be made to credit the Special Tax in future years.

This procedure shall be exclusive and its exhaustion by any property owner shall be a condition precedent to filing any legal action by such owner.

G. INTERPRETATIONS OF RATE AND METHOD OF APPORTIONMENT

The City reserves the right to make minor administrative and technical changes to this document that do not materially affect the rate and method of apportioning the Special Tax. In addition, the interpretation and application of any section of this document shall be at the City's discretion. Interpretations may be made by the City Council by ordinance or resolution for purposes of clarifying any vagueness or ambiguity in this Rate and Method of Apportionment of Special Tax.

H. MANNER AND DURATION OF SPECIAL TAX

The Special Tax shall be collected in the same manner and at the same time as ordinary ad valorem property taxes, provided that the City may directly bill the Special Tax, may collect the Special Tax at a different time or in a different manner if needed to meet the financial obligations of CFD No. 2023-01, and may collect delinquent Special Taxes through available methods.

A Special Tax shall be levied commencing in Fiscal Year 2024/25 to the extent necessary to satisfy the Annual Special Tax Requirement and shall be levied each Fiscal Year thereafter for as long as required to satisfy the Annual Special Tax Requirement, but for not longer than 500 years.

I. PREPAYMENT OF SPECIAL TAX

The Special Tax may not be prepaid.



Report to City Council

TO: Mayor and City Council
 Mayor and City Council Acting in its Capacity as
 President and Members of the Board of Directors of the
 Moreno Valley Community Services District (CSD)

FROM: Jeremy Bubnick, Parks & Community Services Director

AGENDA DATE: October 17, 2023

TITLE: APPROVE THE PUBLIC FACILITIES FEE CREDIT
 AGREEMENT WITH D.R. HORTON LOS ANGELES
 HOLDING COMPANY, INC. A CALIFORNIA
 CORPORATION, FOR PARKLAND IMPROVEMENTS IN
 TRACT 38236

RECOMMENDED ACTION

Recommendations: That the City Council and CSD:

Staff recommends that the Mayor and City Council and Mayor and City Council Acting in its Capacity as President and Members of the Board of Directors of the Moreno Valley Community Services District (CSD):

1. Approve the Public Facilities Fee Credit Agreement (“Agreement”) with D.R. Horton Los Angeles Holding Company, Inc. a California Corporation, for parkland improvements at Tract 38236 located north of Brodiaea Ave. and west of Oliver St.
2. Authorize the City Manager and the City Manager in the Capacity as Executive Director of the CSD to execute the Public Facilities Fee Credit Agreement with D.R. Horton Los Angeles Holding Company, Inc., for parkland improvements at Tract 38236 on behalf of the City and CSD subject to the approval by the City Attorney.

SUMMARY

This report recommends approval of a Public Facilities Fee Credit Agreement between the City of Moreno Valley, a Municipal Corporation, hereinafter (“City”), the Moreno

Valley Community Services District, hereinafter (“CSD”) and D.R. Horton Los Angeles Holding Company, Inc. a California Corporation, hereinafter (“D.R. Horton” or Developer”) for parkland improvements in Tract 38236. The Developer will use the fee credits to construct a 1.94-acre neighborhood park with amenities including a basketball court, playground structures, picnic shelter and tables, barbeque grill, hot coal receptacle, bench, bike rack, pet station, drinking fountain with dog station, cross trainer, set up bench, shoulder press and triple bar workout stations and park lighting.

DISCUSSION

The Moreno Valley General Plan specifies a parkland standard of three (3) acres per 1,000 of population, which is the minimum allowed by the Quimby Act, within the Subdivision Map Act, for residential subdivisions. As new residential developments occur within the City, it is essential to maintain the current park land standard to provide adequate parks and recreational opportunities for the community.

To maintain the parkland acreage standard, new residential developments may either dedicate improved park land to mitigate their impact to existing parks or they may pay a Quimby In-Lieu fee to provide funding for future parks and park improvements.

When D.R. Horton purchased approximately 26.74 acres to construct 202 single family residences, the Parks and Community Services staff negotiated with the Developer to construct a city park in exchange for Quimby In-Lieu and Parkland Development Impact Fee credits. Conditions of Approval for the improvements were drafted and are contained in the Conditional Use Permit for Tract 38236. The park amenities will include a basketball court, playground structures, picnic shelter and tables, barbeque grill, hot coal receptacle, bench, bike rack, pet station, drinking fountain with dog station, cross trainer, set up bench, shoulder press and triple bar workout stations and security lighting and landscaping.

The Public Facilities Fee Credit Agreement (PFF) will provide Quimby and Park Improvement Development Impact Fee (DIF) credit for each single-family home constructed within Tract 38236. Bonds for the park improvements and other amenities constructed within Tract 38236 will be collected by the City from the Developer.

Maintenance of the new park will have no impact on the general fund. It will be entered into the Parks and Landscape Services Division maintenance system, which is funded by Zone A and CFD 2021-01.

ALTERNATIVES

1. Approve the Public Facilities Fee Credit Agreement with D.R. Horton Los Angeles Holding Company, Inc. a California Corporation, for parkland improvements at Tract 38236 and authorize the City Manager and City Manager in the Capacity as Executive Director to the CSD to approve the Agreement upon review and approval by the City Attorney.

2. Elect not to approve the Public Facilities Fee Credit Agreement with D.R. Horton Los Angeles Holding Company, Inc. a California Corporation, for parkland improvements at Tract 38236, and provide further direction to staff.

FISCAL IMPACT

None.

NOTIFICATION

Posting of the agenda.

PREPARATION OF STAFF REPORT

Prepared By:
Sharon Goodale
Management Analyst

Department Head Approval:
Jeremy Bubnick
Parks and Community Services Director

Concurred By:
Patty Yhuit
PCS Administration & Financial Services Division Manager

Concurred By:
Daniel Monto
Parks and Landscape Services Division Manager

CITY COUNCIL GOALS

Public Facilities and Capital Projects. Ensure that needed public facilities, roadway improvements, and other infrastructure improvements are constructed and maintained.

Positive Environment. Create a positive environment for the development of Moreno Valley's future.

Community Image, Neighborhood Pride and Cleanliness. Promote a sense of community pride and foster an excellent image about our City by developing and executing programs which will result in quality development, enhanced neighborhood preservation efforts, including home rehabilitation and neighborhood restoration.

CITY COUNCIL STRATEGIC PRIORITIES

1. Economic Development
2. Public Safety
3. Library
4. Infrastructure
5. Beautification, Community Engagement, and Quality of Life
6. Youth Programs

Objective 5.2: Promote the installation and maintenance of cost effective, low maintenance landscape, hardscape and other improvements which create a clean, inviting community.

Objective 5.5: Promote a healthy community and lifestyle.

Objective 6.2: Improve health, wellness and fitness for Moreno Valley youth through recreation and sports programs.

ATTACHMENTS

To view large attachments, please click your “bookmarks”  on the left hand side of this document for the necessary attachment.

- 1. Public Facilities Fee Credit Agreement
- 2. Tract 38236 Park Imp Plans

APPROVALS

Budget Officer Approval	<u>✓ Approved</u>	10/09/23 8:52 AM
City Attorney Approval	<u>✓ Approved</u>	
City Manager Approval	<u>✓ Approved</u>	10/09/23 9:03 AM

PUBLIC FACILITIES FEE CREDIT AGREEMENT TENTATIVE TRACT MAP 38236 (PEN21-0184) AND CUP (PEN22-0091)

This Public Facilities Fee Credit Agreement ("PFF Agreement") is entered into between The City of Moreno Valley ("City"), the Moreno Valley Community Services District ("CSD) and D.R. Horton Los Angeles Holding Company, Inc. a California Corporation, ("D.R. Horton") as of September 5, 2023, ("the Effective Date"), and sets forth the understanding of City, CSD, and D.R. Horton with respect to the following:

1. Recitals.

1.1 Whereas, D.R. Horton is the owner of that certain real property known as Tract 38236 (consisting of approximately 30 acres) in the City of Moreno Valley, County of Riverside, California (the "Project" or "Tract 38236"); and

1.2 Whereas, Tentative Tract Map 38236 (PEN21-0184) and CUP (PEN22-0091) approved by the Planning Commission on July 28, 2022, is subject to certain development impact fees and/or public facilities fees(hereinafter "Public Facilities Fees" or "PFF"), for Quimby Park Land and DIF Parkland Facilities, and in accordance with applicable City ordinances, the current amount of which is \$6,924.75 per lot (\$2,302.00 Quimby Park Land fee and \$4,622.75 DIF Parkland Facilities fee); and

1.3 Whereas, this agreement between the City, the CSD and D.R. Horton, relative to the development known as Tract 38236 provides Quimby Park Land and DIF Parkland Facilities Improvement credits for 202 lots in the amount of \$6,924.75 per lot against such Public Facilities Fees ("PFF Credit") (total credit \$1,398,799.50), subject to D.R. Horton's satisfaction of its obligation to complete certain park improvements pursuant to the Conditions of Approval for Tentative Tract Map 38236 (PEN21-0184) and CUP (PEN22-0091).

1.4 Whereas, City, CSD and D.R. Horton have reached an understanding as to the terms of this PFF Agreement, specifically that the City shall apply the \$6,924.75 per lot credit for 202 lots against the Public Facilities Fees in effect at the time each of the mutually agreed upon 202 building permits are issued; and

Now, therefore, City, CSD and D.R. Horton, in consideration of their respective commitments below, agree as follows:

2. Timing and Payment of Public Facilities Fees:

2.1 Subject to D.R. Horton's satisfaction of its obligation to complete certain park improvements pursuant to the Conditions of Approval for Tentative Tract Map 38236

**PUBLIC FACILITIES FEE CREDIT AGREEMENT
TENTATIVE TRACT MAP 38236 (PEN21-0184) AND CUP
(PEN22-0091)**

(PEN21-0184) and CUP (PEN22-0091), D.R. Horton shall receive the PFF credit against the City's Public Facilities Fees (Quimby Park Land and Parkland Facilities) for 202 lots at the time these building permits are pulled. The PFF Credit shall reduce Public Facilities Fee by \$1,398,799.50 (\$6,924.75 per single family unit on a total of 202 lots). In the event the Public Facilities Fee exceeds \$6,924.75 per single family unit the PFF Credit shall be adjusted to fully satisfy the Public Facilities Fee in effect at the time the applicable building permits are issued; provided, however, in no event shall the PFF Credit exceed the cost or valuation of the improvements and/or dedications.

3. Enforcement.

3.1 Enforcement by Either Party. The City and CSD agrees that unless this PFF Agreement is amended or terminated by mutual agreement of City, CSD and D.R. Horton, this PFF Agreement shall be enforceable by any party hereto notwithstanding any change hereafter in any applicable General Plan, Specific Plan, City Ordinance, Rule or Regulation.

3.2 The Cumulative Remedies. In addition to any other rights or remedies, either party may institute a legal action to cure, correct or remedy any default, to enforce any covenant or agreement herein, or to enjoin any threatened or attempted violation, including suits for declaratory relief, specific performance, relief in the nature of mandamus and actions for damages. All the remedies described above shall be cumulative and not exclusive to one another, and the exercise of any one or more of the remedies herein shall not constitute a waiver or election with respect to any other available remedy.

3.3 Attorneys' Fees. In any arbitration, administrative proceedings, or any action in any courts of competent jurisdiction, brought by one or more parties to enforce any provision of this PFF Agreement, or to enforce any rights or remedies under this PFF Agreement, including any action for declaratory or equitable relief, the prevailing party shall be entitled to reasonable attorneys' fees and all reasonable costs, expenses and disbursements in connection with such action.

4. Miscellaneous Provisions.

**PUBLIC FACILITIES FEE CREDIT AGREEMENT
TENTATIVE TRACT MAP 38236 (PEN21-0184) AND CUP
(PEN22-0091)**

4.1 Covenants, Conditions and Restrictions. The terms of this PFF Agreement shall be binding upon the parties, their successors and assigns. Any successor in interest of D.R. Horton may enforce the provisions of this PFF Agreement.

4.2 Other Agreements. This PFF Agreement is not intended to alter the obligations of the parties under any other contracts existing between them, save and except as set forth in Section 2.1 above, whether signed before, after or in conjunction with this PFF Agreement intended to alter D.R. Horton's obligations under any existing conditions of approval applicable to Tract 38236.

4.3 Entire Agreement. This PFF Agreement constitutes the entire agreement between the parties with respect to the subject matter of this PFF Agreement.

4.4 Governing Law. This PFF Agreement, including, without limitation, its existence, validity, construction and operation, and the rights of each of the parties hereunder, shall be determined in accordance with the laws of the State of California.

4.5 Recitals. The recitals in this PFF Agreement constitute part of this PFF Agreement and each party shall be entitled to rely on the truth and accuracy of each recital as an inducement to enter into this PFF Agreement.

4.6 Time. Time is of the essence for this PFF Agreement and for each and every term and condition hereof.

4.7 No Third Party Beneficiaries. This PFF Agreement is made and entered into for the sole protection and benefit of the parties and their successors and assigns. Except as expressly provided in this PFF Agreement, no other person shall have any rights or cause of action based upon any provision of this PFF Agreement.

4.8 Waiver. The failure of either party at any time to seek redress for any violation of this PFF Agreement, or to insist upon the strict performance of any term or condition of this PFF Agreement, shall not prevent any subsequent act or omission of the same or similar nature from having all the force and effect of the original breach or default, and such subsequent act or omission may be proceeded against by either party to the fullest extent provided by this PFF Agreement. No provision of this PFF Agreement shall be deemed to have been waived by either party unless the waiver is in writing and is signed by the party waiving its rights or claims.

**PUBLIC FACILITIES FEE CREDIT AGREEMENT
TENTATIVE TRACT MAP 38236 (PEN21-0184) AND CUP
(PEN22-0091)**

4.9 Binding Effect. The covenants and agreements contained in this PFF Agreement shall insure to the benefit of and shall be binding upon each of the parties and their respective heirs, administrators, successors and assign.

4.10 Prevailing Wages. D.R. Horton acknowledges the provisions of California Labor Code, Division 2, Part 7, regarding the payment of prevailing wage rates for public works and in particular the fact that Section 1720 therein applies certain regulations under such statutes to private projects receiving certain public benefits; and that neither the City, CSD nor any person with authority to bind the City or CSD has made any representation as to any requirement, or any exemption from any requirement, to pay prevailing wages thereunder. D.R. Horton accepts all responsibility for determining the applicability of prevailing wage laws and any other law, rule, regulation or other obligation with respect to its employees, subcontractors, or any other person and for the amounts paid to any of its employees, subcontractors, or any other person.

5. Defense of the City and CSD.

5.1 D.R. Horton shall defend, indemnify, and hold harmless the City and CSD, including but not limited to paying all costs associated therewith, in any claim brought against this PFF Agreement. If the City and/or CSD is determined to be the "prevailing party" in any such litigation, and is awarded its attorneys' fees and costs by the Court, then such award shall be promptly paid to D.R. Horton as reimbursement for the attorneys' fees and costs it incurred in providing the City and/or CSD with a defense provided however, the City and/or CSD shall retain any portion of attorney's fees that it directly incurred.

5.2 **INDEMNIFICATION**

a. D.R. Horton shall defend, indemnify and hold harmless the City and CSD, its officers, officials, agents, employees and volunteers from and against any and all claims, demands, actions, losses, damage, injuries, and liability, direct or indirect, (including any and all costs and expenses in connection therewith), to the extent arising out of the acts or omissions of D.R. Horton in performance of this Agreement, except for any such claim arising out of the sole negligence or willful misconduct of the City and/or CSD, its officers, agents, employees or volunteers.

b. The City and the CSD does not, and shall not; waive any rights that it may

**PUBLIC FACILITIES FEE CREDIT AGREEMENT
TENTATIVE TRACT MAP 38236 (PEN21-0184) AND CUP
(PEN22-0091)**

have against D.R. Horton under this section because of the acceptance by the City or CSD, or the deposit with the City or CSD, of any insurance policy or certificate required pursuant to this Agreement. The hold harmless, indemnification and duty to defend provisions of this section shall apply regardless of whether or not said insurance policies are determined to be applicable to the claim, demand, action, damage, liability, loss, cost or expense described herein.

c. Notwithstanding the provisions of subsections a. and b. of this section, D.R. Horton shall not be responsible for damages or be in default or deemed to be in default by reason of delay caused by strikes, lockouts, accidents, or acts of God, or the failure of the City and/or CSD to furnish timely information or to approve or disapprove D.R. Horton's work promptly, or by reason of delay or faulty performance by the City and/or CSD, construction contractors, or governmental agencies, or by reason of any other delays beyond D.R. Horton's control, or for which D.R. Horton is without fault.

d. The indemnity provisions contained in this Section shall survive expiration or sooner termination of this Agreement.

6. Additional Terms

6.1 **Authority To Execute.** The representative executing this Agreement on behalf of each party hereby represents and warrants that he or she has full power and authority to execute this Agreement on behalf of such party and that all approvals and other actions necessary in connection with the effective execution by him or her have been obtained and are in full force and effect as of his or her execution hereof.

6.2 **Civil Code Section 1542 Waiver.**

a. Subject to and upon receipt of the PFF Credit pursuant to this PFF Agreement, D.R. Horton expressly waives any and all rights and benefits conferred upon it by the provisions of Section 1542 of the California Civil Code which reads as follows:

"A general release does not extend to claims that the creditor or releasing party does not know or suspect to exist in his or her favor at the time of executing the release and that, if known by him or her, would have materially affected his or her settlement with the debtor or released party."

PUBLIC FACILITIES FEE CREDIT AGREEMENT TENTATIVE TRACT MAP 38236 (PEN21-0184) AND CUP (PEN22-0091)

b. This waiver shall be effective as a bar to any and all actions, fees, damages, losses, claims, liabilities and demands of whatsoever character, nature and kind that are known or unknown, or suspected or unsuspected to the extent arising out of this PFF Agreement, including, without limitation, claims of entitlements under the California Public Employees' Retirement System (CalPERS) that are only afforded to employees and not independent contractors. Developer further represents and warrants that it understands this waiver and that if it does not understand this waiver, it shall seek the advice of a qualified attorney before executing this Agreement.

IN WITNESS WHEREOF, the parties have duly executed this PFF Agreement as of the date and year specified above as the Effective Date.

CITY OF MORENO VALLEY/ MORENO VALLEY COMMUNITY SERVICES DISTRICT

By _____
Mike Lee, City Manager/Executive Director of the Moreno Valley Community Services District

ATTESTED TO:

By _____
Jane Halsted, City Clerk

APPROVED AS TO FORM:
By Daniel Trevino
Steve Quintana, City Attorney
Daniel Trevino, Deputy City Attorney

D.R. Horton Los Angeles Holding
Company, Inc. a California Corporation

DocuSigned by:
By Vicki Gullion
Vicki Gullion, Assistant Secretary

Attachment: Public Facilities Fee Credit Agreement (6417 : THE PUBLIC FACILITIES FEE CREDIT AGREEMENT WITH D.R. HORTON LOS

CERTIFICATE OF ASSISTANT SECRETARY

The undersigned hereby certifies as follows:

1. She is a duly elected, qualified and acting Assistant Secretary of D.R. Horton Los Angeles Holding Company, Inc., a California corporation (*the "Company"*), is familiar with the facts herein certified and is duly authorized to certify the same.
2. The following are true, correct and complete copies of resolutions related to the subject matter as adopted by the Consent of Sole Director of the Company dated April 2, 2019 (*the "Resolutions"*). The Resolutions have not been amended, rescinded or modified and remain in full force and effect as of the date hereof.

Election of Assistant Secretary and Assistant Forward Planning Manager

RESOLVED, that Vicki Gullion is hereby elected to the office of Assistant Secretary of the Company (*the "Assistant Secretary"*) in the Company's Southern California Division (*the "Division"*), to serve until the next annual meeting of the directors of the Company and until her successor is duly elected and qualified or until her earlier death, resignation or removal.

RESOLVED FURTHER, that the Assistant Secretary is hereby authorized and empowered, in the North area (*the "Area"*) of the Division and in the name and on behalf of (i) the Company, (ii) any partnership of which the Company is a general partner, manager or agent, and (iii) any limited liability company of which the Company is a member, manager or agent (*collectively, the "Entities"*), to sign, modify and terminate, from time to time as she deems it to be in the best interest of the Entities, homeowner association documents, CC&Rs, subdivision agreements, utility agreements, condominium plans, all agency applications relating to development, consultant agreements, maps and other similar or equivalent agreements or documents for the Area relating to the business of the Entities.

RESOLVED FURTHER, that the Assistant Secretary is hereby authorized on behalf of the Entities to sign, modify and terminate, from time to time as she deems it to be in the best interest of the Entities, various agreements and documents for the Area including, but not limited to, conditions, subcontract agreements, general contract agreements, bonds, building permits, improvement/development agreements and other similar or equivalent agreements or documents for the Area relating to the business of the Entities.

IN WITNESS WHEREOF, the undersigned has signed on the 11th day of April, 2019.

 Ashley Dagley
 Assistant Secretary

PUBLIC PARK IMPROVEMENT PLANS

CITY OF MORENO VALLEY
TR. 38236
CITY OF MORENO VALLEY PARKS AND COMMUNITY SERVICES



TR. 38236 STELLA POINTE & BELLA SERA DR HORTON

2280 WARDLOW CIRCLE, SUITE 100 CORONA, CA 92878
PHONE: (951) 739-5485 CONTACT: MEGAN WHIELDON

LANDSCAPE QUANTITIES:

TOTAL PARK SITE ACREAGE: 1.8 ACRES

HARDSCAPE:

- CONCRETE SF = 16,280 SF
- BASKETBALL COURT WITH PLEXIPAVE SF = 4,200 SF
- EXERCISE SURFACING = 1,585 SF
- MULCH AT PLAYGROUND = 5,645 SF

PLANTING:

- TURF SF = 33,936 SF
- SHRUB & GROUND COVER AREA = 16,883 SF
- TREES = 70 TOTAL

AMENITIES:

- SHADE STRUCTURE
- BENCH
- PICNIC TABLE
- PICNIC TABLE (ADA)
- WASTE RECEPTACLE
- BBQ GRILL
- HOT COAL RECEPTACLE
- BIKE RACK
- DRINKING FOUNTAIN W/ PET STATION
- PET WASTER STATION
- PARK RULES SIGN
- PLAY STRUCTURE AGES 2-5
- PLAY STRUCTURE AGES 5-12

QTY
1
2
8
2
10
1
1
1
3
2
4
1
1

CONSULTANTS:



CIVIL
ADKAM ENGINEERS
6879 AIRPORT DRIVE
RIVERSIDE, CA 92504
PHONE: 951-688-0241

VICINITY MAP

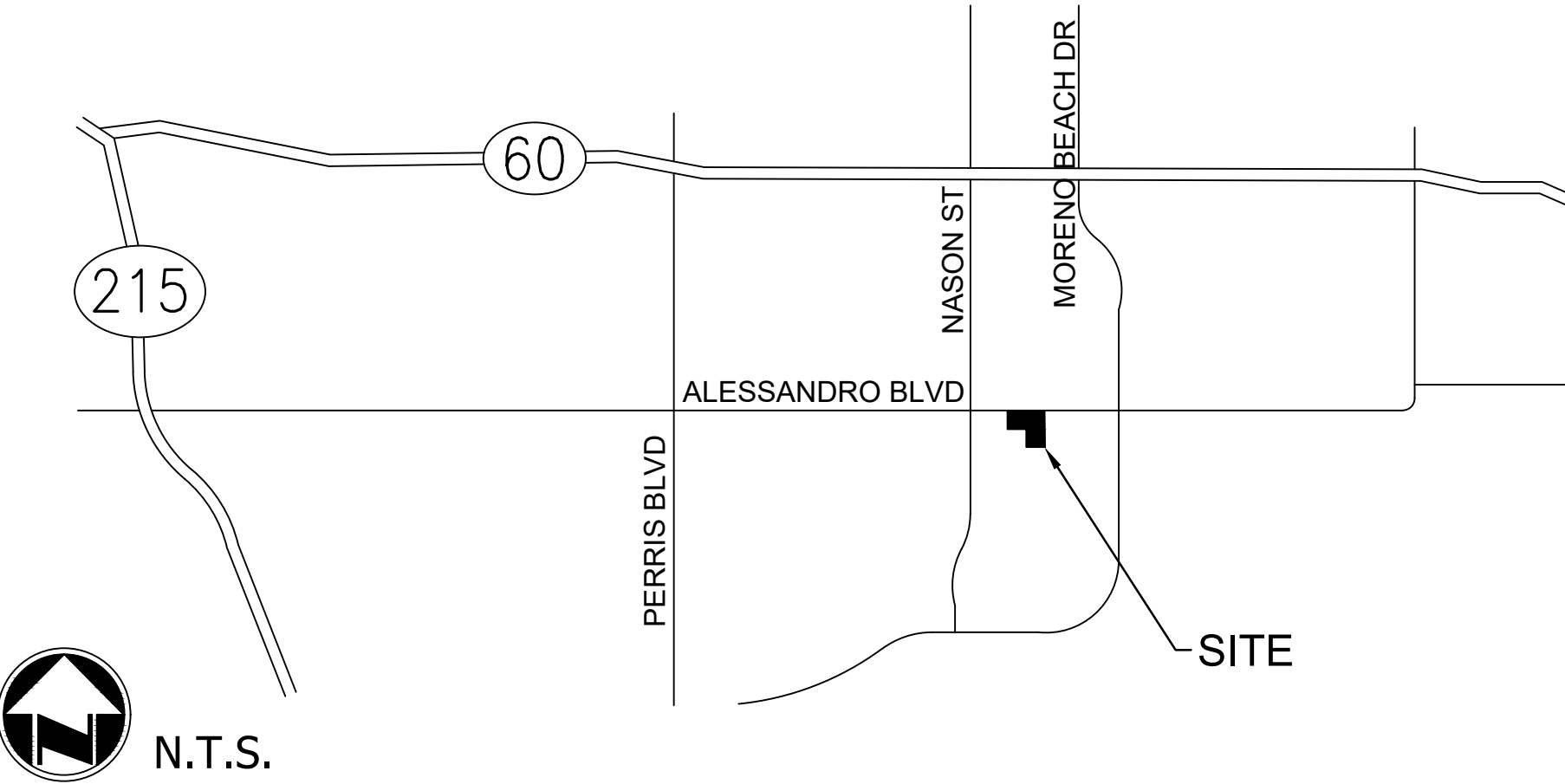

SITE INDEX

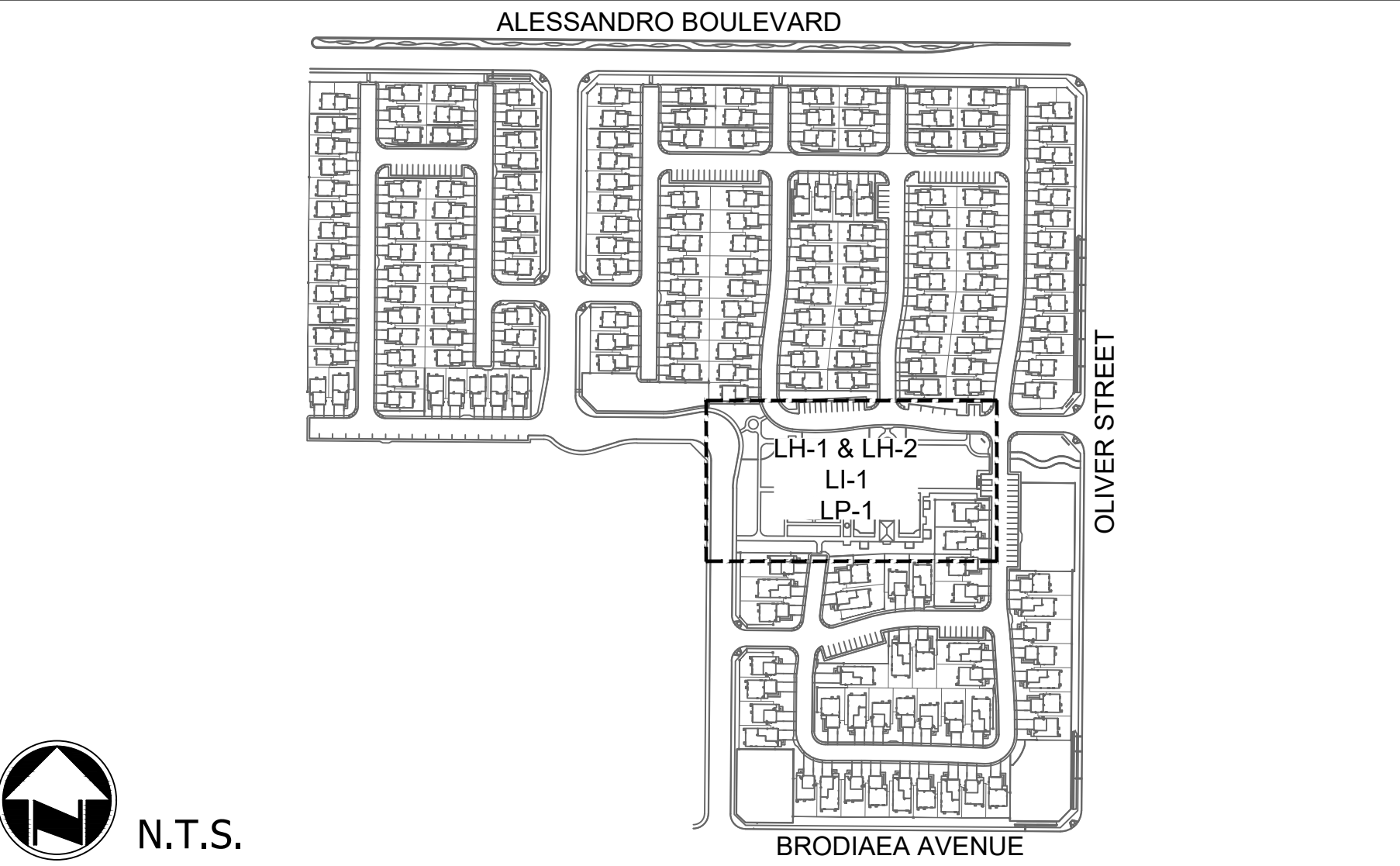

GENERAL NOTES:

DEPARTMENT OF PARKS AND COMMUNITY SERVICES GENERAL NOTES:

- ALL WORK SHALL BE DONE IN ACCORDANCE WITH THE MOST RECENT VERSIONS (AT TIME OF CONSTRUCTION) OF: THE CITY OF MORENO VALLEY PARK AND COMMUNITY SERVICES LANDSCAPE DEVELOPMENT GUIDELINES, SPECIFICATIONS, DRAWINGS, GREENBOOK SPECIFICATIONS FOR PUBLIC WORKS PROJECTS, AND THE CALIFORNIA BUILDING CODE.
- TURF AREAS SHALL HAVE A MAXIMUM DESIGN SLOPE OF 20% AND A MINIMUM DESIGN OF 1%.
- ALL CONCRETE SHALL ADHERE TO THE "GREENBOOK" FOR ITS SPECIFIC TYPE OF APPLICATION. MINIMUM REQUIREMENTS ARE 2500 PSI WITH NO SUBSTITUTES FOR PORTLAND CEMENT. COLOR AND FINISH SAMPLES SHALL BE PROVIDED TO THE PARKS AND COMMUNITY SERVICES PROJECT MANAGER FOR APPROVAL PRIOR TO INSTALLATION. PUMP MIXES SHALL BE 3250 PSI.
- CONTRACTOR/DEVELOPER SHALL PROVIDE A 12" W/ REINFORCED CONCRETE MOW STRIP BETWEEN TURF AND GROUND COVER AND A 12" CONCRETE MOW STRIP BETWEEN TURF AND WALLS, UNLESS SPECIFICALLY AUTHORIZED OTHERWISE BY PARKS AND COMMUNITY SERVICES.
- THE CONTRACTOR IS RESPONSIBLE FOR OBTAINING GRADING AND BUILDING PERMITS FOR CITY FUNDED PROJECTS. CONSTRUCTION PARKS AND COMMUNITY SERVICES WILL OBTAIN BUILDING PERMITS FOR CITY FUNDED PROJECTS.
- THE CONTRACTOR MUST NOTIFY THE PARKS AND COMMUNITY SERVICES PROJECT MANAGER AND THE BUILDING AND SAFETY DIVISION A MINIMUM OF TWO (2) WORKING DAYS (MONDAY - FRIDAY, EXCLUDING HOLIDAYS) PRIOR TO COMMENCING CONSTRUCTION AND/OR INSPECTION.
- ALL CONSTRUCTION WORK SHALL BE PERFORMED MONDAY THROUGH FRIDAY (EXCLUDING HOLIDAYS), BETWEEN THE HOURS OF 7 AM AND 4 PM. ANY EXCEPTIONS TO THIS SCHEDULE MUST BE APPROVED IN WRITING FROM PARKS AND COMMUNITY SERVICES.
- LANDSCAPE OR IRRIGATION CONTRACTOR SHALL VERIFY EXISTING WATER PRESSURE AT THE JOB SITE PRIOR TO INSTALLING LANDSCAPE IRRIGATION SYSTEM. A GAUGE THAT RECORDS MAINLINE PRESSURE AND FLOW IS REQUIRED FOR 24 HOURS 1 DAY PERIOD.
- A MAINLINE TEST (IRRIGATION AND PORTABLE WATER) AT 150 PSI FOR 4 HOURS SHALL BE SCHEDULED WITH PARKS AND COMMUNITY SERVICES. IF WATER PRESSURE IS LESS THAN DESIGNED PRESSURE, THE CONTRACTOR WILL CONTACT THE ARCHITECT REGARDING THE FINDINGS AND WILL CEASE IRRIGATION WORK UNTIL A SOLUTION IS PROVIDED AND APPROVED IN WRITING BY THE PARKS AND COMMUNITY SERVICES PROJECT MANAGER. MAINLINE TESTS MUST HAVE ALL APPURTENANCES ATTACHED (VALVES, UNIONS, ETC.)
- THE CONTRACTOR IS RESPONSIBLE FOR INSTALLING AN IRRIGATION SYSTEM THAT PROVIDES COMPLETE COVERAGE TO PLANT MATERIAL IN A MATURE STAGE. IRRIGATION MODIFICATIONS MAY BE REQUIRED TO KEEP WATER OFF OF LIGHT FIXTURES, DRINKING FOUNTAINS, PLAY EQUIPMENT, PICNIC AREAS, STRUCTURES, FENCINGS, SIDEWALKS, ETC.
- AT THE CONCLUSION OF ROUGH GRADING, AGRONOMIC SOILS TESTING SHALL BE PROVIDED FOR THE PUBLIC LANDSCAPED AREA AND AREAS THAT ARE ADJACENT TO PUBLIC RIGHT-OF-WAY AND THE RESULTS APPROVED BY PARKS AND COMMUNITY SERVICES, PRIOR TO ANY LANDSCAPE INSTALLATION.
- A COMPREHENSIVE SOILS TEST IS REQUIRED PRIOR TO PLACING ANY CONCRETE (PCC OR AC) AND BACK FILLED TRENCHES. THIS WILL BE USED TO DETERMINE THE CONCRETE DESIGN AND NECESSITY OF ADDITIONAL BASE MATERIALS ABOVE THE DESIGN ON THE PLANS AND CITY STANDARDS. THE PLAN DESIGN AND CITY STANDARDS SHALL SET THE MINIMUM STANDARDS.
- ALL LOAD TICKETS OR RECEIPTS SHALL BE PROVIDED TO PARKS AND COMMUNITY SERVICES WITHIN 24 HOURS OF RECEIPT OF PRODUCT. COPIES OF LOAD TICKETS/ RECEIPTS INCLUDE BUT ARE NOT LIMITED TO CONCRETE, SOIL AND LANDSCAPE PRODUCTS, PLANT MATERIAL, FENCINGS AND BUILDING MATERIALS.
- ALL "SUBMITTALS" AND SHOP DRAWINGS SHALL BE PROVIDED TO PARKS AND COMMUNITY SERVICES WITHIN THE FIRST 30-DAYS OF THE AWARD OF CONTRACT.
- ALL MATERIALS SHALL BE AS SPECIFIED WITHIN THE PLANS AND SPECIFICATIONS. "EQUALS OR SUBSTITUTIONS" WILL ONLY BE CONSIDERED WITHIN THE FIRST 30-DAYS AFTER THE AWARD OF CONTRACT. THE PARKS AND COMMUNITY SERVICES PROJECT MANAGER SHALL APPROVE IN WRITING ALL EQUALS OR SUBSTITUTIONS. THE CONTRACTOR SHALL REPLACE AT THE CONTRACTOR'S COST ANY PRODUCT UTILIZED THAT HAS NOT BEEN APPROVED IN WRITING BY THE PARKS AND COMMUNITY SERVICES PROJECT MANAGER.
- THE CONTRACTOR SHALL COORDINATE WITH AND NOTIFY THE PARKS AND COMMUNITY SERVICES PROJECT MANAGER OF THE REQUIRED PRE-CONSTRUCTION MEETINGS TO BE HELD ON SITE.
- THE CONTRACTOR OR DEVELOPER SHALL GUARANTEE ALL MATERIALS AND WORKMANSHIP FOR A PERIOD OF ONE (1) YEAR AFTER PARKS AND COMMUNITY SERVICES ACCEPTS THE SITE IMPROVEMENTS.
- THE CONTRACTOR OR DEVELOPER SHALL MAINTAIN ALL LANDSCAPING FOR A PERIOD OF ONE (1) YEAR AFTER THE PARKS AND COMMUNITY SERVICES HAS ACCEPTED ALL IMPROVEMENTS FOR MAINTENANCE WITHIN COMMUNITY SERVICES DISTRICTS. BONDS SHALL BE REQUIRED IN THE AMOUNT TO COVER THE WORK. CITY FUNDED PROJECTS ARE EXEMPT FROM THIS REQUIREMENT.

NOT TO SCALE

CITY OF MORENO VALLEY
PARKS AND COMMUNITY SERVICES DEPARTMENT
STANDARD PLAN
MVGF-600-0
SHEET 1 OF 1

SHEET INDEX

Sheet Description	Sheet Number	Sheet Title
LT-1	1	TITLE SHEET
LHL-1	2	AMENITIES, HARDSCAPE, AND CONSTRUCTION SCHEDULES & NOTES
LH-1	3	HARDSCAPE PLAN
LH-2	4	HARDSCAPE ENLARGEMENT PLAN
LH-3	5	PLAYGROUND ENLARGEMENT PLAN
LHD-1	6	HARDSCAPE DETAILS
LHD-2	7	HARDSCAPE DETAILS
LHD-3	8	HARDSCAPE DETAILS
LHD-4	9	HARDSCAPE DETAILS
LHD-5	10	HARDSCAPE DETAILS
LHD-6	11	HARDSCAPE DETAILS
LHD-7	12	HARDSCAPE DETAILS
LIL-1	13	IRRIGATION SCHEDULES & NOTES
LI-1	14	IRRIGATION PLAN
LID-1	15	IRRIGATION DETAILS
LID-2	16	IRRIGATION DETAILS
LID-3	17	IRRIGATION DETAILS
LID-4	18	IRRIGATION DETAILS
LID-5	19	IRRIGATION DETAILS
LPL-1	20	PLANTING SCHEDULES & NOTES
LP-1	21	PLANTING PLAN
LPD-1	22	PLANTING DETAILS
LPD-2	23	PLANTING DETAILS

ELECTRICAL		
Sheet Number	Sheet Description	Sheet Title
1	E-1.0	COVER SHEET
2	E-2.0	ELECTRICAL PLAN
3	E-3.0	ELECTRICAL NOTES AND DETAILS

NOTICE TO CONTRACTORS

THE EXISTENCE AND LOCATION OF ANY UNDERGROUND UTILITY PIPES OR STRUCTURES SHOWN ON THESE PLANS WERE OBTAINED BY A SEARCH OF AVAILABLE RECORDS. THESE LOCATIONS ARE APPROXIMATE AND SHALL BE CONFIRMED IN FIELD BY THE CONTRACTOR, SO THAT ANY NECESSARY ADJUSTMENT CAN BE MADE IN ALIGNMENT AND/OR GRADE OF THE PROPOSED IMPROVEMENT. THE CONTRACTOR IS REQUIRED TO TAKE DUE PRECAUTIONARY MEASURES TO PROTECT ANY UTILITY LINES SHOWN AND ANY OTHER LINES NOT OF RECORD OR NOT SHOWN ON THESE PLANS.

HOLD HARMLESS & INDEMNIFICATION CLAUSE

CONTRACTOR AGREES THAT THEY SHALL ASSUME SOLE RESPONSIBILITY FOR JOB SITE CONDITIONS DURING THE COURSE OF CONSTRUCTION OF THIS PROJECT, INCLUDING SAFETY OF ALL PERSONS AND PROPERTY, THAT THIS REQUIREMENT SHALL APPLY CONTINUOUSLY AND NOT BE LIMITED TO NORMAL WORKING HOURS, AND HOLD THE CITY AND THE LANDSCAPE ARCHITECT HARMLESS FROM ANY AND ALL LIABILITY REAL OR ALLEGED, IN CONNECTION WITH THE PERFORMANCE OF WORK ON THIS PROJECT, EXCEPTING FOR LIABILITY ARISING FROM THE SOLE NEGLIGENCE OF THE OWNER, OR THE LANDSCAPE ARCHITECT.

BUILDING AND SAFETY DIVISION

- LIGHTING
- POLYGON STRUCTURE
- MONUMENT SIGN
- PARK DEDICATION PLAQUE

CONSTRUCTION NOTES:

- The design shown is diagrammatic, the contractor shall review the site conditions prior to bidding.
- The contractor shall provide for positive drainage away from all structures at a 1% minimum for hardscape areas and a 2% minimum for landscaped areas unless otherwise directed by the civil engineering plans.
- The contractor must notify the Landscape Architect, (951) 737-1124, 48 hours prior to starting construction.
- The contractor must notify the City of Moreno Valley at (951) 413-3702, 48 hours prior to starting construction.
- The contractor shall be responsible for obtaining building & plumbing permits prior to commencing construction and is responsible for inspection schedules.
- The contractor shall notify the Landscape Architect if discrepancies exist between existing site conditions and plans.
- All landscape construction shall meet or exceed the local controlling jurisdiction's standards and guidelines.
- The contractor shall take great care to protect existing site amenities during the process of construction. Items not specifically identified for protection shall be protected in place.
- All concrete paving to be installed per these plans shall be 2500 psi P.C.C. @ 28 days unless otherwise noted.
- All steel connectors to be continuous welded. Remove all slag and spatter and grind all welds smooth. All tubing to have ends welded closed. Paint all steel with (1) coat zinc chromate primer and with (2) coats Rustoleum, color to be black unless otherwise noted. Contractor to provide shop drawings for approval by landscape architect.
- Do not scale from plans or details.
- Refer to manufacturer's recommendation for installation of all amenities
- These plans are diagrammatic, the contractor shall notify the landscape architect of conflicts between the plans and the site conditions.
- All radii corners at the intersection of two or more walls or paths shall be not less than 3' unless otherwise noted on plan or detail.
- All curb adjacent dimensions are taken from face of curb.

AFFECTED UTILITIES

BOX SPRINGS MUTUAL WATER COMPANY	(951) 853-5419
CHARTER SPECTRUM	(877) 905-9121
EASTERN MUNICIPAL WATER DISTRICT	(951) 926-3777
EDGEMONT COMMUNITY SERVICES DEPARTMENT	(951) 754-3522
FRONTIER COMMUNICATION	(800) 321-3101
S.C. EDISON COMPANY	(800) 655-4555
S.C. GAS COMPANY	(800) 427-2200
SUNESYS	(951) 275-0400
RIVERSIDE TRANSIT AGENCY	(951) 565-5154
UNDERGROUND SERVICE ALERT	(800) 227-2600
MORENO VALLEY UTILITY ADMINISTRATION	(951) 413-3600
SPECIAL DISTRICTS ADMINISTRATION	(951) 413-3400
TRAFFIC SIGNAL MAINTENANCE (CITY)	(951) 413-3140
VERIZON WIRELESS	(800) 323-0204

APPROVALS

DANIEL MONTO
PARKS AND LANDSCAPE SERVICES DIVISION MANAGER:

DATE: _____

JEREMY BUBNICK
PARKS AND COMMUNITY SERVICES DIRECTOR:

DATE: _____

<p>NO WORK SHALL BE DONE ON THIS SITE UNTIL BELOW AGENCY IS NOTIFIED OF INTENTION TO GRADE OR EXCAVATE.</p> <p>Underground Service Alert Call: TOLL FREE 811</p> <p>WWW.CALL811.COM TWO WORKING DAYS BEFORE YOU DIG</p>	<p>BASIS OF BEARING</p> <p>THE BASIS OF BEARINGS FOR THIS SURVEY IS THE CALIFORNIA STATE PLANE COORDINATE SYSTEM CCS83, ZONE 6, BASED LOCALLY ON CONTROL STATIONS "TR4", "TR47", AND "S80C" NAD 83 (NRSR2011) EPOCH 2010.00 AS SHOWN HEREON. ALL BEARINGS SHOWN ON THIS MAP ARE GRID. QUOTED BEARINGS AND DISTANCES FROM REFERENCE MAPS OR DEEDS ARE AS SHOWN PER THAT RECORD REFERENCE. ALL DISTANCES SHOWN ARE GROUND DISTANCES UNLESS SPECIFIED OTHERWISE. GRID DISTANCES MAY BE OBTAINED BY MULTIPLYING THE GROUND DISTANCE BY A COMBINATION FACTOR OF 0.99993579. CALCULATIONS ARE MADE AT TYPED TAGGED "LS 5174", DOWN 0.2" IN WELL PER TRACT 36882, MB 454-07-09 WITH COORDINATES OF N: 227736.255000000, E: 628631.210000000 USING AN ELEVATION OF 1665.533</p>	<p>REVIEW BY CITY STAFF</p> <table border="1"> <thead> <tr><th>OFFICE</th><th>INITIAL</th><th>DATE</th><th>NO.</th><th>DATE</th><th>INITIALS</th><th>DATE</th><th>APPR</th></tr> </thead> <tbody> <tr><td>ENGINEERING DIVISION MANAGER</td><td></td><td></td><td></td><td></td><td></td><td></td><td></td></tr> <tr><td>LAND DEVELOPMENT</td><td></td><td></td><td></td><td></td><td></td><td></td><td></td></tr> <tr><td>PLANNING</td><td></td><td></td><td></td><td></td><td></td><td></td><td></td></tr> <tr><td>TRANSPORTATION</td><td></td><td></td><td></td><td></td><td></td><td></td><td></td></tr> <tr><td>PARKS AND COMMUNITY SERVICES</td><td></td><td></td><td></td><td></td><td></td><td></td><td></td></tr> <tr><td>SPECIAL DISTRICTS</td><td></td><td></td><td></td><td></td><td></td><td></td><td></td></tr> <tr><td>STORM WATER MANAGEMENT PROGRAM</td><td></td><td></td><td></td><td></td><td></td><td></td><td></td></tr> </tbody> </table>	OFFICE	INITIAL	DATE	NO.	DATE	INITIALS	DATE	APPR	ENGINEERING DIVISION MANAGER								LAND DEVELOPMENT								PLANNING								TRANSPORTATION								PARKS AND COMMUNITY SERVICES								SPECIAL DISTRICTS								STORM WATER MANAGEMENT PROGRAM								<p>E.O.R.</p> <p>REVISION</p> <table border="1"> <thead> <tr><th>DESCRIPTION</th><th>DATE</th><th>APPR</th></tr> </thead> <tbody> <tr><td> </td><td> </td><td> </td></tr> <tr><td> </td><td> </td><td> </td></tr> <tr><td> </td><td> </td><td> </td></tr> </tbody> </table>	DESCRIPTION	DATE	APPR										<p>LANDSCAPE ARCHITECT OF RECORD'S SEAL</p> <p>PLANS PREPARED UNDER THE SUPERVISION OF:</p> <p><i>Shannon P. Karlson</i> SIGNATURE 10/31/23 EXP. DATE 8/21/23 DATE</p> <p>SHANNON P. KARLSON R.L.A. #6070 (EXP. 10/31/23)</p>	<p>CITY OF MORENO VALLEY</p> <p>PUBLIC PARK IMPROVEMENT PLANS TRACT 38236 STELLA POINTE & BELLA SERA</p> <p>LT-1</p> <p>SHEET 1 OF 23</p> <p>CITY ID No: ---</p>
	OFFICE	INITIAL	DATE	NO.	DATE	INITIALS	DATE	APPR																																																																									
ENGINEERING DIVISION MANAGER																																																																																	
LAND DEVELOPMENT																																																																																	
PLANNING																																																																																	
TRANSPORTATION																																																																																	
PARKS AND COMMUNITY SERVICES																																																																																	
SPECIAL DISTRICTS																																																																																	
STORM WATER MANAGEMENT PROGRAM																																																																																	
DESCRIPTION	DATE	APPR																																																																															
<p>CITY OF MORENO VALLEY</p> <p>PUBLIC PARK IMPROVEMENT PLANS TRACT 38236 STELLA POINTE & BELLA SERA</p> <p>TITLE SHEET</p>					<p>8/21/23 DATE</p>																																																																												

HARDSCAPE NOTES:

- ALL CONCRETE CONSTRUCTION SHALL BE 2,500 PSI AT 28 DAYS CONCRETE, UNLESS OTHERWISE DIRECTED BY SOILS REPORT OR AGENCY.
- ALL PAVING SHALL BE SLOPED TO DRAIN AT A MIN. 1% AWAY FROM STRUCTURES. THE LANDSCAPE AREAS SHALL BE SLOPED AT 2% AWAY FROM STRUCTURES. REFER TO CIVIL GRADING PLANS FOR ADDITIONAL INFORMATION
- THE CONTRACTOR IS RESPONSIBLE FOR ALL PERMITS AND INSPECTION SCHEDULES
- THE PLANS ARE DIAGRAMMATIC, THE CONTRACTOR SHALL NOTIFY THE LANDSCAPE ARCHITECT OF CONFLICTS BETWEEN THE PLANS AND THE SITE CONDITIONS
- INSTALL ALL AMENITIES AND FENCING MATERIAL PER MANUFACTURER INSTRUCTIONS AND SPECIFICATIONS

AMENITIES NOTES:

- CONTACT ALL MANUFACTURERS PER LEGEND AND DISTRIBUTOR LIST WHEN ORDERING ITEMS/EQUIPMENT FOR EXACT LEAD TIME.

DISTRIBUTORS LIST		
MANUFACTURER	DISTRIBUTOR	CONTACT INFO
CALIFORNIA SPORTS SURFACES	CALIFORNIA SPORTS SURFACES	(978) 623-9980
FIBAR	FIBAR	(800) 342-2721 80 BUSINESS PARK DRIVE ARMONK, NY 10504
LA STEELCRAFT	LA STEELCRAFT	(800) 687-5768 140 GILBERT MESA, AZ 85203
POLIGON	MIRACLE	BRYCE LAWRENCE (800) 264-7225 X 102 9106 PULSAR CT CORONA, CA 92883
MOST DEPENDABLE FOUNTAINS	MOST DEPENDABLE FOUNTAINS	(901) 867-0039
PILOT ROCK	PILOT ROCK	(800) 762-5002
OUTDOOR CREATIONS	OUTDOOR CREATIONS	(530) 338-8367 2270 BARNEY RD ANDERSON, CA 96007
MADRAX	MADRAX	(800) 448-7931
KOMPAN	KOMPAN	PAUL DANIELS (657) 298-7086
MIRACLE	MIRACLE	BRYCE LAWRENCE (800) 264-7225 X 102 9106 PULSAR CT CORONA, CA 92883
ZERO WASTE USA	ZERO WASTE USA	(800) 789-2563 12316 WORLD TRADE DR STE 102 SAN DIEGO, CA 92128
AMERISTAR	AMERISTAR	(888) 333-3422
SPECTRA TURF	SPECTRA TURF	(800) 875-5788 555 SOUTH PROMENADE AVENUE SUITE 103 CORONA, CA 92879

CONSTRUCTION SCHEDULE

SYMBOL	DESCRIPTION	QTY	DETAIL	MATERIAL	COLOR/FINISH	REMARKS	MANUFACTURER
C-01	6" MOWCURB	275 LF	7/LPD-1	CONCRETE	NATURAL GRAY/MEDIUM BROOM FINISH	PER CITY STANDARD DETAIL	
C-02	8" MOWCURB	140 LF	8/LPD-1	CONCRETE	NATURAL GRAY/MEDIUM BROOM FINISH	PER CITY STANDARD DETAIL. LOCATED BENEATH TUBULAR STEEL FENCES ONLY.	
C-03	PLAYGROUND CURB	412 LF	4/LHD-3	CONCRETE	NATURAL GRAY/MEDIUM BROOM FINISH		
C-04	SURFACING EDGE CONDITION AROUND PAVING		2/LHD-3				
C-05	ADA RAMP AT TOT LOT	2	3/LHD-3	CONCRETE	NATURAL GRAY	REFERENCE CIVIL PLANS FOR DRAINAGE	
C-06	PARK MONUMENT SIGN	1	3 & 4/LHD-1			NAME TBD BY CITY	OUTDOOR CREATIONS
C-07	PARK DEDICATION PLAQUE	1	3 & 4/LHD-2				
C-08	4'-0" TALL PERIMETER FENCE	140 LF	1 & 2/LHD-2	TUBULAR STEEL	BLACK		AMERISTAR - AEGIS II, MAJESTIC 3-RAIL
C-09	12" WIDE STEPOUT AT PARKING		1/LHD-3	CONCRETE	NATURAL GRAY/MEDIUM BROOM	TOOLED JOINTS @ 6' O.C. AND ALL DIRECTION CHANGES. REFERENCE CIVIL PLANS.	
C-10	WALLS / PILASTERS BY CIVIL		-	REFER TO CIVIL ENGINEER'S PLANS		ALL WALLS AND PILASTERS TO RECEIVE VITROCEM ANTI-GRAFFITI COATING	BLOCK WALL NOT A PART OF THIS BID. CONTRACTOR TO BID ADDING GRAFFITI COATING TO PARK FACING WALL.

HARDSCAPE SURFACING SCHEDULE

SYMBOL	DESCRIPTION	QTY	DETAIL	COLOR	FINISH	REMARKS	MANUFACTURER
H-01	4" THICK CONCRETE W/REBAR PER DETAIL	14,487 SF	5/LHD-1	NATURAL GRAY	MEDIUM BROOM	HAND TROWELED SCORELINES	
H-02	4" THICK CONCRETE W/REBAR PER DETAIL	1,716 SF	5/LHD-1	NATURAL GRAY	TOP CAST #05 (SANDBLAST FINISH)	SAWCUT SCORELINES	
H-03	EXERCISE RUBBERIZED SURFACING	602 SF	2/LHD-3	40% STANDARD GREEN, 40% BROWN, 20% BEIGE	-	ALIPHATIC BINDER FOR WEAR COURSE	SPECTRA TURF OR APPROVED EQUAL
H-04	12" DEPTH PLAYGROUND FIBAR CHIPS	4,931 SF	4/LHD-3		FIBARSYSTEM 100	PER DETAIL	FIBAR
H-05	6" THICK CONCRETE WITH PLEXIPAVE SURFACING	683 SF	SHEET LHD-7	CALIFORNIA RED		6" THICK BB COURT CONCRETE WITH REBAR	AVAILABLE FROM CALIFORNIA SPORT SURFACE
H-06	6" THICK CONCRETE WITH PLEXIPAVE SURFACING	2,446 SF	SHEET LHD-7	DARK GREEN		6" THICK BB COURT CONCRETE WITH REBAR	AVAILABLE FROM CALIFORNIA SPORT SURFACE
H-07	6" THICK CONCRETE WITH PLEXIPAVE SURFACING	1,071 SF	SHEET LHD-7	SAHARA SAND		6" THICK BB COURT CONCRETE WITH REBAR	AVAILABLE FROM CALIFORNIA SPORT SURFACE

AMENITIES SCHEDULE

SYMBOL	DESCRIPTION	DETAIL	MODEL #	MANUFACTURER	COLOR	REMARKS	QTY.
A-01	SHADE STRUCTURE	SHEET LHD-5	RAM-24X34SS	POLIGON	ROOF COLOR: EVERGREEN, FRAME COLOR: SURREY BEIGE	CONTRACTOR TO SUBMIT STRUCTURAL DRAWINGS FROM MANUFACTURER FOR BUILDING DEPARTMENT APPROVAL. DEFERRED SUBMITTAL.	1
A-02	BENCH	1/LHD-4	402SK	OUTDOOR CREATIONS	MEDIUM GRAY		3
A-03	PICNIC TABLE	2/LHD-4	100FSSK	OUTDOOR CREATIONS	MEDIUM GRAY		8
A-04	PICNIC TABLE - ADA	3/LHD-4	100FSSK2E	OUTDOOR CREATIONS	MEDIUM GRAY		2
A-05	WASTE RECEPTACLE	4/LHD-4	510	OUTDOOR CREATIONS	MEDIUM GRAY		10
A-06	DRINKING FOUNTAIN W/ BOTTLE FILLER AND PET FOUNTAIN	1 & 2/LHD-1 8/LHD-4	10150 SMSS PF	MOST DEPENDABLE FOUNTAINS	GREEN	SS=STAINLESS STEEL (POWDER COATED) PF=PET FOUNTAIN	3
A-07	PET STATION	5/LHD-4	JJB006-BLK	ZERO WASTE USA	GREEN		2
A-08	BBQ GRILL	6/LHD-4	N-20 S3 B2	PILOT ROCK	BLACK	IN-GROUND MOUNT, WITH BOLT-ON SHELF	1
A-09	HOT COAL RECEPTACLE	5/LHD-3	300CR	OUTDOOR CREATIONS	MEDIUM GRAY		1
A-10	BIKE RACK	7/LHD-4	CS200-7	MADRAX	LEXINGTON GREEN		1
A-11	TRIPLE BARS	SHEET LHD-6	FSW210	KOMPAN	PER QUOTE # SP122350-1	EQUIPMENT COLORS TO BE MOSS GREEN	1
A-12	PULL UP STATION	SHEET LHD-6	FSW208	KOMPAN	PER QUOTE # SP122350-1	EQUIPMENT COLORS TO BE MOSS GREEN	1
A-13	SIT UP BENCH	SHEET LHD-6	FSW203	KOMPAN	PER QUOTE # SP122350-1	EQUIPMENT COLORS TO BE MOSS GREEN	1
A-14	SUSPENSION TRAINER, CORE TWIST, MAGNETIC BELLS LINK	SHEET LHD-6	FAZ20401	KOMPAN	PER QUOTE # SP122350-1	EQUIPMENT COLORS TO BE MOSS GREEN	1
A-15	PULL UP BARS	SHEET LHD-6	FAZ103	KOMPAN	PER QUOTE # SP122350-1	EQUIPMENT COLORS TO BE MOSS GREEN	1
A-16	PLAY STRUCTURES AGES 2-5	SHEET LH-3	MREC 2-5	MIRACLE	PER QUOTE # MREC 3090	DRAWING NO. R0036_44816295695. EQUIPMENT COLORS TO MATCH QUOTE RENDERINGS	1
A-17	PLAY STRUCTURES AGES 5-12	SHEET LH-3	MREC 5-12	MIRACLE	PER QUOTE # MREC 3090	DRAWING NO. R0036_44816295695. EQUIPMENT COLORS TO MATCH QUOTE RENDERINGS	1
A-18	PARK LIGHTING	8/LHD-1				REFER TO ELECTRICAL PLANS. PARK LIGHTING WITHIN TURF TO HAVE A CONCRETE COLLAR PER CITY STANDARD DETAIL - CONCRETE COLLAR SHAPE WILL VARY. REFER TO CITY STANDARD DETAIL MVGF-626-0 FOR REQUIRED DIMENSIONS.	-
A-19	PARK RULES SIGN	6 & 7/LHD-1				MOUNTED TO POST PER CITY STANDARD DETAIL WITH INFORMATION TO BE PROVIDED BY CITY	4
A-20	BACK-TO-BACK GOOSENECK BASKETBALL POSTS, BACKBOARD, NET, RIM & POST PAD	SHEET LHD-7	LA-12C066-CURVED POST/DOUBLE W/ 6" EXTENSION LA-04-HEAVY DUTY FIBERGLASS BACKBOARD LA-34-SUPER NYLON NET LA-45-HEAVY DUTY DOUBLE RIM LA-PP-666-POST PAD	L.A. STEELCRAFT	POSTS-GALVANIZED STEEL BOARDS-WHITE W/ ORANGE TARGET & PERIMETER POST PAD-GREEN	REFER TO DETAILS	1

<p>NO WORK SHALL BE DONE ON THIS SITE UNTIL BELOW AGENCY IS NOTIFIED OF INTENTION TO GRADE OR EXCAVATE.</p> <p>Underground Service Alert Call: TOLL FREE 811</p> <p>WWW.CALL811.COM TWO WORKING DAYS BEFORE YOU DIG</p>	<p>BASIS OF BEARING</p> <p>THE BASIS OF BEARINGS FOR THIS SURVEY IS THE CALIFORNIA STATE PLANE COORDINATE SYSTEM CCS83, ZONE 6, BASED LOCALLY ON CONTROL STATIONS "TR40", "TR47", AND "SBOC" NAD 83 (NRSR2011) EPOCH 2010.00 AS SHOWN HEREON. ALL BEARINGS SHOWN ON THIS MAP ARE GRID. QUOTED BEARINGS AND DISTANCES FROM REFERENCE MAPS OR DEEDS ARE AS SHOWN PER THAT RECORD REFERENCE. ALL DISTANCES SHOWN ARE GROUND DISTANCES UNLESS SPECIFIED OTHERWISE. GRID DISTANCES MAY BE OBTAINED BY MULTIPLYING THE GROUND DISTANCE BY A COMBINATION FACTOR OF 0.99999579. CALCULATIONS ARE MADE AT TYP. TAGGED "LS 5174", DOWN 0.2' IN WELL PER TRACT 36882, MB 454/07-09 WITH COORDINATES OF: N: 227736.255000000, E: 6286431.21000000 USING AN ELEVATION OF 1665.533</p>	<p>REVIEW BY CITY STAFF</p> <table border="1"> <tr> <th>OFFICE</th> <th>INITIAL</th> <th>DATE</th> </tr> <tr> <td>ENGINEERING DIVISION MANAGER</td> <td></td> <td></td> </tr> <tr> <td>LAND DEVELOPMENT</td> <td></td> <td></td> </tr> <tr> <td>PLANNING</td> <td></td> <td></td> </tr> <tr> <td>TRANSPORTATION</td> <td></td> <td></td> </tr> <tr> <td>PARKS AND COMMUNITY SERVICES</td> <td></td> <td></td> </tr> <tr> <td>SPECIAL DISTRICTS</td> <td></td> <td></td> </tr> <tr> <td>STORM WATER MANAGEMENT PROGRAM</td> <td></td> <td></td> </tr> </table>		OFFICE	INITIAL	DATE	ENGINEERING DIVISION MANAGER			LAND DEVELOPMENT			PLANNING			TRANSPORTATION			PARKS AND COMMUNITY SERVICES			SPECIAL DISTRICTS			STORM WATER MANAGEMENT PROGRAM			<p>E.O.R.</p> <table border="1"> <tr> <th>NO.</th> <th>DATE</th> <th>INITIALS</th> </tr> <tr> <td></td> <td></td> <td></td> </tr> </table>	NO.	DATE	INITIALS				<p>REVISION</p> <table border="1"> <tr> <th>DESCRIPTION</th> <th>DATE</th> <th>APPR</th> </tr> <tr> <td></td> <td></td> <td></td> </tr> </table>	DESCRIPTION	DATE	APPR				<p>LANDSCAPE ARCHITECT OF RECORD'S SEAL</p>	<p>bmla LANDSCAPE ARCHITECTURE</p> <p>310 NORTH JOY STREET CORONA, CA 92670 TEL: 951.267.1124 FAX: 951.267.6667</p> <p>PLANS PREPARED UNDER THE SUPERVISION OF:</p> <p><i>Shannon P. Karlson</i> SHANNON P. KARLSON R.L.A. #6070 (EXP. 10/31/23)</p> <p>8/21/23 DATE</p>	<p>CITY OF MORENO VALLEY</p> <p>PUBLIC PARK IMPROVEMENT PLANS TRACT 38236 STELLA POINTE & BELLA SERA</p> <p>LHL-1</p> <p>SHEET 2 OF 23</p> <p>CITY ID No. ---</p>
		OFFICE	INITIAL	DATE																																								
ENGINEERING DIVISION MANAGER																																												
LAND DEVELOPMENT																																												
PLANNING																																												
TRANSPORTATION																																												
PARKS AND COMMUNITY SERVICES																																												
SPECIAL DISTRICTS																																												
STORM WATER MANAGEMENT PROGRAM																																												
NO.	DATE	INITIALS																																										
DESCRIPTION	DATE	APPR																																										
<p>AMENITIES, HARDSCAPE, AND CONSTRUCTION SCHEDULES & NOTES</p>																																												

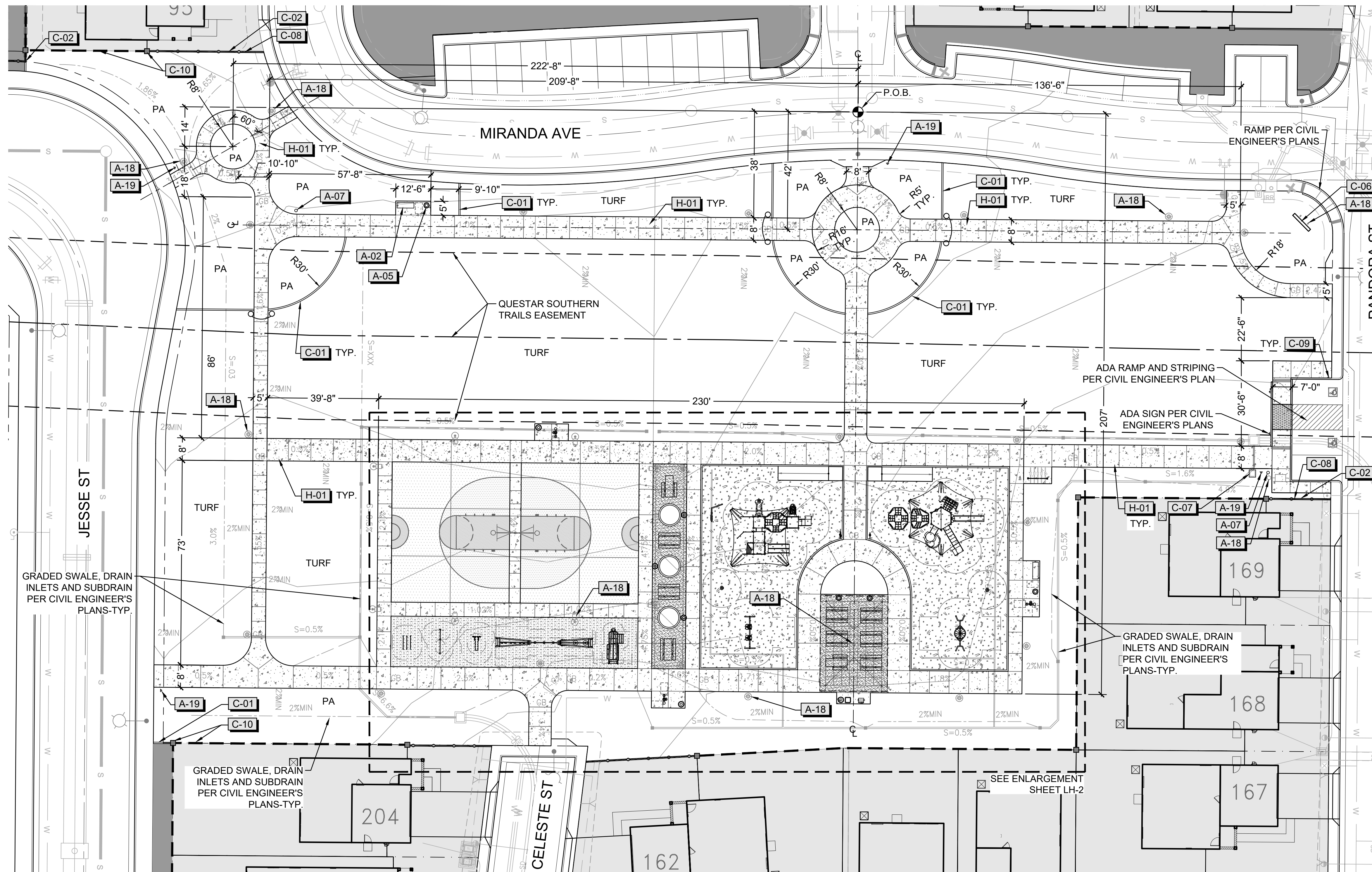

NOTE:
PARKING LOT AND DIMENSIONS FOR PARKING LOT PER CIVIL ENGINEER'S PLANS

- N.A.P.
REFER TO TFY & REAR YARD SLOPE PLANS
PREPARED BY BMLA
- N.A.P.
REFER TO HOA PLANS PREPARED BY BMLA

REFER TO SHEET LHL-1 FOR COMPLETE AMENITIES, CONSTRUCTION, & HARDSCAPE SCHEDULES

- HARDSCAPE LAYOUT & DIMENSIONS NOTES:
1. CONTRACTOR TO REFERENCE CIVIL ENGINEER'S PLAN FOR FINAL SPOT ELEVATIONS FOR ALL CONCRETE WORK.
 2. DIMENSIONS ON THIS PLAN ARE FOR REFERENCE ONLY. CONTRACTOR TO REFERENCE CIVIL ENGINEER'S FINAL GRADING PLAN FOR FINAL LAYOUT.

INDEX MAP NTS

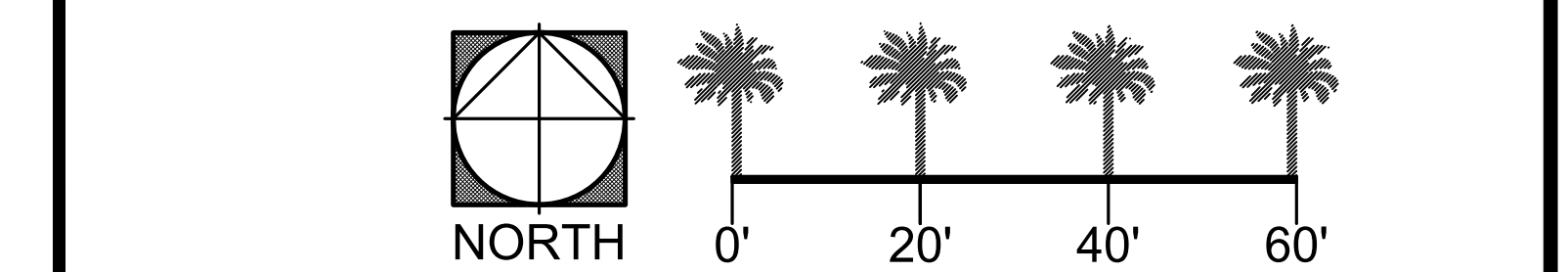
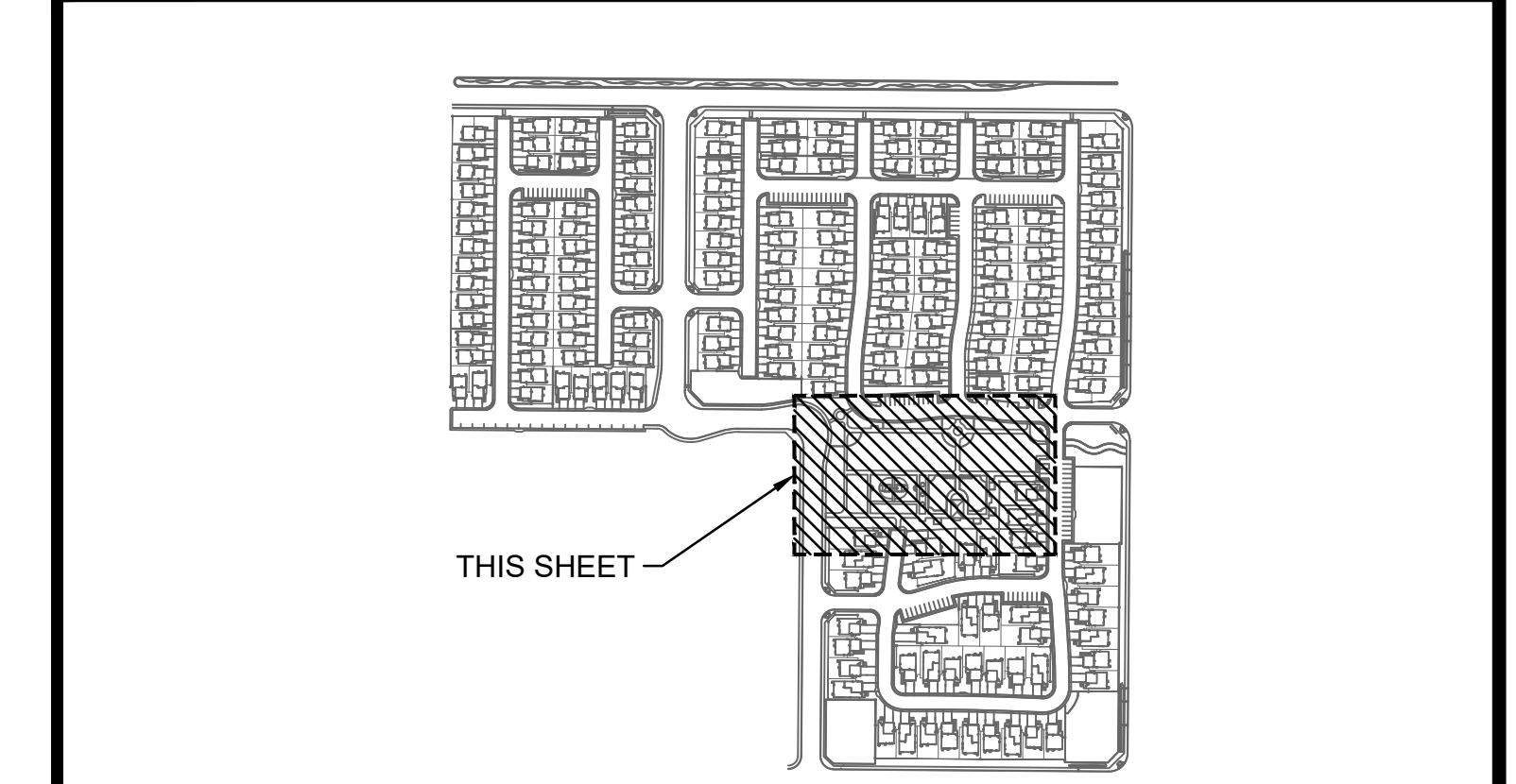

NO WORK SHALL BE DONE ON THIS SITE UNTIL BELOW AGENCY IS NOTIFIED OF INTENTION TO GRADE OR EXCAVATE.
Underground Service Alert
Call: TOLL FREE 811
WWW.CALL811.COM
TWO WORKING DAYS BEFORE YOU DIG

BASIS OF BEARING
THE BASIS OF BEARINGS FOR THIS SURVEY IS THE CALIFORNIA STATE PLANE COORDINATE SYSTEM CCS83, ZONE 6, BASED LOCALLY ON CONTROL STATIONS "TR40", "TR47", AND "TR50" NAD 83 (NAD 83) EPOCH 2010.00 AS SHOWN HEREON. ALL BEARINGS SHOWN ON THIS MAP ARE GRID. QUOTED BEARINGS AND DISTANCES FROM REFERENCE MAPS OR DEEDS ARE AS SHOWN PER THAT RECORD REFERENCE. ALL DISTANCES SHOWN ARE GROUND DISTANCES UNLESS SPECIFIED OTHERWISE. GRID DISTANCES MAY BE OBTAINED BY MULTIPLYING THE GROUND DISTANCE BY A COMBINATION FACTOR OF 0.999993579. CALCULATIONS ARE MADE AT TYP TAGGED "LS 5174", DOWN 0.2" IN WELL PER TRACT 36882, MB 454-07--39 WITH COORDINATES OF: N: 22736.255000000, E: 6280431.21000000 USING AN ELEVATION OF 1665.533

REVIEW BY CITY STAFF		E.O.R.		REVISION					
OFFICE	ENGINEERING DIVISION MANAGER	INITIAL	DATE	NO.	DATE	INITIALS	DESCRIPTION	DATE	APPR
LAND DEVELOPMENT									
PLANNING									
TRANSPORTATION									
PARKS AND COMMUNITY SERVICES									
SPECIAL DISTRICTS									
STORM WATER MANAGEMENT PROGRAM									

LANDSCAPE ARCHITECT OF RECORD'S SEAL
REGISTERED LANDSCAPE ARCHITECT
SHANNON P. KARLSON
R.L.A. #6070 (EXP. 10/31/23)
DATE 8/21/23

bmla
LANDSCAPE ARCHITECTURE
310 NORTH JOY STREET | CORONA, CA 92626
TEL: 951.267.1294 | FAX: 951.267.6691
PLANS PREPARED UNDER THE SUPERVISION OF:
SHANNON P. KARLSON
R.L.A. #6070 (EXP. 10/31/23)
DATE 8/21/23

CITY OF MORENO VALLEY
PUBLIC PARK IMPROVEMENT PLANS
TRACT 38236
STELLA PONTE & BELLA SERA
HARDSCAPE PLAN
LH-1
SHEET 3 OF 23
CITY ID No. ---

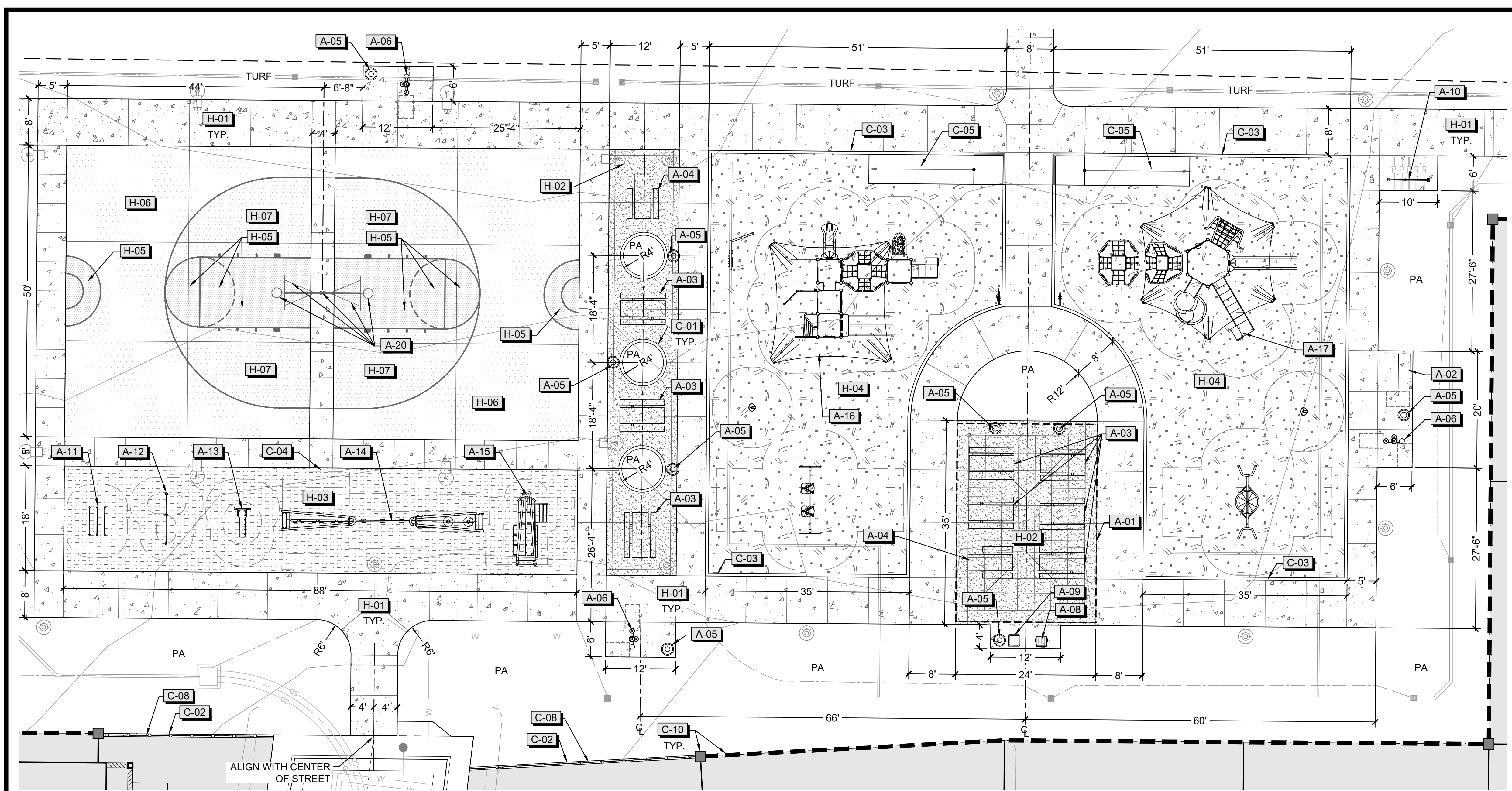

N.A.P.
REFER TO TFY & REAR YARD SLOPE PLANS
PREPARED BY BMLA

REFER TO SHEET LHL-1 FOR COMPLETE AMENITIES, CONSTRUCTION, &
HARDSCAPE SCHEDULES

HARDSCAPE LAYOUT & DIMENSIONS NOTES:
1. CONTRACTOR TO REFERENCE CIVIL ENGINEER'S PLAN FOR FINAL SPOT
ELEVATIONS FOR ALL CONCRETE WORK.
2. DIMENSIONS ON THIS PLAN ARE FOR REFERENCE ONLY. CONTRACTOR TO
REFER TO CIVIL ENGINEER'S FINAL GRADING PLAN FOR FINAL LAYOUT.

INDEX MAP NTS

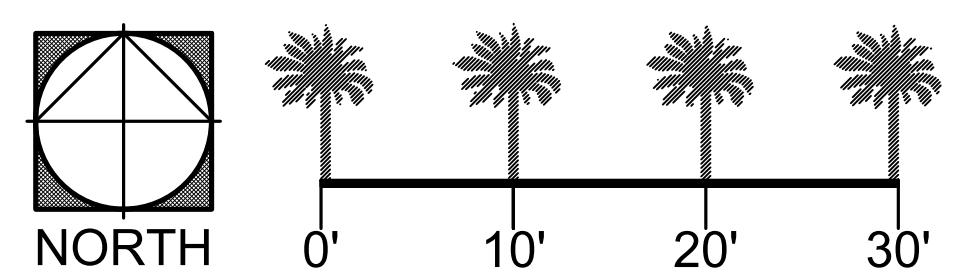
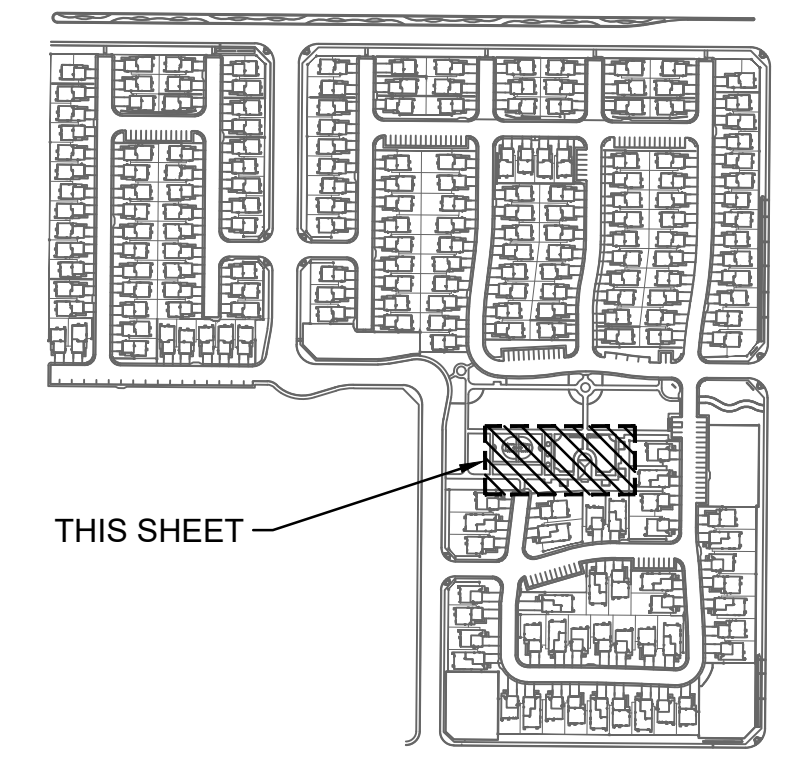

NO WORK SHALL BE DONE ON THIS
SITE UNTIL BELOW AGENCY IS NOTIFIED
OF INTENTION TO GRADE OR EXCAVATE.
Underground Service Alert
Call: TOLL FREE
811
WWW.CALL811.COM
TWO WORKING DAYS BEFORE YOU DIG

BASIS OF BEARING
THE BASIS OF BEARINGS FOR THIS SURVEY IS THE
CALIFORNIA STATE PLANE COORDINATE SYSTEM
CCS83, ZONE 6, BASED LOCALLY ON CONTROL
STATIONS "TR48", "TR47", AND "SBCO" NAD 83
(NRSR2011) EPOCH 2010.00 AS SHOWN HEREON.
ALL BEARINGS SHOWN ON THIS MAP ARE GRID.
QUOTED BEARINGS AND DISTANCES FROM
REFERENCE MAPS OR DEEDS ARE, AS SHOWN PER
THAT RECORD REFERENCE. ALL DISTANCES SHOWN
ARE GROUND DISTANCES UNLESS SPECIFIED
OTHERWISE. GRID DISTANCES MAY BE OBTAINED BY
MULTIPLYING THE GROUND DISTANCE BY A
COMBINATION FACTOR OF 0.999993579.
CALCULATIONS ARE MADE AT TYP TAGGED "LS
5174", DOWN 0.2" IN WELL PER TRACT 36882, MB
454/07-09 WITH COORDINATES OF:
N: 22736.255000000, E: 628631.21000000
USING AN ELEVATION OF 1665.533

REVIEW BY CITY STAFF		E.O.R.		REVISION					
OFFICE	ENGINEERING DIVISION MANAGER	INITIAL	DATE	NO.	DATE	INITIALS	DESCRIPTION	DATE	APPR
LAND DEVELOPMENT									
PLANNING									
TRANSPORTATION									
PARKS AND COMMUNITY SERVICES									
SPECIAL DISTRICTS									
STORM WATER MANAGEMENT PROGRAM									

LANDSCAPE ARCHITECT
OF RECORD'S SEAL

bmla
LANDSCAPE
ARCHITECTURE
310 NORTH JOY STREET | LOS ANGELES, CA 90007
TEL: 951.267.1124 | FAX: 951.267.6691
PLANS PREPARED UNDER THE SUPERVISION OF:

SHANNON P. KARLSON
R.L.A. #6070 (EXP. 10/31/23)
8/21/23
DATE

CITY OF MORENO VALLEY
PUBLIC PARK IMPROVEMENT PLANS
TRACT 38236
STELLA POINTE & BELLA SERA
HARDSCAPE ENLARGEMENT PLAN
LH-2
SHEET 4 OF 23
CITY ID No

Tract 38236
Moreno Valley, CA

AGE GROUP: 2-5
ELEVATED PLAY ACTIVITIES - TOTAL: 10
ELEVATED PLAY ACTIVITIES ACCESSIBLE BY TRANSFER: 7 RECD: 5
ELEVATED PLAY ACTIVITIES ACCESSIBLE BY RAMP: 4 RECD: 5
GROUND LEVEL ACTIVITY TYPE: 4 RECD: 2
GROUND LEVEL QUANTITY: 7 RECD: 3

AGE GROUP: 5-12
ELEVATED PLAY ACTIVITIES - TOTAL: 5
ELEVATED PLAY ACTIVITIES ACCESSIBLE BY TRANSFER: 5 RECD: 1
ELEVATED PLAY ACTIVITIES ACCESSIBLE BY RAMP: 0 RECD: 0
GROUND LEVEL ACTIVITY TYPE: 4 RECD: 2
GROUND LEVEL QUANTITY: 4 RECD: 2

Miracle

MIRACLE PLAYGROUND SALES, INC. R0036 44869638786
9106 Pulbari Ct. Corona, CA
PHONE NO: (800) 264-7225 x102
FAX NO: (877) 215-3869
COMPLIES TO ASTM/CPSC

GROUND SPACE: 59' 4" x 60' 0"
PROTECTIVE AREA: 108' 4" x 68' 0"
DRAWN BY: Bryce Lawrence DATE: 11/7/2022
COMPLIES TO ADA

To promote safe and proper equipment use by children, Miracle recommends the installation of either a Miracle safety sign or other appropriate safety signage near each playstation's main entry point(s) to inform parents and supervisors of the age appropriateness of the playstation and general rules for safe play.

THE PLAY COMPONENTS IDENTIFIED IN THIS PLAN ARE IPEMA CERTIFIED. THE USE AND LAYOUT OF THESE COMPONENTS CONFORM TO THE REQUIREMENTS OF ASTM F1487.

AN ENERGY ABSORBING PROTECTIVE SURFACE IS REQUIRED UNDER & AROUND ALL PLAY SYSTEMS.

Tract 38236
Moreno Valley, CA

AGE GROUP: 2-5
ELEVATED PLAY ACTIVITIES - TOTAL: 10
ELEVATED PLAY ACTIVITIES ACCESSIBLE BY TRANSFER: 7 RECD: 5
ELEVATED PLAY ACTIVITIES ACCESSIBLE BY RAMP: 4 RECD: 5
GROUND LEVEL ACTIVITY TYPE: 4 RECD: 2
GROUND LEVEL QUANTITY: 7 RECD: 3

AGE GROUP: 5-12
ELEVATED PLAY ACTIVITIES - TOTAL: 5
ELEVATED PLAY ACTIVITIES ACCESSIBLE BY TRANSFER: 5 RECD: 1
ELEVATED PLAY ACTIVITIES ACCESSIBLE BY RAMP: 0 RECD: 0
GROUND LEVEL ACTIVITY TYPE: 4 RECD: 2
GROUND LEVEL QUANTITY: 4 RECD: 2

Miracle

MIRACLE PLAYGROUND SALES, INC. R0036 44869638786
9106 Pulbari Ct. Corona, CA
PHONE NO: (800) 264-7225 x102
FAX NO: (877) 215-3869
COMPLIES TO ASTM/CPSC

GROUND SPACE: 59' 4" x 60' 0"
PROTECTIVE AREA: 108' 4" x 68' 0"
DRAWN BY: Bryce Lawrence DATE: 11/7/2022
COMPLIES TO ADA

To promote safe and proper equipment use by children, Miracle recommends the installation of either a Miracle safety sign or other appropriate safety signage near each playstation's main entry point(s) to inform parents and supervisors of the age appropriateness of the playstation and general rules for safe play.

THE PLAY COMPONENTS IDENTIFIED IN THIS PLAN ARE IPEMA CERTIFIED. THE USE AND LAYOUT OF THESE COMPONENTS CONFORM TO THE REQUIREMENTS OF ASTM F1487.

AN ENERGY ABSORBING PROTECTIVE SURFACE IS REQUIRED UNDER & AROUND ALL PLAY SYSTEMS.

Tract 38236
Moreno Valley, CA

AGE GROUP: 2-5
ELEVATED PLAY ACTIVITIES - TOTAL: 10
ELEVATED PLAY ACTIVITIES ACCESSIBLE BY TRANSFER: 7 RECD: 5
ELEVATED PLAY ACTIVITIES ACCESSIBLE BY RAMP: 4 RECD: 5
GROUND LEVEL ACTIVITY TYPE: 4 RECD: 2
GROUND LEVEL QUANTITY: 7 RECD: 3

AGE GROUP: 5-12
ELEVATED PLAY ACTIVITIES - TOTAL: 5
ELEVATED PLAY ACTIVITIES ACCESSIBLE BY TRANSFER: 5 RECD: 1
ELEVATED PLAY ACTIVITIES ACCESSIBLE BY RAMP: 0 RECD: 0
GROUND LEVEL ACTIVITY TYPE: 4 RECD: 2
GROUND LEVEL QUANTITY: 4 RECD: 2

Miracle

MIRACLE PLAYGROUND SALES, INC. R0036 44869638786
9106 Pulbari Ct. Corona, CA
PHONE NO: (800) 264-7225 x102
FAX NO: (877) 215-3869
COMPLIES TO ASTM/CPSC

GROUND SPACE: 59' 4" x 60' 0"
PROTECTIVE AREA: 108' 4" x 68' 0"
DRAWN BY: Bryce Lawrence DATE: 11/7/2022
COMPLIES TO ADA

To promote safe and proper equipment use by children, Miracle recommends the installation of either a Miracle safety sign or other appropriate safety signage near each playstation's main entry point(s) to inform parents and supervisors of the age appropriateness of the playstation and general rules for safe play.

THE PLAY COMPONENTS IDENTIFIED IN THIS PLAN ARE IPEMA CERTIFIED. THE USE AND LAYOUT OF THESE COMPONENTS CONFORM TO THE REQUIREMENTS OF ASTM F1487.

AN ENERGY ABSORBING PROTECTIVE SURFACE IS REQUIRED UNDER & AROUND ALL PLAY SYSTEMS.



NO WORK SHALL BE DONE ON THIS SITE UNTIL BELOW AGENCY IS NOTIFIED OF INTENTION TO GRADE OR EXCAVATE.

Underground Service Alert
Call: TOLL FREE 811
WWW.CALL811.COM
TWO WORKING DAYS BEFORE YOU DIG

BASIS OF BEARING

THE BASIS OF BEARINGS FOR THIS SURVEY IS THE CALIFORNIA STATE PLANE COORDINATE SYSTEM CCS83, ZONE 6, BASED LOCALLY ON CONTROL STATIONS "TR45", "TR47", AND "SR03" NAD 83 (NRSR2011) EPOCH 2010.00 AS SHOWN HEREON. ALL BEARINGS SHOWN ON THIS MAP ARE GRID. QUOTED BEARINGS AND DISTANCES FROM REFERENCE MAPS OR DEEDS ARE, AS SHOWN PER THAT RECORD REFERENCE. ALL DISTANCES SHOWN ARE GROUND DISTANCES UNLESS SPECIFIED OTHERWISE. GRID DISTANCES MAY BE OBTAINED BY MULTIPLYING THE GROUND DISTANCE BY A COMBINATION FACTOR OF 0.99999579. CALCULATIONS ARE MADE AT TYP TAGGED "LS 5174", DOWN 0.2' IN WELL PER TRACT 36882, MB 454-07--39 WITH COORDINATES OF: N: 22736.255000000, E: 6280631.21000000 USING AN ELEVATION OF 1665.533

REVIEW BY CITY STAFF				E.O.R.		REVISION	
OFFICE	INITIAL	DATE	NO.	DATE	INITIALS	DESCRIPTION	DATE
ENGINEERING DIVISION MANAGER							
LAND DEVELOPMENT							
PLANNING							
TRANSPORTATION							
PARKS AND COMMUNITY SERVICES							
SPECIAL DISTRICTS							
STORM WATER MANAGEMENT PROGRAM							

LANDSCAPE ARCHITECT OF RECORD'S SEAL

REGISTERED LANDSCAPE ARCHITECT
SHANNON P. KARLSON
10/31/23
8/21/23
DATE

bmla
LANDSCAPE ARCHITECTURE
310 NORTH JOY STREET | CORONA, CA 92629
TEL: 951.267.1124 | FAX: 951.267.6691

PLANS PREPARED UNDER THE SUPERVISION OF:
Shannon P. Karlson
SHANNON P. KARLSON
R.L.A. #6070 (EXP. 10/31/23) DATE: 8/21/23

CITY OF MORENO VALLEY

PUBLIC PARK IMPROVEMENT PLANS
TRACT 38236
STELLA PONTE & BELLA SERA
PLAYGROUND ENLARGEMENT PLAN

LH-3
SHEET 5 OF 23
CITY ID No: ---

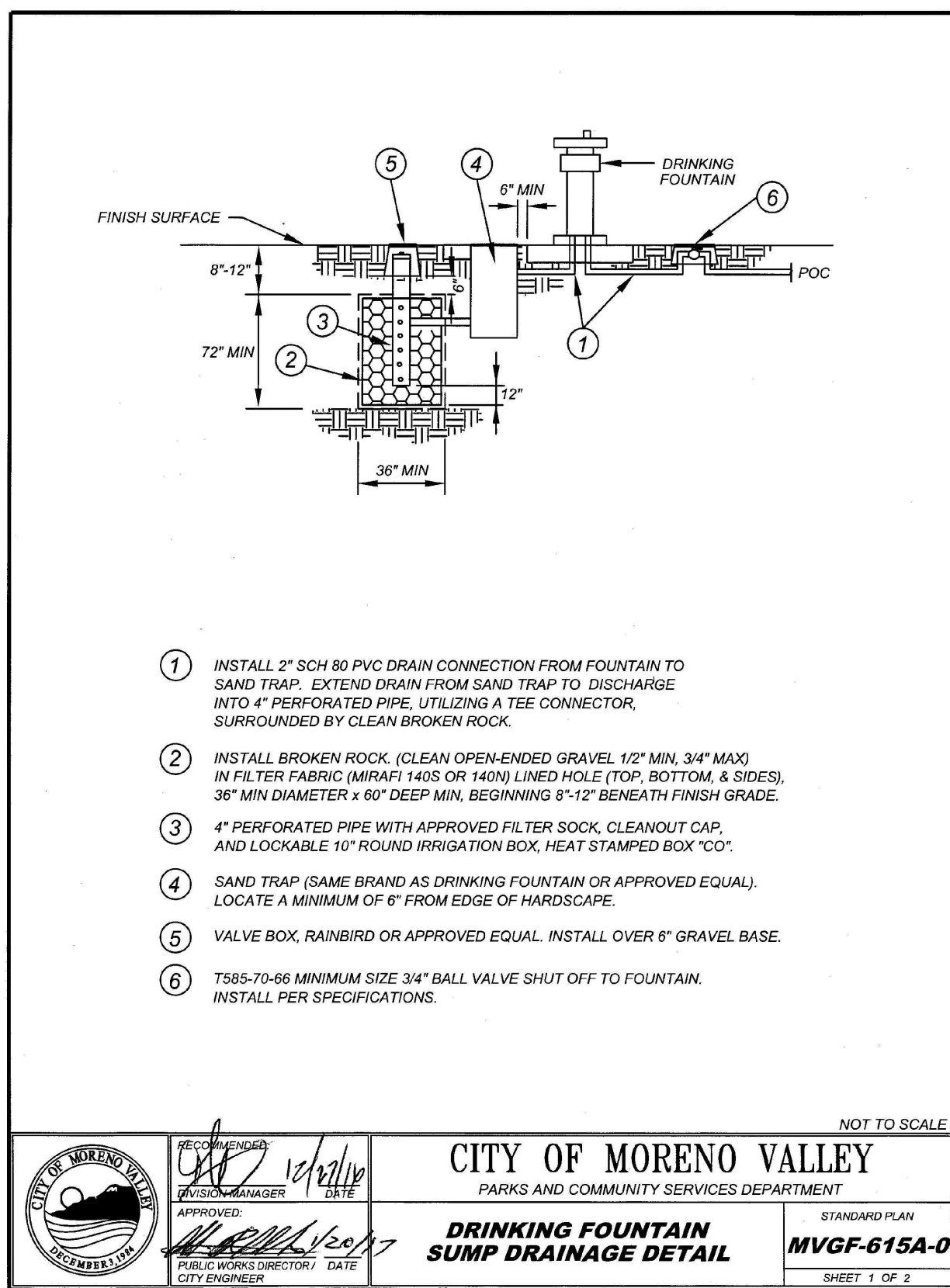

- INSTALL 2" SCH 80 PVC DRAIN CONNECTION FROM FOUNTAIN TO SAND TRAP. EXTEND DRAIN FROM SAND TRAP TO DISCHARGE INTO 4" PERFORATED PIPE UTILIZING A TEE CONNECTOR, SURROUNDED BY CLEAN BROKEN ROCK.
- INSTALL BROKEN ROCK (CLEAN OPEN-ENDED GRAVEL 1/2" MIN, 3/4" MAX) IN FILTER FABRIC (MIRAFI 140S OR 140N) LINED HOLE (TOP, BOTTOM, & SIDES), 38" MIN DIAMETER x 60" DEEP MIN. BEGINNING 8'-12" BENEATH FINISH GRADE.
- 4" PERFORATED PIPE WITH APPROVED FILTER SOCK, CLEANOUT CAP, AND LOCKABLE 1" ROUND IRRIGATION BOX, HEAT STAMPED BOX "CO".
- SAND TRAP (SAME BRAND AS DRINKING FOUNTAIN OR APPROVED EQUAL). LOCATE A MINIMUM OF 6" FROM EDGE OF HANDSCAPE.
- VALVE BOX, RAINBIRD OR APPROVED EQUAL. INSTALL OVER 6" GRADE BASE.
- 7585-70-66 MINIMUM SIZE 3/4" BALL VALVE SHUT OFF TO FOUNTAIN. INSTALL PER SPECIFICATIONS.

NOT TO SCALE

CITY OF MORENO VALLEY
PARKS AND COMMUNITY SERVICES DEPARTMENT

DRINKING FOUNTAIN
SUMP DRAINAGE DETAIL

STANDARD PLAN
MVGF-615A-0

SHEET 1 OF 2

1

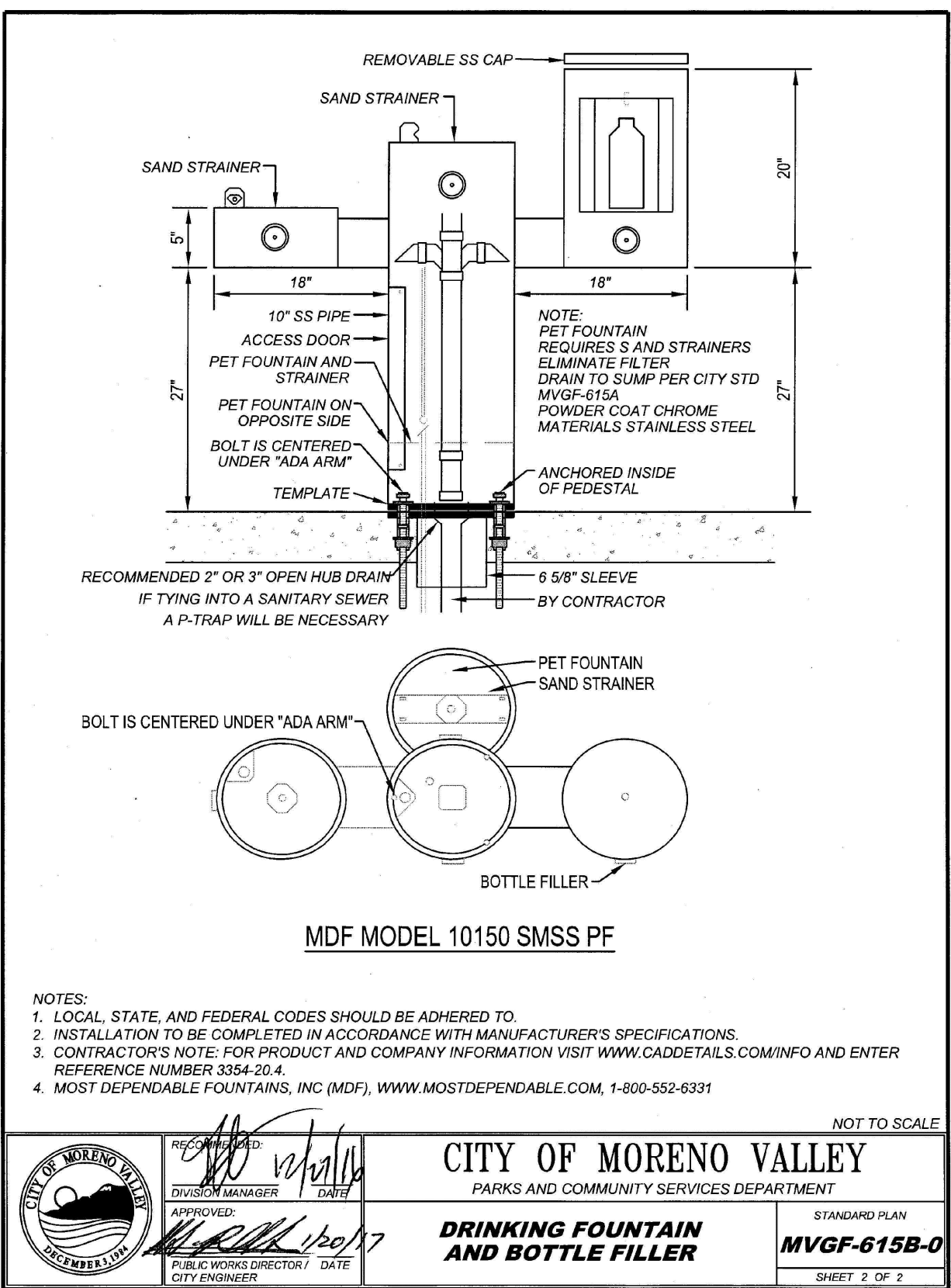

- NOTE: PET FOUNTAIN REQUIRES 5 SAND STRAINERS ELIMINATE FILTER DRAIN TO SUMP PER CITY STD MVGF-615A. POWDER COAT CHROME MATERIALS STAINLESS STEEL
- RECOMMENDED 2" OR 3" OPEN HUB DRAIN IF TYING INTO A SANITARY SEWER A P-TRAP WILL BE NECESSARY
- ANCHORED INSIDE OF PEDESTAL
- 6 5/8" SLEEVE BY CONTRACTOR
- BOLT IS CENTERED UNDER "ADA ARM"
- MDF MODEL 10150 SMSS PF

NOT TO SCALE

CITY OF MORENO VALLEY
PARKS AND COMMUNITY SERVICES DEPARTMENT

DRINKING FOUNTAIN
AND BOTTLE FILLER

STANDARD PLAN
MVGF-615B-0

SHEET 2 OF 2

2

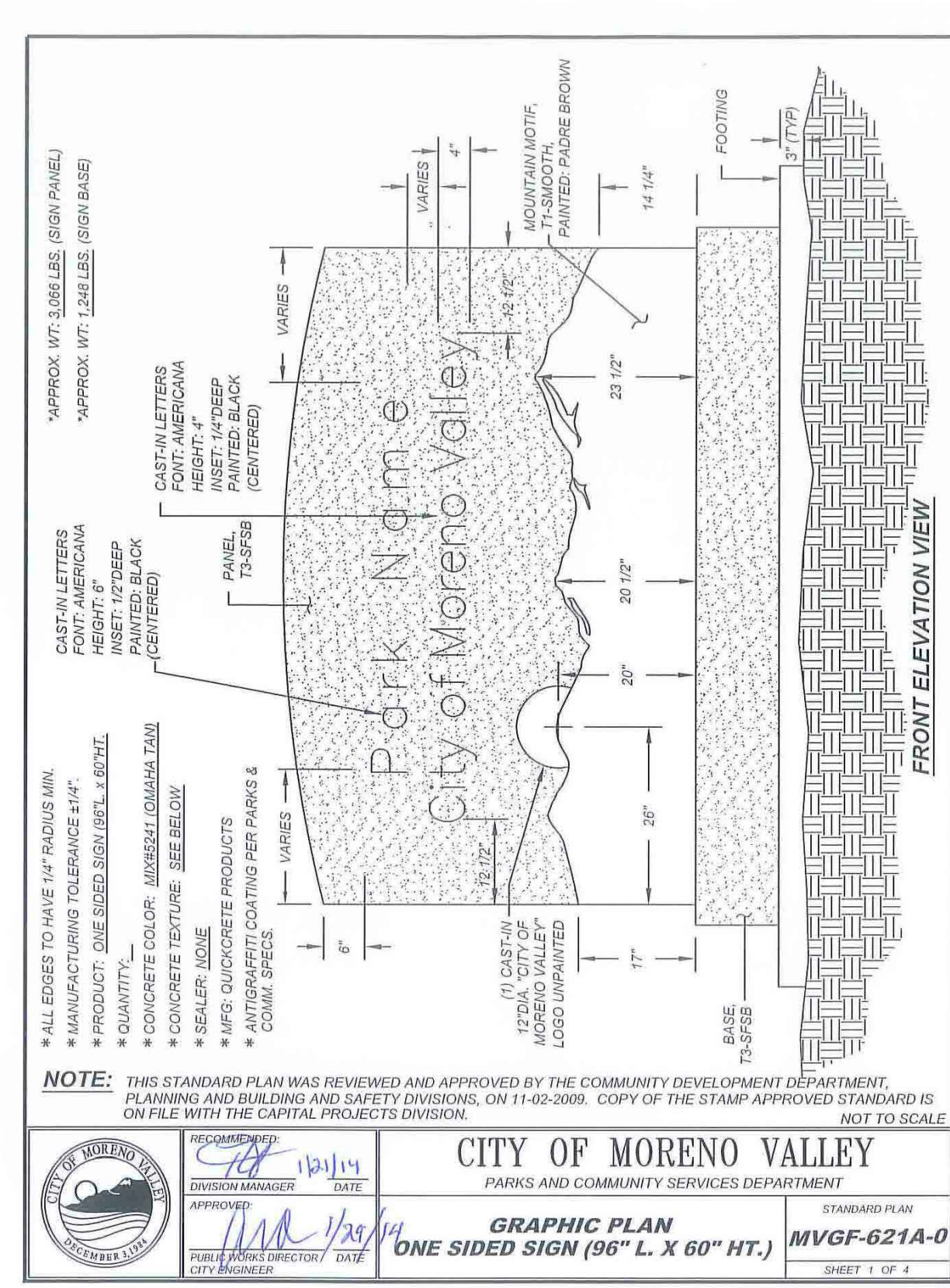

- NOTE: THIS STANDARD PLAN WAS REVIEWED AND APPROVED BY THE COMMUNITY DEVELOPMENT DEPARTMENT, PLANNING AND BUILDING AND SAFETY DIVISIONS, ON 11-02-2009. COPY OF THE STAMP APPROVED STANDARD IS ON FILE WITH THE CAPITAL PROJECTS DIVISION.
- NOT TO SCALE
- CITY OF MORENO VALLEY
PARKS AND COMMUNITY SERVICES DEPARTMENT
- GRAPHIC PLAN
ONE SIDED SIGN (96" L. X 60" H.T.)
- STANDARD PLAN
MVGF-621A-0
- SHEET 1 OF 4

3

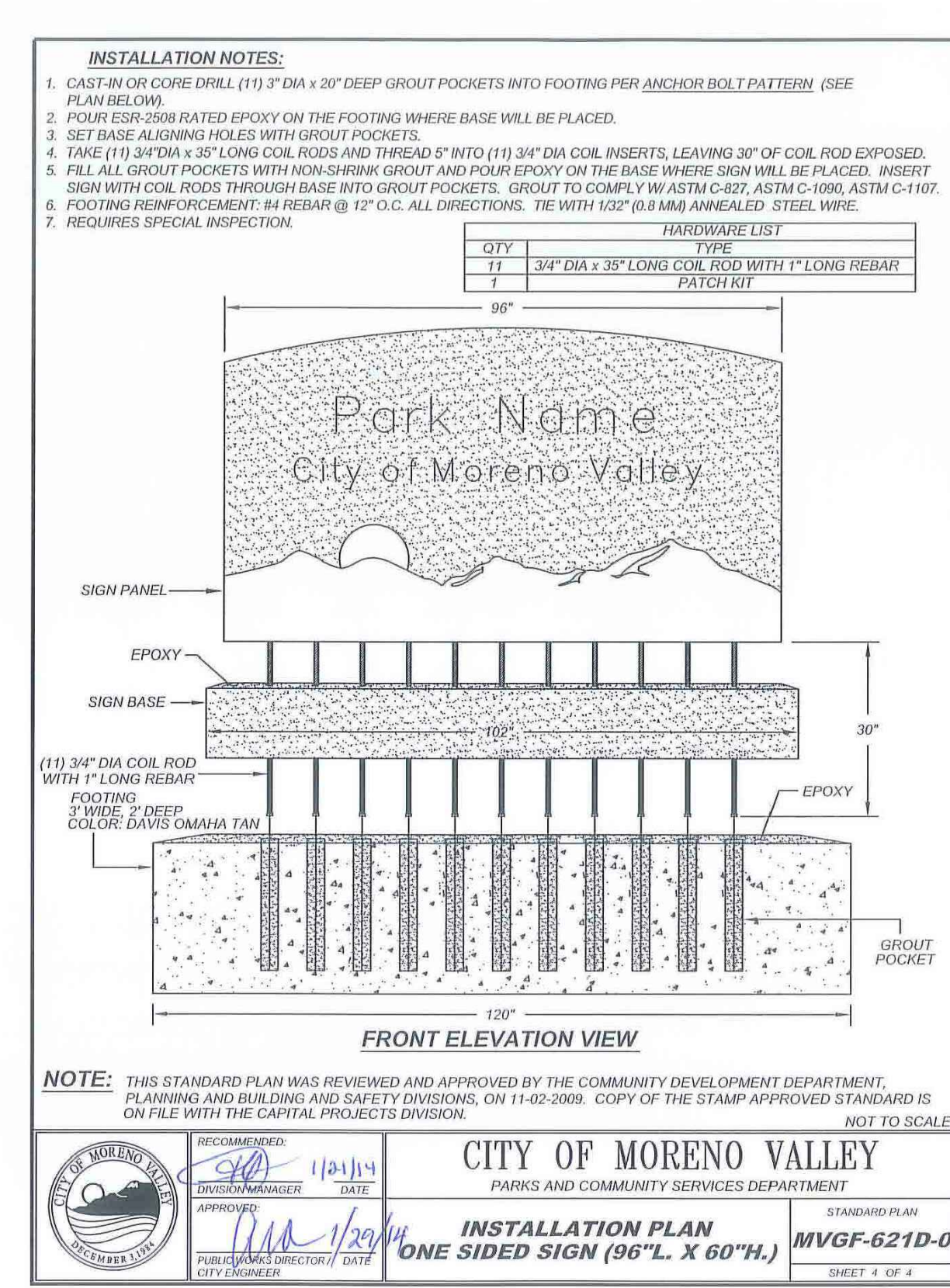

- INSTALLATION NOTES:
- CAST-IN OR CORE DRILL (1) 3" DIA x 20" DEEP GROUT POCKETS INTO FOOTING PER ANCHOR BOLT PATTERN (SEE PLAN BELOW).
 - POUR EPOXY-REINFORCED EPOXY ON THE FOOTING WHERE BASE WILL BE PLACED.
 - SET BASE ALIGNING HOLES WITH GROUT POCKETS.
 - TAKE (1) 3/4" DIA x 35" LONG COIL RODS AND THREAD 5" INTO (1) 3/4" DIA COIL INSERTS, LEAVING 30" OF COIL ROD EXPOSED.
 - FILL ALL GROUT POCKETS WITH NON-SHrink GROUT AND POUR EPOXY ON THE BASE WHERE SIGN WILL BE PLACED. INSERT SIGN WITH COIL RODS THROUGH BASE INTO GROUT POCKETS. GROUT TO COMPLY W/ ASTM C-827, ASTM C-1090, ASTM C-1107.
 - FOOTING REINFORCEMENT: #4 REBAR @ 12" O.C. ALL DIRECTIONS. TIE WITH #3 @ 0.9 MM ANNEALED STEEL WIRE.
 - REQUIRES SPECIAL INSPECTION.
- NOTE: THIS STANDARD PLAN WAS REVIEWED AND APPROVED BY THE COMMUNITY DEVELOPMENT DEPARTMENT, PLANNING AND BUILDING AND SAFETY DIVISIONS, ON 11-02-2009. COPY OF THE STAMP APPROVED STANDARD IS ON FILE WITH THE CAPITAL PROJECTS DIVISION.
- NOT TO SCALE
- CITY OF MORENO VALLEY
PARKS AND COMMUNITY SERVICES DEPARTMENT
- INSTALLATION PLAN
ONE SIDED SIGN (96" L. X 60" H.T.)
- STANDARD PLAN
MVGF-621D-0
- SHEET 4 OF 4

4

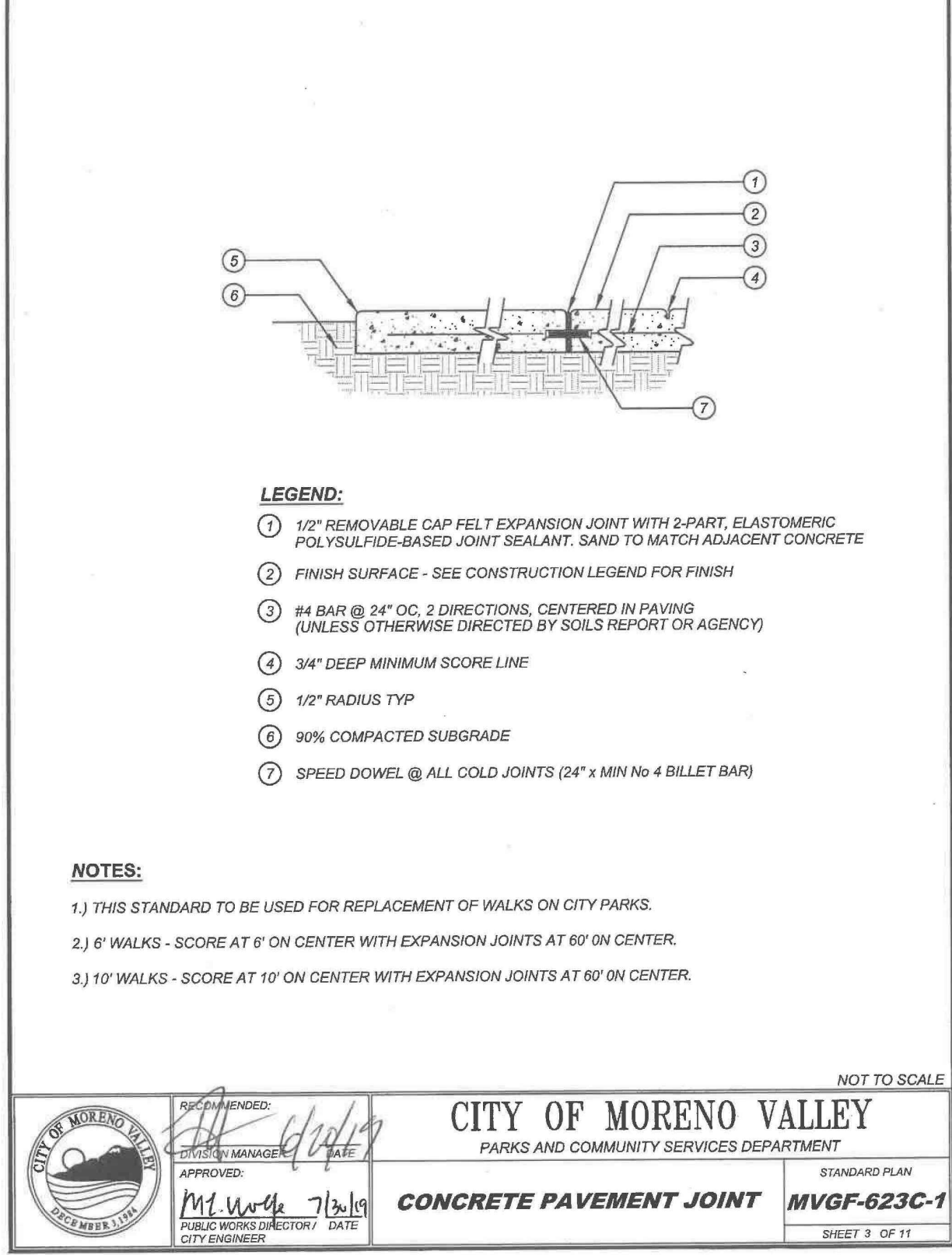

- LEGEND:
- 12" REMOVABLE CAP FELT EXPANSION JOINT WITH 2-PART, ELASTOMERIC POLYURETHANE-BASED JOINT SEALANT, SAND TO MATCH ADJACENT CONCRETE
 - FINISH SURFACE - SEE CONSTRUCTION LEGEND FOR FINISH
 - #4 BAR @ 24" OC, 2 DIRECTIONS, CENTERED IN PAVING (UNLESS OTHERWISE DIRECTED BY SOILS REPORT OR AGENCY)
 - 34" DEEP MINIMUM SCORE LINE
 - 12" RADIUS TYP
 - 90% COMPACTED SUBGRADE
 - SPEED DOWEL @ ALL COLD JOINTS (24" x MIN #4 BILLET BAR)

NOT TO SCALE

CITY OF MORENO VALLEY
PARKS AND COMMUNITY SERVICES DEPARTMENT

CONCRETE PAVEMENT JOINT

STANDARD PLAN
MVGF-623C-1

SHEET 3 OF 11

5

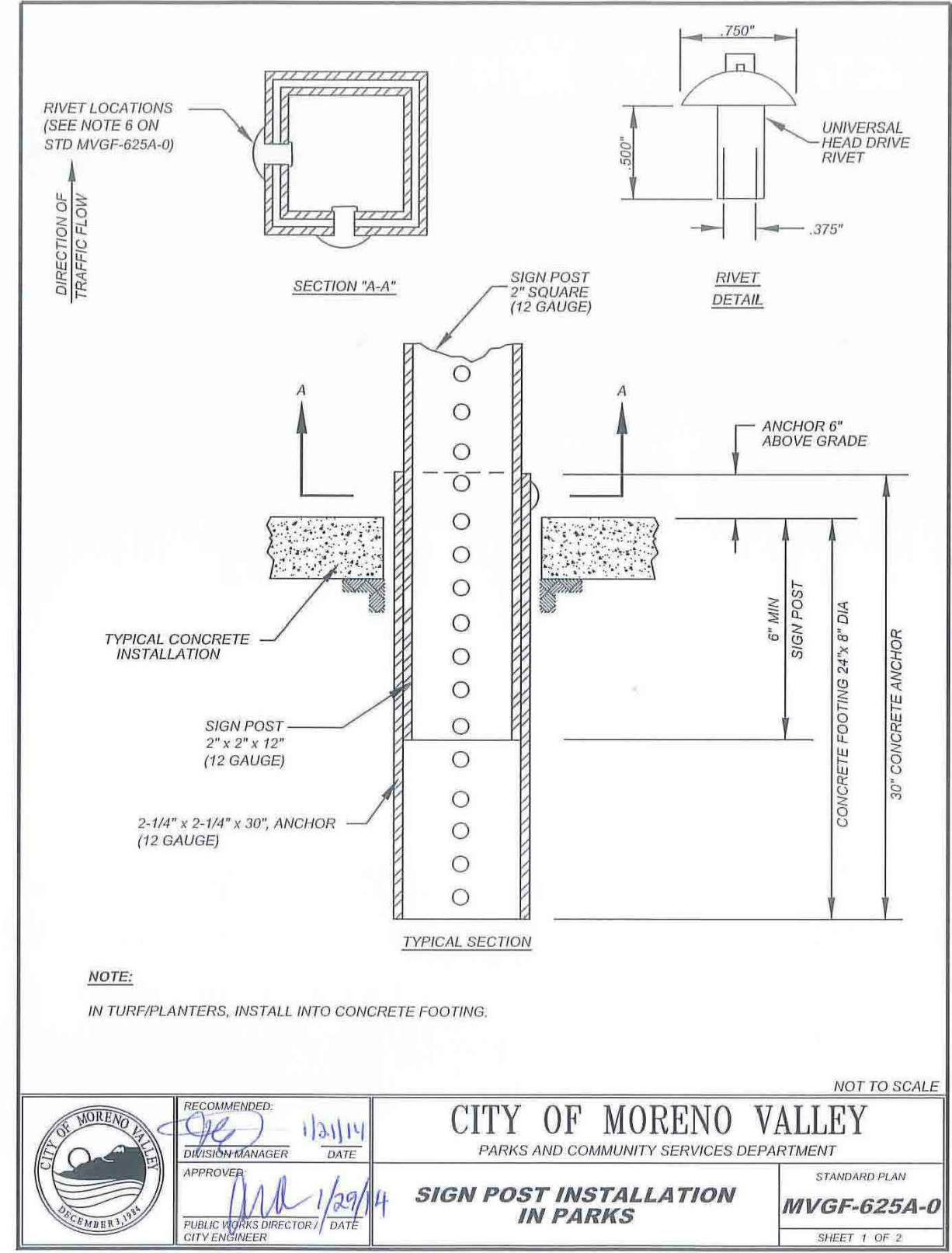

- NOTE: IN TURF/PLANTERS, INSTALL INTO CONCRETE FOOTING.
- NOTE: THIS STANDARD PLAN WAS REVIEWED AND APPROVED BY THE COMMUNITY DEVELOPMENT DEPARTMENT, PLANNING AND BUILDING AND SAFETY DIVISIONS, ON 11-02-2009. COPY OF THE STAMP APPROVED STANDARD IS ON FILE WITH THE CAPITAL PROJECTS DIVISION.
- NOT TO SCALE
- CITY OF MORENO VALLEY
PARKS AND COMMUNITY SERVICES DEPARTMENT
- SIGN POST INSTALLATION
IN PARKS
- STANDARD PLAN
MVGF-625A-0
- SHEET 1 OF 2

6

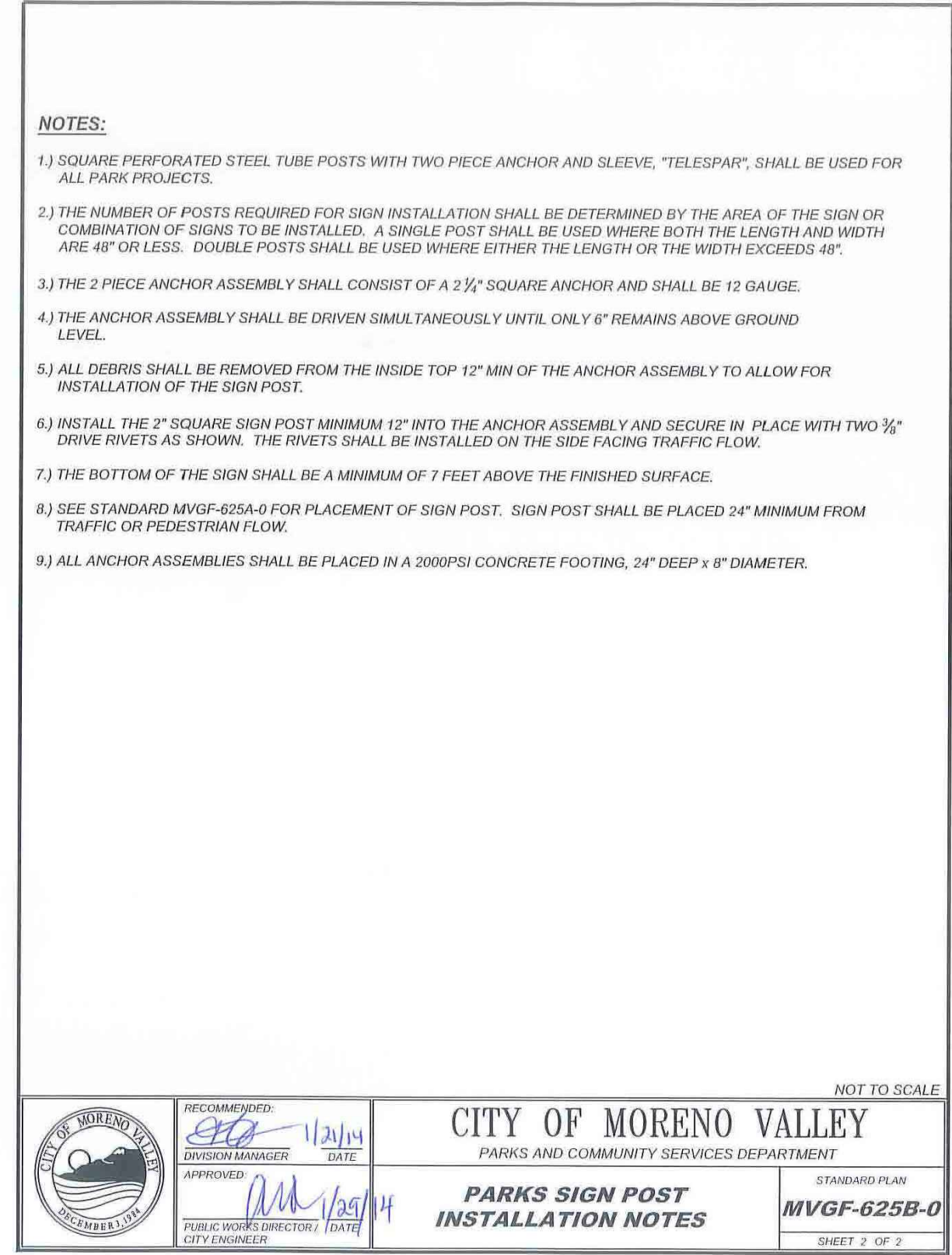

- NOTES:
- SQUARE PERFORATED STEEL TUBE POSTS WITH TWO PIECE ANCHOR AND SLEEVE, "TELESPEAR", SHALL BE USED FOR ALL PARK PROJECTS.
 - THE NUMBER OF POSTS REQUIRED FOR SIGN INSTALLATION SHALL BE DETERMINED BY THE AREA OF THE SIGN OR COMBINATION OF SIGNS TO BE INSTALLED. A SINGLE POST SHALL BE USED WHERE BOTH THE LENGTH AND WIDTH ARE 48" OR LESS. DOUBLE POSTS SHALL BE USED WHERE EITHER THE LENGTH OR THE WIDTH EXCEEDS 48".
 - THE 2 PIECE ANCHOR ASSEMBLY SHALL CONSIST OF 2 1/2" SQUARE ANCHOR AND SHALL BE 12 GAUGE.
 - THE ANCHOR ASSEMBLY SHALL BE DRIVEN SIMULTANEOUSLY UNTIL ONLY 6" REMAINS ABOVE GROUND LEVEL.
 - ALL DEBRIS SHALL BE REMOVED FROM THE INSIDE TOP 12" MIN OF THE ANCHOR ASSEMBLY TO ALLOW FOR INSTALLATION OF THE SIGN POST.
 - INSTALL THE 2" SQUARE SIGN POST MINIMUM 12" INTO THE ANCHOR ASSEMBLY AND SECURE IN PLACE WITH TWO 3/8" DRIVE RIVETS AS SHOWN. THE RIVETS SHALL BE INSTALLED ON THE SIDE FACING TRAFFIC FLOW.
 - THE BOTTOM OF THE SIGN SHALL BE A MINIMUM OF 7 FEET ABOVE THE FINISHED SURFACE.
 - SEE STANDARD MVGF-625A-0 FOR PLACEMENT OF SIGN POST. SIGN POST SHALL BE PLACED 24" MINIMUM FROM TRAFFIC OR PEDESTRIAN FLOW.
 - ALL ANCHOR ASSEMBLIES SHALL BE PLACED IN A 2000PSI CONCRETE FOOTING, 24" DEEP x 8" DIAMETER.
- NOTE: THIS STANDARD PLAN WAS REVIEWED AND APPROVED BY THE COMMUNITY DEVELOPMENT DEPARTMENT, PLANNING AND BUILDING AND SAFETY DIVISIONS, ON 11-02-2009. COPY OF THE STAMP APPROVED STANDARD IS ON FILE WITH THE CAPITAL PROJECTS DIVISION.
- NOT TO SCALE
- CITY OF MORENO VALLEY
PARKS AND COMMUNITY SERVICES DEPARTMENT
- PARKS SIGN POST
INSTALLATION NOTES
- STANDARD PLAN
MVGF-625B-0
- SHEET 2 OF 2

7

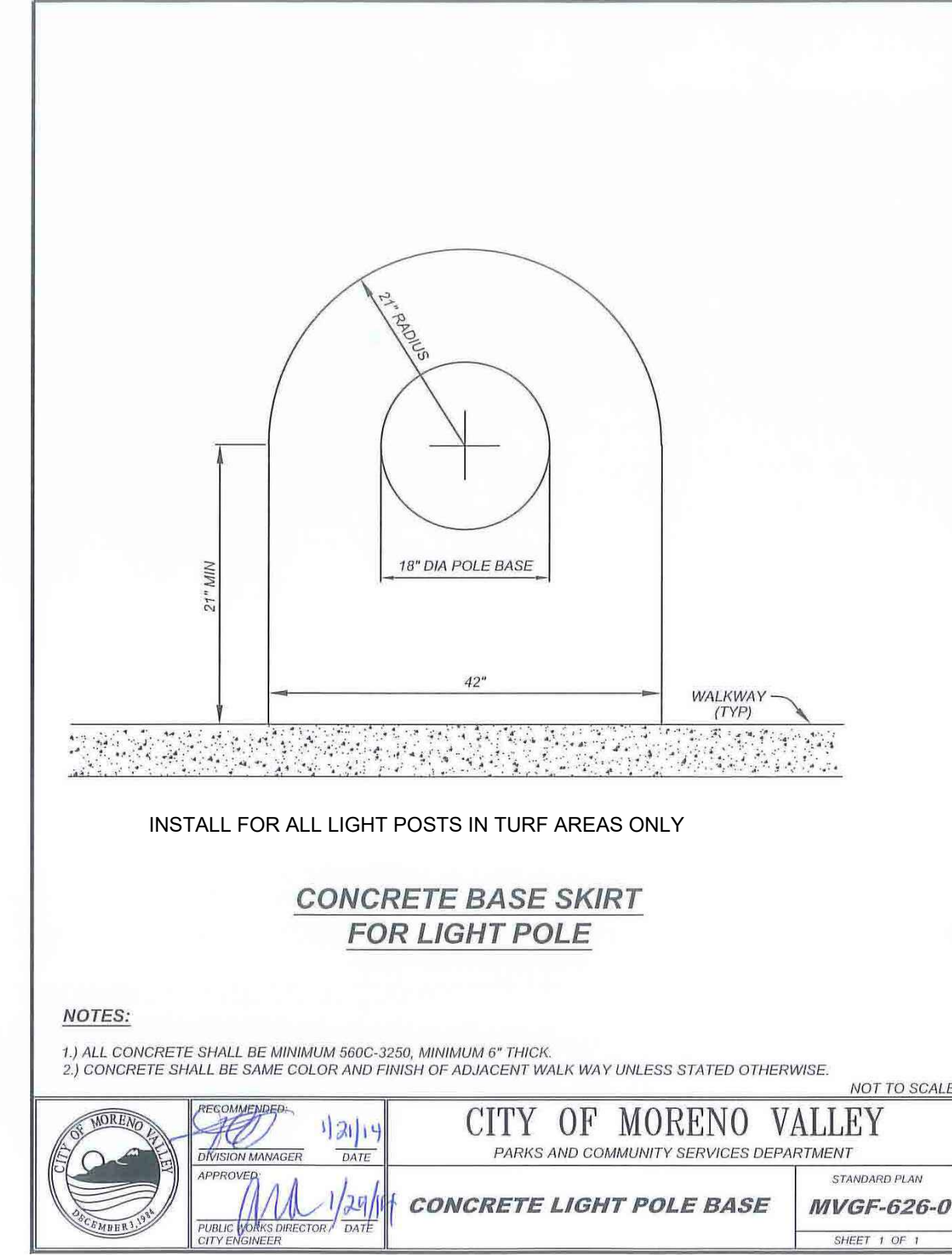

- INSTALL FOR ALL LIGHT POSTS IN TURF AREAS ONLY
- CONCRETE BASE SKIRT
FOR LIGHT POLE
- NOTE: THIS STANDARD PLAN WAS REVIEWED AND APPROVED BY THE COMMUNITY DEVELOPMENT DEPARTMENT, PLANNING AND BUILDING AND SAFETY DIVISIONS, ON 11-02-2009. COPY OF THE STAMP APPROVED STANDARD IS ON FILE WITH THE CAPITAL PROJECTS DIVISION.
- NOT TO SCALE
- CITY OF MORENO VALLEY
PARKS AND COMMUNITY SERVICES DEPARTMENT
- CONCRETE LIGHT POLE BASE
- STANDARD PLAN
MVGF-626-0
- SHEET 1 OF 1

8

<p>NO WORK SHALL BE DONE ON THIS SITE UNTIL BELOW AGENCY IS NOTIFIED OF INTENTION TO GRADE OR EXCAVATE.</p> <p>Underground Service Alert Call: TOLL FREE 811</p> <p>WWW.CALL811.COM TWO WORKING DAYS BEFORE YOU DIG</p>	<p>BASIS OF BEARING</p> <p>THE BASIS OF BEARINGS FOR THIS SURVEY IS THE CALIFORNIA STATE PLANE COORDINATE SYSTEM CCS83, ZONE 6, BASED LOCALLY ON CONTROL STATIONS "TR45", "TR46", AND "SR02" NAD 83 (NRSR2011) EPOCH 2010.00 AS SHOWN HEREON. ALL BEARINGS SHOWN ON THIS MAP ARE GRID. QUOTED BEARINGS AND DISTANCES FROM REFERENCE MAPS OR DEEDS ARE, AS SHOWN PER THAT RECORD REFERENCE. ALL DISTANCES SHOWN ARE GROUND DISTANCES UNLESS SPECIFIED OTHERWISE. GRID DISTANCES MAY BE OBTAINED BY MULTIPLYING THE GROUND DISTANCE BY A COMBINATION FACTOR OF 0.99993579. CALCULATIONS ARE MADE AT TYP. TAGGED "LS 5174", DOWN 0.2' IN WELL PER TRACT 36882, MB 454-07-39 WITH COORDINATES OF: N: 227736.255000000, E: 6286431.21000000 USING AN ELEVATION OF 1665.533</p>	<p>REVIEW BY CITY STAFF</p> <table border="1"> <tr> <th>OFFICE</th> <th>INITIAL</th> <th>DATE</th> </tr> <tr> <td>ENGINEERING DIVISION MANAGER</td> <td></td> <td></td> </tr> <tr> <td>LAND DEVELOPMENT</td> <td></td> <td></td> </tr> <tr> <td>PLANNING</td> <td></td> <td></td> </tr> <tr> <td>TRANSPORTATION</td> <td></td> <td></td> </tr> <tr> <td>PARKS AND COMMUNITY SERVICES</td> <td></td> <td></td> </tr> <tr> <td>SPECIAL DISTRICTS</td> <td></td> <td></td> </tr> <tr> <td>STORM WATER MANAGEMENT PROGRAM</td> <td></td> <td></td> </tr> </table>	OFFICE	INITIAL	DATE	ENGINEERING DIVISION MANAGER			LAND DEVELOPMENT			PLANNING			TRANSPORTATION			PARKS AND COMMUNITY SERVICES			SPECIAL DISTRICTS			STORM WATER MANAGEMENT PROGRAM			<table border="1"> <tr> <th>E.O.R.</th> <th>REVISION</th> <th>DATE</th> <th>APPR</th> </tr> <tr> <td></td> <td>DESCRIPTION</td> <td></td> <td></td> </tr> </table>	E.O.R.	REVISION	DATE	APPR		DESCRIPTION			<p>LANDSCAPE ARCHITECT OF RECORD'S SEAL</p> <p>bmla LANDSCAPE ARCHITECTURE 310 NORTH JOY STREET CORONA, CA 92607 TEL: 951.261.1291 FAX: 951.267.6697</p> <p>PLANS PREPARED UNDER THE SUPERVISION OF:</p> <p>SHANNON P. KARLSON R.L.A. #6070 (EXP. 10/31/23)</p> <p>8/21/23 DATE</p>	<p>CITY OF MORENO VALLEY</p> <p>PUBLIC PARK IMPROVEMENT PLANS TRACT 38236 STELLA PONTE & BELLA SERA</p> <p>HARDSCAPE DETAILS</p> <p>LHD-1</p> <p>SHEET 6 OF 23</p> <p>CITY ID No</p>
	OFFICE	INITIAL	DATE																																		
ENGINEERING DIVISION MANAGER																																					
LAND DEVELOPMENT																																					
PLANNING																																					
TRANSPORTATION																																					
PARKS AND COMMUNITY SERVICES																																					
SPECIAL DISTRICTS																																					
STORM WATER MANAGEMENT PROGRAM																																					
E.O.R.	REVISION	DATE	APPR																																		
	DESCRIPTION																																				

INDUSTRIAL STRENGTH STEEL

Standard Heights:
 4' (1219.2mm)
 5' (1524.0mm)
 6' (1828.8mm)
 7' (2133.6mm)
 8' (2438.4mm)
 9' (2743.2mm)
 10' (3048.0mm)

Notes:
 1.) Post size depends on fence height and wind loads. See AEGIS II post sizing chart.
 2.) Panels also available for 6' on center post spacing.
 3.) Additional heights available on request.
 4.) Third rail optional.

Values shown are nominal and not to be used for installation purposes. See product specification for installation requirements.

AMERISTAR®
 1555 N. Mingo
 Tulsa, OK 74116
 1-888-333-3422
 www.ameristarfence.com

AMERISTAR®
 1555 N. Mingo
 Tulsa, OK 74116
 1-888-333-3422
 www.ameristarfence.com

PROPRIETARY INFORMATION
 This drawing is the property of AMERISTAR®. It is not to be used for any other purpose without the written consent of AMERISTAR®.

REV. BY: FGS
 DATE: 11/07/07
 DRN BY: FGS
 CHK BY: RTM

TITLE: MONTAGE PLUS MAJESTIC 3R EXT 3' GAP ST 8' PANEL
 SCALE: DNS
 SHEET: 1/1
 REV: b

DRAWING NO: 1RMX258-3

FENCE NOTES:
 REFERENCE AMERISTAR FOR HARDWARE INSTALLATION / CONNECTIONS PER MANUFACTURER SPECS AND INSTRUCTIONS FOR DETAILS 1 & 2 THIS SHEET.

PLAQUE LAYOUT DETAIL
 PLAQUE MOUNTING DETAIL

NOTES:
 1. PLAQUE SHALL HAVE A SATIN FINISH WITH BROWN BACKGROUND AND LEATHERETTE TEXTURE AND PROTECTED WITH A CLEAR ACRYLIC COATING (THIS INCLUDES THE CITY SEAL).
 2. THE TYPE/STYLES USED FOR THESE PLAQUES ARE TIMES BOLD AND COPPERPLATE.
 3. THE LOCATION FOR THE PLAQUE TO BE DETERMINED BY APPLICABLE DEPARTMENT.
 4. PLAQUE EXTENSION (BELOW MAIN PLAQUE) IS TO BE USED WHEN APPLICABLE.
 5. MOUNTING STUDS MUST BE EMBEDDED A MINIMUM OF 1-1/2".
 6. MOUNTING STUDS SET IN WALL / PEDESTAL WITH APPROVED EPOXY.
 7. SEE STANDARD PLAN No MVGF-624A-0 FOR PLAQUE DIMENSIONS AND MAY BE MODIFIED ON A CASE BY CASE BASIS.
 8. DIMENSIONS AS RECOMMENDED BY MANUFACTURER.
 9. THE NAME OF THE ARCHITECT OR CONTRACTOR (OR BOTH) SHALL ONLY BE SHOWN ON THE PLAQUE IF THE ARCHITECT OR CONTRACTOR (OR BOTH) AGREES TO PAY FOR THE MATERIALS AND INSTALLATION COSTS OF THE PLAQUE.

CITY OF MORENO VALLEY
 PARKS AND COMMUNITY SERVICES DEPARTMENT
 PARKS FACILITY DEDICATION PLAQUE
 STANDARD PLAN MVGF-624A-0
 SHEET 1 OF 2

3

SIDE ELEVATION
 PLAN VIEW

LEGEND:
 1) DEDICATION PLAQUE
 2) FINISH TYPICALLY TO BE COLORED CONCRETE
 3) BASE MATERIAL & COMPACTED SUB-GRADE
 4) STRUCTURAL FOOTING - 3'-0" x 3'-0"
 5) No. 4 @ 12" OC EA WAY, TYP
 6) 4-No. 4 EA WAY, TYP

NOTES:
 1. ADJUST SURROUNDING IRRIGATION ACCORDINGLY, IF PLACED IN EXISTING LANDSCAPED AREA.
 2. SEAL ALL CONCRETE WITH APPROPRIATE SEALER MATERIAL.
 3. 1/8" RADIUS AT ALL CONCRETE EDGES/ CORNERS.

CITY OF MORENO VALLEY
 PARKS AND COMMUNITY SERVICES DEPARTMENT
 PARKS DEDICATION PLAQUE PEDESTAL
 STANDARD PLAN MVGF-624B-0
 SHEET 2 OF 2

4

1

2

NO WORK SHALL BE DONE ON THIS SITE UNTIL BELOW AGENCY IS NOTIFIED OF INTENTION TO GRADE OR EXCAVATE. Underground Service Alert Call: TOLL FREE 811 WWW.CALL811.COM TWO WORKING DAYS BEFORE YOU DIG	BASIS OF BEARING THE BASIS OF BEARINGS FOR THIS SURVEY IS THE CALIFORNIA STATE PLANE COORDINATE SYSTEM CCS83, ZONE 6, BASED LOCALLY ON CONTROL STATIONS "TR48", "TR47", AND "SBOC" NAD 83 (NRSR2011) EPOCH 2010.00 AS SHOWN HEREON. ALL BEARINGS SHOWN ON THIS MAP ARE GRID. QUOTED BEARINGS AND DISTANCES FROM REFERENCE MAPS OR DEEDS ARE AS SHOWN PER THAT RECORD REFERENCE. ALL DISTANCES SHOWN ARE GROUND DISTANCES UNLESS SPECIFIED OTHERWISE. GRID DISTANCES MAY BE OBTAINED BY MULTIPLYING THE GROUND DISTANCE BY A COMBINATION FACTOR OF 0.99999579. CALCULATIONS ARE MADE AT TYP TAGGED "LS 5174", DOWN 0.2" IN WELL PER TRACT 36882, MB 454-07--39 WITH COORDINATES OF: N: 227736.255000000, E: 6280431.21000000 USING AN ELEVATION OF 1665.533	REVIEW BY CITY STAFF <table border="1"> <tr> <th>OFFICE</th> <th>INITIAL</th> <th>DATE</th> <th>NO.</th> <th>DATE</th> <th>INITIALS</th> <th>E.O.R.</th> <th>REVISION</th> <th>DATE</th> <th>APPR</th> </tr> <tr> <td>ENGINEERING DIVISION MANAGER</td> <td></td> <td></td> <td></td> <td></td> <td></td> <td></td> <td></td> <td></td> <td></td> </tr> <tr> <td>LAND DEVELOPMENT</td> <td></td> <td></td> <td></td> <td></td> <td></td> <td></td> <td></td> <td></td> <td></td> </tr> <tr> <td>PLANNING</td> <td></td> <td></td> <td></td> <td></td> <td></td> <td></td> <td></td> <td></td> <td></td> </tr> <tr> <td>TRANSPORTATION</td> <td></td> <td></td> <td></td> <td></td> <td></td> <td></td> <td></td> <td></td> <td></td> </tr> <tr> <td>PARKS AND COMMUNITY SERVICES</td> <td></td> <td></td> <td></td> <td></td> <td></td> <td></td> <td></td> <td></td> <td></td> </tr> <tr> <td>SPECIAL DISTRICTS</td> <td></td> <td></td> <td></td> <td></td> <td></td> <td></td> <td></td> <td></td> <td></td> </tr> <tr> <td>STORM WATER MANAGEMENT PROGRAM</td> <td></td> <td></td> <td></td> <td></td> <td></td> <td></td> <td></td> <td></td> <td></td> </tr> </table>	OFFICE	INITIAL	DATE	NO.	DATE	INITIALS	E.O.R.	REVISION	DATE	APPR	ENGINEERING DIVISION MANAGER										LAND DEVELOPMENT										PLANNING										TRANSPORTATION										PARKS AND COMMUNITY SERVICES										SPECIAL DISTRICTS										STORM WATER MANAGEMENT PROGRAM										LANDSCAPE ARCHITECT OF RECORD'S SEAL REGISTERED LANDSCAPE ARCHITECT SHANNON P. KARLSON R.L.A. #6070 (EXP. 10/31/23)	bmla LANDSCAPE ARCHITECTURE 310 NORTH JOY STREET CORONA, CA 92607 TEL: 951.267.1124 FAX: 951.267.6697 PLANS PREPARED UNDER THE SUPERVISION OF: SHANNON P. KARLSON R.L.A. #6070 (EXP. 10/31/23)	CITY OF MORENO VALLEY PUBLIC PARK IMPROVEMENT PLANS TRACT 38236 STELLA POINTE & BELLA SERA HARDSCAPE DETAILS	LHD-2 SHEET 7 OF 23 CITY ID No: ---
	OFFICE	INITIAL	DATE	NO.	DATE	INITIALS	E.O.R.	REVISION	DATE	APPR																																																																												
ENGINEERING DIVISION MANAGER																																																																																						
LAND DEVELOPMENT																																																																																						
PLANNING																																																																																						
TRANSPORTATION																																																																																						
PARKS AND COMMUNITY SERVICES																																																																																						
SPECIAL DISTRICTS																																																																																						
STORM WATER MANAGEMENT PROGRAM																																																																																						

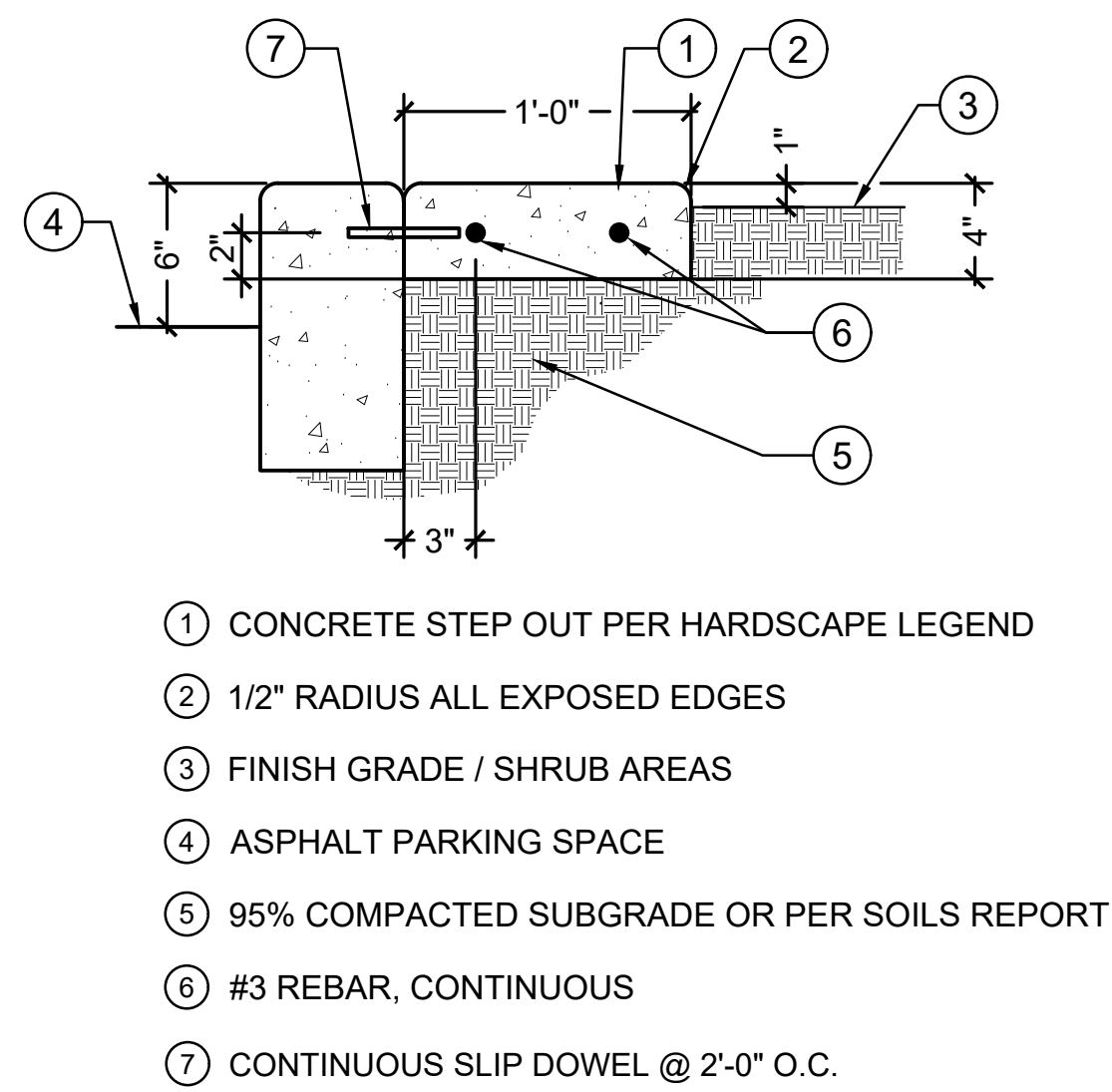

1 CONCRETE PARKING STEP OUT DETAIL
1 1/2" = 1'-0"

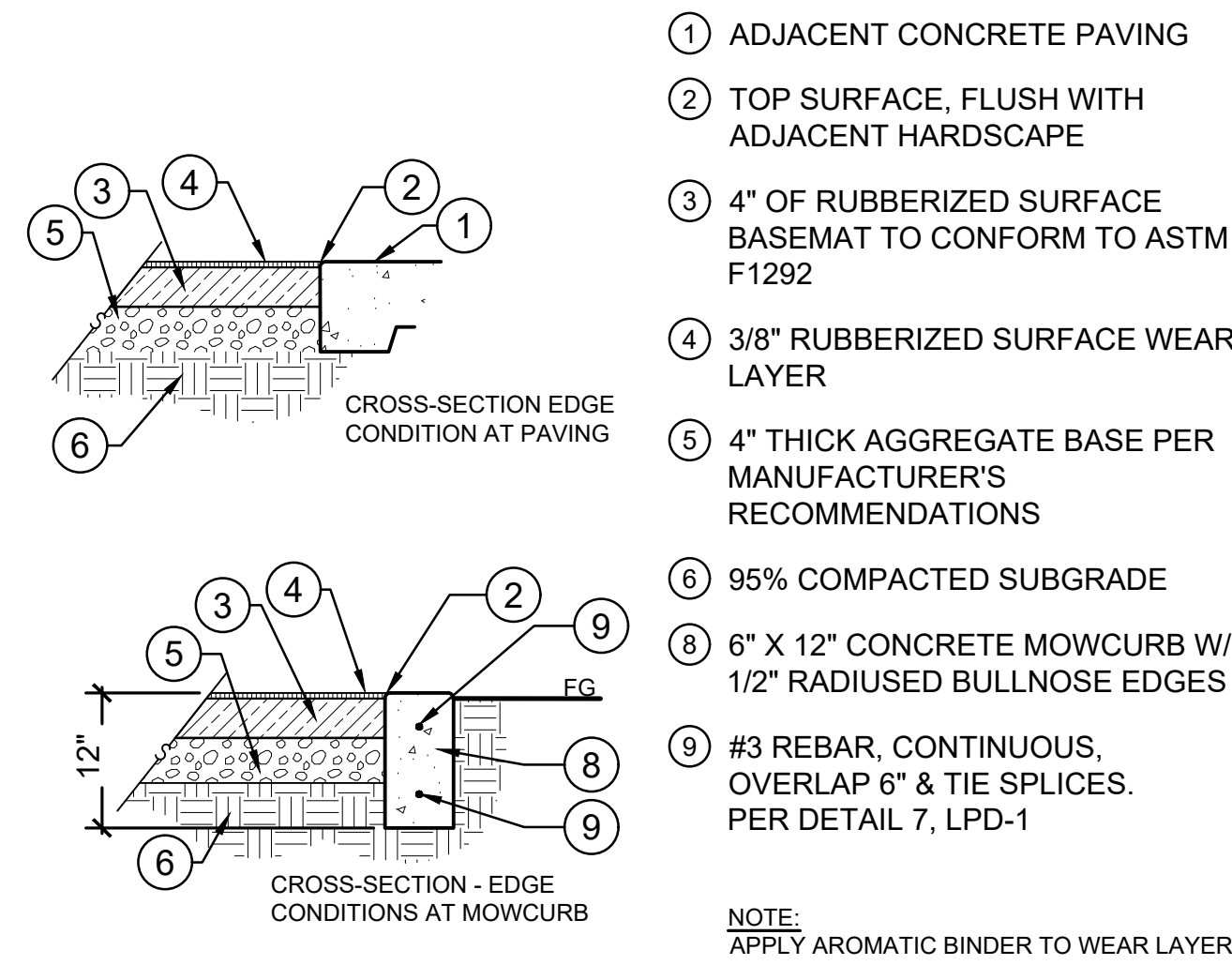

2 EXERCISE STATION SURFACING & CURB DETAIL
3/4" = 1'-0"

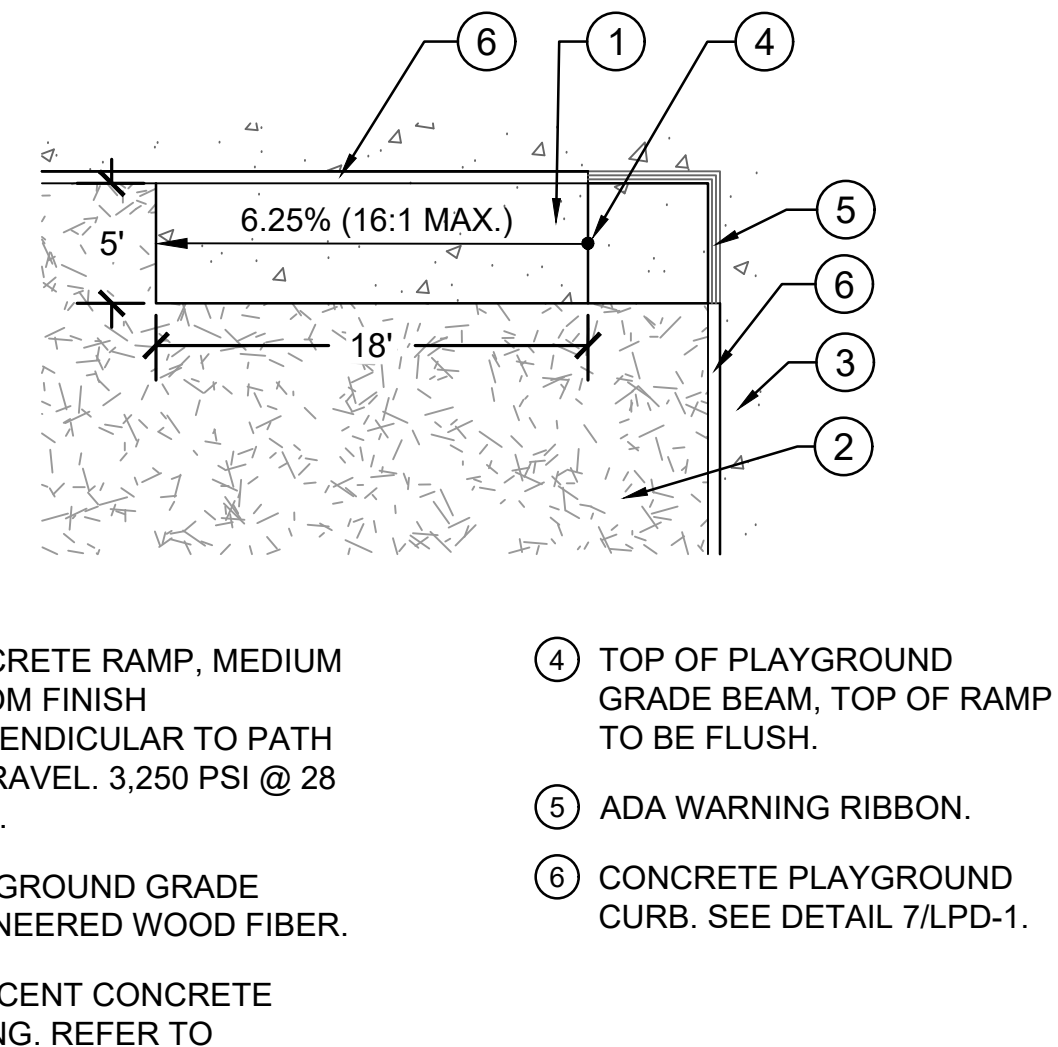

3 PLAYGROUND ADA RAMP
1/8" = 1'-0"

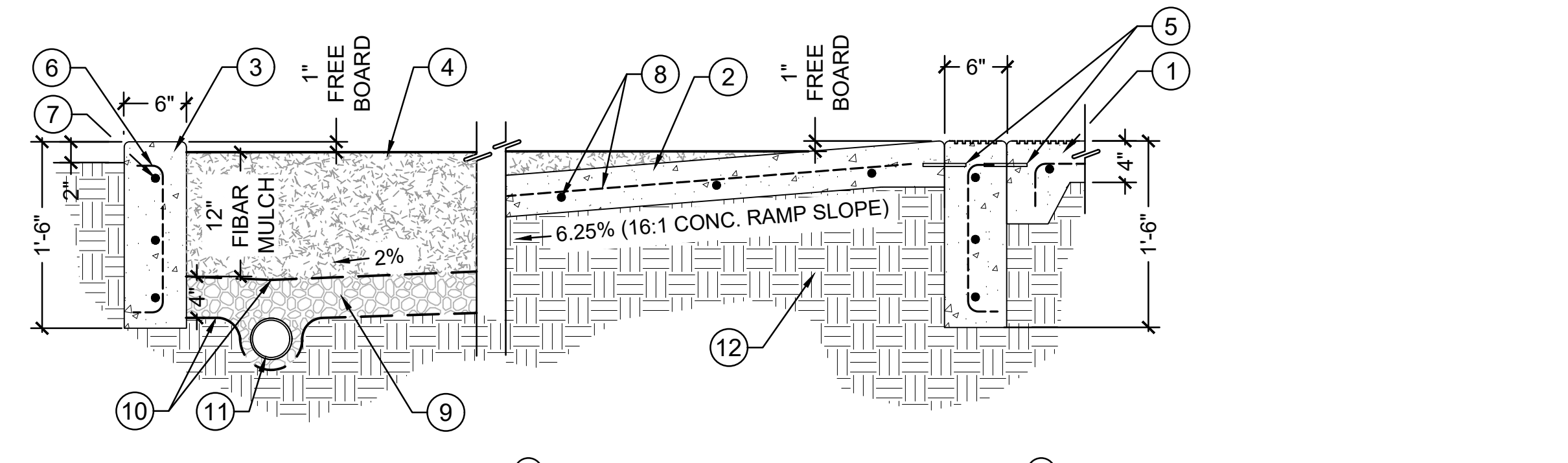

4 PLAYGROUND CURB WITH FIBAR MULCH
1" = 1'-0"

- 1 ADJACENT PAVING WITH THICKENED EDGE.
- 2 4" THICK MIN. CONCRETE RAMP, MEDIUM BROOM FINISH PERPENDICULAR TO PATH OF TRAVEL.
- 3 2500 PSI PLAYGROUND CURB 6" WIDE MIN. BY 18" DEEP W/ 1/2" TOOLED JOINTS PER PLAN, OTHERWISE AT 3'-0" O.C. MIN.
- 4 FIBARSYSTEM 100 ENGINEERED PLAYGROUND MULCH BY FIBAR TO COMPLY W/ ASTM PLAYGROUND STANDARDS FOR ADA ACCESS MAINTAINED AT A DEPTH OF 12". FIBAR MULCH MUST BE WATERED, COMPACTED AND REPLENISHED TO BE 1" BELOW TOP OF CURB. INSTALL PER MANUFACTURER SPECIFICATIONS.
- 5 CONTINUOUS SLIP DOWEL 2'-0" O.C.
- 6 #4 REBAR AT 36" O.C.
- 7 CONTINUOUS #4 REBAR AT 3 PLACES.
- 8 #3 REBAR 36" O.C. BOTH WAYS (AT RAMP).
- 9 CLASS II AGGREGATE BASE SLOPING 2% TO FRENCH DRAIN
- 10 FIBARFELT GEOTEXTILE FABRIC. INSTALL PER MANUFACTURER SPECIFICATIONS.
- 11 4" DIA. PERFORATED DRAIN PIPE WRAPPED IN MIRAFI 140N FILTER FABRIC. REFERENCE CIVIL ENGINEER'S PLAN FOR LOCATION AND FURTHER INFO.
- 12 COMPACTED SUBGRADE (95%) PER GEOTECHNICAL REPORT.

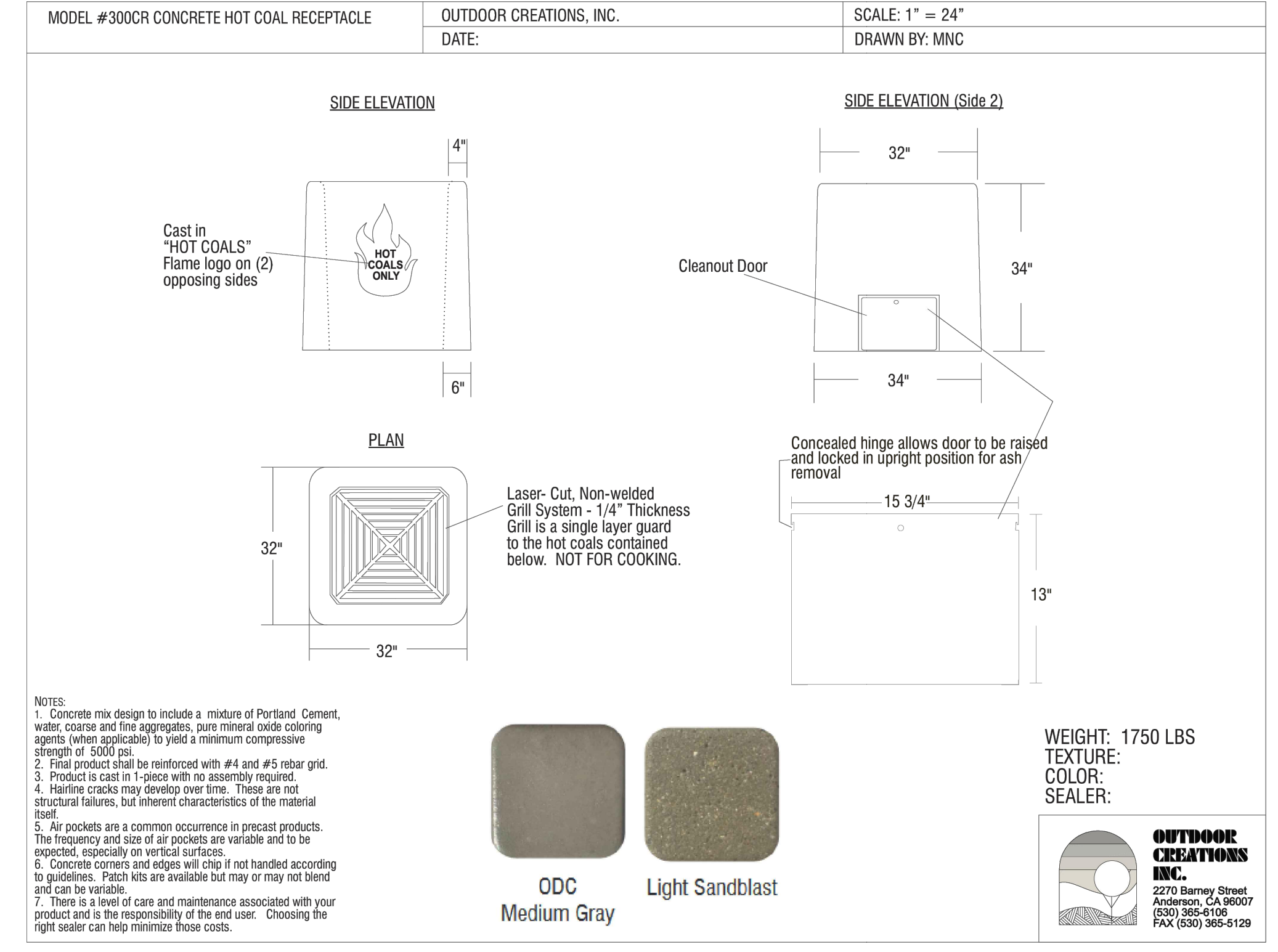

5 HOT COAL RECEPTACLE
OUTDOOR CREATIONS

<p>NO WORK SHALL BE DONE ON THIS SITE UNTIL BELOW AGENCY IS NOTIFIED OF INTENTION TO GRADE OR EXCAVATE.</p> <p>Underground Service Alert Call: TOLL FREE 811</p> <p>WWW.CALL811.COM TWO WORKING DAYS BEFORE YOU DIG</p>	<p>THE BASIS OF BEARINGS FOR THIS SURVEY IS THE CALIFORNIA STATE PLANE COORDINATE SYSTEM CCS83, ZONE 6, BASED LOCALLY ON CONTROL STATIONS "TR48", "TR47", AND "SBC0" NAD 83 (NRSR2011) EPOCH 2010.00 AS SHOWN HEREON. ALL BEARINGS SHOWN ON THIS MAP ARE GRID. QUOTED BEARINGS AND DISTANCES FROM REFERENCE MAPS OR DEEDS ARE AS SHOWN PER THAT RECORD. REFERENCE ALL DISTANCES SHOWN ARE GROUND DISTANCES UNLESS SPECIFIED OTHERWISE. GRID DISTANCES MAY BE OBTAINED BY MULTIPLYING THE GROUND DISTANCE BY A COMBINATION FACTOR OF 0.999993579. CALCULATIONS ARE MADE AT 1"= 36" TAGGED "LS 5174", DOWN 0.2" IN WELL PER TRACT 36882, MB 454-07--39 WITH COORDINATES OF N: 227736.255000000, E: 6280631.210000000 USING AN ELEVATION OF 1665.533</p>	REVIEW BY CITY STAFF		E.O.R.		REVISION			
		OFFICE	INITIAL	DATE	NO.	DATE	INITIALS	DESCRIPTION	DATE
ENGINEERING DIVISION MANAGER									
LAND DEVELOPMENT									
PLANNING									
TRANSPORTATION									
PARKS AND COMMUNITY SERVICES									
SPECIAL DISTRICTS									
STORM WATER MANAGEMENT PROGRAM									

LANDSCAPE ARCHITECT OF RECORD'S SEAL

bmla
LANDSCAPE ARCHITECTURE
310 NORTH JOY STREET | LOS ANGELES, CA 90070
TEL: 951.261.1124 | FAX: 951.267.6697

PLANS PREPARED UNDER THE SUPERVISION OF:

Shannon P. Karlson
SIGNATURE
10/31/23
DATE

SHANNON P. KARLSON
R.L.A. #6070 (EXP. 10/31/23)

8/21/23
DATE

CITY OF MORENO VALLEY

PUBLIC PARK IMPROVEMENT PLANS
TRACT 38236
STELLA PONTE & BELLA SERA

HARDSCAPE DETAILS

LHD-3

SHEET 8 OF 23

CITY ID No

MODEL #402SK CONCRETE FLAT BENCH WITH SKATE DETERRENT BUMPS

OUTDOOR CREATIONS, INC. CUSTOMER APPROVAL x

SCALE: 1" = 18" DRAWN BY: MNC

ODC Medium Gray

Light Sandblast

Integrally Cast Anti-Skateboard System

Threaded inserts in legs for mounting dowels (1 per leg)

NOTES:
 1. Concrete mix design to include a mixture of Portland Cement, water, coarse and fine aggregates, pure mineral oxide coloring agents (when applicable) to yield a minimum compressive strength of 5000 psi.
 2. Final product shall be reinforced with #4 and #5 rebar grid.
 3. Product is cast in 1-piece with no assembly required.
 4. Hairline cracks may develop over time. These are not structural failures, but inherent characteristics of the material itself.
 5. Air pockets are a common occurrence in precast products. The frequency and size of air pockets are variable and to be expected, especially on vertical surfaces.
 6. Concrete corners and edges will chip if not handled according to guidelines. Patch kits are available but may or may not blend and can be variable.
 7. There is a level of care and maintenance associated with your product and is the responsibility of the end user. Choosing the right sealer can help minimize those costs.

BENCH INSTALLATION:
 This bench model will have cast in threaded inserts in the bottom of each leg. Bench will be supplied with colored for mechanical attachment, as an additional security method.
 ** Bench requires epoxy applied to cover bottom of entire leg. Epoxy adhesive should be checked periodically to ensure continued adhesion.

* (2) 3/4" x 8" coils provided per bench for mounting
***Bench MUST be mechanically attached.**

WEIGHT: 410 LBS
 TEXTURE:
 COLOR:
 SEALER:

OUTDOOR CREATIONS INC.
 2270 Barney Street
 Anderson, CA 96007
 (530) 365-6106
 FAX (530) 365-5129

MODEL #100FSK CONCRETE PICNIC TABLE WITH SKATE DETERRENTS

OUTDOOR CREATIONS, INC. DATE:

SCALE: 1" = 32" DRAWN BY: MNC

Integrally Cast Anti-Skateboard System

NOTES:
 1. Concrete mix design to include a mixture of Portland Cement, water, coarse and fine aggregates, pure mineral oxide coloring agents (when applicable) to yield a minimum compressive strength of 5000 psi.
 2. Final product shall be reinforced with #4 and #5 rebar grid.
 3. Product is cast in 1-piece with no assembly required.
 4. Hairline cracks may develop over time. These are not structural failures, but inherent characteristics of the material itself.
 5. Air pockets are a common occurrence in precast products. The frequency and size of air pockets are variable and to be expected, especially on vertical surfaces.
 6. Concrete corners and edges will chip if not handled according to guidelines. Patch kits are available but may or may not blend and can be variable.
 7. There is a level of care and maintenance associated with your product and is the responsibility of the end user. Choosing the right sealer can help minimize those costs.

WEIGHT: 2450 LBS
 TEXTURE:
 COLOR:
 SEALER:

ODC Medium Gray

Light Sandblast

Integrally Cast Anti-Skateboard System

* Wheelchair Accessibility available at both ends of table to meet A.D.A. Guidelines

OUTDOOR CREATIONS INC.
 2270 Barney Street
 Anderson, CA 96007
 (530) 365-6106
 FAX (530) 365-5129

MODEL #100FSK2E CONCRETE PICNIC TABLE DOUBLE SIDE ENTRANCE TABLE W/ANTI-SKATE BUMPS

OUTDOOR CREATIONS, INC. CUSTOMER APPROVAL x

SCALE: 1" = 32" DRAWN BY: MNC

MAN. TOL. +/- 1/4"

Integrally Cast Anti-Skateboard System

NOTES:
 1. Concrete mix design to include a mixture of Portland Cement, water, coarse and fine aggregates, pure mineral oxide coloring agents (when applicable) to yield a minimum compressive strength of 5000 psi.
 2. Final product shall be reinforced with #4 and #5 rebar grid.
 3. Product is cast in 1-piece with no assembly required.
 4. Hairline cracks may develop over time. These are not structural failures, but inherent characteristics of the material itself.
 5. Air pockets are a common occurrence in precast products. The frequency and size of air pockets are variable and to be expected, especially on vertical surfaces.
 6. Concrete corners and edges will chip if not handled according to guidelines. Patch kits are available but may or may not blend and can be variable.
 7. There is a level of care and maintenance associated with your product and is the responsibility of the end user. Choosing the right sealer can help minimize those costs.

WEIGHT: 2350 LBS
 TEXTURE:
 COLOR:
 SEALER:

ODC Medium Gray

Light Sandblast

Integrally Cast Anti-Skateboard System

1 BENCH
 OUTDOOR CREATIONS

2 PICNIC TABLE
 OUTDOOR CREATIONS

3 PICNIC TABLE - ADA
 OUTDOOR CREATIONS

MODEL #510 CONCRETE WASTE RECEPTACLE - 25 GALLON ROUND

OUTDOOR CREATIONS, INC. CUSTOMER APPROVAL x

SCALE: 1" = 24" DRAWN BY: MNC

Lid made from 14 gauge steel powder coated bronze with 10" trash opening. Attached to casting with 1/8" x 24" stainless steel aircraft security cable

25 gallon plastic liner included

Recommended to secure trash receptacle to concrete slab with construction epoxy.

2" dia drain hole

NOTES:
 1. Concrete mix design to include a mixture of Portland Cement, water, coarse and fine aggregates, pure mineral oxide coloring agents (when applicable) to yield a minimum compressive strength of 5000 psi.
 2. Final product shall be reinforced with #4 and #5 rebar grid.
 3. Product is cast in 1-piece with no assembly required.
 4. Hairline cracks may develop over time. These are not structural failures, but inherent characteristics of the material itself.
 5. Air pockets are a common occurrence in precast products. The frequency and size of air pockets are variable and to be expected, especially on vertical surfaces.
 6. Concrete corners and edges will chip if not handled according to guidelines. Patch kits are available but may or may not blend and can be variable.
 7. There is a level of care and maintenance associated with your product and is the responsibility of the end user. Choosing the right sealer can help minimize those costs.

WEIGHT: 1000 LBS
 TEXTURE:
 COLOR:
 SEALER:

ODC Medium Gray

Light Sandblast

OUTDOOR CREATIONS INC.
 2270 Barney Street
 Anderson, CA 96007
 (530) 365-6106
 FAX (530) 365-5129

DOG WASTE STATION

OPTIONAL UTILITY SHELF - ADD IS TO MODEL NUMBER

NOTE: LOCAL SOIL CONDITIONS MAY REQUIRE A LARGER FOOTING

ALL DIMENSIONS IN INCHES

RJThomas Mfg. Co., Inc.
 P.O. Box 946
 Cherokee, IA 51012
 Specification Bulletin #RJCGR02

TITLE MODEL N-20 PARK GRILL WITH B2 BASE - SHOWN WITH OPTIONAL UTILITY SHELF

DRAWN BY: WWM
 DATE: 10-28-08
 DWG. NO.: AI-1403

COLOR: [Green swatch]

7 BIKE RACK
 MADRAX

COLOR: [Green swatch]

8 DRINKING FOUNTAIN W/BOTTLE FILLER AND PET FOUNTAIN
 MOST DEPENDABLE FOUNTAINS

GREEN ATTACHED PET FOUNTAIN TEMPLATE 10 NS

4 WASTE RECEPTACLE
 OUTDOOR CREATIONS

5 PET STATION
 ZERO WASTE USA

8 DRINKING FOUNTAIN W/BOTTLE FILLER AND PET FOUNTAIN
 MOST DEPENDABLE FOUNTAINS

<p>NO WORK SHALL BE DONE ON THIS SITE UNTIL BELOW AGENCY IS NOTIFIED OF INTENTION TO GRADE OR EXCAVATE.</p> <p>Underground Service Alert Call: TOLL FREE 811</p> <p>WWW.CALL811.COM TWO WORKING DAYS BEFORE YOU DIG</p>	<p>BASIS OF BEARING</p> <p>THE BASIS OF BEARINGS FOR THIS SURVEY IS THE CALIFORNIA STATE PLANE COORDINATE SYSTEM COE83, ZONE 6, BASED LOCALLY ON CONTROL STATIONS "TR45", "P478", AND "S400" NAD 83 (NRSR2011) EPOCH 2010.00 AS SHOWN HEREON. ALL BEARINGS SHOWN ON THIS MAP ARE GRID. QUOTED BEARINGS AND DISTANCES FROM REFERENCE MAPS OR DEEDS ARE, AS SHOWN PER THAT RECORD REFERENCE. ALL DISTANCES SHOWN ARE GROUND DISTANCES UNLESS SPECIFIED OTHERWISE. GRID DISTANCES MAY BE OBTAINED BY MULTIPLYING THE GROUND DISTANCE BY A COMBINATION FACTOR OF 0.99993579. CALCULATIONS ARE MADE AT 1"IP TAGGED "LS 5174", DOWN 0.2" IN WELL PER TRACT 36882, MB 454-07--39 WITH COORDINATES OF N: 227736.255000000, E: 628631.210000000 USING AN ELEVATION OF 1565.533</p>	<p>REVIEW BY CITY STAFF</p> <table border="1"> <tr> <th>OFFICE</th> <th>INITIAL</th> <th>DATE</th> <th>NO.</th> <th>DATE</th> <th>INITIALS</th> <th>E.O.R.</th> </tr> <tr> <td>ENGINEERING DIVISION MANAGER</td> <td></td> <td></td> <td></td> <td></td> <td></td> <td></td> </tr> <tr> <td>LAND DEVELOPMENT</td> <td></td> <td></td> <td></td> <td></td> <td></td> <td></td> </tr> <tr> <td>PLANNING</td> <td></td> <td></td> <td></td> <td></td> <td></td> <td></td> </tr> <tr> <td>TRANSPORTATION</td> <td></td> <td></td> <td></td> <td></td> <td></td> <td></td> </tr> <tr> <td>PARKS AND COMMUNITY SERVICES</td> <td></td> <td></td> <td></td> <td></td> <td></td> <td></td> </tr> <tr> <td>SPECIAL DISTRICTS</td> <td></td> <td></td> <td></td> <td></td> <td></td> <td></td> </tr> <tr> <td>STORM WATER MANAGEMENT PROGRAM</td> <td></td> <td></td> <td></td> <td></td> <td></td> <td></td> </tr> </table>	OFFICE	INITIAL	DATE	NO.	DATE	INITIALS	E.O.R.	ENGINEERING DIVISION MANAGER							LAND DEVELOPMENT							PLANNING							TRANSPORTATION							PARKS AND COMMUNITY SERVICES							SPECIAL DISTRICTS							STORM WATER MANAGEMENT PROGRAM							<p>REVISION</p> <table border="1"> <tr> <th>DESCRIPTION</th> <th>DATE</th> <th>APPR</th> </tr> <tr> <td></td> <td></td> <td></td> </tr> </table>	DESCRIPTION	DATE	APPR				<p>LANDSCAPE ARCHITECT OF RECORD'S SEAL</p> <p>REGISTERED LANDSCAPE ARCHITECT</p> <p>SHANNON P. KARLSON R.L.A. #6070 (EXP. 10/31/23)</p>	<p>bmla LANDSCAPE ARCHITECTURE</p> <p>310 NORTH JOY STREET CORONA, CA 92607 TEL: 951.207.1124 FAX: 951.207.6697</p> <p>PLANS PREPARED UNDER THE SUPERVISION OF:</p> <p>SHANNON P. KARLSON R.L.A. #6070 (EXP. 10/31/23)</p> <p>8/21/23 DATE</p>	<p>CITY OF MORENO VALLEY</p> <p>PUBLIC PARK IMPROVEMENT PLANS TRACT 38236 STELLA PONTE & BELLA SERA</p> <p>HARDSCAPE DETAILS</p>	<p>LHD-4</p> <p>SHEET 9 OF 23</p> <p>CITY ID No: ---</p>
	OFFICE	INITIAL	DATE	NO.	DATE	INITIALS	E.O.R.																																																														
ENGINEERING DIVISION MANAGER																																																																					
LAND DEVELOPMENT																																																																					
PLANNING																																																																					
TRANSPORTATION																																																																					
PARKS AND COMMUNITY SERVICES																																																																					
SPECIAL DISTRICTS																																																																					
STORM WATER MANAGEMENT PROGRAM																																																																					
DESCRIPTION	DATE	APPR																																																																			



PROJECT: _____
 LOCATION: _____
 BUILDING TYPE: RAM-24X34
 ROOF TYPE: MULTI-RIB

DRAWING LIST:

SHEET NUMBER	DRAWING DESCRIPTION
CS	COVER SHEET
1	ARCHITECTURAL ELEVATIONS
2	STRUCTURAL FRAMING PLAN
3	COLUMN LAYOUT

FABRICATOR APPROVALS:
 CITY OF THUNDERBOLT APPROVED FABRICATOR #C08-2010
 CITY OF LOS ANGELES, CA APPROVED FABRICATOR #1596
 CITY OF RIVERSIDE, CA APPROVED FABRICATOR #SP06-0033
 CITY OF HOUSTON, TX APPROVED FABRICATOR #470
 CLARK COUNTY, NV APPROVED FABRICATOR #284
 STATE OF UTAH APPROVED FABRICATOR 02006-14

CERTIFICATES:
 MARIQUETE COUNTY CERTIFICATE OF COMPETENCY NO. 16-0813.16
 PSI (POWDER COATING INSTITUTE) 4000 CERTIFIED

MATERIALS:

DESCRIPTION	ASTM DESIGNATION
TUBE STEEL	A500 (GRADE B)
SCHEDULE PIPE	A53 (GRADE B)
RMT PIPE	A518
LIGHT GAUGE COLD FORMED	A1003 (GRADE 50)
STRUCTURAL STEEL PLATE	A36
ROOF PANELS (STEEL)	A553

GENERAL NOTES:
 UNLESS NOTED OTHERWISE, THIS STRUCTURE WAS DESIGNED TO ONLY SUPPORT WHAT IS SHOWN ON THESE DRAWINGS. POLYGON MUST BE CONTACTED IF ANYTHING ELSE IS TO BE ATTACHED TO THIS STRUCTURE (WALLS, COLUMN WRAPS, RAILINGS, ETC.) SO THE DESIGN OF THIS STRUCTURE CAN BE REVIEWED AND POSSIBLY REVISED.

UNLESS NOTED OTHERWISE, THIS STRUCTURE WAS DESIGNED ASSUMING A 2' SEPARATION BETWEEN ANY ADJACENT STRUCTURE WITH AN EAVE HEIGHT EQUAL TO OR GREATER THAN THE EAVE HEIGHT OF THIS STRUCTURE. IF THAT SEPARATION DOES NOT EXIST, POLYGON MUST BE CONTACTED SO THE DESIGN OF THIS STRUCTURE CAN BE REVIEWED AND POSSIBLY REVISED.

STRUCTURAL STEEL SHALL BE DETAILED, FABRICATED, AND ERECTED IN ACCORDANCE WITH THE LATEST EDITION OF THE AMERICAN INSTITUTE OF STEEL CONSTRUCTION (AISC) SPECIFICATION MANUAL.

NOTE: SHELTER IS A DEFERRED SUBMITTAL AND IS SHOWN FOR REFERENCE ONLY. CONTRACTOR TO BE RESPONSIBLE FOR PERMIT AND STRUCTURAL DOCUMENTS.

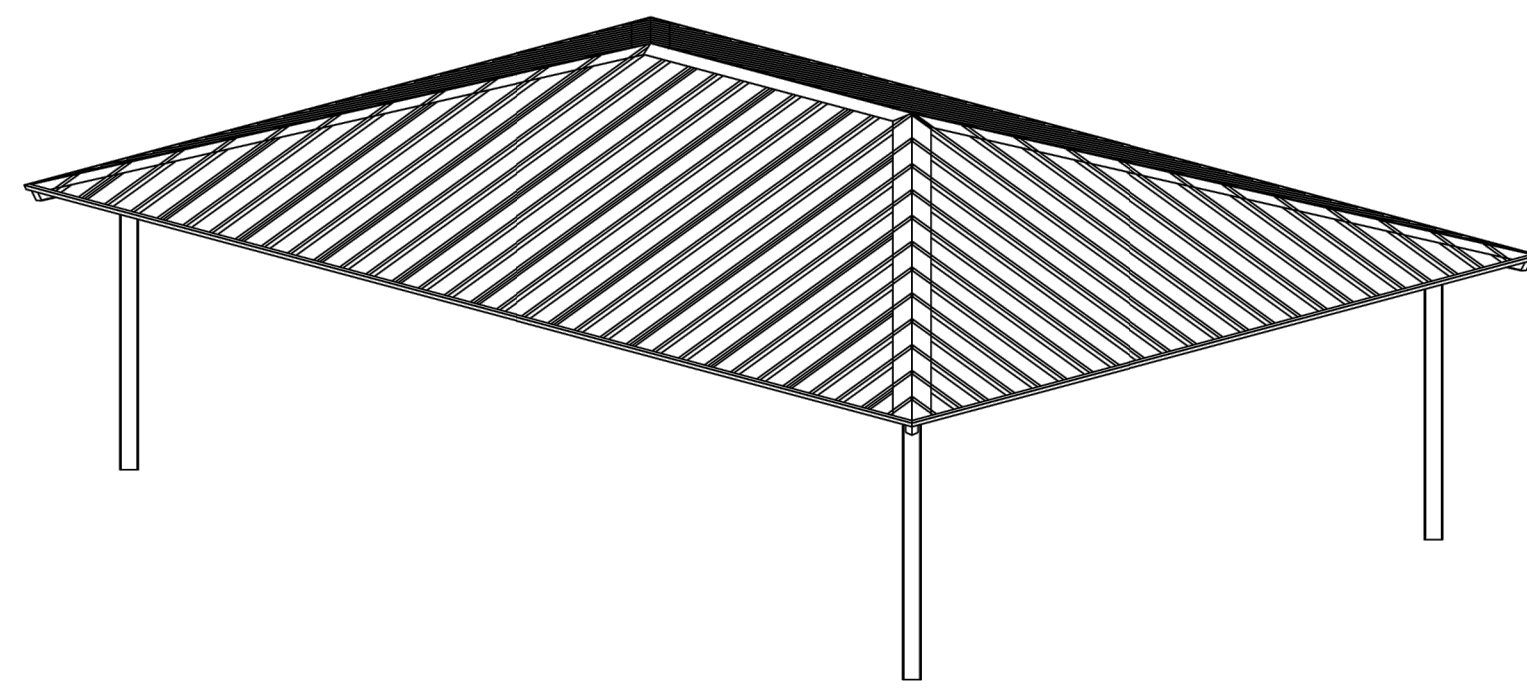

STOP!!
 NOT FOR CONSTRUCTION
 USE FOR PRELIMINARY PLANNING AND ESTIMATING ONLY

DRAWING: COVER SHEET
 SCALE: 1:55
 REV LEVEL: A
 SHEET: CS

poligon by PORTERCORP

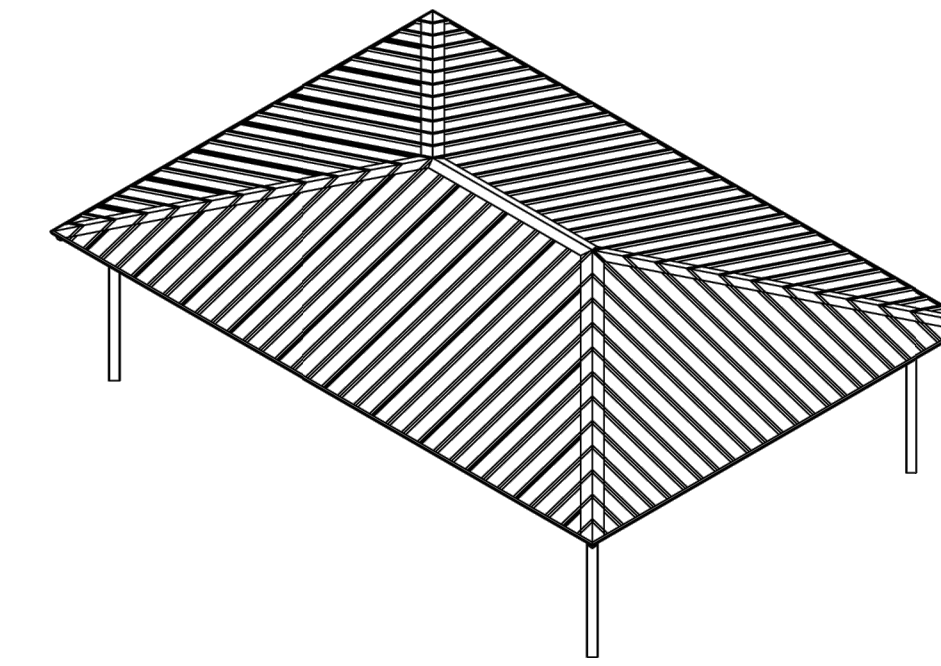
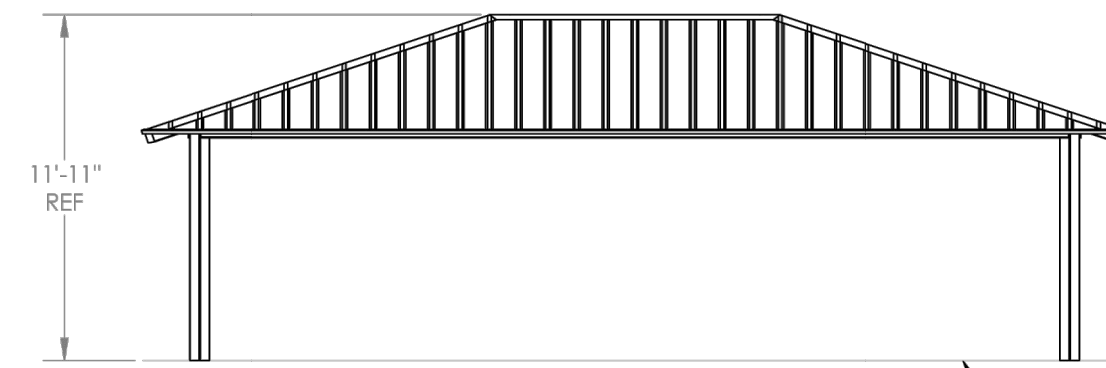
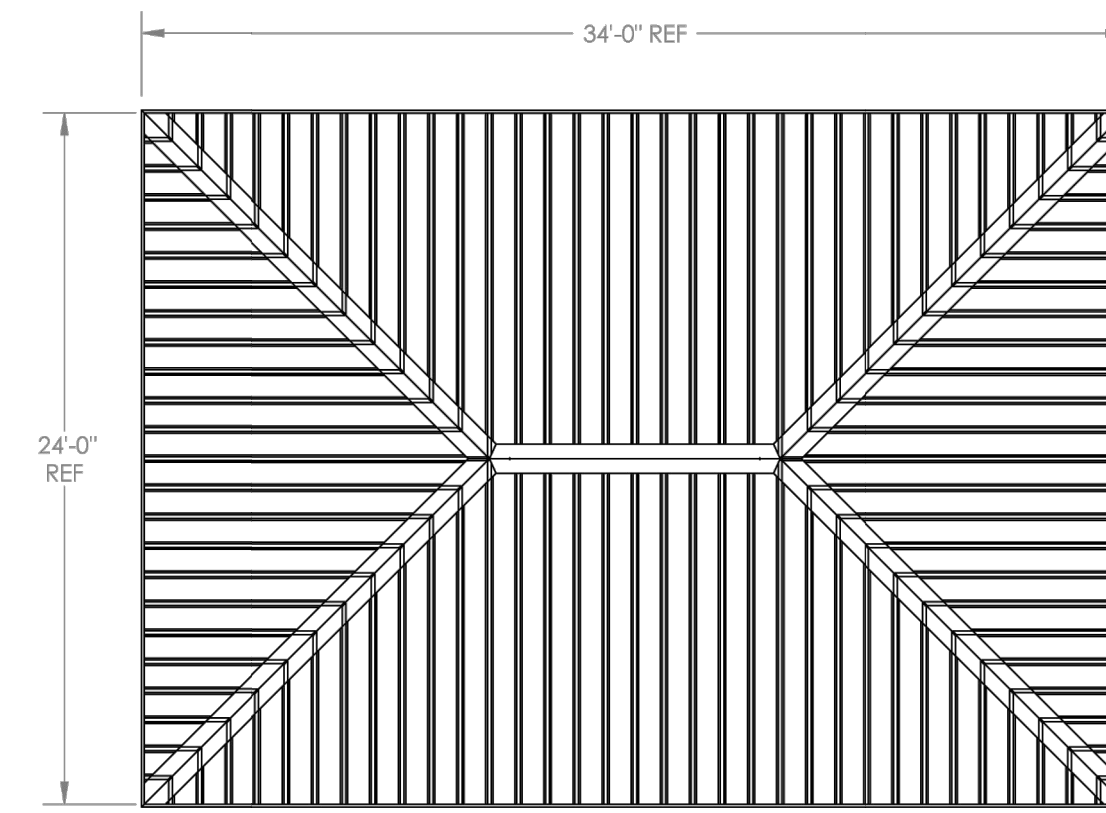

- GENERAL ROOF NOTES:**
- METAL ROOFING:
 - 24 GAUGE
 - GALVALUME COATED
 - KYNAR 500 PAINTED
 - TRIM COLOR MATCHES ROOF
 - SEE POLYGON.COM FOR COLOR OPTIONS

ROOF: EVERGREEN
 FRAME: SURREY BEIGE

STOP!!
 NOT FOR CONSTRUCTION
 USE FOR PRELIMINARY PLANNING AND ESTIMATING ONLY

DRAWING: ARCHITECTURAL ELEVATIONS
 SCALE: 1:70
 REV LEVEL: A
 SHEET: 1

poligon by PORTERCORP

FINISH GRADE MOUNTING VARIES BASED ON ENGINEERING REQUIREMENTS.

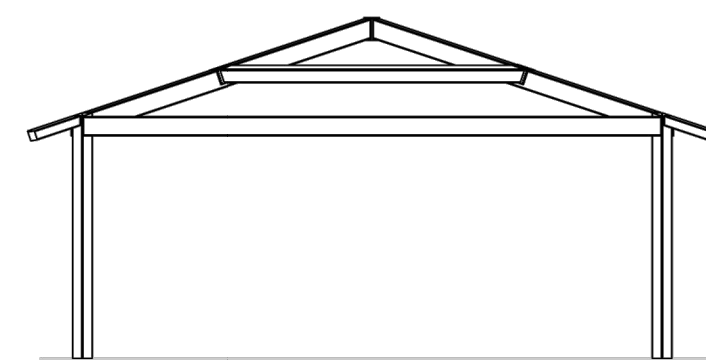
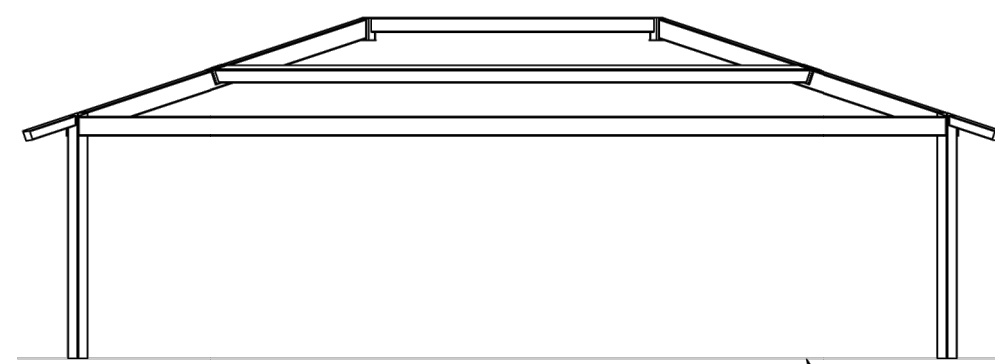
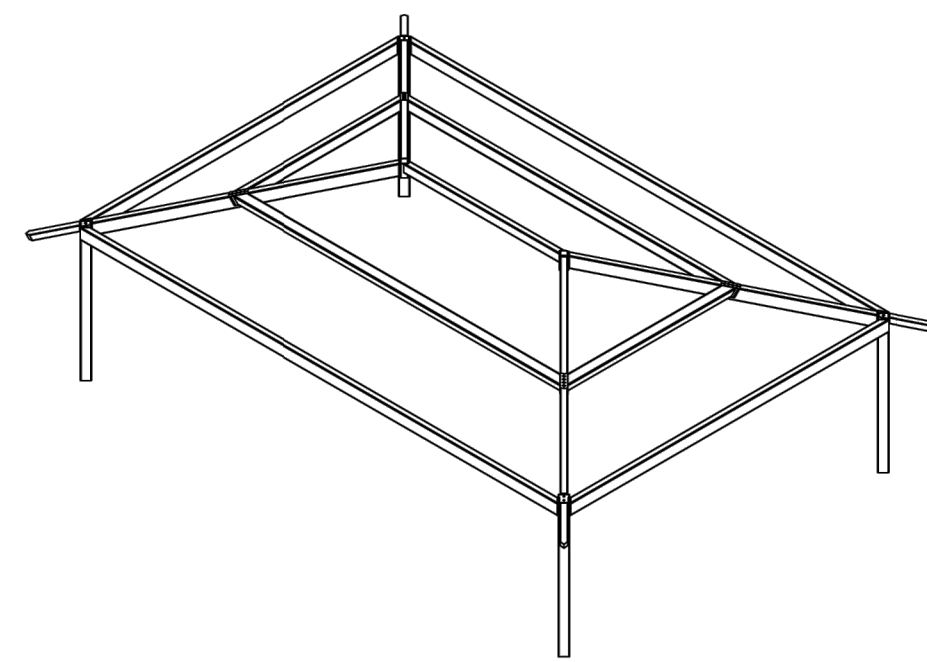
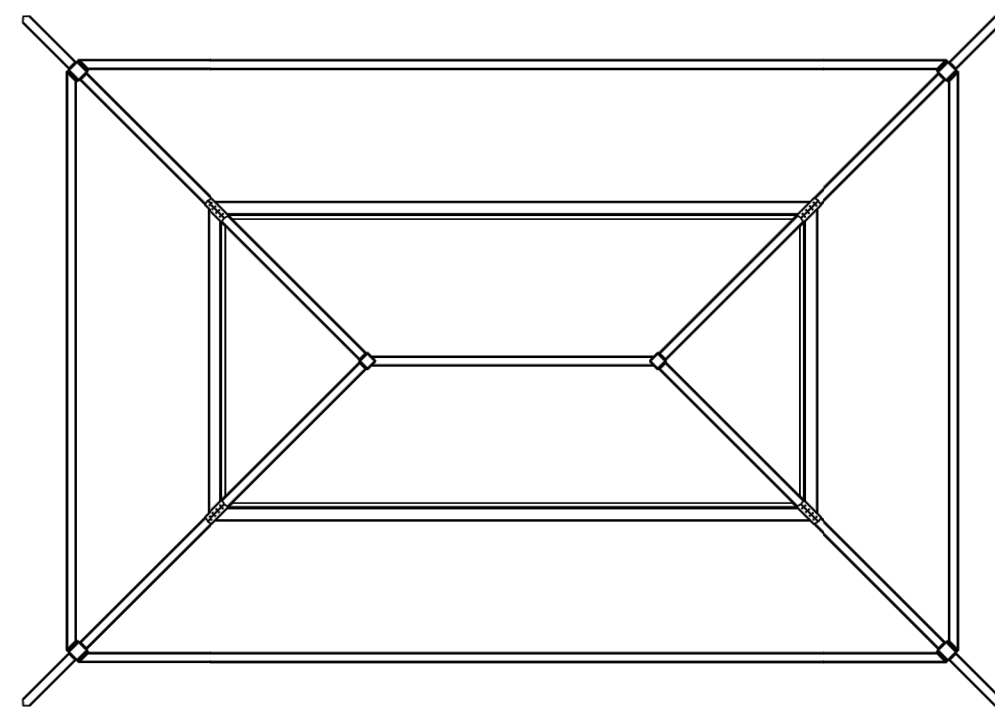

STOP!!
 NOT FOR CONSTRUCTION
 USE FOR PRELIMINARY PLANNING AND ESTIMATING ONLY

DRAWING: STRUCTURAL FRAMING PLAN
 SCALE: 1:70
 REV LEVEL: A
 SHEET: 2

poligon by PORTERCORP

FINISH GRADE MOUNTING VARIES BASED ON ENGINEERING REQUIREMENTS.

- BASEPLATE NOTES:**
- POLYGON ENGINEERING WILL DETERMINE REQUIRED BASEPLATE DESIGN AFTER ENGINEERING PACKAGE IS ORDERED.
 - CUSTOMER MAY SUGGEST PREFERRED BASEPLATE DESIGN.

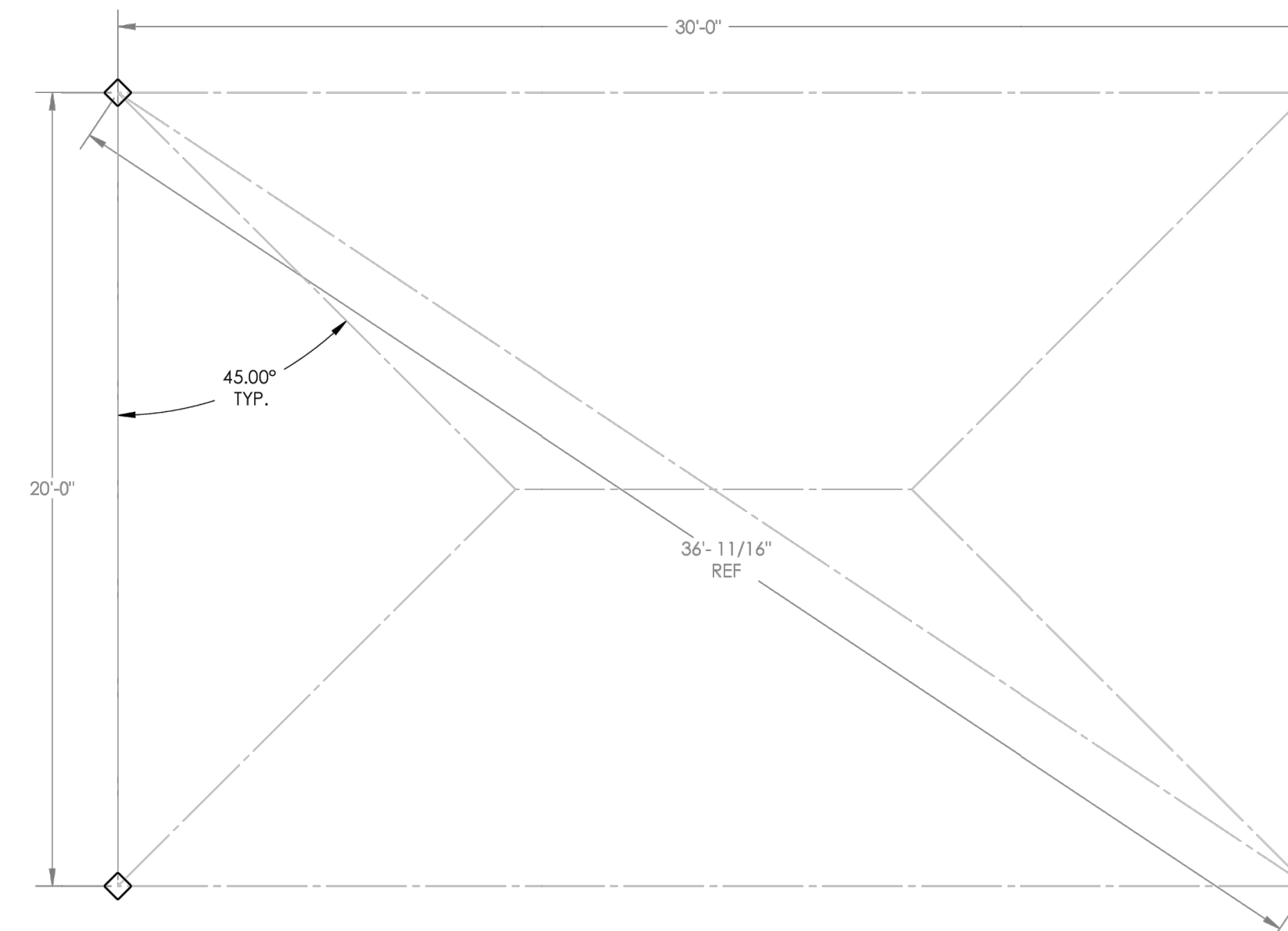

STOP!!
 NOT FOR CONSTRUCTION
 USE FOR PRELIMINARY PLANNING AND ESTIMATING ONLY

DRAWING: COLUMN LAYOUT
 SCALE: 1:40
 REV LEVEL: A
 SHEET: 3

poligon by PORTERCORP

NO WORK SHALL BE DONE ON THIS SITE UNTIL BELOW AGENCY IS NOTIFIED OF INTENTION TO GRADE OR EXCAVATE.
 Underground Service Alert
 Call: TOLL FREE 811
 WWW.CALL811.COM
 TWO WORKING DAYS BEFORE YOU DIG

BASIS OF BEARING
 THE BASIS OF BEARINGS FOR THIS SURVEY IS THE CALIFORNIA STATE PLANE COORDINATE SYSTEM CCS83, ZONE 6, BASED LOCALLY ON CONTROL STATIONS "TR45", "TR47", AND "SBC0" NAD 83 (NRSR2011) EPOCH 2010.00 AS SHOWN HEREON. ALL BEARINGS SHOWN ON THIS MAP ARE GRID. QUOTED BEARINGS AND DISTANCES FROM REFERENCE MAPS OR DEEDS ARE, AS SHOWN PER THAT RECORD REFERENCE. ALL DISTANCES SHOWN ARE GROUND DISTANCES UNLESS SPECIFIED OTHERWISE. GRID DISTANCES MAY BE OBTAINED BY MULTIPLYING THE GROUND DISTANCE BY A COMBINATION FACTOR OF 0.99999579. CALCULATIONS ARE MADE AT 1"= TAGGED "LS 5174", DOWN 0.2' IN WELL PER TRACT 36882, MB 454-07--39 WITH COORDINATES OF: N: 227736.255000000, E: 6280431.210000000 USING AN ELEVATION OF 1565.533

REVIEW BY CITY STAFF		E.O.R.		REVISION	
OFFICE	INITIAL	DATE	NO.	DATE	INITIALS
ENGINEERING DIVISION MANAGER					
LAND DEVELOPMENT					
PLANNING					
TRANSPORTATION					
PARKS AND COMMUNITY SERVICES					
SPECIAL DISTRICTS					
STORM WATER MANAGEMENT PROGRAM					

LANDSCAPE ARCHITECT OF RECORD'S SEAL
 REGISTERED LANDSCAPE ARCHITECT
 SHANNON P. KARLSON
 10/31/23
 EXP. DATE 8/21/23
 DATE

bmla
 LANDSCAPE ARCHITECTURE
 310 NORTH JOY STREET | CORONA, CA 92609
 TEL: 951.267.1124 | FAX: 951.267.6697

PLANS PREPARED UNDER THE SUPERVISION OF:
 SHANNON P. KARLSON
 R.L.A. #6070 (EXP. 10/31/23)
 DATE 8/21/23

CITY OF MORENO VALLEY
 PUBLIC PARK IMPROVEMENT PLANS
 TRACT 38236
 STELLA PONTE & BELLA SERA
 HARDSCAPE DETAILS

LHD-5
 SHEET 10 OF 23
 CITY ID No: ---

Triple Bars

FSW210



Street workout is a physical activity that symbolizes the freedom of movement and encourages socializing. It is a combination of athletics, calisthenics and other sports, and mostly performed in the public space. A Parallel Bar can be found on every street workout area to train the upper body and core stability. This triple parallel bar is 4' 7" high, enough to

perform dips with extended legs. The rounded corners make it easy to swing your legs across the Parallel Bars, making it safe to try new tricks without the risk of injuries.

KOMPAN
Let's play

Item no. FSW21001-0901

General Product Information	
Dimensions LxWxH	6'5"x3'10"x4'7"
Age group	13+
Play capacity (users)	2
Color options	

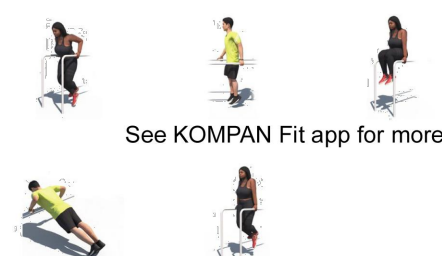

See KOMPAN Fit app for more



Data is subject to change without prior notice.

1 / 8/16/2022

Suspension Trainer. Core Twist. Mag. Bells Link

FAZ20401



The two Core Twist poles rotate 360° clockwise and counterclockwise with a resistance that can be determined by speed of movement. The Core Twist offers everyone a complete functional workout aimed at increasing overall strength and core stability. An innovative magnetic braking system in the Magnetic Bells allow the user to increase the resistance

by increasing the speed of movement. The patented system also functions as brake when someone drops the magnetic bells and will reduce the impact significantly. With the suspension trainer everyone can workout at their own level due to the scalable resistance. The intensity of each exercise can be determined simply by adjusting the body

position to add more or less resistance.

KOMPAN
Let's play

Item no. FAZ20401-0900

General Product Information	
Dimensions LxWxH	34'5"x3'6"x11'11"
Age group	13+
Play capacity (users)	9
Color options	

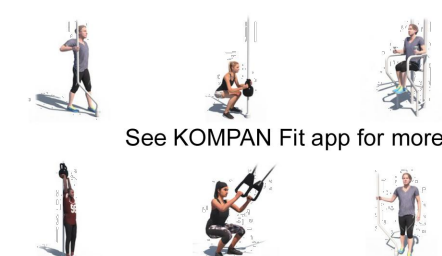

See KOMPAN Fit app for more



Data is subject to change without prior notice.

1 / 02/17/2023

Pull Up Station

FSW208

KOMPAN
Let's play

Item no. FSW20801-0901

General Product Information	
Dimensions LxWxH	9'12"x0'5"x8'10"
Age group	13+
Play capacity (users)	2
Color options	

COLOR:



The vertical ladder can be used as a wall, to influence difficulty levels of various exercises such as hand stand push ups, Bulgarian split squats and push ups. Additionally the vertical ladder is perfect for stretching and offers a step up for reaching the pull up bar. The Pull Up Bar is made from solid steel and has a diameter of Ø32 mm. An ideal size for both men and

women to have a good grip.



See KOMPAN Fit app for more



Data is subject to change without prior notice.

1 / 02/28/2023

Pull Up Bars

FAZ103

KOMPAN
Let's play

Item no. FAZ10300-0900

General Product Information	
Dimensions LxWxH	13'10"x6'11"x11'11"
Age group	13+
Play capacity (users)	3
Color options	

COLOR:



The large shaped structures will make people curious and invite them to do a workout using the pull up bars, an item most people will recognise from indoor fitness. For inspiration and guidance they can look at signs which display the 14 basic exercises and link to the KOMPAN Sport & Fitness App. Pull ups are an essential part of a Cross Training workout, a

very effective form of exercise that combines the best activities of various sports, resulting in a diverse and complete training sessions. The Pull Up bar offers a range of scalable exercises, featuring multiple handles, i.e. rotating gym rings, balls and bars with varying diameters. By placing the feet on the horizontal bars beginners can decrease their bodyweight

during pull ups and work their way up to advanced training.

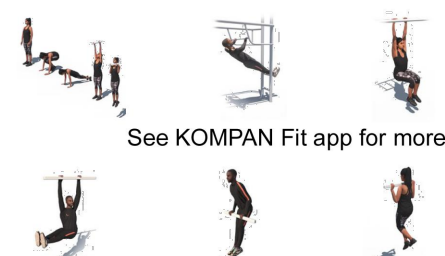

See KOMPAN Fit app for more



Data is subject to change without prior notice.

1 / 02/28/2023

Sit Up Bench

FSW203

KOMPAN
Let's play

Item no. FSW20300-0901

General Product Information	
Dimensions LxWxH	153x88x81 cm
Age group	13+
Play capacity (users)	1
Colour options	

COLOR:



The Bench provides perfect training for the core and lower back muscles by doing exercises such as leg lifts and sit ups. Easy grips are created to make sure anyone can do the exercise in a correct way. The durable Etogrip® surfacing offers perfect grip, allowing the bench to be used as a jump box for performing various step and jump exercises

under all weather conditions. The Bench has a clear instruction sign showing the basic exercise and a QR code. By using the QR code users can connect to the KOMPAN fitness App, where they will find multiple exercises and workouts at every level.



See KOMPAN Fit app for more



Data is subject to change without prior notice.

1 / 02/24/2023

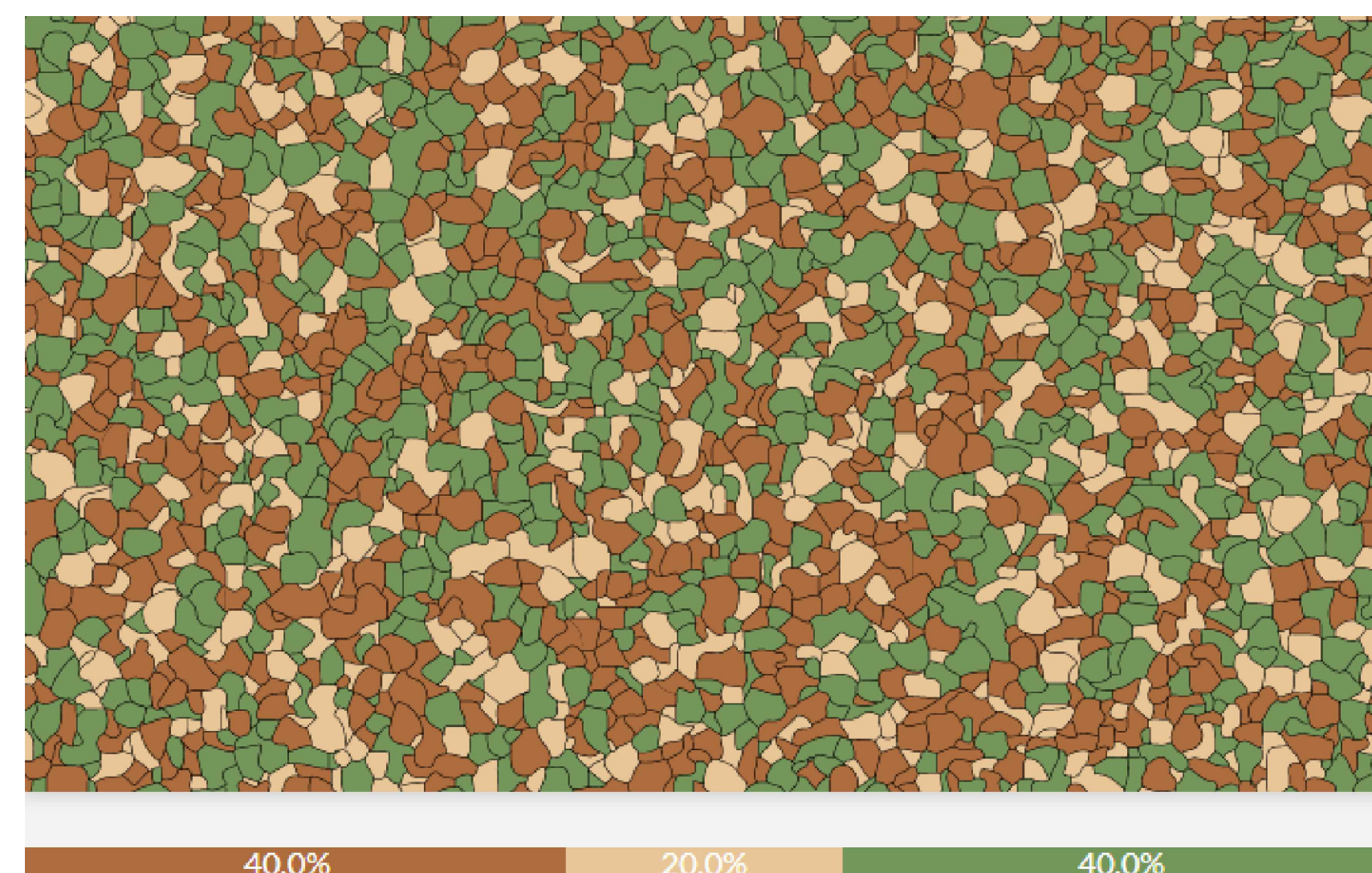

RUBBERIZED SURFACING COLOR SELECTION (SEE SHEET LHL-1)

<p>NO WORK SHALL BE DONE ON THIS SITE UNTIL BELOW AGENCY IS NOTIFIED OF INTENTION TO GRADE OR EXCAVATE.</p> <p>Underground Service Alert Call: TOLL FREE 811</p> <p>WWW.CALL811.COM TWO WORKING DAYS BEFORE YOU DIG</p>	<p>BASIS OF BEARING</p> <p>THE BASIS OF BEARINGS FOR THIS SURVEY IS THE CALIFORNIA STATE PLANE COORDINATE SYSTEM CCS83, ZONE 6, BASED LOCALLY ON CONTROL STATIONS "TRAC", "PA78", AND "SBOC" NAD 83 (NRSR2011) EPOCH 2010.00 AS SHOWN HEREON. ALL BEARINGS SHOWN ON THIS MAP ARE GRID. QUOTED BEARINGS AND DISTANCES FROM REFERENCE MAPS OR DEEDS ARE, AS SHOWN PER THAT RECORD REFERENCE. ALL DISTANCES SHOWN ARE GROUND DISTANCES UNLESS SPECIFIED OTHERWISE. GRID DISTANCES MAY BE OBTAINED BY MULTIPLYING THE GROUND DISTANCE BY A COMBINATION FACTOR OF 0.999993579. CALCULATIONS ARE MADE AT TYP TAGGED "LS 5174", DOWN 0.2' IN WELL PER TRACT 36882, MB 454/07-39 WITH COORDINATES OF: N: 227736.255000000, E: 6280431.21000000 USING AN ELEVATION OF 1665.533</p>	<p>REVIEW BY CITY STAFF</p> <table border="1"> <tr> <th>OFFICE</th> <th>INITIAL</th> <th>DATE</th> <th>NO.</th> <th>DATE</th> <th>INITIALS</th> <th>E.O.R.</th> <th>REVISION</th> <th>DESCRIPTION</th> <th>DATE</th> <th>APPR</th> </tr> <tr> <td>ENGINEERING DIVISION MANAGER</td> <td></td> <td></td> <td></td> <td></td> <td></td> <td></td> <td></td> <td></td> <td></td> <td></td> </tr> <tr> <td>LAND DEVELOPMENT</td> <td></td> <td></td> <td></td> <td></td> <td></td> <td></td> <td></td> <td></td> <td></td> <td></td> </tr> <tr> <td>PLANNING</td> <td></td> <td></td> <td></td> <td></td> <td></td> <td></td> <td></td> <td></td> <td></td> <td></td> </tr> <tr> <td>TRANSPORTATION</td> <td></td> <td></td> <td></td> <td></td> <td></td> <td></td> <td></td> <td></td> <td></td> <td></td> </tr> <tr> <td>PARKS AND COMMUNITY SERVICES</td> <td></td> <td></td> <td></td> <td></td> <td></td> <td></td> <td></td> <td></td> <td></td> <td></td> </tr> <tr> <td>SPECIAL DISTRICTS</td> <td></td> <td></td> <td></td> <td></td> <td></td> <td></td> <td></td> <td></td> <td></td> <td></td> </tr> <tr> <td>STORM WATER MANAGEMENT PROGRAM</td> <td></td> <td></td> <td></td> <td></td> <td></td> <td></td> <td></td> <td></td> <td></td> <td></td> </tr> </table>	OFFICE	INITIAL	DATE	NO.	DATE	INITIALS	E.O.R.	REVISION	DESCRIPTION	DATE	APPR	ENGINEERING DIVISION MANAGER											LAND DEVELOPMENT											PLANNING											TRANSPORTATION											PARKS AND COMMUNITY SERVICES											SPECIAL DISTRICTS											STORM WATER MANAGEMENT PROGRAM											<p>LANDSCAPE ARCHITECT OF RECORD'S SEAL</p> <p>bmla LANDSCAPE ARCHITECTURE</p> <p>310 NORTH JOY STREET CORONA, CA 92620 TEL: 951.267.1124 FAX: 951.267.6697</p> <p>PLANS PREPARED UNDER THE SUPERVISION OF:</p> <p><i>Shannon P. Karlson</i> SHANNON P. KARLSON R.L.A. #6070 (EXP. 10/31/23)</p> <p>8/21/23 DATE</p>	<p>CITY OF MORENO VALLEY</p> <p>PUBLIC PARK IMPROVEMENT PLANS TRACT 38236 STELLA PONTE & BELLA SERA</p> <p>HARDSCAPE DETAILS</p>	<p>LHD-6</p> <p>SHEET 11 OF 23</p> <p>CITY ID No ---</p>
	OFFICE	INITIAL	DATE	NO.	DATE	INITIALS	E.O.R.	REVISION	DESCRIPTION	DATE	APPR																																																																																		
ENGINEERING DIVISION MANAGER																																																																																													
LAND DEVELOPMENT																																																																																													
PLANNING																																																																																													
TRANSPORTATION																																																																																													
PARKS AND COMMUNITY SERVICES																																																																																													
SPECIAL DISTRICTS																																																																																													
STORM WATER MANAGEMENT PROGRAM																																																																																													

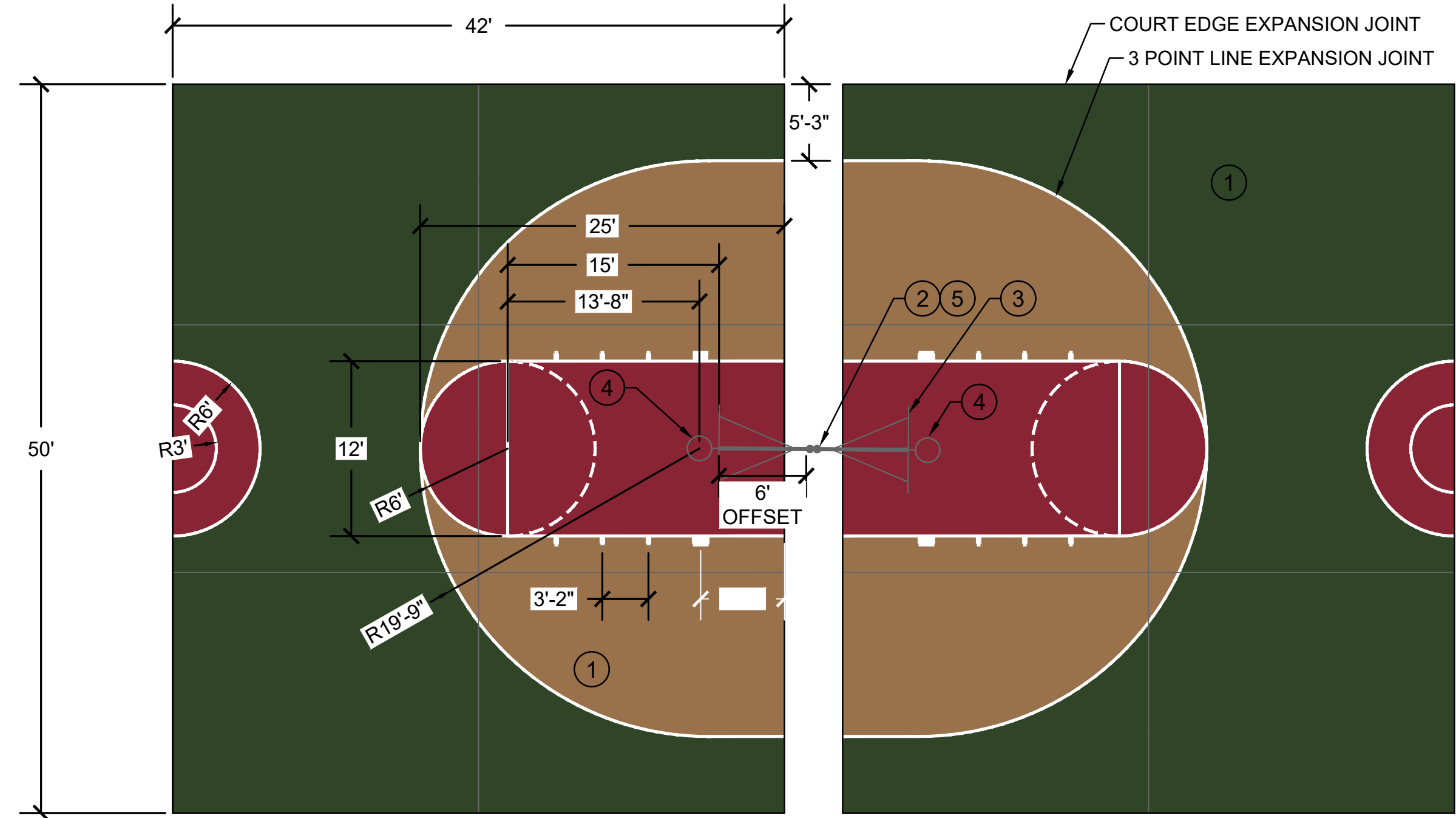

- ① PLEXIPAVE ON CONCRETE: COLOR PER HARDSCAPE LEGEND. APPLY PER MANUFACTURERS SPECIFICATIONS.
- ② BASKETBALL BACK-TO-BACK POST: REFER TO HARDSCAPE LEGEND FOR SPEC.
- ③ BASKETBALL BACKBOARD: REFER TO HARDSCAPE LEGEND FOR SPEC.
- ④ BASKETBALL NET & RIM: REFER TO HARDSCAPE LEGEND FOR SPEC.
- ⑤ BASKETBALL POST PAD: REFER TO HARDSCAPE LEGEND FOR SPEC.

	PLEXIPAVE COLOR: CALIFORNIA RED	683 SF
	PLEXIPAVE COLOR: DARK GREEN	2,446 SF
	PLEXIPAVE COLOR: SAHARA SAND	1,071 SF

① BASKETBALL HALF-COURT
1/8" = 1'-0"

- NOTES:**
- ALL COURT LINES TO BE 2" WIDE, WHITE (TYP.)
 - REFER TO BASKETBALL COURT AND GOALS DETAIL FOR CONCRETE DETAIL.
 - PLEXIPAVE IS A MULTI SURFACE PROCESS, REFER TO MANUFACTURER'S SPECIFICATIONS FOR INSTALLATION.
 - PLEXIPAVE SHALL BE INSTALLED BY AN AUTHORIZED PLEXIPAVE INSTALLER WITH A MINIMUM OF THREE PREVIOUS PLEXIPAVE INSTALLATIONS.
 - CONCRETE TO BE INSTALLED WITH A VAPOR BARRIER AND CURED FOR A MINIMUM OF 28 DAYS PRIOR TO APPLICATION OF PLEXIPAVE SURFACING SYSTEM.

BACK TO BACK GOOSENECK POSTS

MODEL #LA-12C066
6-5/8" O.D. WITH 6' OFFSET (750 LBS)

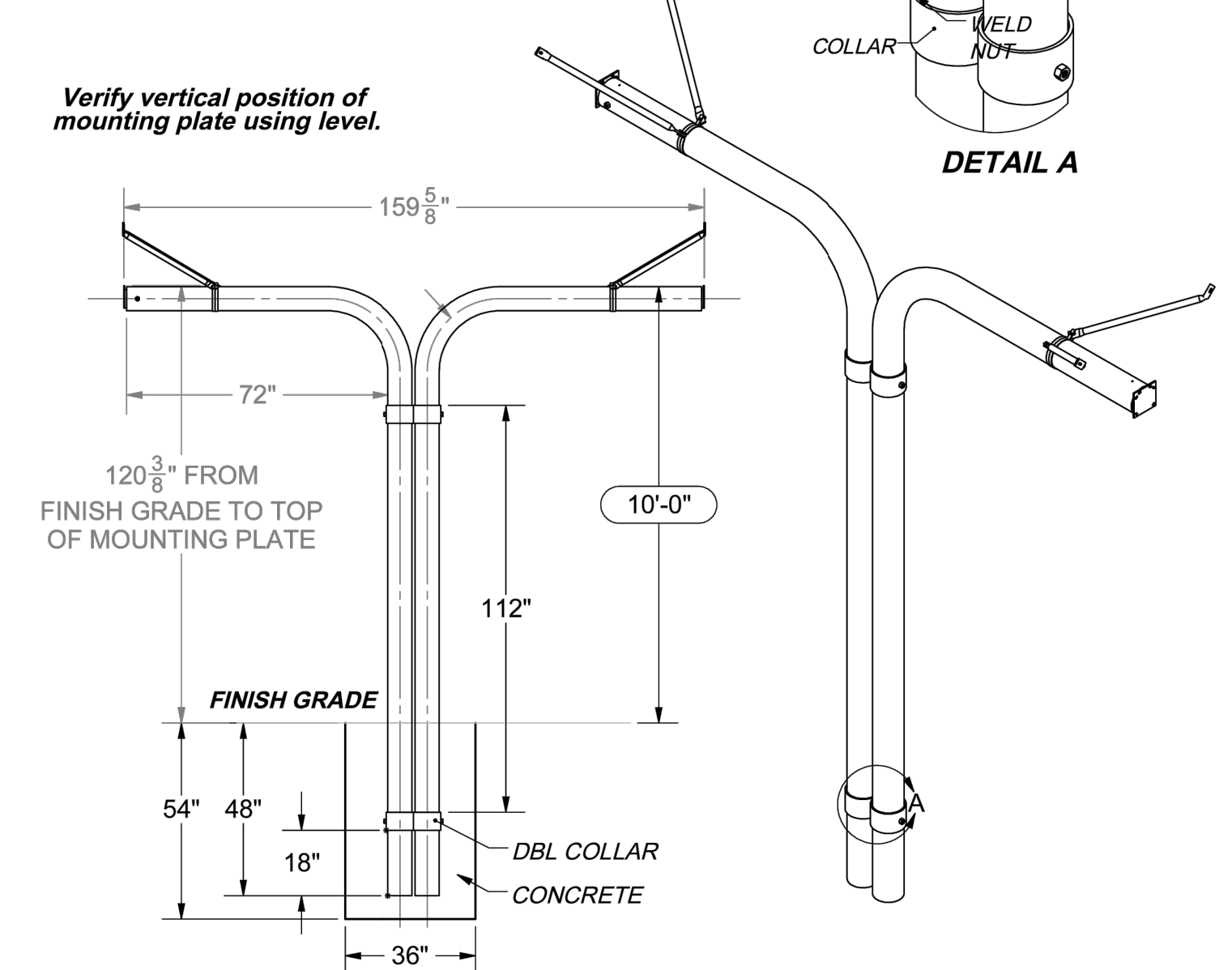

SPECIFICATIONS:

Material: Support post is a single length of 6-5/8" O.D. galvanized steel formed to provide a graceful 6 ft offset. Backboard mount is a 6-1/4" x 6-1/2" steel plate welded to the support post.

A pair of diagonal braces, 1" O.D. galvanized steel, is mounted between the backboard and the post. Braces bolt to the backboard and are secured to the post with a pair of steel clamps formed to fit the post diameter.

All welds are either treated with cold-galvanizing compound or prepared for powder coating, depending on finish selected. All hardware is zinc-coated for long rust-free service.

<p>www.STEELCRAFT.com 1-800-371-2438</p>	Date: 2/23/16	SPECIFICATION / INSTALLATION INSTRUCTIONS
	Rev: DH4/30/20	BACK TO BACK GOOSENECK POSTS
	Drawn: MT	MODEL NO.
	Sheet: 1 of 2	LA-12C066

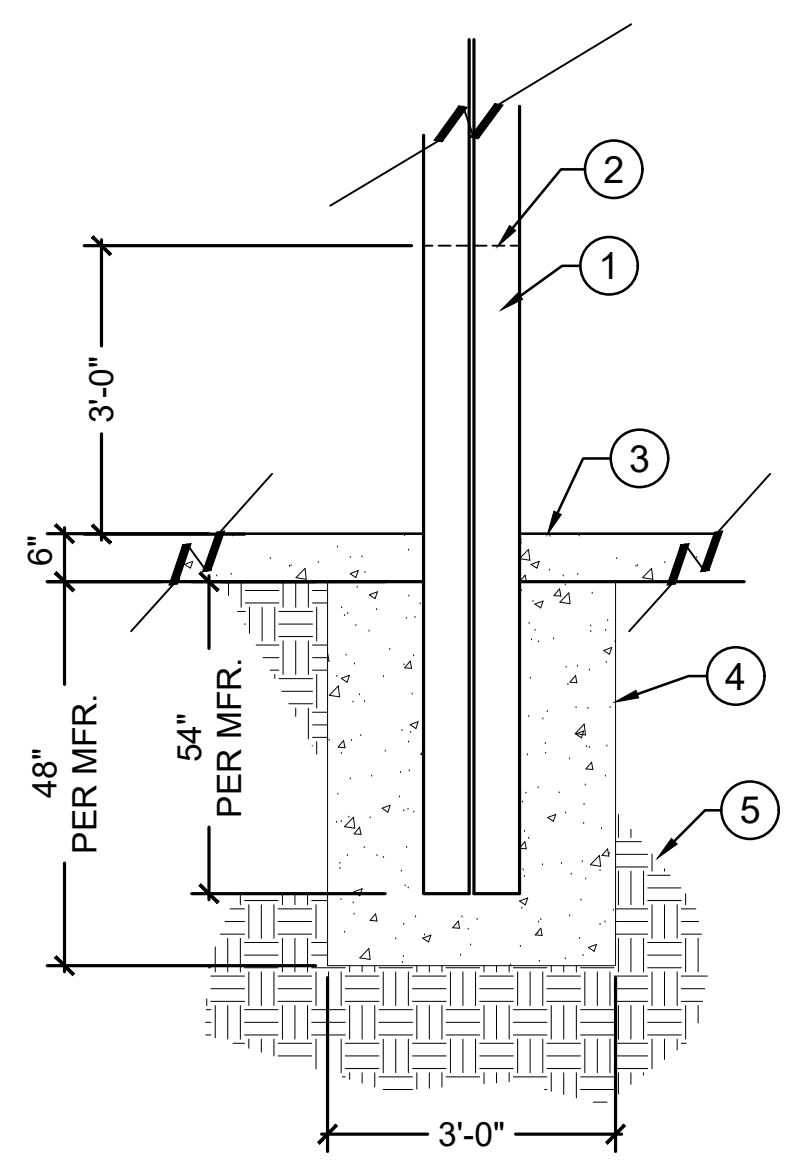

② BASKETBALL COURT AND COURT PAVEMENT DETAIL
1/2" = 1'-0"

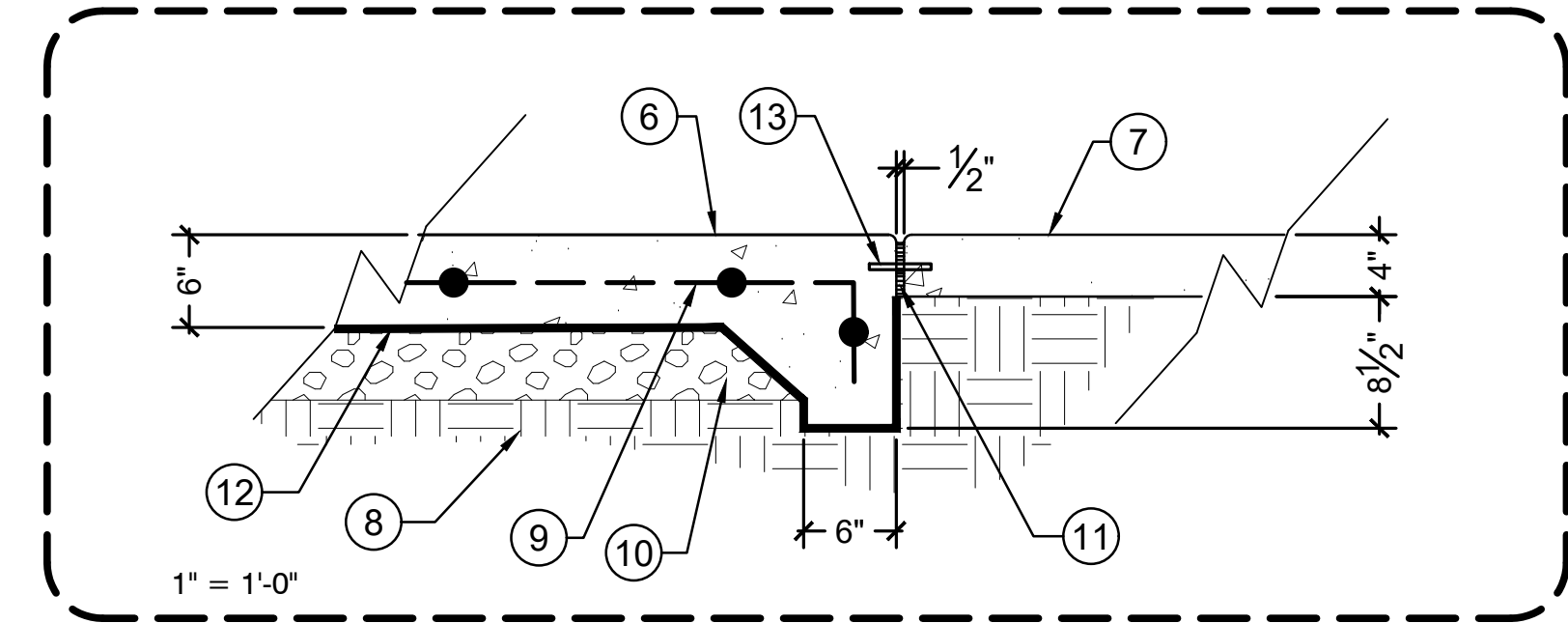

- ① 6-5/8" OD POST W/ 6' EXTENSION, SEE PLAN
- ② GROUT SOLID UP TO 3 FEET
- ③ PLAYING SURFACE - SEE PLAN
- ④ CONCRETE FOOTING PER MANUFACTURER'S RECOMMENDATION
- ⑤ 95% COMPACTED SUBGRADE, OR PER SOILS REPORT
- ⑥ 6" THICK 2500 PSI CONCRETE WITH LIGHT BROOM FINISH
- ⑦ CONCRETE WALK - SEE PLAN
- ⑧ 95% COMPACTED SUBGRADE, OR PER SOILS REPORT
- ⑨ #3 REBAR BOTH WAYS @ 18" O.C.
- ⑩ 4" COMPACTED CLASS II AGGREGATE BASE - COMPACTION TO BE 95% OR PER SOILS REPORT
- ⑪ BITUMINUS EXPANSION JOINT
- ⑫ CONTRACTOR TO INSTALL HUSKY-YELLOW GUARD 15 MIL VAPOR BARRIER UNDERNEATH BASKETBALL COURT
- ⑬ CONTINUOUS SLIP DOWEL @ 2'-0" O.C.

NO WORK SHALL BE DONE ON THIS SITE UNTIL BELOW AGENCY IS NOTIFIED OF INTENTION TO GRADE OR EXCAVATE.
Underground Service Alert
Call: TOLL FREE 811
www.call811.com
TWO WORKING DAYS BEFORE YOU DIG

BASIS OF BEARING
THE BASIS OF BEARINGS FOR THIS SURVEY IS THE CALIFORNIA STATE PLANE COORDINATE SYSTEM CCS83, ZONE 6, BASED LOCALLY ON CONTROL STATIONS "TR45", "TR47", AND "SBC1" NAD 83 (NAD83/2011) EPOCH 2010.00 AS SHOWN HEREON. ALL BEARINGS SHOWN ON THIS MAP ARE GRID. QUOTED BEARINGS AND DISTANCES FROM REFERENCE MAPS OR DEEDS ARE AS SHOWN PER THAT RECORD REFERENCE. ALL DISTANCES SHOWN ARE GROUND DISTANCES UNLESS SPECIFIED OTHERWISE. GRID DISTANCES MAY BE OBTAINED BY MULTIPLYING THE GROUND DISTANCE BY A COMBINATION FACTOR OF 0.999993579. CALCULATIONS ARE MADE AT TYP TAGGED "LS 5174", DOWN 0.2' IN WELL PER TRACT 36882, MB 454/07-09 WITH COORDINATES OF N: 227736.255000000, E: 6280431.21000000 USING AN ELEVATION OF 1665.533

REVIEW BY CITY STAFF		E.O.R.		REVISION	
OFFICE	INITIAL	DATE	NO.	DATE	INITIALS
ENGINEERING DIVISION MANAGER					
LAND DEVELOPMENT					
PLANNING					
TRANSPORTATION					
PARKS AND COMMUNITY SERVICES					
SPECIAL DISTRICTS					
STORM WATER MANAGEMENT PROGRAM					

LANDSCAPE ARCHITECT OF RECORD'S SEAL
REGISTERED LANDSCAPE ARCHITECT
SHANNON P. KARLSON
10/31/23
8/21/23
DATE

bmla
LANDSCAPE ARCHITECTURE
310 NORTH JOY STREET | CORONA, CA 92626
TEL: 951.267.1124 | FAX: 951.267.6697
PLANS PREPARED UNDER THE SUPERVISION OF:
SHANNON P. KARLSON
R.L.A. #6070 (EXP. 10/31/23)
8/21/23
DATE

CITY OF MORENO VALLEY
PUBLIC PARK IMPROVEMENT PLANS
TRACT 38236
STELLA PONTE & BELLA SERA
HARDSCAPE DETAILS
LHD-7
SHEET 12 OF 23
CITY ID No: ---

IRRIGATION NOTES:

- 1. THE CONTRACTOR SHALL NOTIFY THE LANDSCAPE ARCHITECT AND THE CITY'S INSPECTOR A MINIMUM OF 48 HOURS PRIOR TO STARTING CONSTRUCTION.
2. INSTALL ALL IRRIGATION COMPONENTS ACCORDING TO LOCAL CODES & ORDINANCES.
3. THE CONTRACTOR SHALL OBTAIN, COORDINATE AND PAY FOR ANY AND ALL PERMITS AND ALL INSPECTIONS AS REQUIRED.
...
11. INSTALL AIR/VACUUM RELIEF VALVES AT HIGHEST POINT OF DRIPLINE ZONE.
12. INSTALL AIR/VACUUM RELIEF VALVE IN AN EXHAUST HEADER OR THE LINE THAT RUNS PERPENDICULAR TO LATERAL LINES.
13. INSTALL MANUAL FLUSH POINT AT EACH END OF EACH SYSTEM ADJACENT TO THE HEADER.

Historical ET table with monthly data from Jan to Dec. Includes tables for Low Water Use Dripline Establishment, High Water Use Rotary Establishment, and High Water Use Turf Rotator Establishment, each with program definition and estimated watering days.

IRRIGATION SCHEDULE

Table with columns: SYMBOL, MANUFACTURER/MODEL/DESCRIPTION, PSI, DETAIL. Lists various irrigation components like Rain Bird R-VAN14, R-VAN18, R-VAN24, RWS-SOCK 1401, and SCH 40 BALL VALVE.

Table with columns: SYMBOL, MANUFACTURER/MODEL/DESCRIPTION, PSI, DETAIL. Lists various valves and sensors like NIBCO DRIP VALVE, NIBCO EFB-CP-PRS-D, and CALSENSE FLOW SENSOR.

WATER EFFICIENT LANDSCAPE WORKSHEET. Includes project info, conversion factor (0.62), hydrozone analysis table, and ETAF calculations (MAWA = 1,489,718).

IRRIGATION DETAIL NOTE: ALL IRRIGATION EQUIPMENT SHALL BE INSTALLED PER CITY OF MORENO VALLEY-PARKS AND COMMUNITY SERVICES DEVELOPMENT STANDARD DETAILS. Includes symbols for Valve Callout, Valve Number, Valve Flow, Hydrozone, and Valve Size.

Project information and approvals. Includes 'BASIS OF BEARING' section, 'REVIEW BY CITY STAFF' table, 'REVISION' table, 'LANDSCAPE ARCHITECT OF RECORD'S SEAL' for bmla, and 'CITY OF MORENO VALLEY' approval for Public Park Improvement Plans, Tract 38236.

Attachment: Tract 38236 Park Imp Plans (6417) - THE PUBLIC FACILITIES FEE CREDIT AGREEMENT WITH D.R. HORTON LOS ANGELES HOLDING COMPANY, INC.

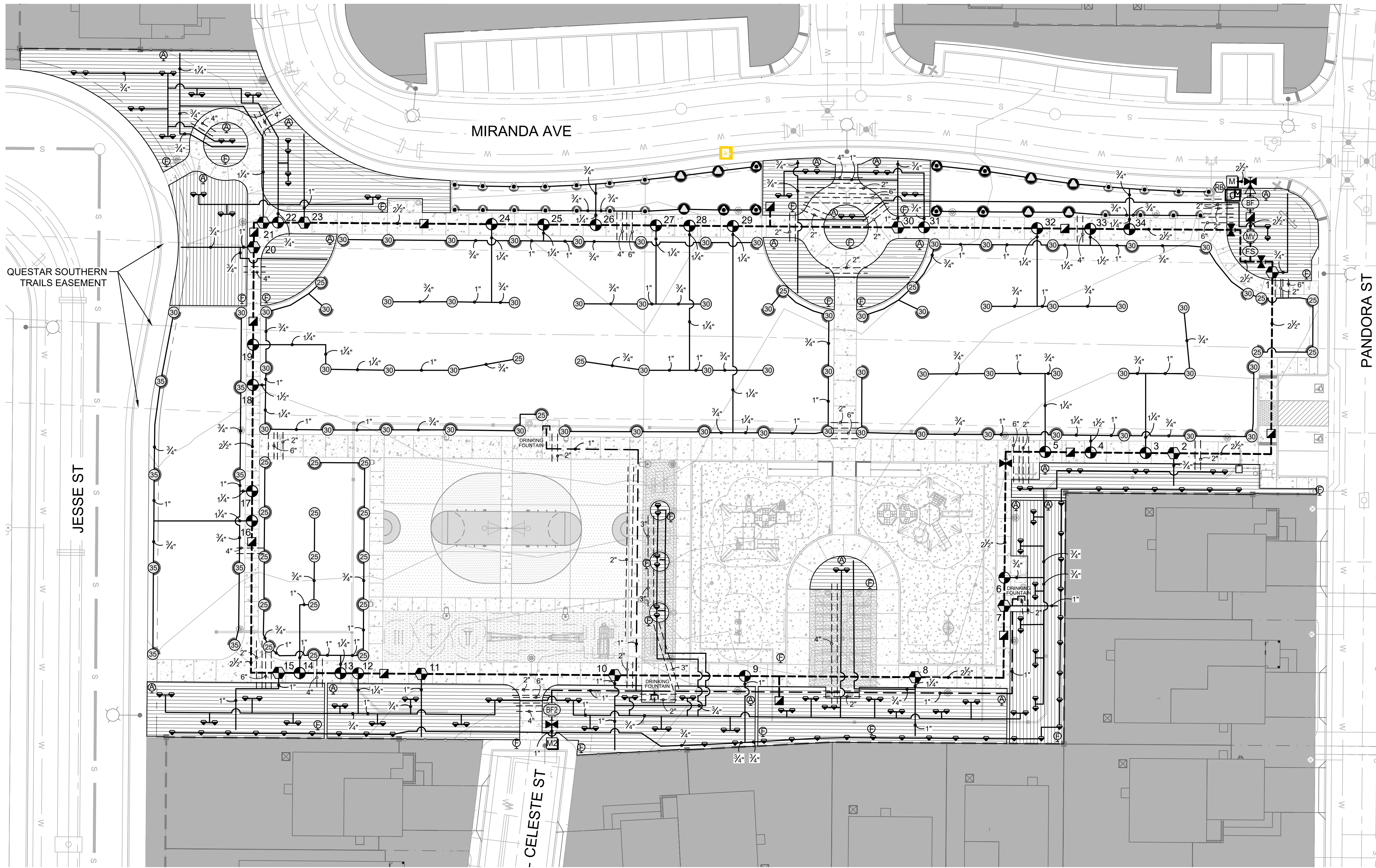

1	6.24	14	11.5	27	17.3
2	6.53	15	8.4	28	21.2
3	17.3	16	15.2	29	21.4
4	23.5	17	14.8	30	12.2
5	17.3	18	23.4	31	3
6	5	19	21.2	32	17.3
7	10.5	20	11.3	33	25.2
8	13.1	21	14.5	34	13.4
9	9.25	22	6		
10	11.7	23	8.37		
11	9.08	24	17.3		
12	13.5	25	21.5		
13	20.2	26	14.5		

CRITICAL ANALYSIS

Generated: 2023-08-02 14:48

P.O.C. NUMBER: 01
 Water Source Information:
 1-1/2" Potable water meter with 2" service line.
 Pressure Zone 1764. 86 PSI at elevation 1564.
 Verify in field and notify LA with any discrepancies.

FLOW AVAILABLE
 Water Meter Size: 1-1/2"
 Flow Available: 52.67 GPM

PRESSURE AVAILABLE
 Static Pressure at POC: 86 PSI
 Elevation Change: 5.00 ft
 Service Line Size: 2"
 Length of Service Line: 10 ft
 Pressure Available: 84 PSI

DESIGN ANALYSIS
 Maximum Multi-valve Flow: 50 GPM
 Flow Available at POC: 52.67 GPM
 Residual Flow Available: 2.67 GPM

Critical Station: 29
 Design Pressure: 45 PSI
 Friction Loss: 4.92 PSI
 Fittings Loss: 0.49 PSI
 Elevation Loss: 0 PSI
 Loss through Valve: 2.39 PSI
 Pressure Req. at Critical Station: 52.8 PSI
 Loss for Fittings: 0.13 PSI
 Loss for Main Line: 1.31 PSI
 Loss for POC to Valve Elevation: 0 PSI
 Loss for Backflow: 11.8 PSI
 Loss for Master Valve: 1.1 PSI
 Loss for Water Meter: 4.9 PSI
 Critical Station Pressure at POC: 72.0 PSI
 Pressure Available: 84 PSI
 Residual Pressure Available: 12.0 PSI

REFER TO SHEET LPL-1 FOR IRRIGATION SCHEDULES, WATER CALCULATIONS, AND NOTES

CONTROLLER ENCLOSURE NOTE:
 ELECTRICAL CONTRACTOR SHALL PROVIDE STRONGBOX METER ENCLOSURE AS NOTED ON ELECTRICAL PLANS. LANDSCAPE CONTRACTOR SHALL BE RESPONSIBLE FOR PROVIDING BACKBOARD ASSEMBLY TO FIT INTO EXISTING ELECTRICAL ENCLOSURE. COORDINATE WITH CALSENSE ON PRE-CONSTRUCTION MEETING AND CLOUD SERVICE IN THE FIELD.

HYDROZONE	WATER USE	IRRIGATION TYPE	PLANTING TYPE
1	LOW	INLINE DRIP	SHRUBS / GROUND COVER
2	MEDIUM	BUBBLER	TREES AND VINES
3	HIGH/SLA	ROTARY NOZZLE	TURF
4	HIGH/SLA	ROTOR	TURF

INDEX MAP NTS

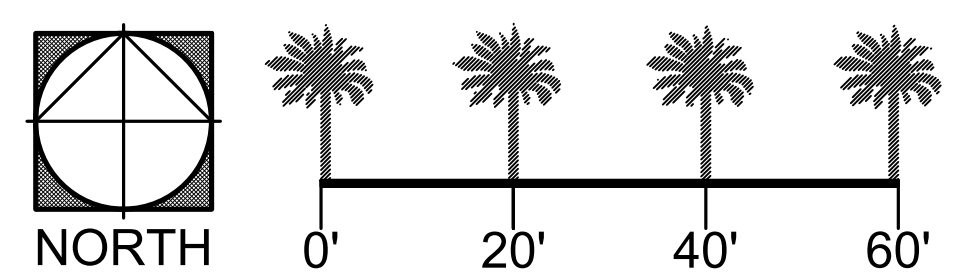
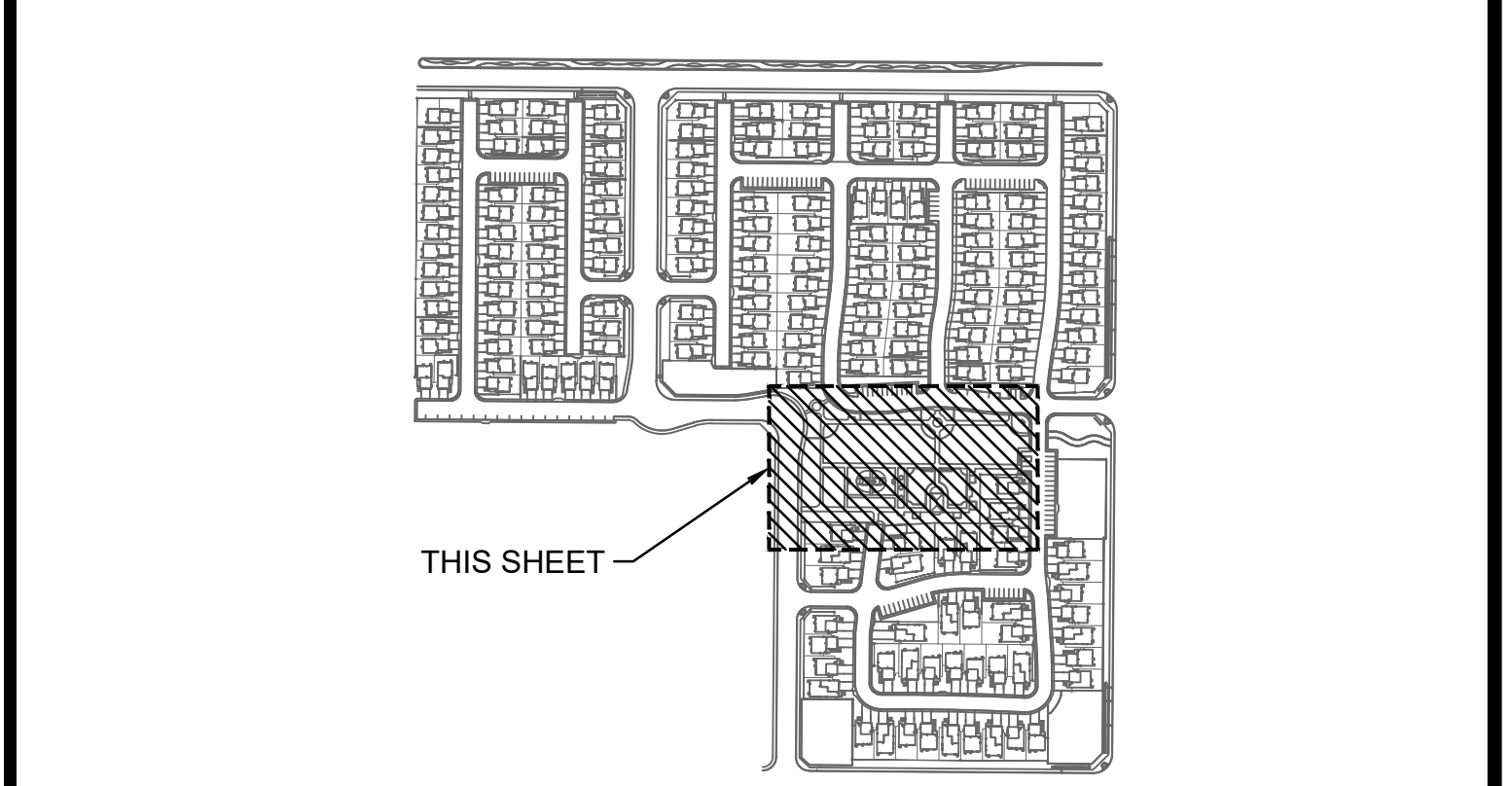

BASIS OF BEARING
 NO WORK SHALL BE DONE ON THIS SITE UNTIL BELOW AGENCY IS NOTIFIED OF INTENTION TO GRADE OR EXCAVATE.
 Underground Service Alert
 Call: TOLL FREE 811
 WWW.CALL811.COM
 TWO WORKING DAYS BEFORE YOU DIG

THE BASIS OF BEARINGS FOR THIS SURVEY IS THE CALIFORNIA STATE PLANE COORDINATE SYSTEM CCS83, ZONE 6, BASED LOCALLY ON CONTROL STATIONS "1482", "1478", AND "1503" NAD 83 (NRSR2011) EPOCH 2010.00 AS SHOWN HEREON. ALL BEARINGS SHOWN ON THIS MAP ARE GRID. QUOTED BEARINGS AND DISTANCES FROM REFERENCE MAPS OR DEEDS ARE, AS SHOWN PER THAT RECORD REFERENCE. ALL DISTANCES SHOWN ARE GROUND DISTANCES UNLESS SPECIFIED OTHERWISE. GRID DISTANCES MAY BE OBTAINED BY MULTIPLYING THE GROUND DISTANCE BY A COMBINATION FACTOR OF 0.999993579. CALCULATIONS ARE MADE AT TYP TAGGED "LS 5174", DOWN 0.2' IN WELL PER TRACT 36882, MB 454-07--39 WITH COORDINATES OF: N: 227736.255000000, E: 6286431.210000000 USING AN ELEVATION OF 1565.533

REVIEW BY CITY STAFF		E.O.R.		REVISION					
OFFICE	ENGINEERING DIVISION MANAGER	INITIAL	DATE	NO.	DATE	INITIALS	DESCRIPTION	DATE	APPR
LAND DEVELOPMENT									
PLANNING									
TRANSPORTATION									
PARKS AND COMMUNITY SERVICES									
SPECIAL DISTRICTS									
STORM WATER MANAGEMENT PROGRAM									

LANDSCAPE ARCHITECT OF RECORD'S SEAL

bmla
 LANDSCAPE ARCHITECTURE
 310 NORTH JOY STREET | CORONA, CA 92620
 TEL: 951.267.1294 | FAX: 951.267.6691

PLANS PREPARED UNDER THE SUPERVISION OF:

Shannon P. Karlson
 SHANNON P. KARLSON
 R.L.A. #6070 (EXP. 10/31/23)
 DATE: 8/21/23

CITY OF MORENO VALLEY

PUBLIC PARK IMPROVEMENT PLANS
 TRACT 38236
 STELLA PONTE & BELLA SERA

IRRIGATION PLAN

LI-1

SHEET 14 OF 23

CITY ID No: ---

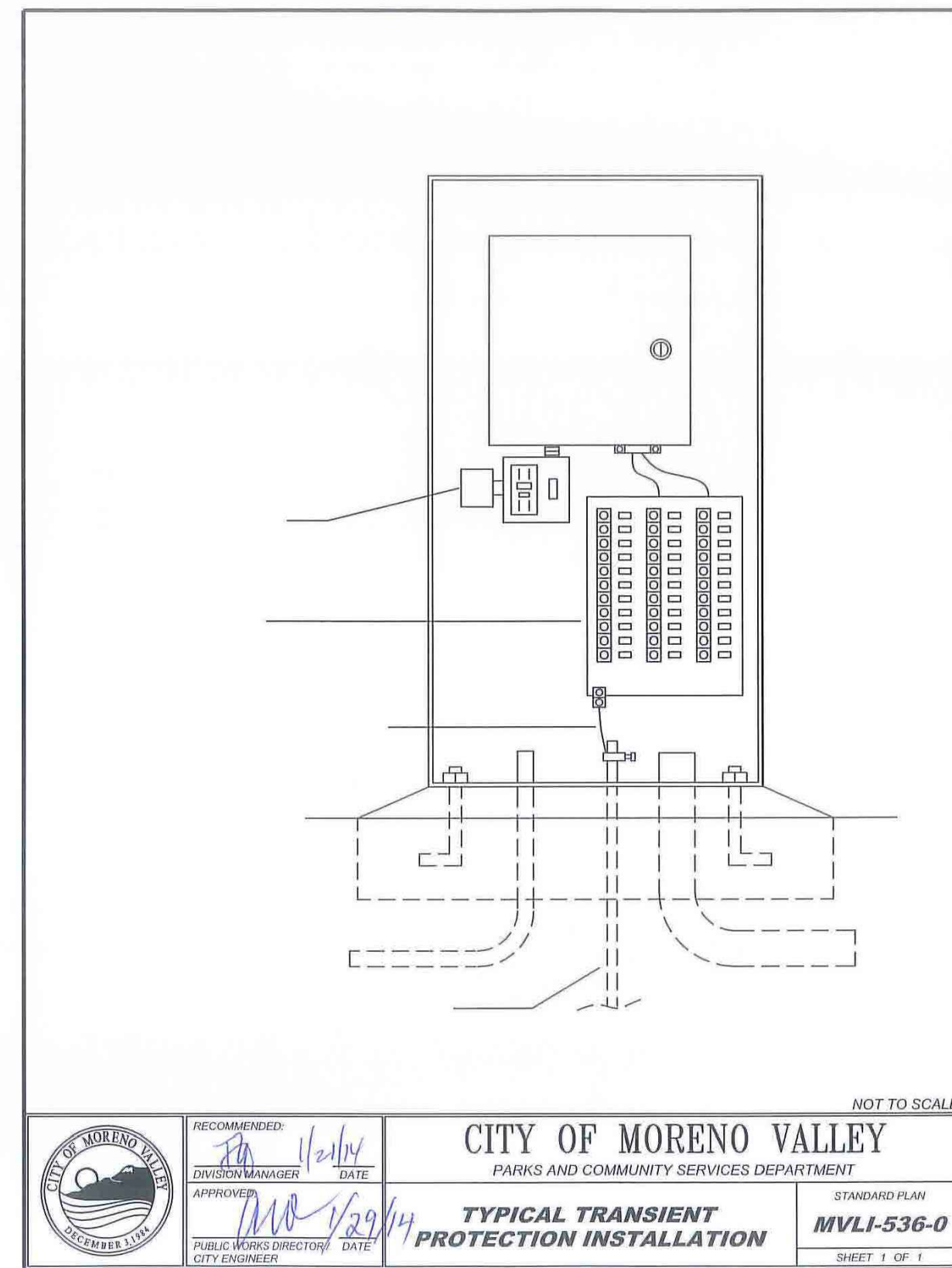

1
CITY OF MORENO VALLEY
PARKS AND COMMUNITY SERVICES DEPARTMENT
TYPICAL TRANSIENT PROTECTION INSTALLATION
MVLI-536-0
SHEET 1 OF 1

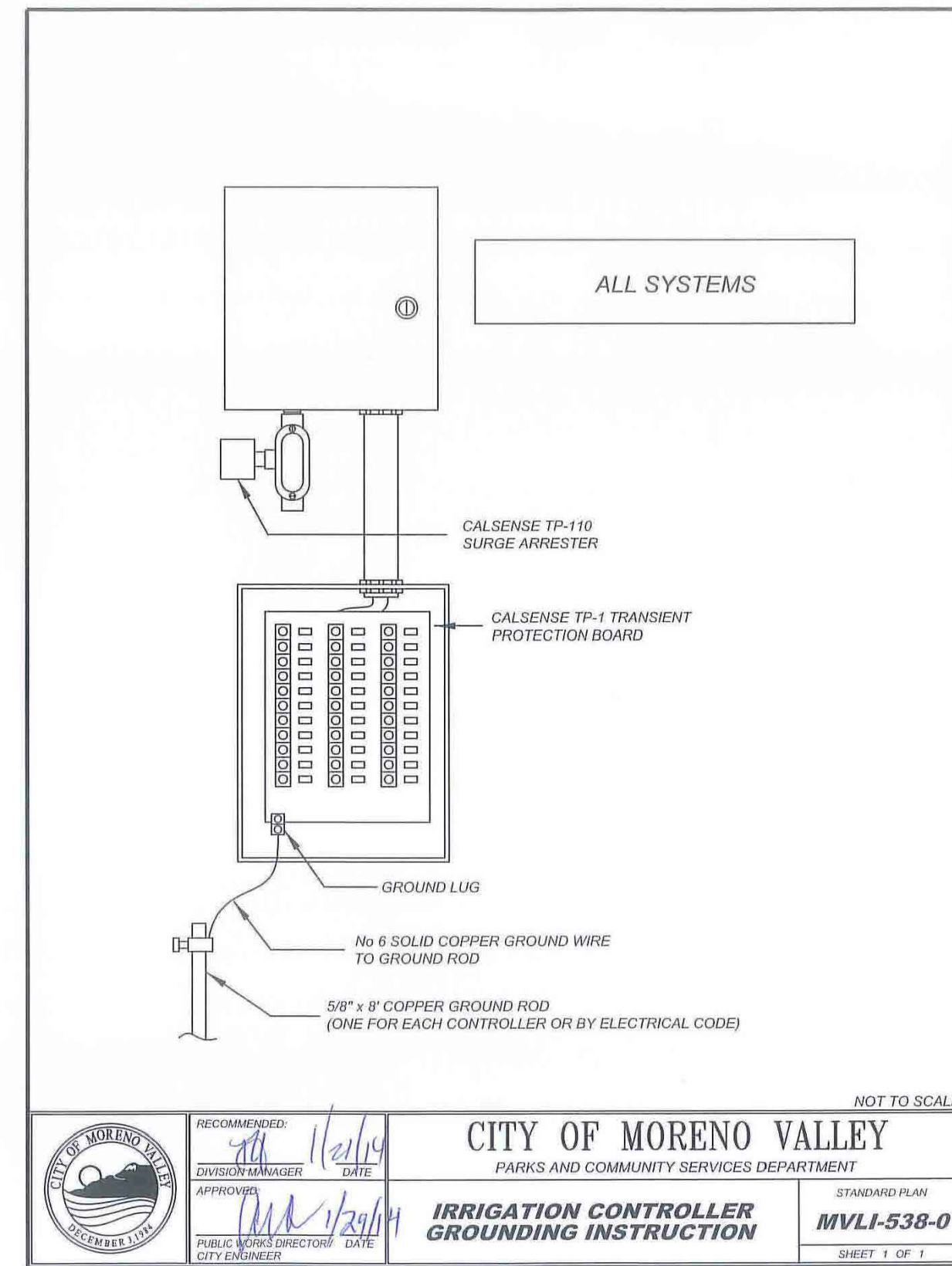

2
CITY OF MORENO VALLEY
PARKS AND COMMUNITY SERVICES DEPARTMENT
IRRIGATION CONTROLLER GROUNDING INSTRUCTION
MVLI-538-0
SHEET 1 OF 1

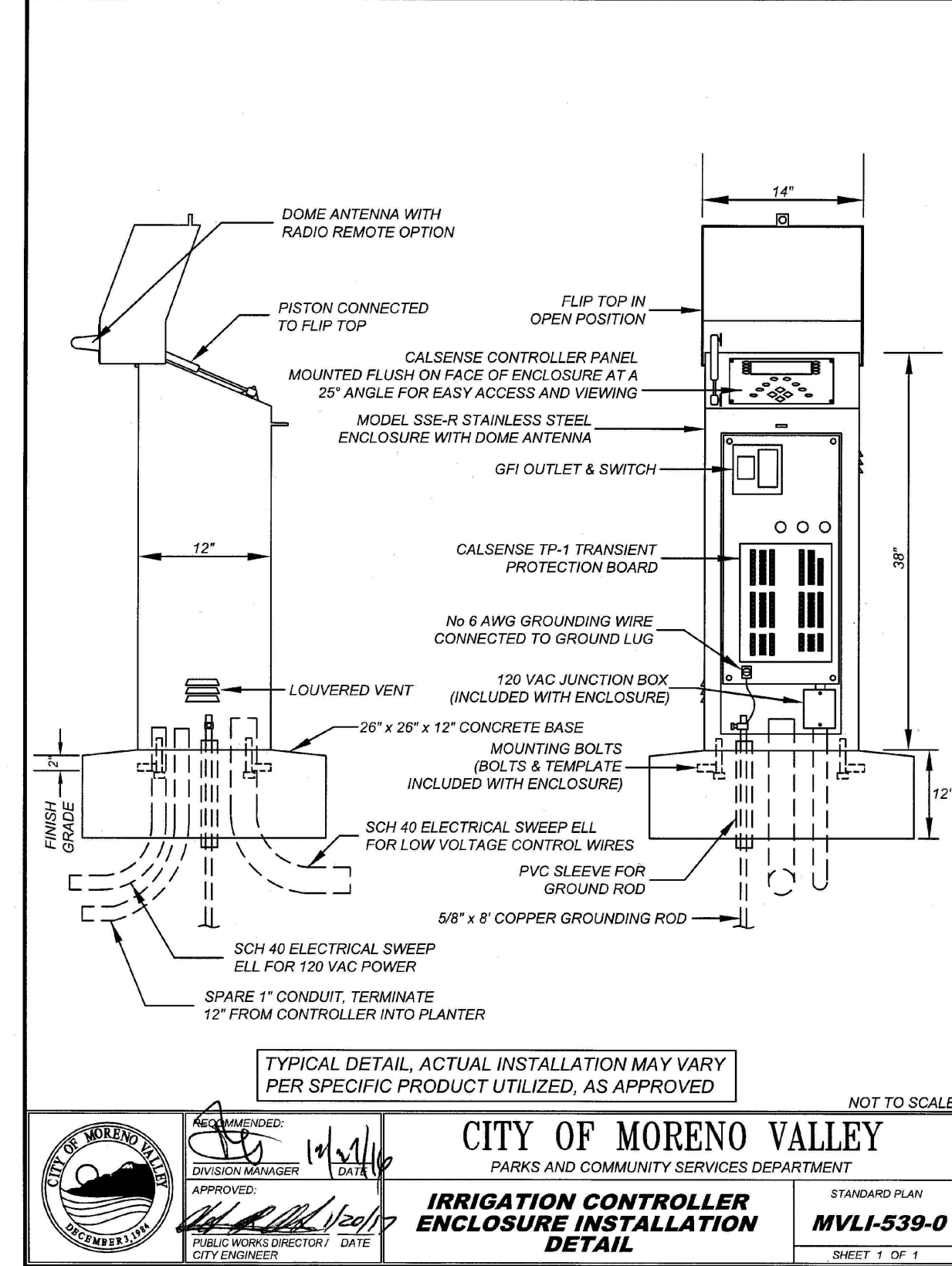

3
CITY OF MORENO VALLEY
PARKS AND COMMUNITY SERVICES DEPARTMENT
IRRIGATION CONTROLLER ENCLOSURE INSTALLATION DETAIL
MVLI-539-0
SHEET 1 OF 1

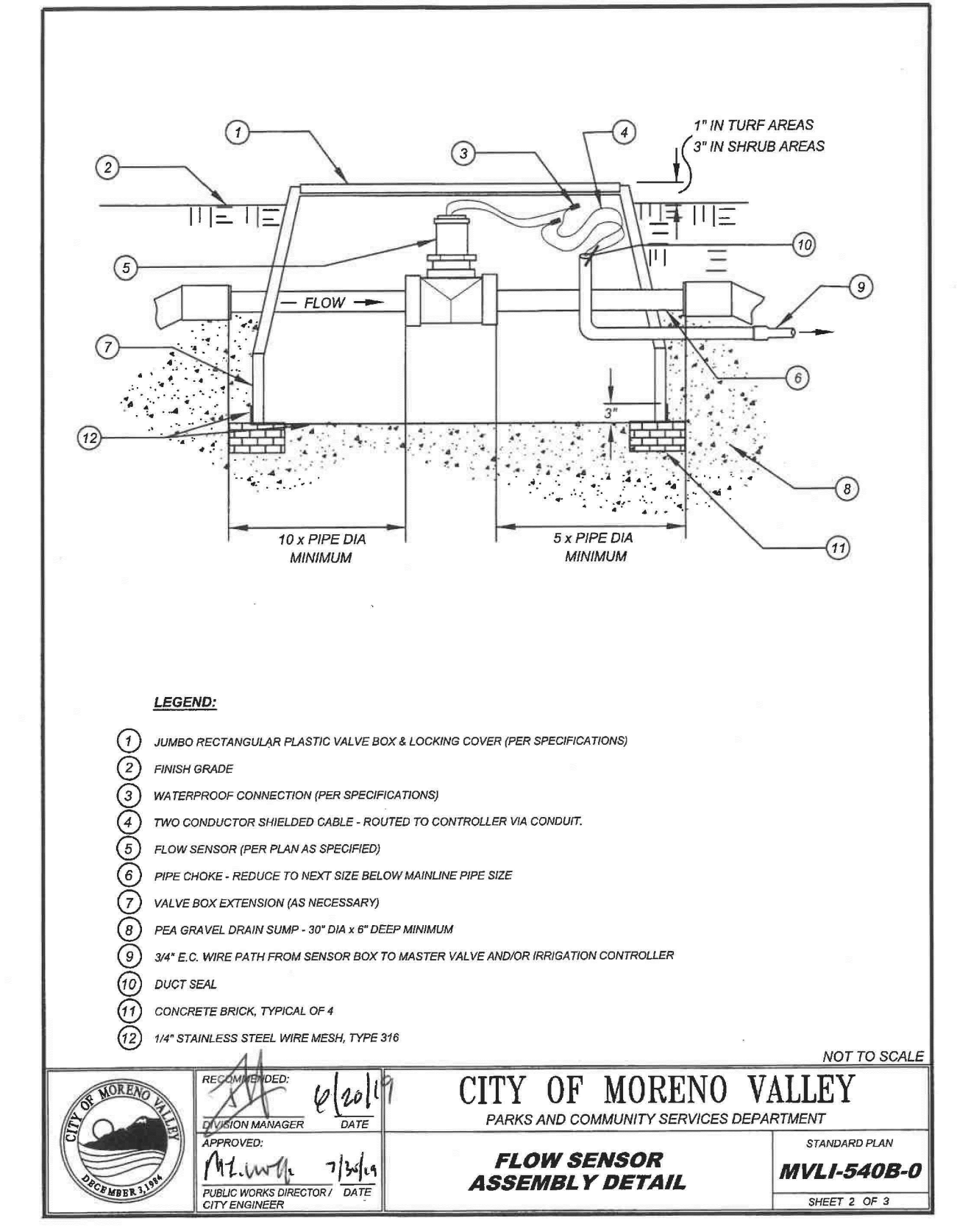

4
CITY OF MORENO VALLEY
PARKS AND COMMUNITY SERVICES DEPARTMENT
FLOW SENSOR ASSEMBLY DETAIL
MVLI-540-0
SHEET 2 OF 3

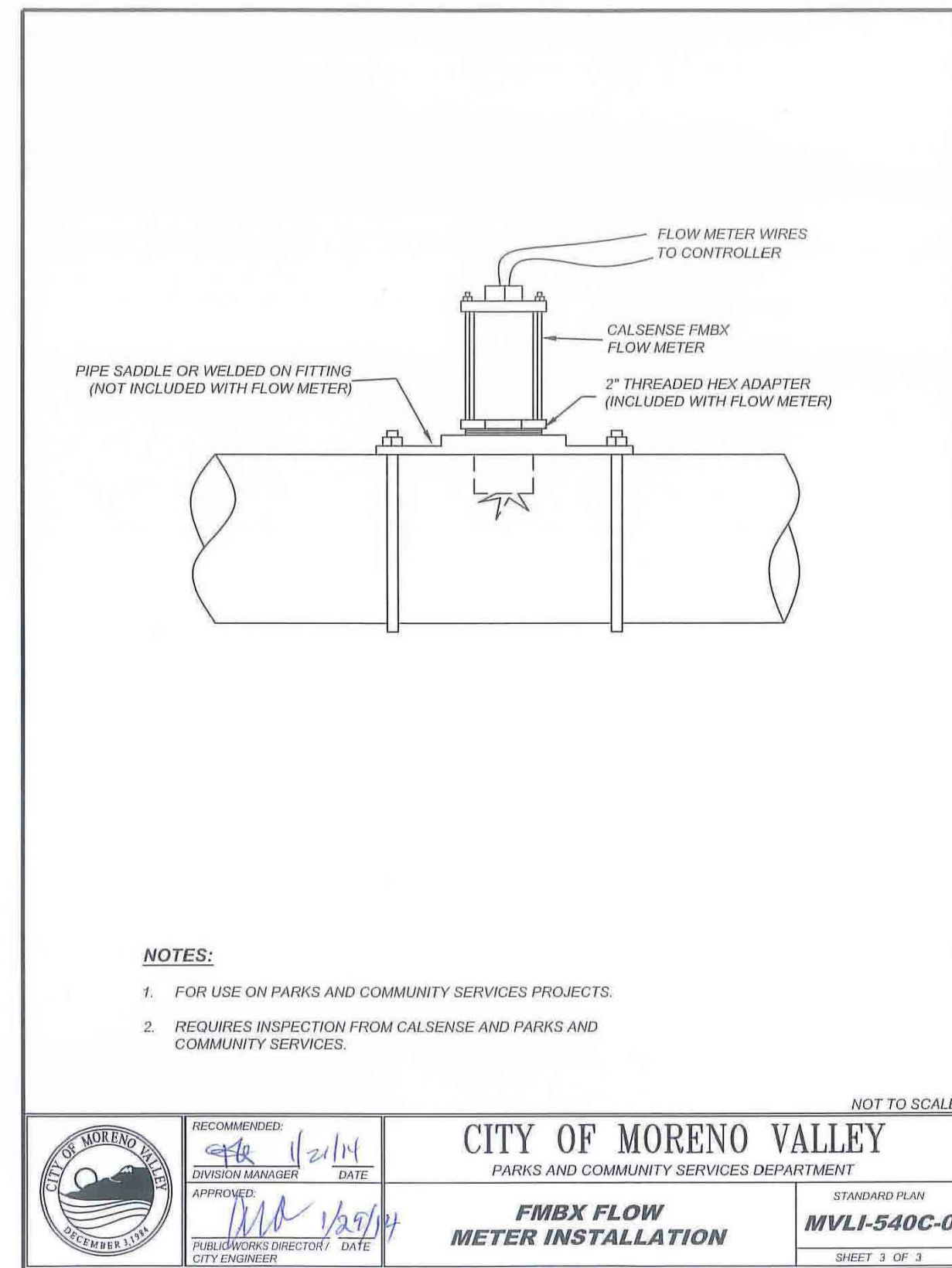

5
CITY OF MORENO VALLEY
PARKS AND COMMUNITY SERVICES DEPARTMENT
FBX FLOW METER INSTALLATION
MVLI-540C-0
SHEET 3 OF 3

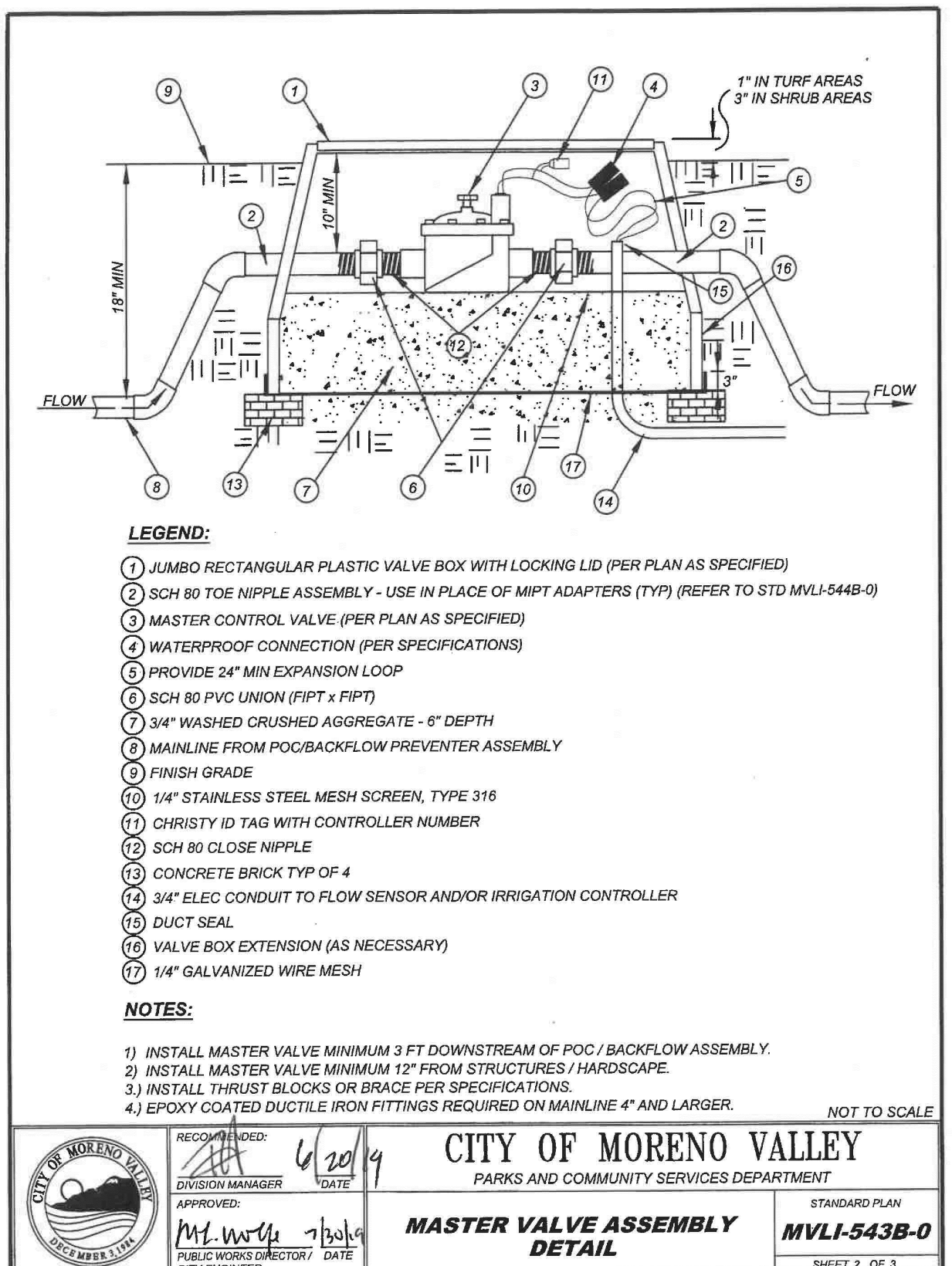

6
CITY OF MORENO VALLEY
PARKS AND COMMUNITY SERVICES DEPARTMENT
MASTER VALVE ASSEMBLY DETAIL
MVLI-543B-0
SHEET 2 OF 3

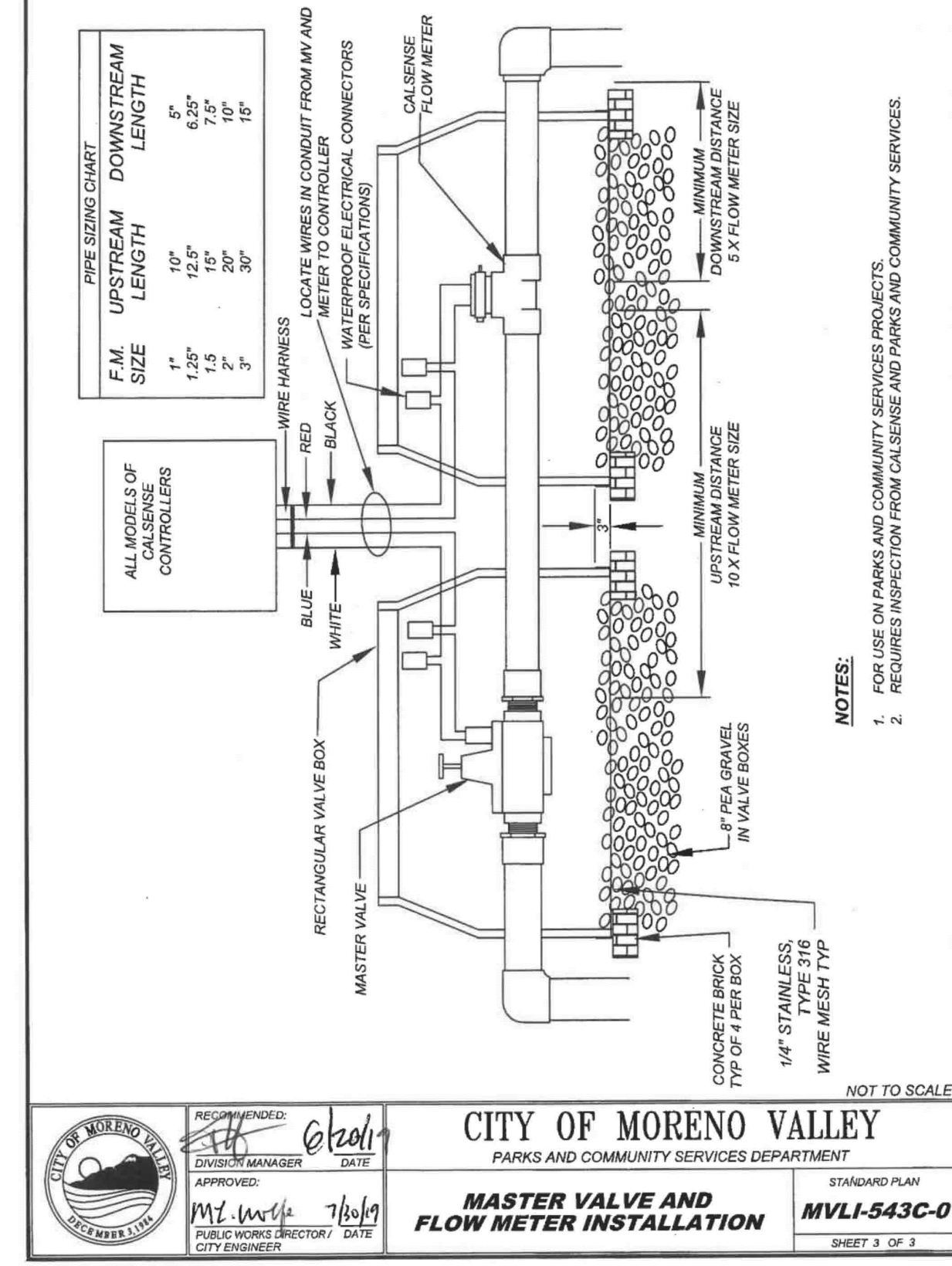

7
CITY OF MORENO VALLEY
PARKS AND COMMUNITY SERVICES DEPARTMENT
MASTER VALVE AND FLOW METER INSTALLATION
MVLI-543C-0
SHEET 3 OF 3

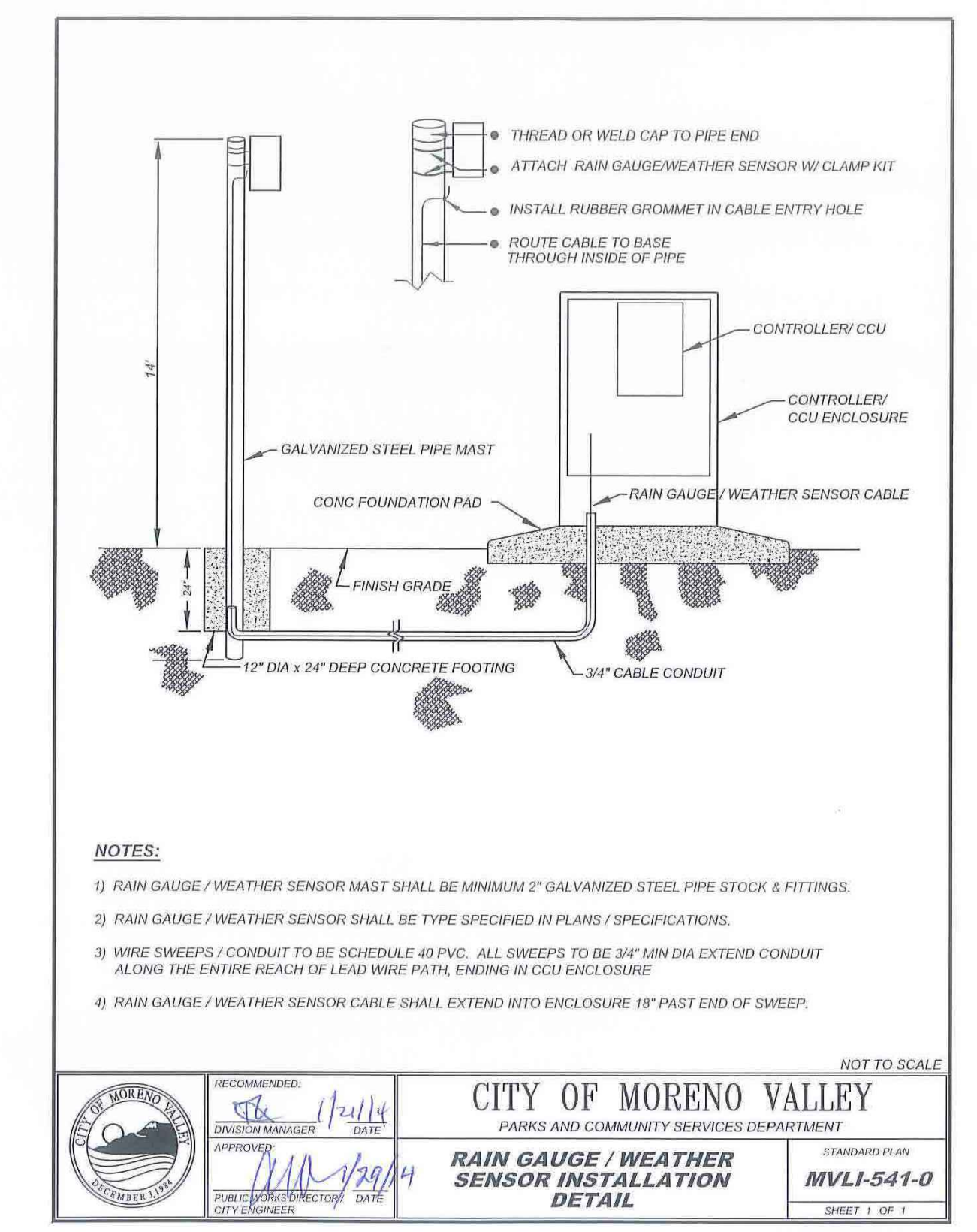

8
CITY OF MORENO VALLEY
PARKS AND COMMUNITY SERVICES DEPARTMENT
RAIN GAUGE / WEATHER SENSOR INSTALLATION DETAIL
MVLI-541-0
SHEET 1 OF 1

NO WORK SHALL BE DONE ON THIS SITE UNTIL BELOW AGENCY IS NOTIFIED OF INTENTION TO GRADE OR EXCAVATE.
Underground Service Alert
Call: TOLL FREE 811
WWW.CALL811.COM
TWO WORKING DAYS BEFORE YOU DIG

BASIS OF BEARING
THE BASIS OF BEARINGS FOR THIS SURVEY IS THE CALIFORNIA STATE PLANE COORDINATE SYSTEM CCS83, ZONE 6, BASED LOCALLY ON CONTROL STATIONS "R48", "R47", AND "R50C" NAD 83 (NRSR2011) EPOCH 2010.00 AS SHOWN HEREON. ALL BEARINGS SHOWN ON THIS MAP ARE GRID. QUOTED BEARINGS AND DISTANCES FROM REFERENCE MAPS OR DEEDS ARE, AS SHOWN PER THAT RECORD REFERENCE. ALL DISTANCES SHOWN ARE GROUND DISTANCES UNLESS SPECIFIED OTHERWISE. GRID DISTANCES MAY BE OBTAINED BY MULTIPLYING THE GROUND DISTANCE BY A COMBINATION FACTOR OF 0.99993579. CALCULATIONS ARE MADE AT TYP TAGGED "LS 5174", DOWN 0.2 IN WELL PER TRACT 36882, MB 454-07-39 WITH COORDINATES OF: N: 227736.255000000, E: 6286431.210000000 USING AN ELEVATION OF 1665.533

REVIEW BY CITY STAFF

OFFICE	INITIAL	DATE
ENGINEERING DIVISION MANAGER		
LAND DEVELOPMENT		
PLANNING		
TRANSPORTATION		
PARKS AND COMMUNITY SERVICES		
SPECIAL DISTRICTS		
STORM WATER MANAGEMENT PROGRAM		

NO.	DATE	INITIALS	E.O.R.	REVISION	DESCRIPTION	DATE	APPR

LANDSCAPE ARCHITECT OF RECORD'S SEAL
REGISTERED LANDSCAPE ARCHITECT
SHANNON P. KARLSON
R.L.A. #6070 (EXP. 10/31/23)

bmla
LANDSCAPE ARCHITECTURE
310 NORTH JOY STREET | CORONA, CA 92627
TEL: 951.261.1291 | FAX: 951.267.6691
PLANS PREPARED UNDER THE SUPERVISION OF:
SHANNON P. KARLSON
R.L.A. #6070 (EXP. 10/31/23)
8/21/23 DATE

CITY OF MORENO VALLEY
PARKS AND COMMUNITY SERVICES DEPARTMENT
PUBLIC PARK IMPROVEMENT PLANS
TRACT 38236
STELLA PONTE & BELLA SERA
IRRIGATION DETAILS

LID-1
SHEET 15 OF 23
CITY ID No: ---

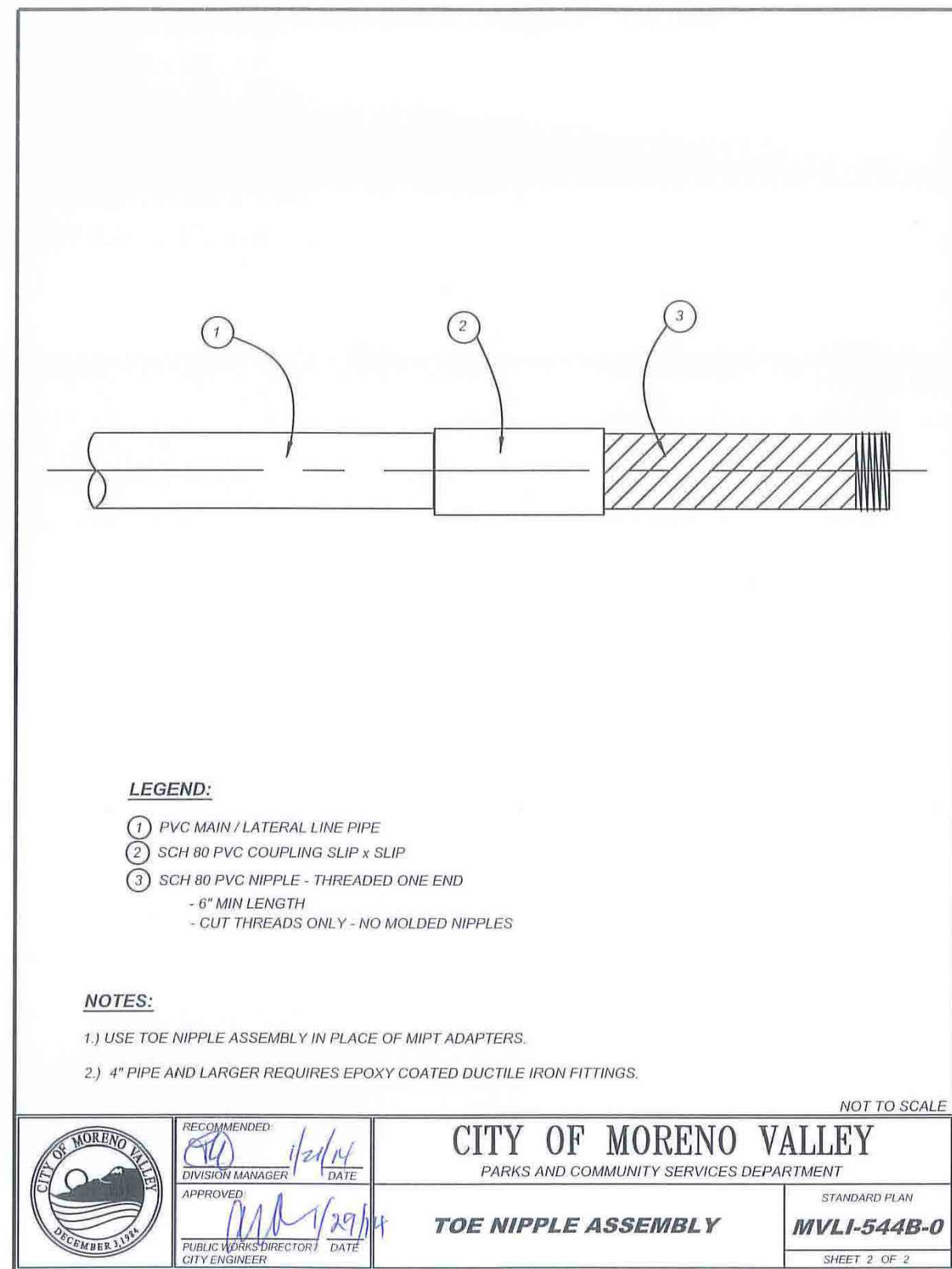

1

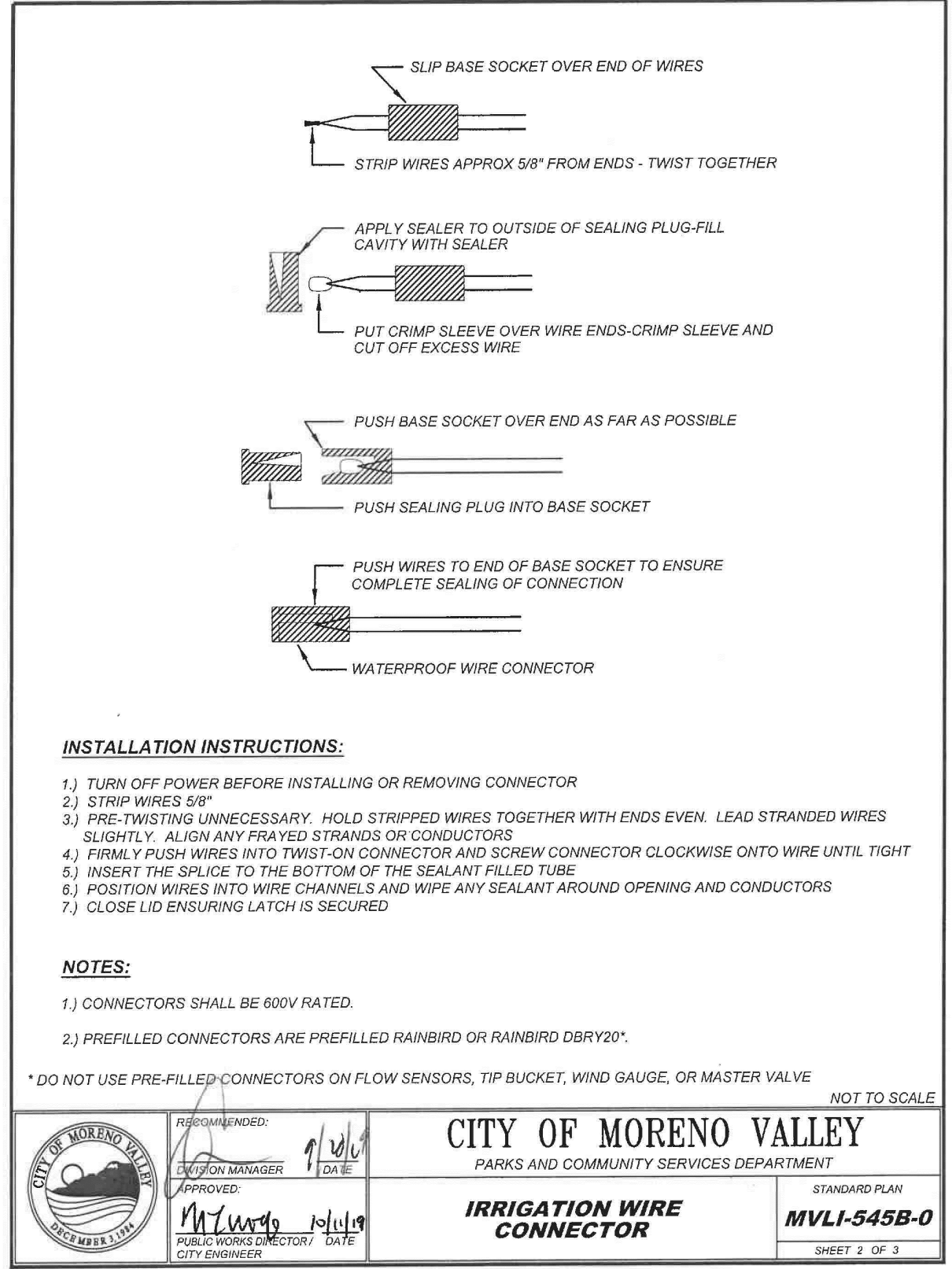

2

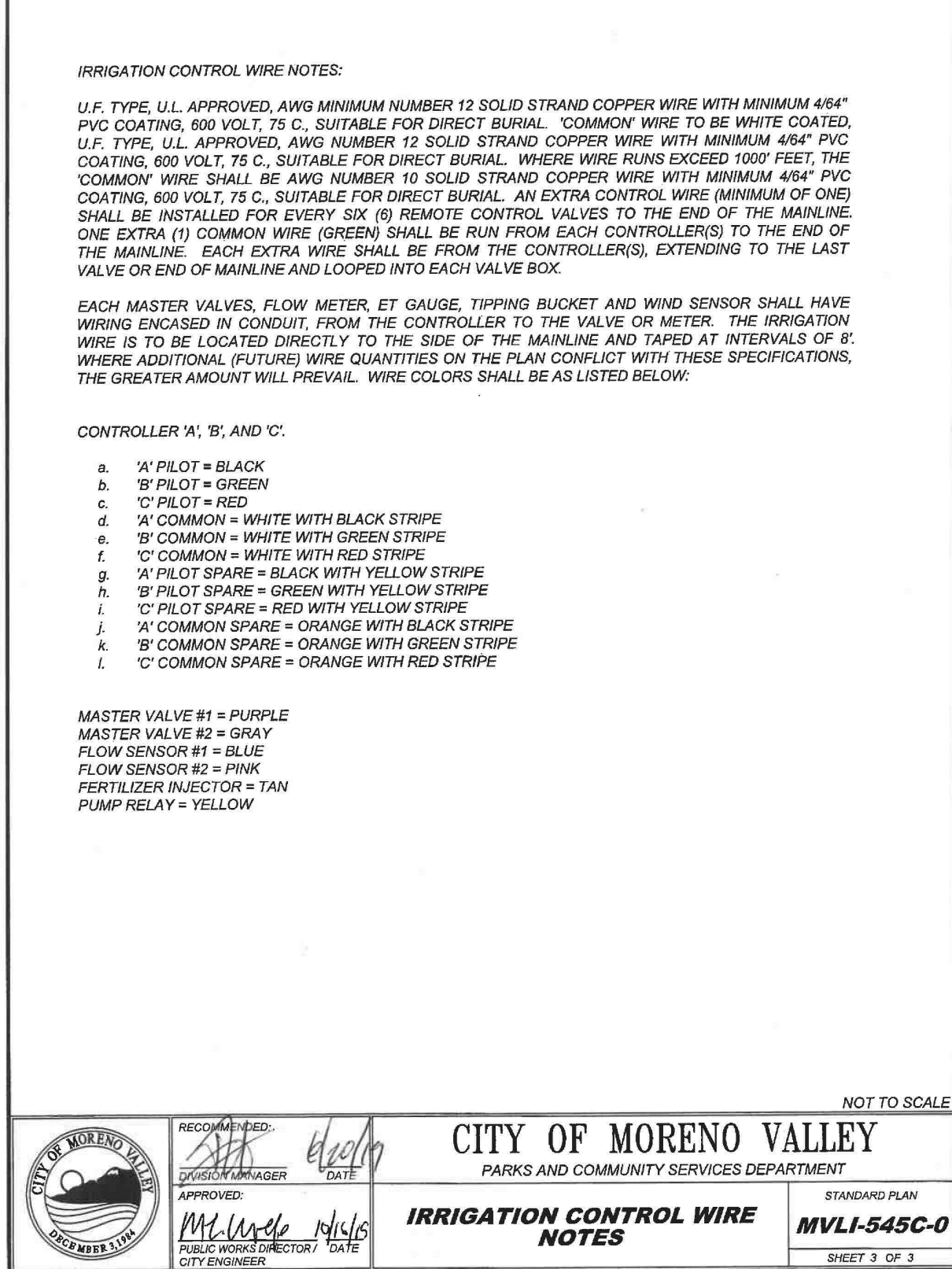

3

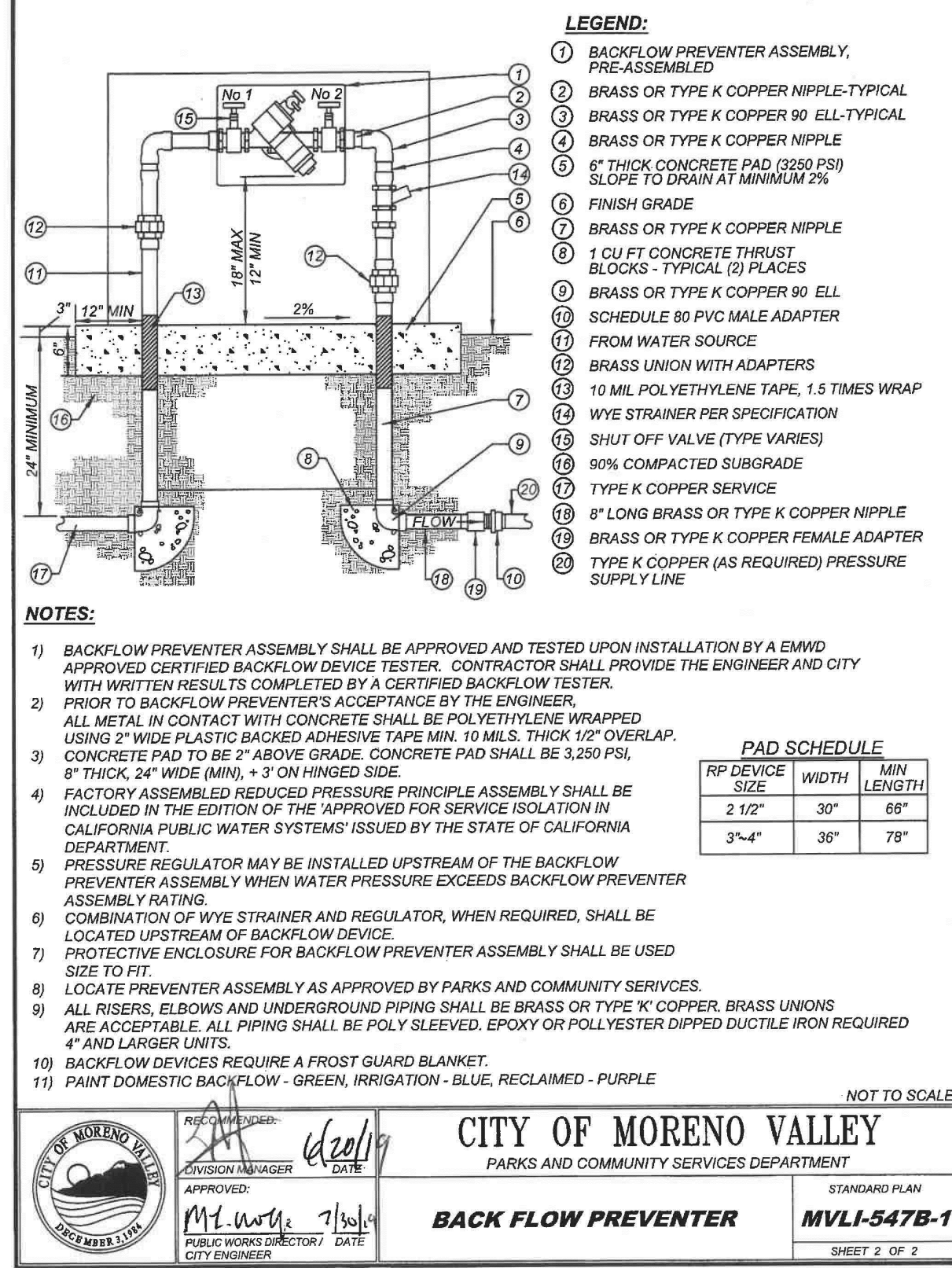

4

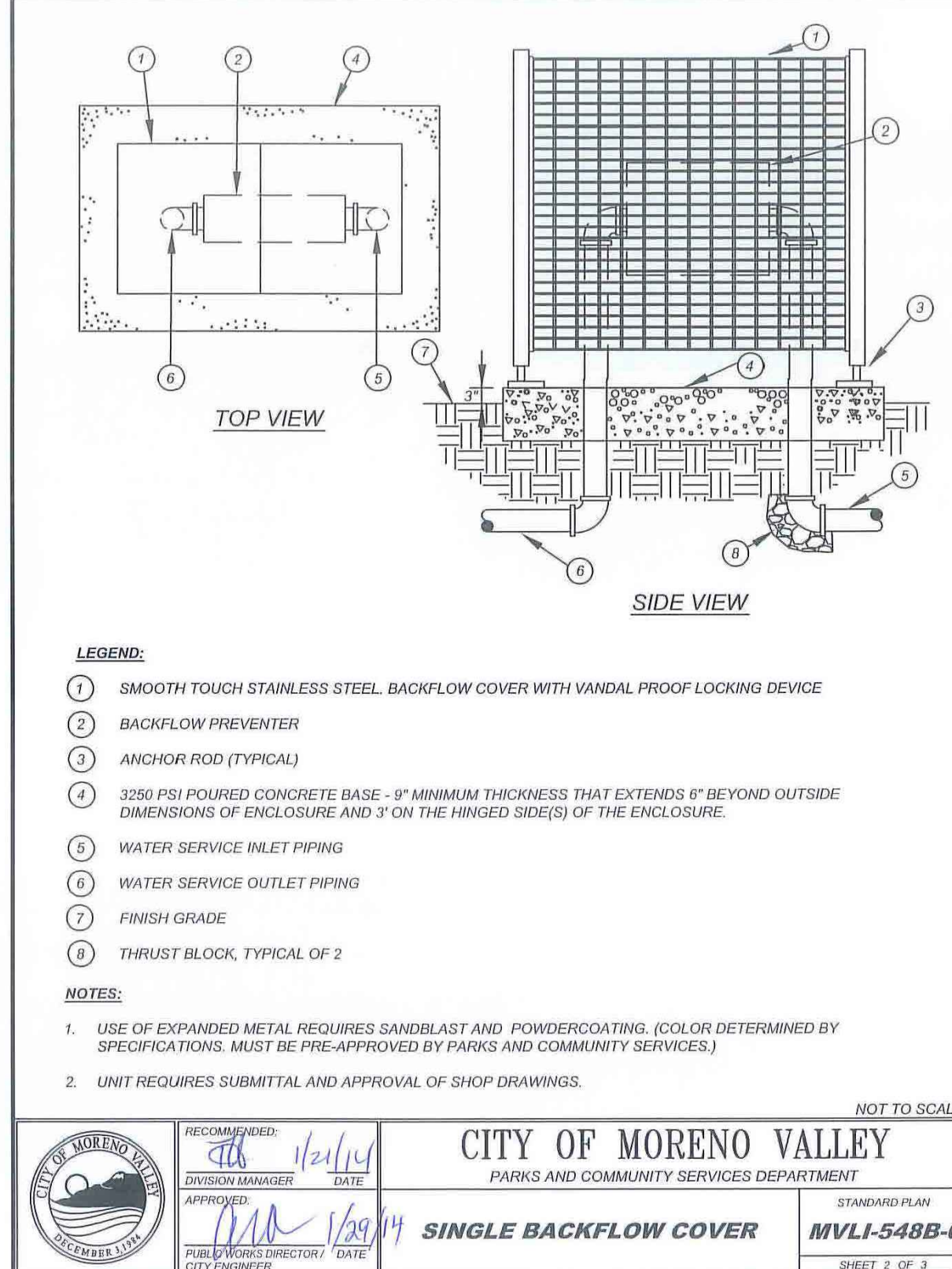

5

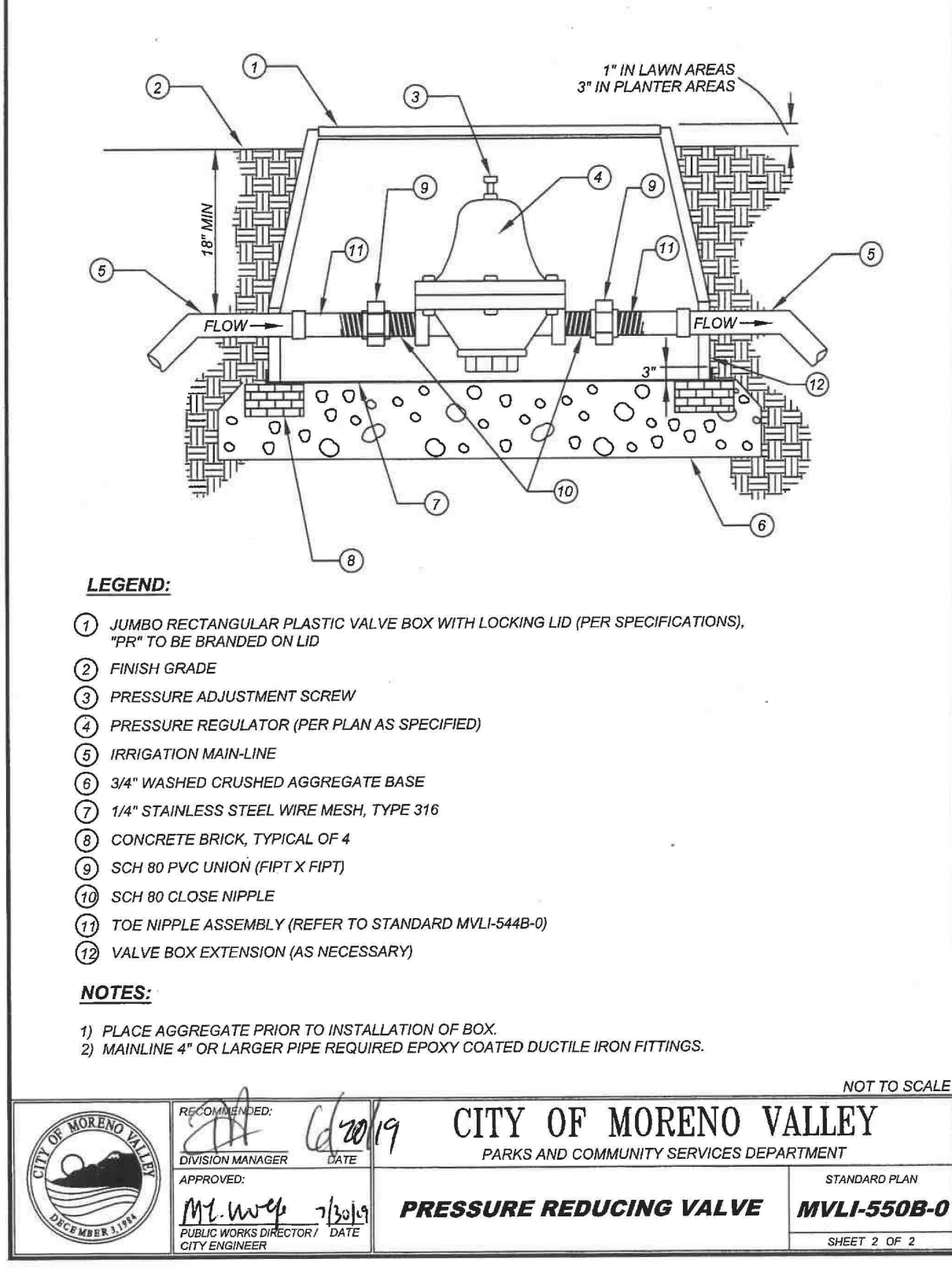

6

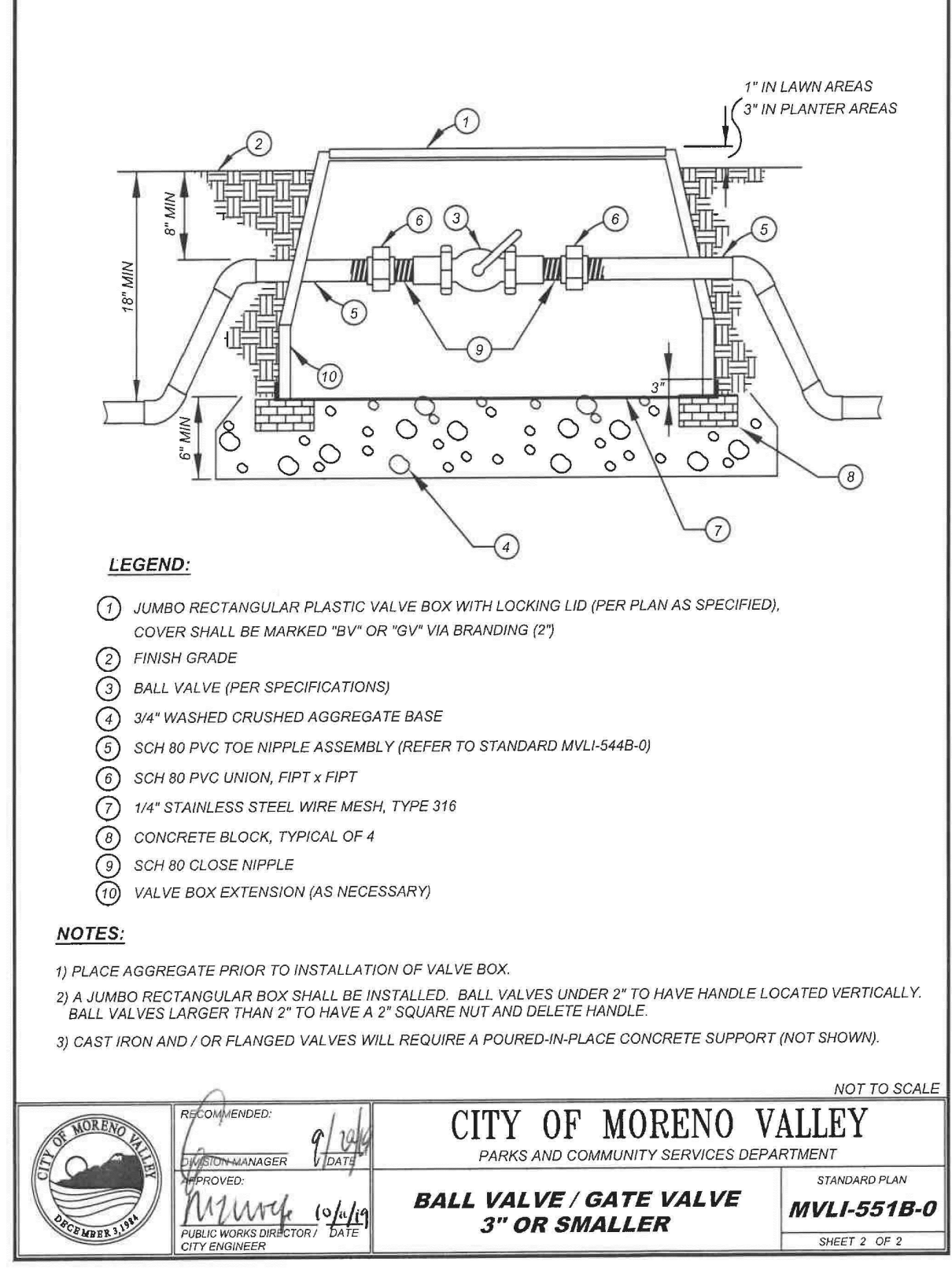

7

NO WORK SHALL BE DONE ON THIS SITE UNTIL BELOW AGENCY IS NOTIFIED OF INTENTION TO GRADE OR EXCAVATE. Underground Service Alert Call: TOLL FREE 811 WWW.CALL811.COM TWO WORKING DAYS BEFORE YOU DIG	BASIS OF BEARING THE BASIS OF BEARINGS FOR THIS SURVEY IS THE CALIFORNIA STATE PLANE COORDINATE SYSTEM CCS83, ZONE 6, BASED LOCALLY ON CONTROL STATIONS "R48", "R47", AND "R80" NAD 83 (NRSR2011) EPOCH 2010.00 AS SHOWN HEREON. ALL BEARINGS SHOWN ON THIS MAP ARE GRID. QUOTED BEARINGS AND DISTANCES FROM REFERENCE MAPS OR DEEDS ARE AS SHOWN PER THAT RECORD REFERENCE. ALL DISTANCES SHOWN ARE GROUND DISTANCES UNLESS SPECIFIED OTHERWISE. GRID DISTANCES MAY BE OBTAINED BY MULTIPLYING THE GROUND DISTANCE BY A CONVERSION FACTOR OF 0.99999579. CALCULATIONS ARE MADE AT TYP. TAGGED "LS 5174", DOWN 0.2 IN WELL PER TRACT 36882, MB 454-07-29 WITH COORDINATES OF N: 227736.255000000, E: 6280431.21000000 USING AN ELEVATION OF 1665.533	REVIEW BY CITY STAFF <table border="1"> <tr> <th>OFFICE</th> <th>INITIAL</th> <th>DATE</th> <th>NO.</th> <th>DATE</th> <th>INITIALS</th> <th>E.O.R.</th> <th>REVISION</th> <th>DESCRIPTION</th> <th>DATE</th> <th>APPR</th> </tr> <tr> <td>ENGINEERING DIVISION MANAGER</td> <td></td> <td></td> <td></td> <td></td> <td></td> <td></td> <td></td> <td></td> <td></td> <td></td> </tr> <tr> <td>LAND DEVELOPMENT</td> <td></td> <td></td> <td></td> <td></td> <td></td> <td></td> <td></td> <td></td> <td></td> <td></td> </tr> <tr> <td>PLANNING</td> <td></td> <td></td> <td></td> <td></td> <td></td> <td></td> <td></td> <td></td> <td></td> <td></td> </tr> <tr> <td>TRANSPORTATION</td> <td></td> <td></td> <td></td> <td></td> <td></td> <td></td> <td></td> <td></td> <td></td> <td></td> </tr> <tr> <td>PARKS AND COMMUNITY SERVICES</td> <td></td> <td></td> <td></td> <td></td> <td></td> <td></td> <td></td> <td></td> <td></td> <td></td> </tr> <tr> <td>SPECIAL DISTRICTS</td> <td></td> <td></td> <td></td> <td></td> <td></td> <td></td> <td></td> <td></td> <td></td> <td></td> </tr> <tr> <td>STORM WATER MANAGEMENT PROGRAM</td> <td></td> <td></td> <td></td> <td></td> <td></td> <td></td> <td></td> <td></td> <td></td> <td></td> </tr> </table>	OFFICE	INITIAL	DATE	NO.	DATE	INITIALS	E.O.R.	REVISION	DESCRIPTION	DATE	APPR	ENGINEERING DIVISION MANAGER											LAND DEVELOPMENT											PLANNING											TRANSPORTATION											PARKS AND COMMUNITY SERVICES											SPECIAL DISTRICTS											STORM WATER MANAGEMENT PROGRAM											LANDSCAPE ARCHITECT OF RECORD'S SEAL 	CITY OF MORENO VALLEY PUBLIC PARK IMPROVEMENT PLANS TRACT 38236 STELLA PONTE & BELLA SERA IRRIGATION DETAILS LID-2 SHEET 16 OF 23 CITY ID No. ---	PLANS PREPARED UNDER THE SUPERVISION OF: SHANNON P. KARLSON R.L.A. #6070 (EXP. 10/31/23) DATE: 8/21/23
	OFFICE	INITIAL	DATE	NO.	DATE	INITIALS	E.O.R.	REVISION	DESCRIPTION	DATE	APPR																																																																																		
ENGINEERING DIVISION MANAGER																																																																																													
LAND DEVELOPMENT																																																																																													
PLANNING																																																																																													
TRANSPORTATION																																																																																													
PARKS AND COMMUNITY SERVICES																																																																																													
SPECIAL DISTRICTS																																																																																													
STORM WATER MANAGEMENT PROGRAM																																																																																													

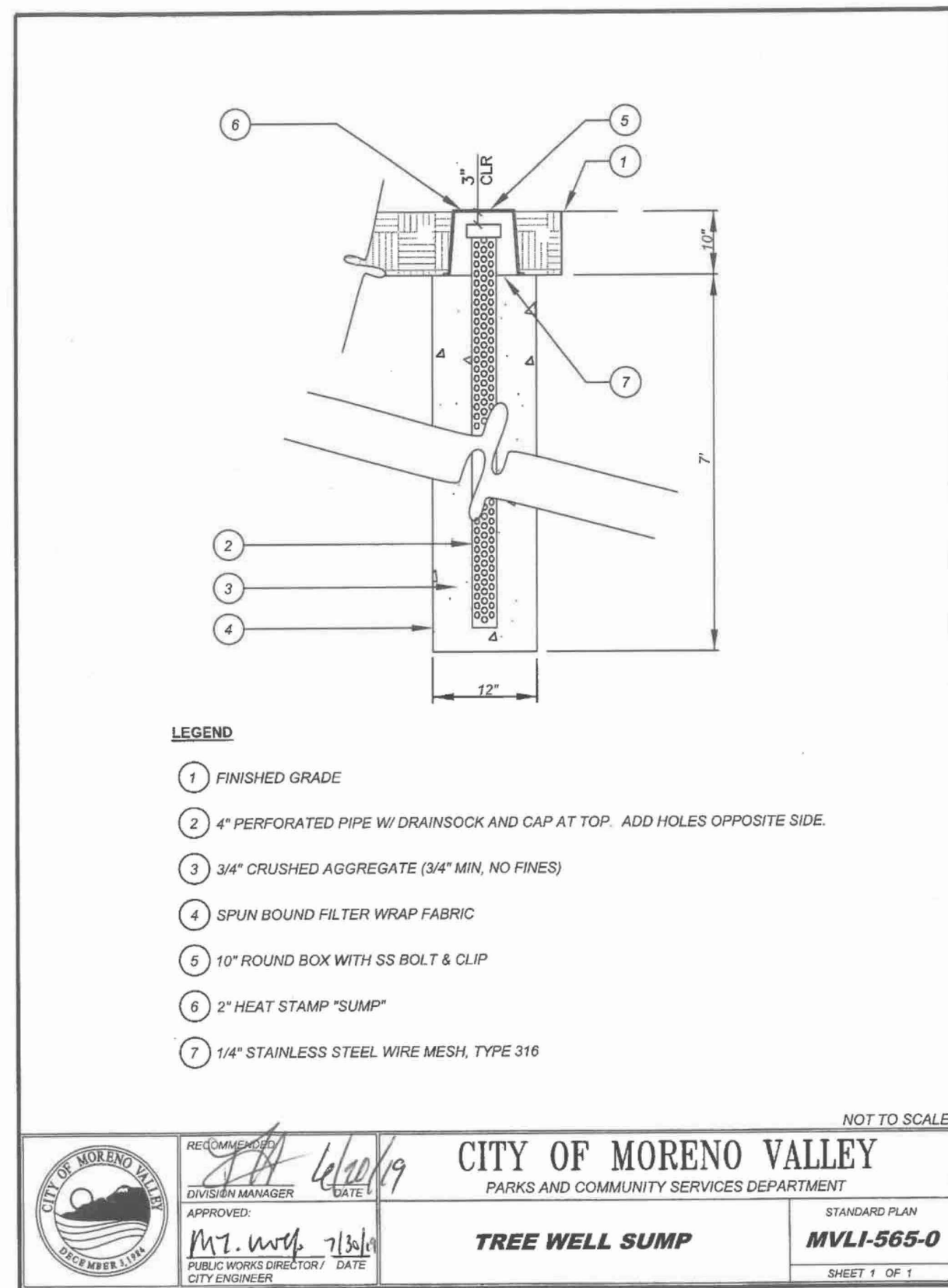

1

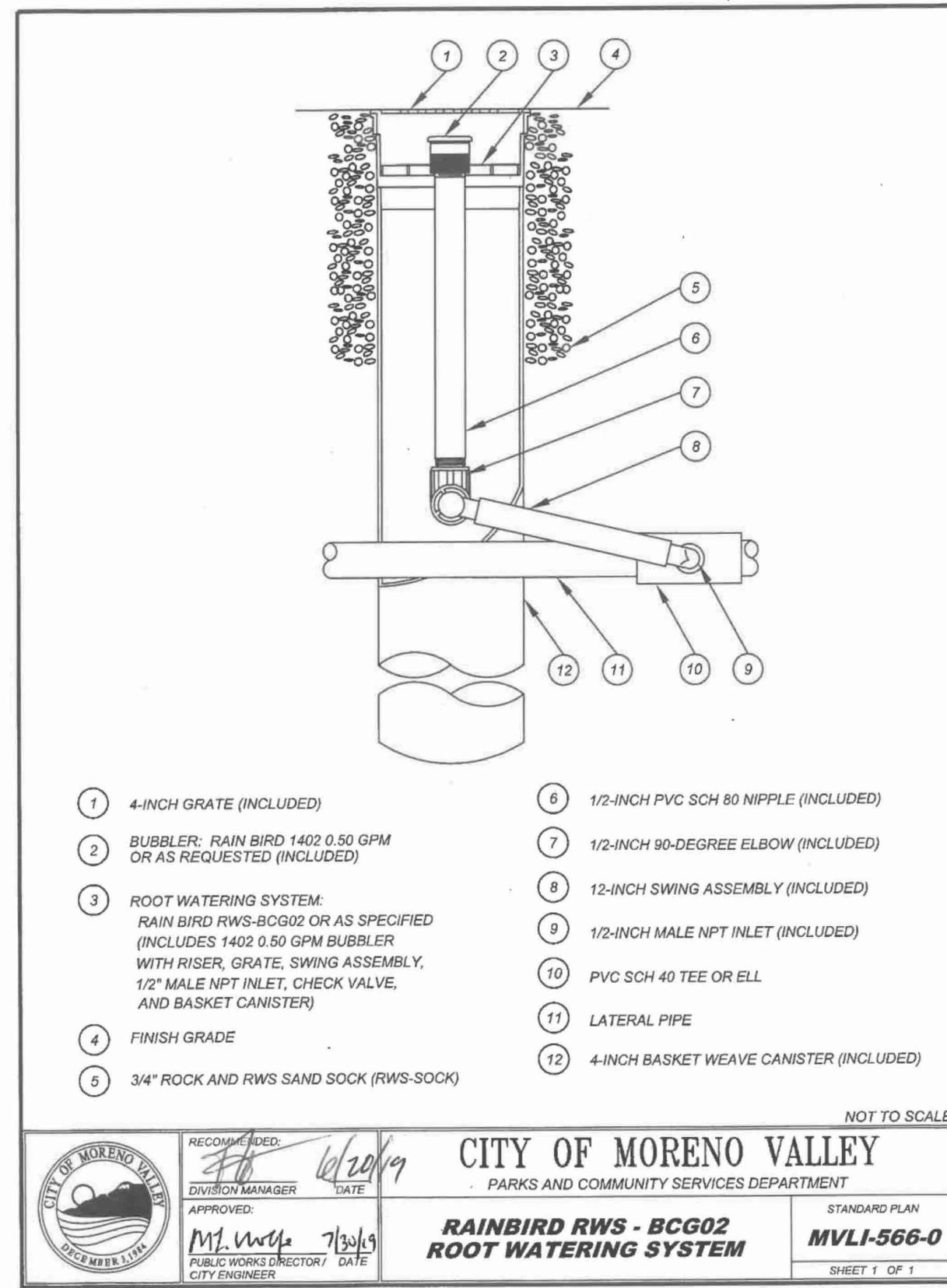

2

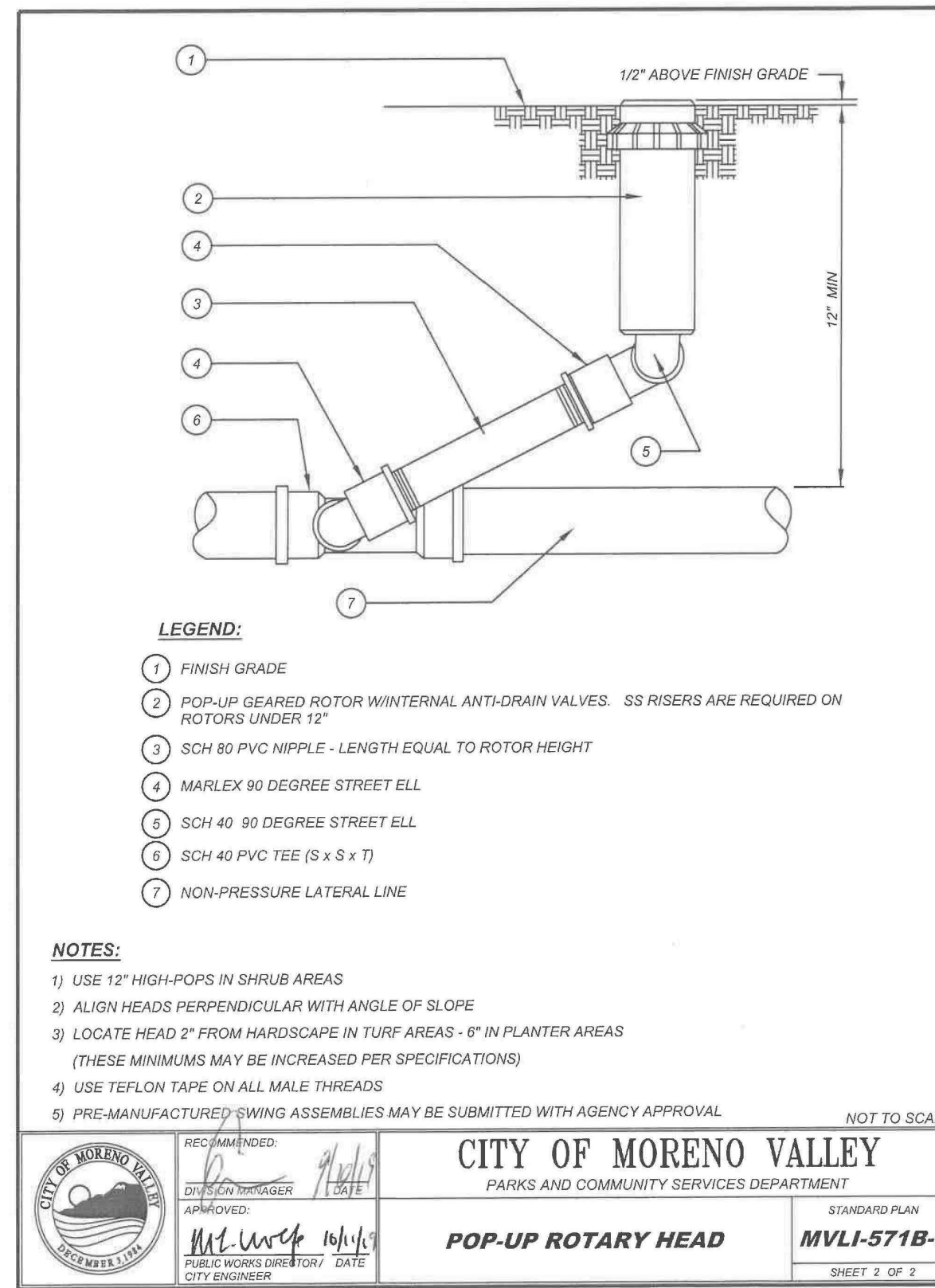

3

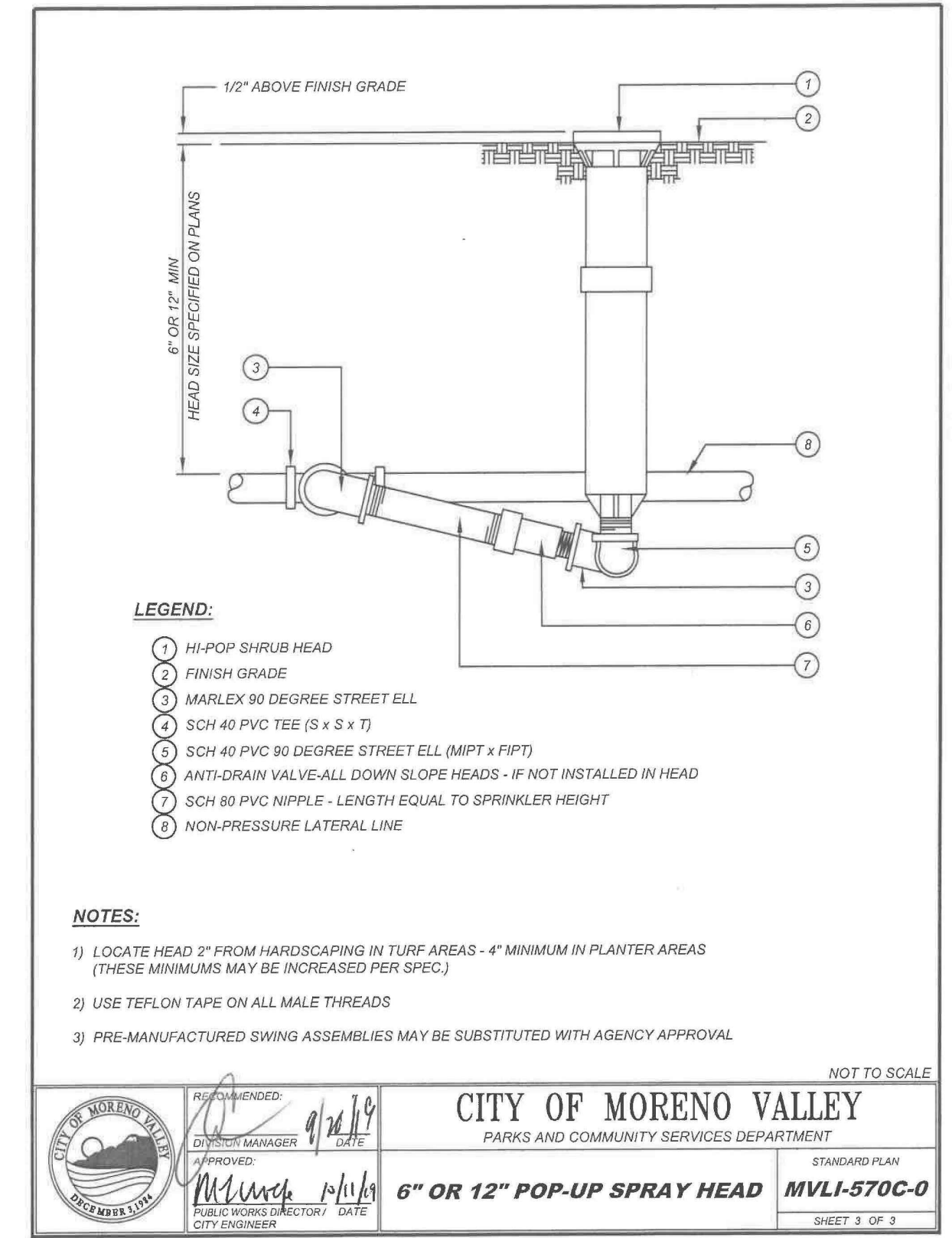

4

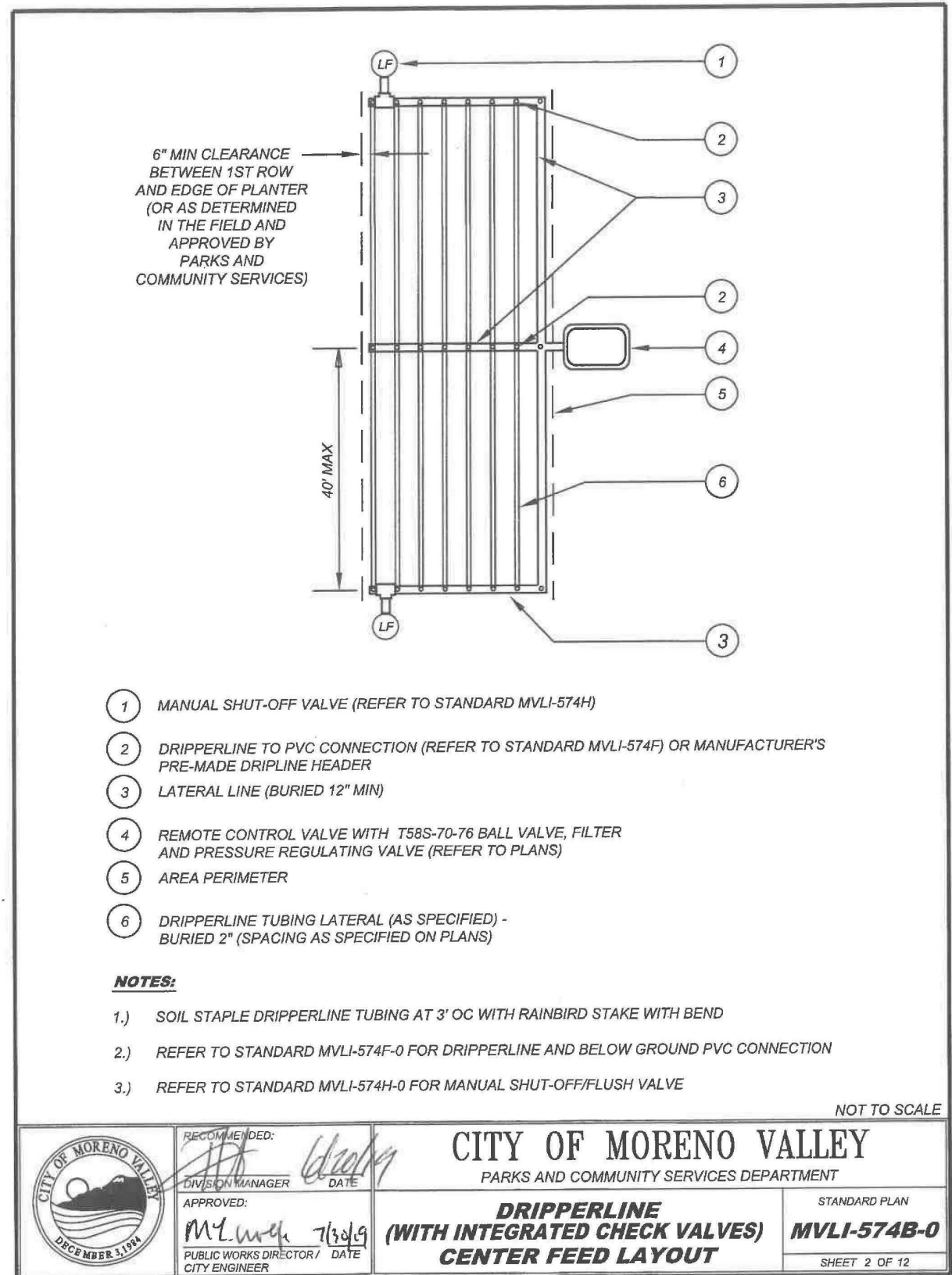

5

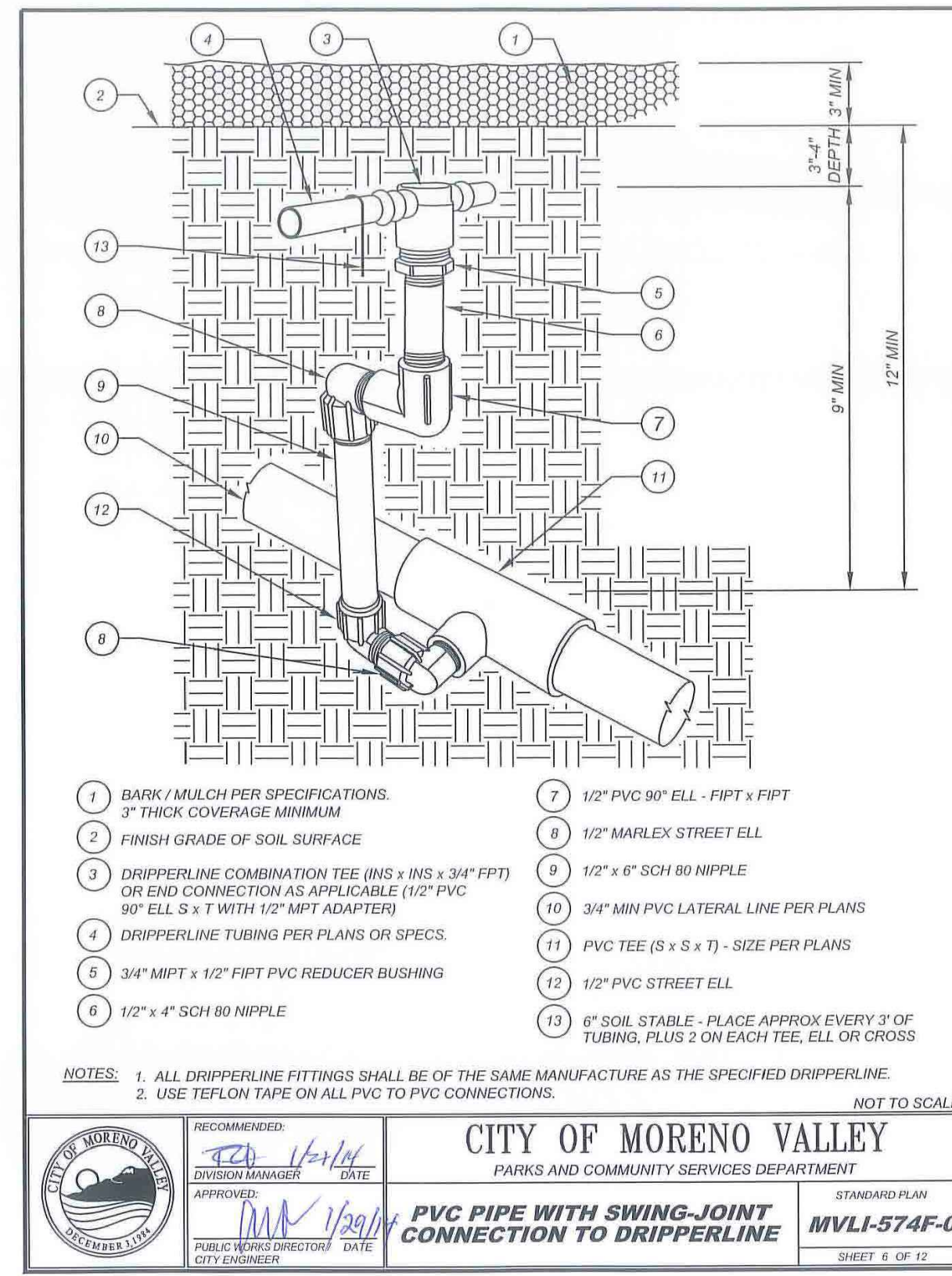

6

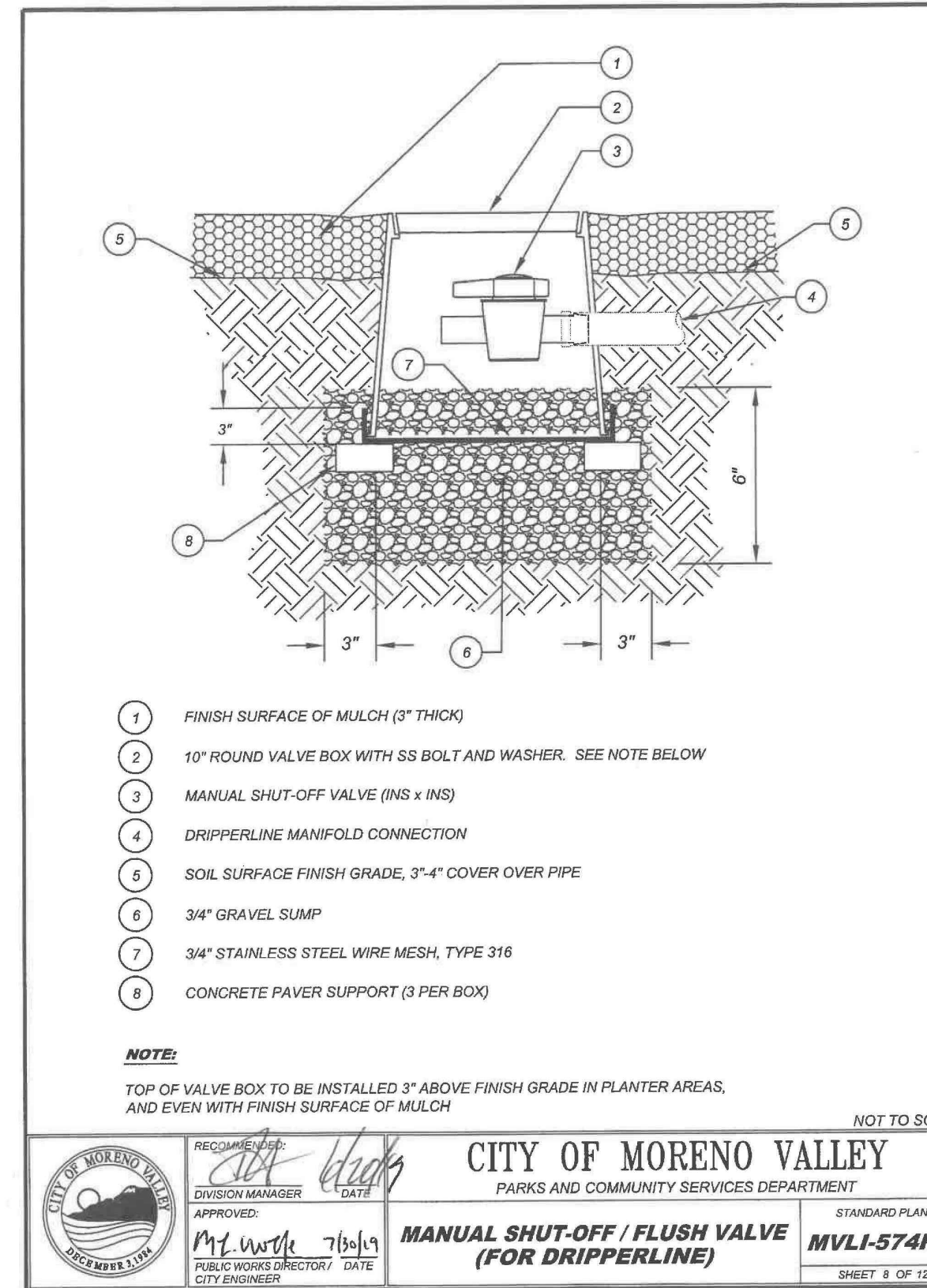

7

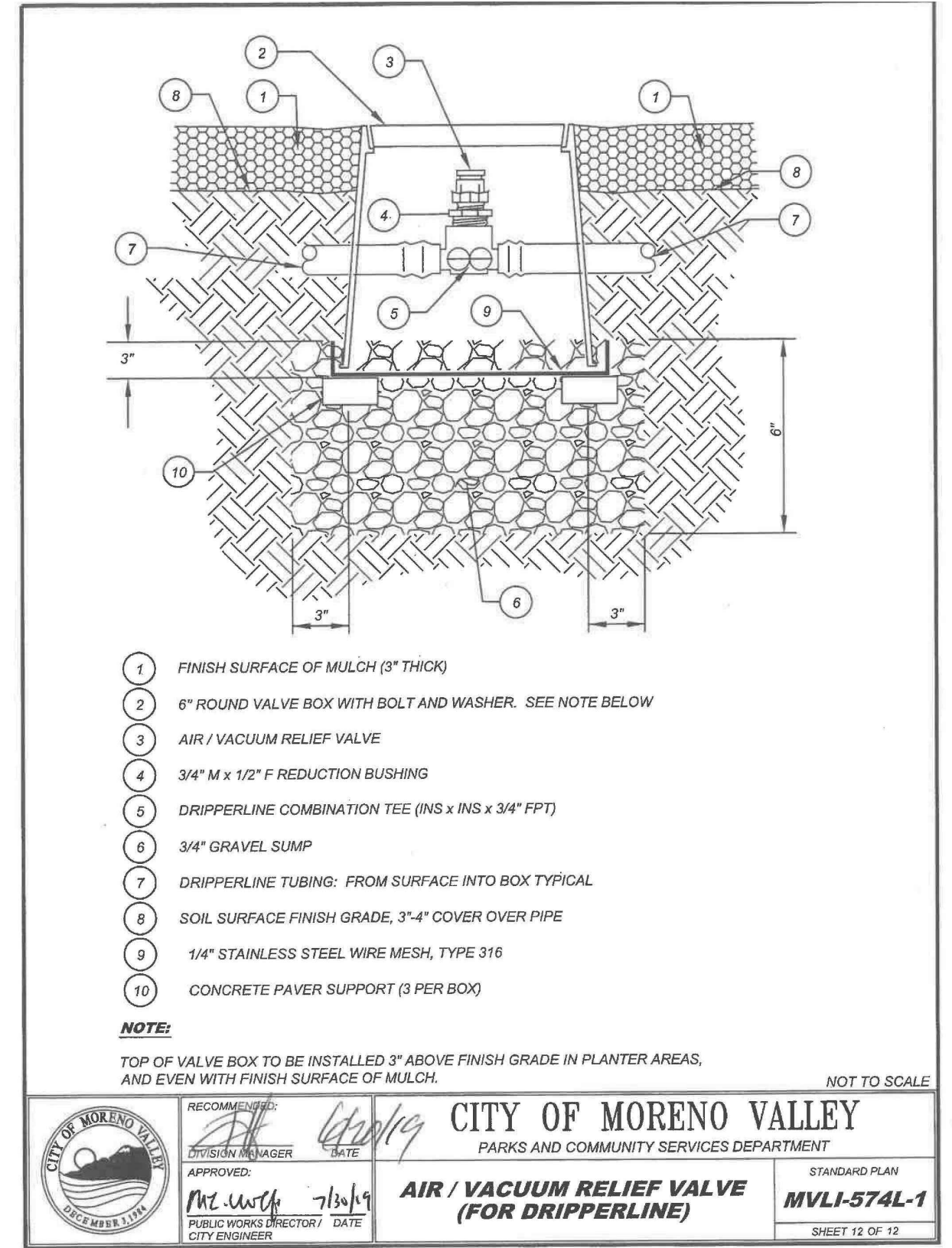

8

NO WORK SHALL BE DONE ON THIS SITE UNTIL BELOW AGENCY IS NOTIFIED OF INTENTION TO GRADE OR EXCAVATE.
Underground Service Alert
Call: TOLL FREE 811
WWW.CALL811.COM
TWO WORKING DAYS BEFORE YOU DIG

BASIS OF BEARING
THE BASIS OF BEARINGS FOR THIS SURVEY IS THE CALIFORNIA STATE PLANE COORDINATE SYSTEM CCS83, ZONE 6, BASED LOCALLY ON CONTROL STATIONS "TR45", "TR47", AND "SR80" NAD 83 (NRSR2011) EPOCH 2010.00 AS SHOWN HEREON. ALL BEARINGS SHOWN ON THIS MAP ARE GRID. QUOTED BEARINGS AND DISTANCES FROM REFERENCE MAPS OR DEEDS ARE, AS SHOWN PER THAT RECORD. REFERENCE ALL DISTANCES SHOWN ARE GROUND DISTANCES UNLESS SPECIFIED OTHERWISE. GRID DISTANCES MAY BE OBTAINED BY MULTIPLYING THE GROUND DISTANCE BY A COMBINATION FACTOR OF 0.99993579. CALCULATIONS ARE MADE AT TYP TAGGED "LS 5174", DOWN 0.2' IN WELL PER TRACT 36882, MB 454-07-39 WITH COORDINATES OF: N: 22736.255000000, E: 6280431.21000000 USING AN ELEVATION OF 1665.533

REVIEW BY CITY STAFF

OFFICE	INITIAL	DATE
ENGINEERING DIVISION MANAGER		
LAND DEVELOPMENT		
PLANNING		
TRANSPORTATION		
PARKS AND COMMUNITY SERVICES		
SPECIAL DISTRICTS		
STORM WATER MANAGEMENT PROGRAM		

REVISION

NO.	DATE	INITIALS	DESCRIPTION	DATE	APPR

LANDSCAPE ARCHITECT OF RECORD'S SEAL

REGISTERED LANDSCAPE ARCHITECT
SHANNON P. KARLSON
R.L.A. #6070 (EXP. 10/31/23)

bmla
LANDSCAPE ARCHITECTURE
310 NORTH JOY STREET | CORONA, CA 92627
TEL: 951.267.1124 | FAX: 951.267.6697

PLANS PREPARED UNDER THE SUPERVISION OF:
SHANNON P. KARLSON
R.L.A. #6070 (EXP. 10/31/23)
DATE: 8/21/23

CITY OF MORENO VALLEY
PUBLIC PARK IMPROVEMENT PLANS
TRACT 38236
STELLA PONTE & BELLA SERA
IRRIGATION DETAILS

LID-4
SHEET 18 OF 23
CITY ID No: ---

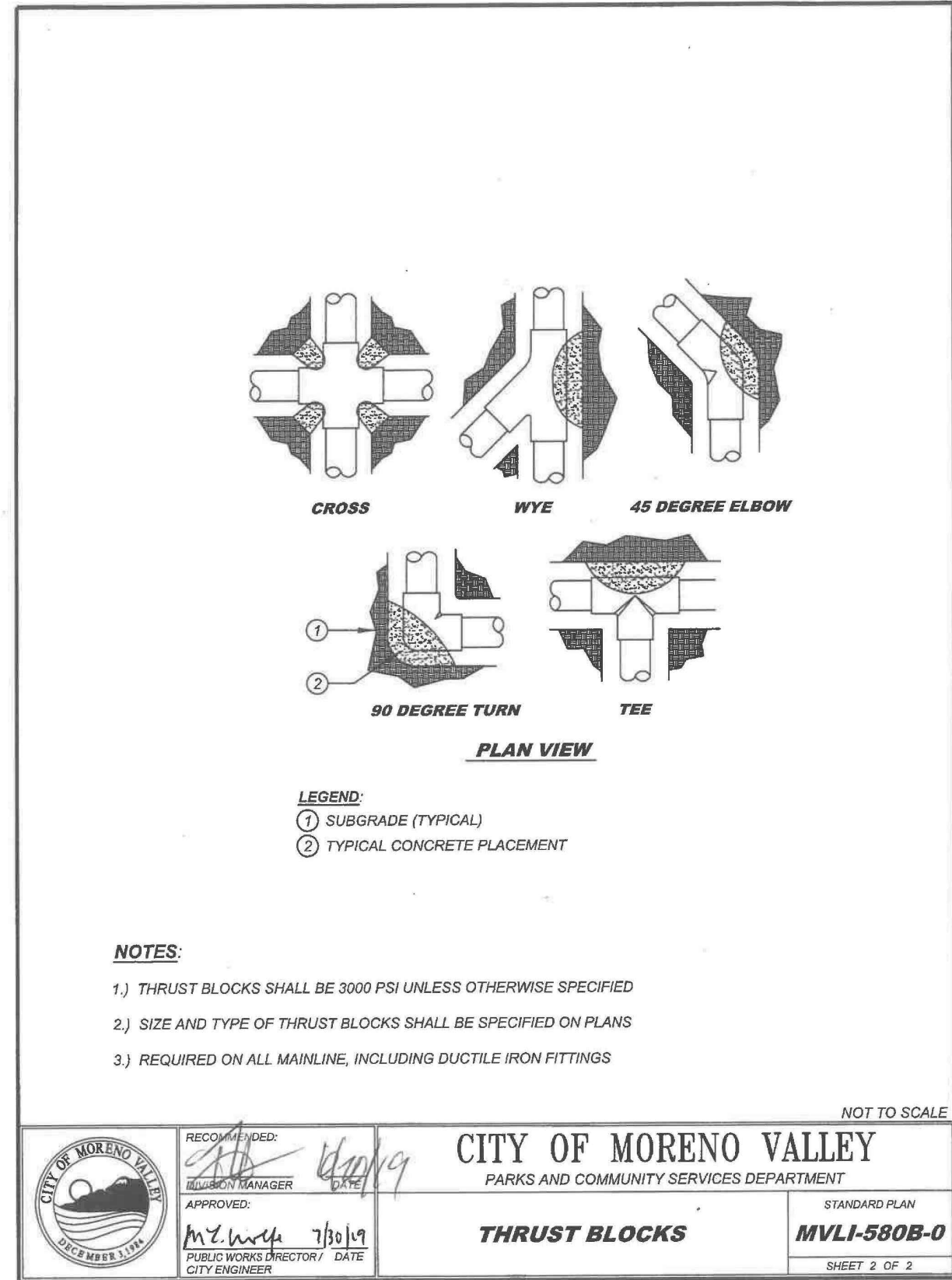

1

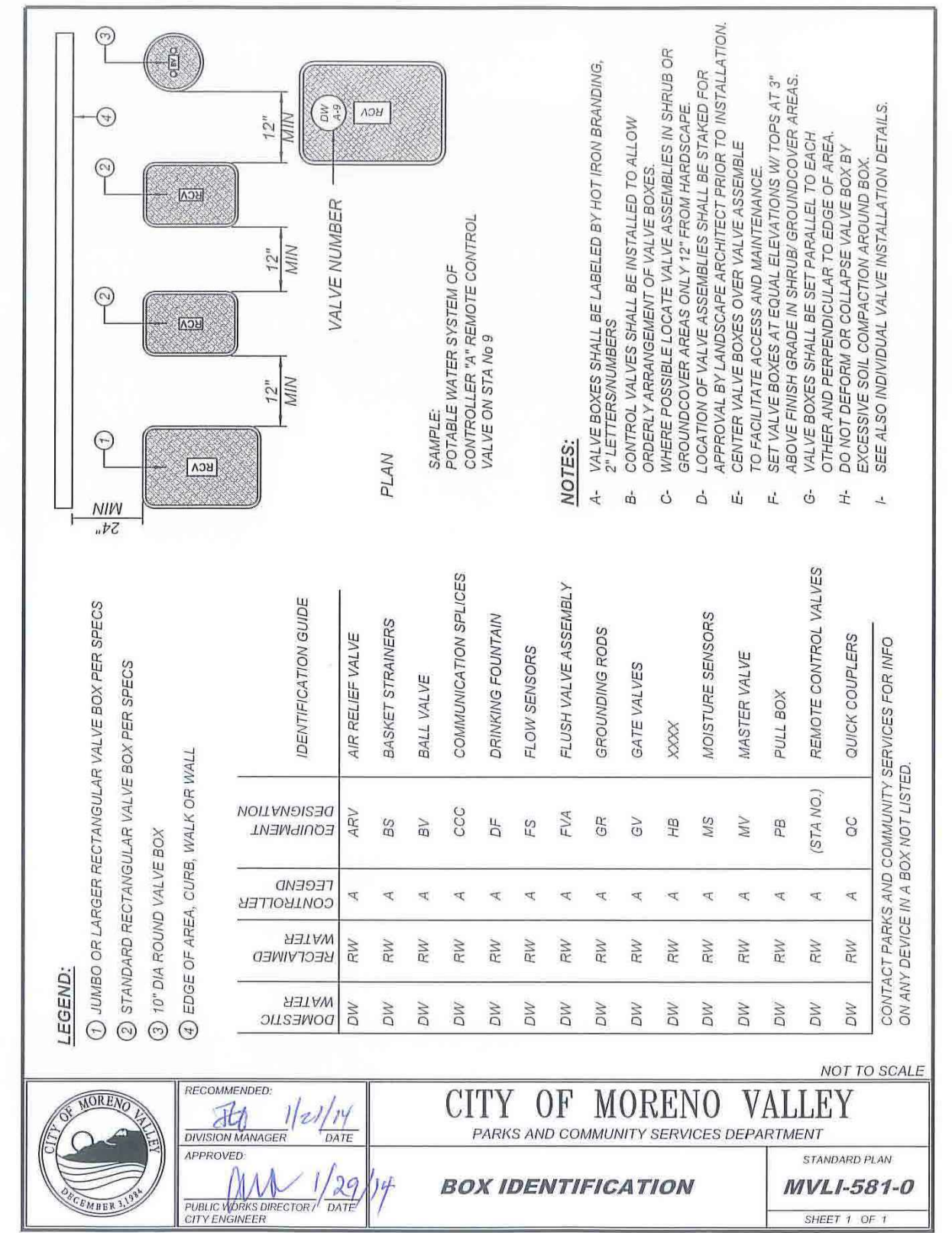

2

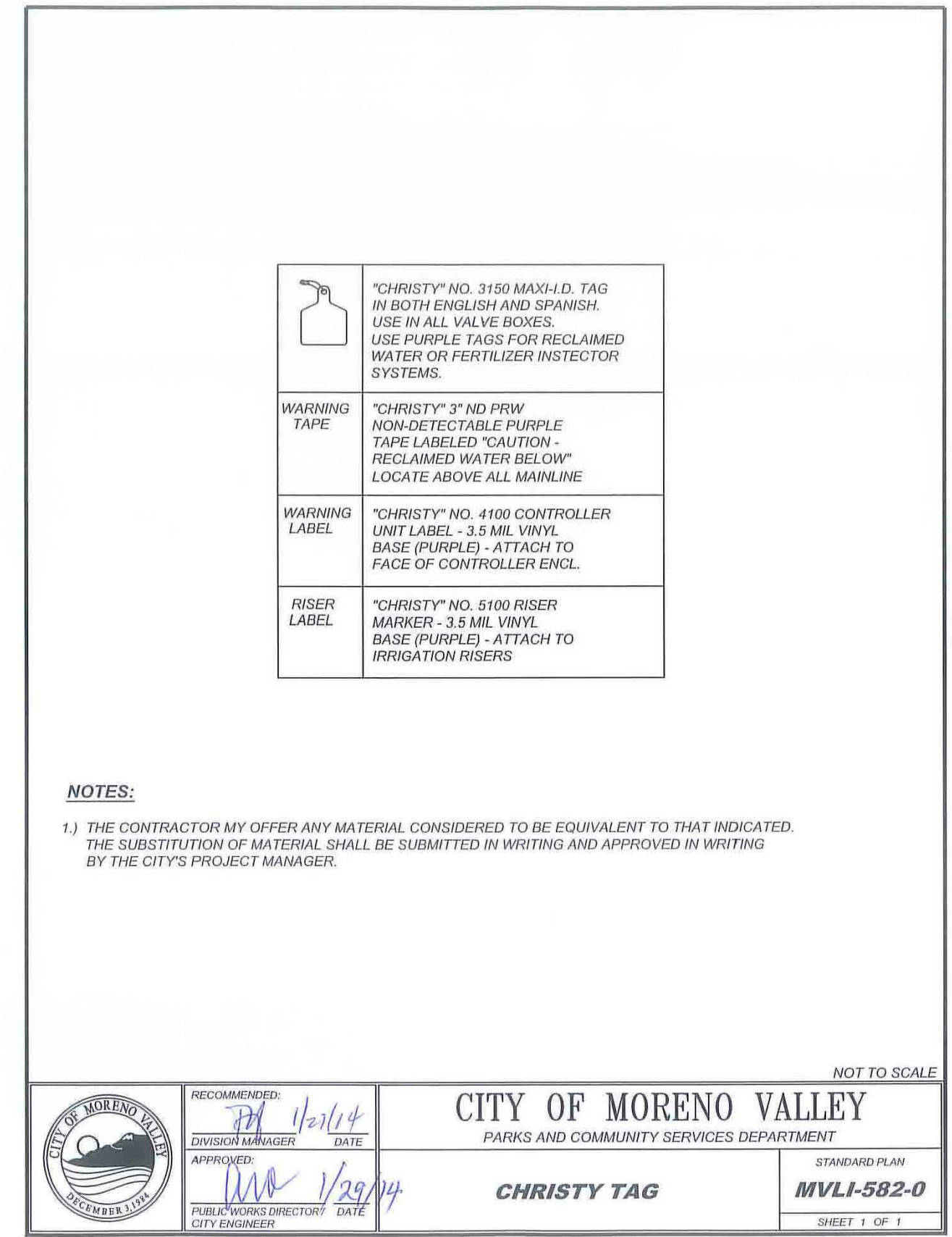

3

NO WORK SHALL BE DONE ON THIS SITE UNTIL BELOW AGENCY IS NOTIFIED OF INTENTION TO GRADE OR EXCAVATE.
 Underground Service Alert
 Call: TOLL FREE 811
 WWW.CALL811.COM
 TWO WORKING DAYS BEFORE YOU DIG

BASIS OF BEARING
 THE BASIS OF BEARINGS FOR THIS SURVEY IS THE CALIFORNIA STATE PLANE COORDINATE SYSTEM CCS83, ZONE 6, BASED LOCALLY ON CONTROL STATIONS "TR45", "TR47", AND "SBC0" NAD 83 (NAD 83) EPOCH 2010.00 AS SHOWN HEREON. ALL BEARINGS SHOWN ON THIS MAP ARE GRID. QUOTED BEARINGS AND DISTANCES FROM REFERENCE MAPS OR DEEDS ARE AS SHOWN PER THAT RECORD REFERENCE. ALL DISTANCES SHOWN ARE GROUND DISTANCES UNLESS SPECIFIED OTHERWISE. GRID DISTANCES MAY BE OBTAINED BY MULTIPLYING THE GROUND DISTANCE BY A COMBINATION FACTOR OF 0.99999579. CALCULATIONS ARE MADE AT TYPED "LS 5174", DOWN 0.2" IN WELL PER TRACT 36882, MB 454-07--39 WITH COORDINATES OF N: 22736.25500000, E: 6280431.21000000 USING AN ELEVATION OF 1665.533

REVIEW BY CITY STAFF		E.O.R.		REVISION	
OFFICE	INITIAL	DATE	NO.	DATE	INITIALS
ENGINEERING DIVISION MANAGER					
LAND DEVELOPMENT					
PLANNING					
TRANSPORTATION					
PARKS AND COMMUNITY SERVICES					
SPECIAL DISTRICTS					
STORM WATER MANAGEMENT PROGRAM					

DATE	APPR

LANDSCAPE ARCHITECT OF RECORD'S SEAL

PLANS PREPARED UNDER THE SUPERVISION OF:

SHANNON P. KARLSON
 R.L.A. #6070 (EXP. 10/31/23)
 DATE: 8/21/23

CITY OF MORENO VALLEY
 PUBLIC PARK IMPROVEMENT PLANS
 TRACT 38236
 STELLA PONTE & BELLA SERA
 IRRIGATION DETAILS

LID-5
 SHEET 19 OF 23
 CITY ID No: ---

TREE SCHEDULE					
TREES	BOTANICAL / COMMON NAME	SIZE	WUCOLS	QTY	REMARKS
	CERCIS OCCIDENTALIS WESTERN REDBUD	24"BOX	L	9	STANDARD
	LAGERSTROEMIA INDICA X FAURIEI 'NATCHEZ' NATCHEZ CRAPE MYRTLE	24"BOX	M	27	STANDARD
	MAGNOLIA GRANDIFLORA 'D.D. BLANCHARD' D.D. BLANCHARD SOUTHERN MAGNOLIA	36" BOX	M	6	STANDARD
	PLATANUS X ACERIFOLIA 'BLOODGOOD' BLOODGOOD LONDON PLANE TREE	36"BOX	M	12	STANDARD
	RHUS LANCEA AFRICAN SUMAC	24"BOX	L	16	STANDARD

- NOTES:
1. INSTALL ROOT BARRIER AROUND ANY TREES WITHIN 5' OF ANY HARDSCAPE AREA, WALL, BUILDING, OR ANY RIGHT-OF-WAY CONCRETE.
 2. PLANT QUANTITIES LISTED ARE FOR CONVENIENCE ONLY. THE ACTUAL NUMBER OF PLANTS SHOWN ON THE PLAN TAKE PRECEDENCE OVER QUANTITIES LISTED.
 3. ALL NON-TURF AREAS TO RECEIVE A 3" LAYER OF MEDIUM GRIND BARK MULCH UNDER SHRUBS AND 1-1/2" LAYER BARK MULCH AT GROUND COVER AREAS.
 4. MAINTAIN 5' FROM OVERHEAD UTILITIES, WALLS, BUILDINGS, AND STRUCTURES.
 5. ALL SHRUBS TO BE SPECIMEN QUALITY AND CONTAINER FULL.

SHRUB & GROUND COVER SCHEDULE					
SHRUBS	BOTANICAL / COMMON NAME	SIZE	WUCOLS	QTY	REMARKS
	AGAVE DESMETTIANA 'VARIEGATA' VARIEGATED DWARF SMOOTH AGAVE	5 GAL	L	51	SPECIMEN QUALITY
	ALOE STRIATA CORAL ALOE	1 GAL	L	64	SPECIMEN QUALITY
	BACCHARIS PILULARIS 'TWIN PEAKS' TWIN PEAKS COYOTE BRUSH	1 GAL	L	199	CONTAINER FULL
	CALLISTEMON CITRINUS 'LITTLE JOHN' DWARF BOTTLE BRUSH	5 GAL	L	66	CONTAINER FULL
	DIANELLA REVOLUTA 'LITTLE REV' LITTLE REV FLAX LILY	1 GAL	L	377	CONTAINER FULL
	DIANELLA TASMANICA 'SILVER STREAK' SILVER STREAK FLAX LILY	5 GAL	L	12	CONTAINER FULL
	HESPERALOE PARVIFLORA 'PERPA' BRAKELIGHTS RED YUCCA	1 GAL	L	91	CONTAINER FULL
	JUNIPERUS HORIZONTALIS 'BLUE CHIP' BLUE CHIP JUNIPER	1 GAL	L	94	CONTAINER FULL
	LANTANA MONTEVIDENSIS 'ALBA' WHITE TRAILING LANTANA	1 GAL	L	112	CONTAINER FULL
	OLEA EUROPAEA 'MONTRA' LITTLE OLLIE DWARF OLIVE	5 GAL	L	104	CONTAINER FULL
	ROSMARINUS OFFICINALIS 'HUNTINGTON CARPET' HUNTINGTON CARPET ROSEMARY	1 GAL	L	186	CONTAINER FULL
	ROSMARINUS OFFICINALIS 'TUSCAN BLUE' TUSCAN BLUE ROSEMARY	5 GAL	L	3	CONTAINER FULL
	SENECIO MANDRALISCAE BLUE FINGERS	1 GAL	L	273	CONTAINER FULL
VINES	BOTANICAL / COMMON NAME	SIZE	WUCOLS	QTY	REMARKS
	FICUS PUMILA CREEPING FIG	5 GAL @ 10' O.C.	M	41	CONTAINER FULL. ATTACH VINE TO WALL PER CITY STANDARD DETAIL.
GROUND COVERS	BOTANICAL / COMMON NAME	SIZE	WUCOLS	QTY	REMARKS
	BULL'S EYE BERMUDA	SOD	H	33,945 SF	FROM WEST COAST TURF

NO WORK SHALL BE DONE ON THIS SITE UNTIL BELOW AGENCY IS NOTIFIED OF INTENTION TO GRADE OR EXCAVATE.
 Underground Service Alert
 Call: TOLL FREE 811
 WWW.CALL811.COM
 TWO WORKING DAYS BEFORE YOU DIG

BASIS OF BEARING
 THE BASIS OF BEARINGS FOR THIS SURVEY IS THE CALIFORNIA STATE PLANE COORDINATE SYSTEM CCS83, ZONE 6, BASED LOCALLY ON CONTROL STATIONS "TR45", "TR47", AND "SBC0" NAD 83 (NSRS2011) EPOCH 2010.00 AS SHOWN HEREON. ALL BEARINGS SHOWN ON THIS MAP ARE GRID. QUOTED BEARINGS AND DISTANCES FROM REFERENCE MAPS OR DEEDS ARE, AS SHOWN PER THAT RECORD REFERENCE. ALL DISTANCES SHOWN ARE GROUND DISTANCES UNLESS SPECIFIED OTHERWISE. GRID DISTANCES MAY BE OBTAINED BY MULTIPLYING THE GROUND DISTANCE BY A COMBINATION FACTOR OF 0.99999579. CALCULATIONS ARE MADE AT TYP TAGGED "LS 5174", DOWN 0.2' IN WELL PER TRACT 36882, MB 454-07--09 WITH COORDINATES OF: N: 227736.255000000, E: 6280431.210000000 USING AN ELEVATION OF 1665.533

REVIEW BY CITY STAFF		E.O.R.		REVISION	
OFFICE	INITIAL	DATE	NO.	DATE	INITIALS
ENGINEERING DIVISION MANAGER					
LAND DEVELOPMENT					
PLANNING					
TRANSPORTATION					
PARKS AND COMMUNITY SERVICES					
SPECIAL DISTRICTS					
STORM WATER MANAGEMENT PROGRAM					

DATE	APPR

LANDSCAPE ARCHITECT OF RECORD'S SEAL

bmla
 LANDSCAPE ARCHITECTURE
 310 NORTH JOY STREET | CORONA, CA 92626
 TEL: 951-267-1124 | FAX: 951-267-6661

PLANS PREPARED UNDER THE SUPERVISION OF:

 SHANNON P. KARLSON
 R.L.A. #6070 (EXP. 10/31/23)

8/21/23
 DATE

CITY OF MORENO VALLEY

PUBLIC PARK IMPROVEMENT PLANS
 TRACT 38236
 STELLA POINTE & BELLA SERA

PLANTING SCHEDULES & NOTES

LPL-1
 SHEET 20 OF 23
 CITY ID No. ---

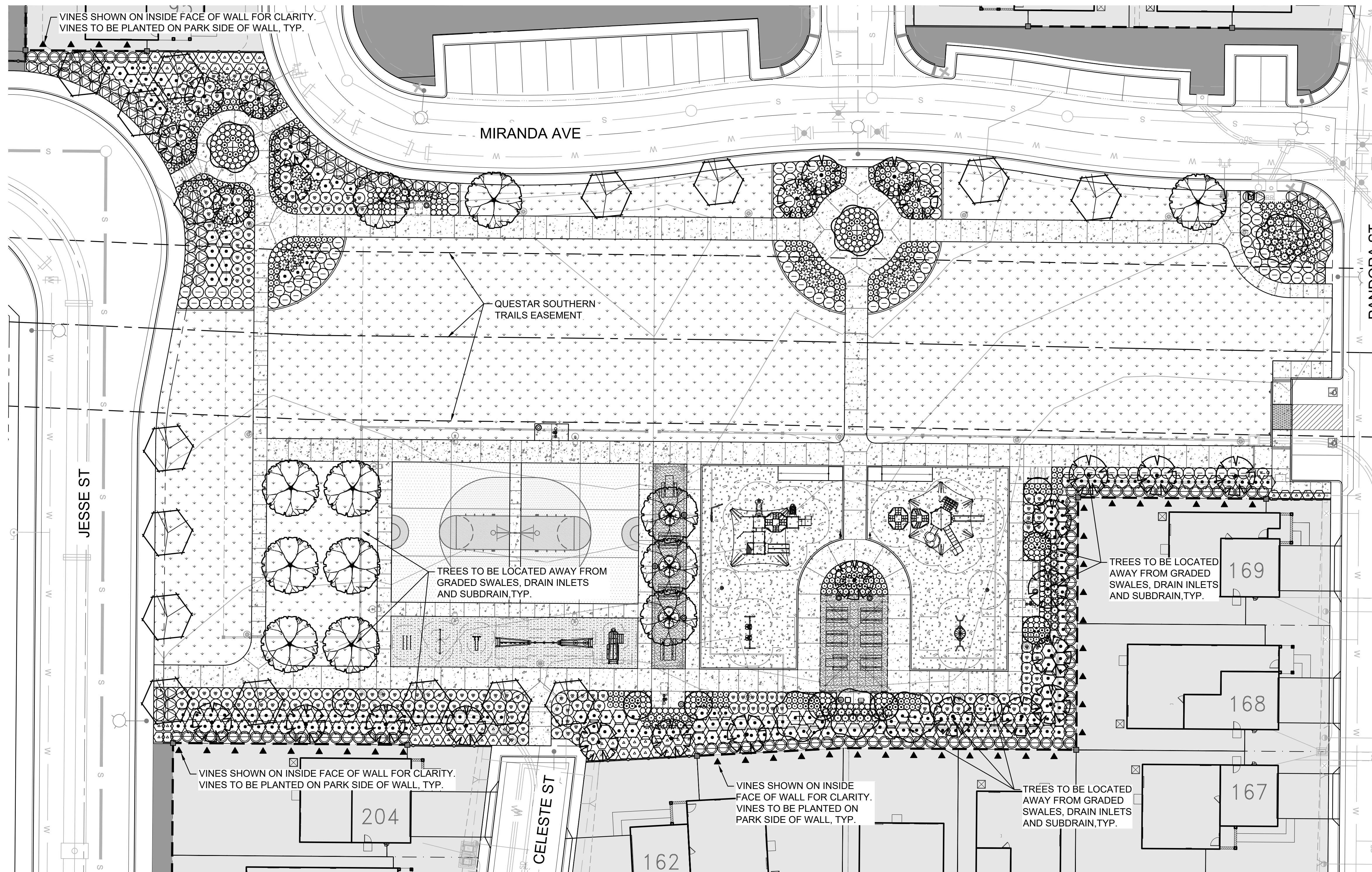

TREES	BOTANICAL / COMMON NAME	SIZE	WUCOLS
	CERCIS OCCIDENTALIS WESTERN REDBUD	24"BOX	L
	LAGERSTROEMIA INDICA X FAURIEI 'NATCHEZ' NATCHEZ CRAPE MYRTLE	24"BOX	M
	MAGNOLIA GRANDIFLORA 'D.D. BLANCHARD' D.D. BLANCHARD SOUTHERN MAGNOLIA	36" BOX	M
	PLATANUS X ACERIFOLIA 'BLOODGOOD' BLOODGOOD LONDON PLANE TREE	36"BOX	M
	RHUS LANCEA AFRICAN SUMAC	24"BOX	L

REFER TO SHEET LPL-1 FOR COMPLETE PLANTING SCHEDULES

- N.A.P.
REFER TO TFY & REAR YARD SLOPE PLANS PREPARED BY BMLA
- N.A.P.
REFER TO HOA PLANS PREPARED BY BMLA

REFER TO SHEET LPL-1 FOR PLANTING SCHEDULES AND NOTES.

NOTE: ALL ABOVE GROUND UTILITIES TO BE SCREENED WITH PLANT MATERIAL.

NOTE: ALL PLANTS TO BE REVIEWED WITH PHOTO SUBMITTALS PRIOR TO DELIVERY TO THE JOB SITE.

INDEX MAP NTS

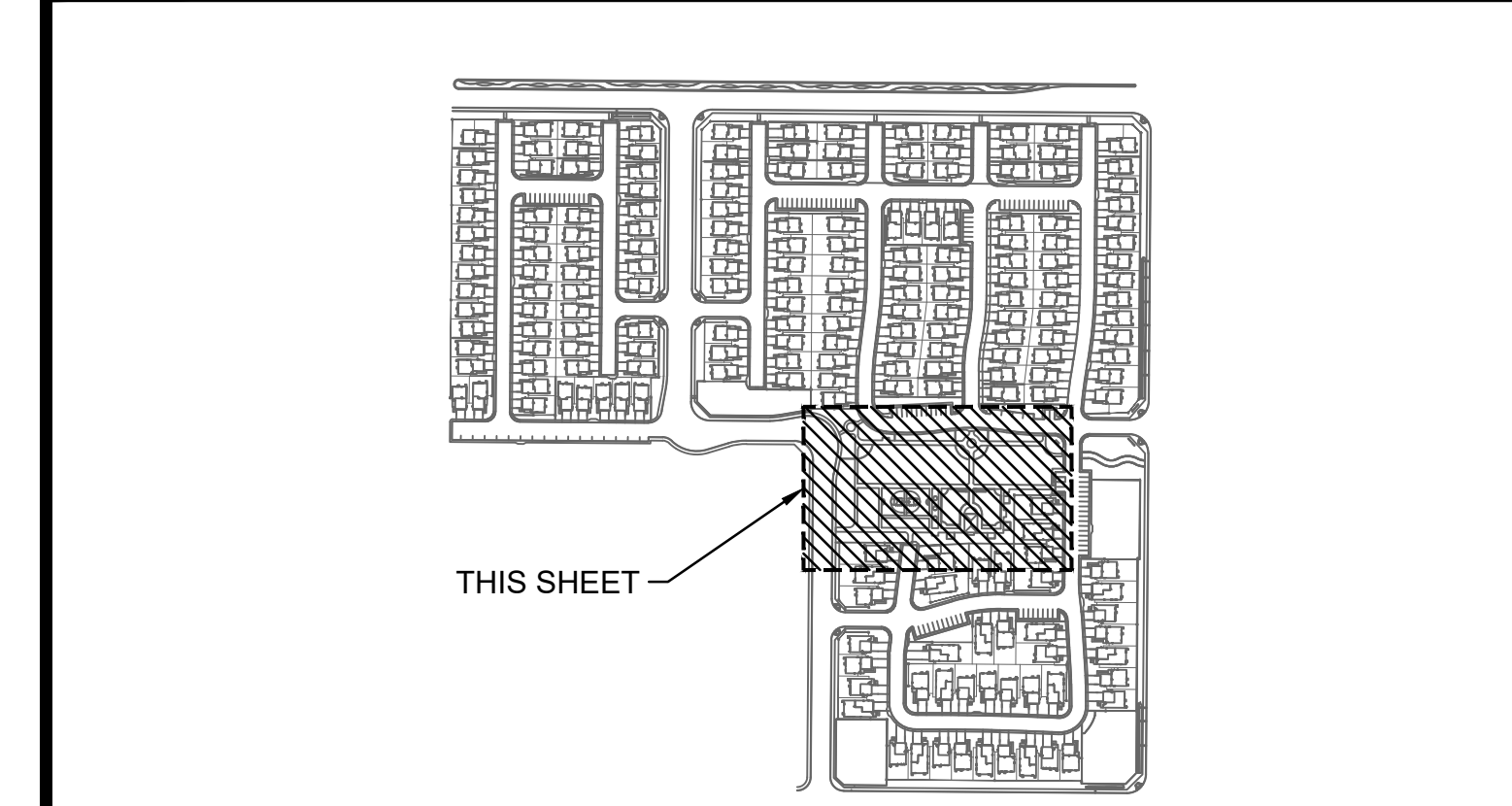

ELECTRICAL NOTE:
LIGHTING WIRING ROUTES ARE SHOWN DIAGRAMMATICALLY AND ANY WIRING SHALL BE LOCATED AWAY FROM TREE TRUNKS DURING FIELD INSTALLATION. ELECTRICAL CONTRACTOR TO CREATE A BUFFER FROM TREE TRUNK AND WIRING TO HAVE A MINIMUM 30" INSTALLATION CLEARANCE.

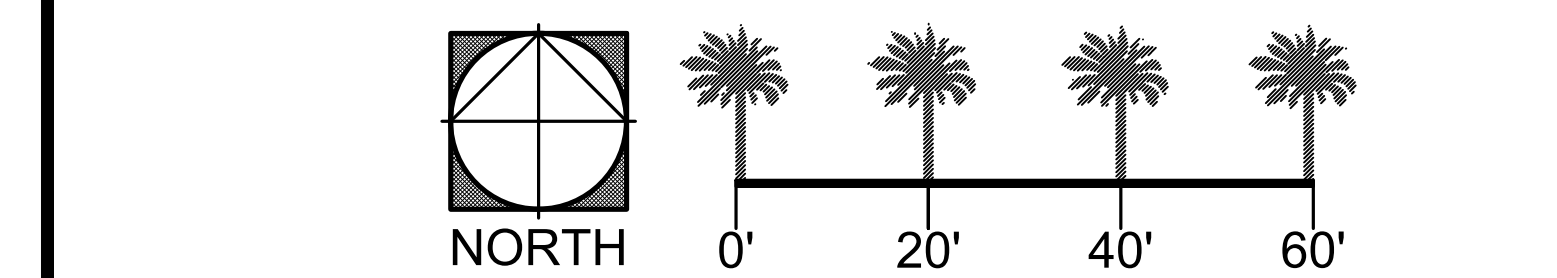

NO WORK SHALL BE DONE ON THIS SITE UNTIL BELOW AGENCY IS NOTIFIED OF INTENTION TO GRADE OR EXCAVATE.
Underground Service Alert
Call: TOLL FREE 811
WWW.CALL811.COM
TWO WORKING DAYS BEFORE YOU DIG

BASIS OF BEARING
THE BASIS OF BEARINGS FOR THIS SURVEY IS THE CALIFORNIA STATE PLANE COORDINATE SYSTEM CCS83, ZONE 6, BASED LOCALLY ON CONTROL STATIONS "1480", "1478", AND "1500" NAD 83 (NRSR2011) EPOCH 2010.00 AS SHOWN HEREON. ALL BEARINGS SHOWN ON THIS MAP ARE GRID. QUOTED BEARINGS AND DISTANCES FROM REFERENCE MAPS OR DEEDS ARE, AS SHOWN PER THAT RECORD REFERENCE. ALL DISTANCES SHOWN ARE GROUND DISTANCES UNLESS SPECIFIED OTHERWISE. GRID DISTANCES MAY BE OBTAINED BY MULTIPLYING THE GROUND DISTANCE BY A COMBINATION FACTOR OF 0.99999379. CALCULATIONS ARE MADE AT TYP TAGGED "LS 5174", DOWN 0.2' IN WELL PER TRACT 36882, MB 454-07--39 WITH COORDINATES OF: N: 227736.255000000, E: 6280431.210000000 USING AN ELEVATION OF 1665.533

REVIEW BY CITY STAFF		E.O.R.		REVISION	
OFFICE	INITIAL	DATE	NO.	DATE	INITIALS
ENGINEERING DIVISION MANAGER					
LAND DEVELOPMENT					
PLANNING					
TRANSPORTATION					
PARKS AND COMMUNITY SERVICES					
SPECIAL DISTRICTS					
STORM WATER MANAGEMENT PROGRAM					

LANDSCAPE ARCHITECT OF RECORD'S SEAL

bmla
LANDSCAPE ARCHITECTURE
310 NORTH JOY STREET | CORONA, CA 92620
TEL: 951.267.1294 | FAX: 951.267.6691
PLANS PREPARED UNDER THE SUPERVISION OF:

SHANNON P. KARLSON
R.L.A. #6070 (EXP. 10/31/23)
8/21/23
DATE

CITY OF MORENO VALLEY
PUBLIC PARK IMPROVEMENT PLANS
TRACT 38236
STELLA POINTE & BELLA SERA
PLANTING PLAN

LP-1
SHEET 21 OF 23
CITY ID No. ---

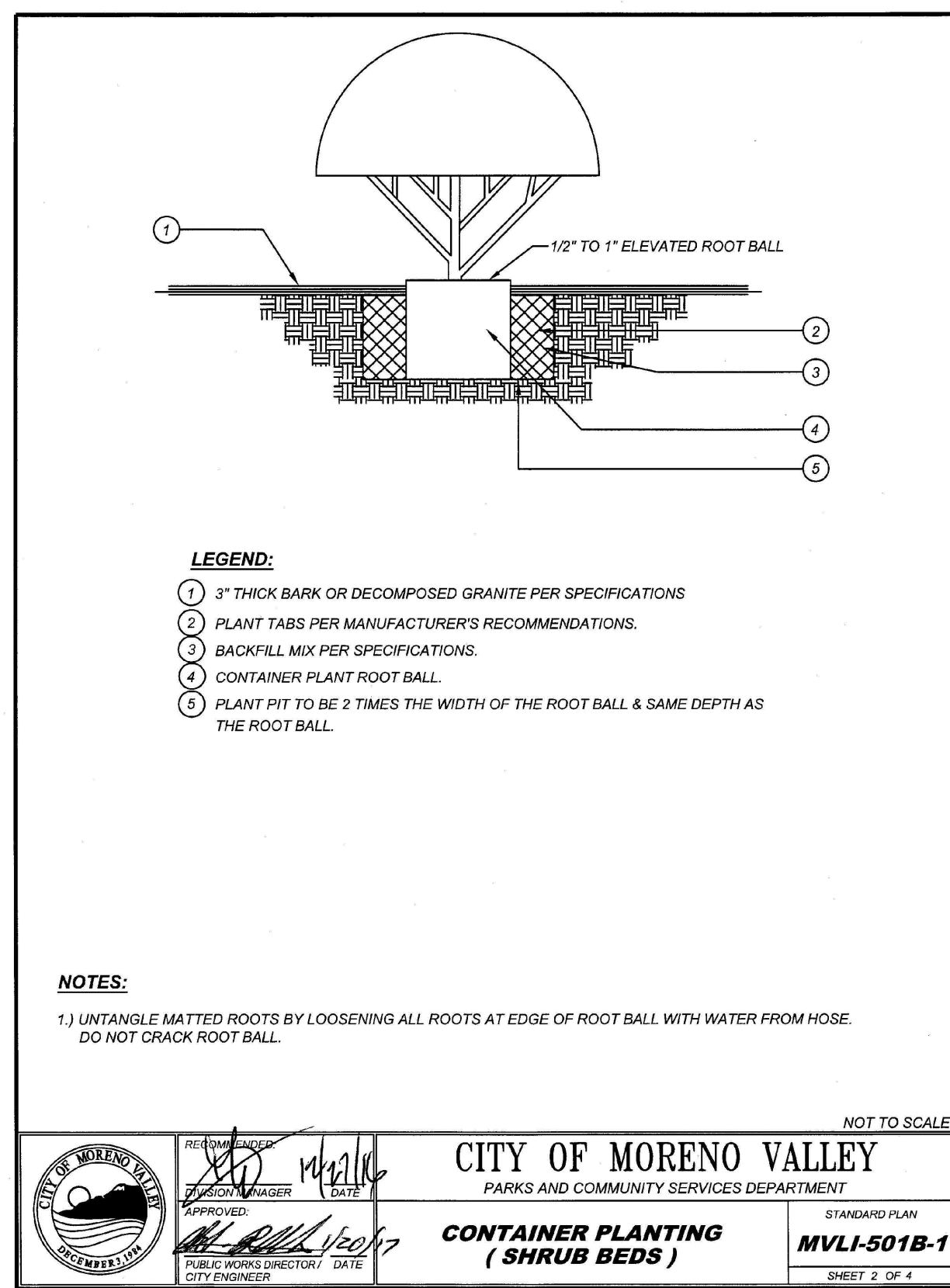

- LEGEND:**
- 1) 3\"/>

NOTES:

- 1) UNFANGLE MATTED ROOTS BY LOOSENING ALL ROOTS AT EDGE OF ROOT BALL WITH WATER FROM HOSE. DO NOT CRACK ROOT BALL.

NOT TO SCALE

CITY OF MORENO VALLEY
PARKS AND COMMUNITY SERVICES DEPARTMENT

CONTAINER PLANTING (SHRUB BEDS) **MVLI-501B-1**
STANDARD PLAN SHEET 2 OF 4

1

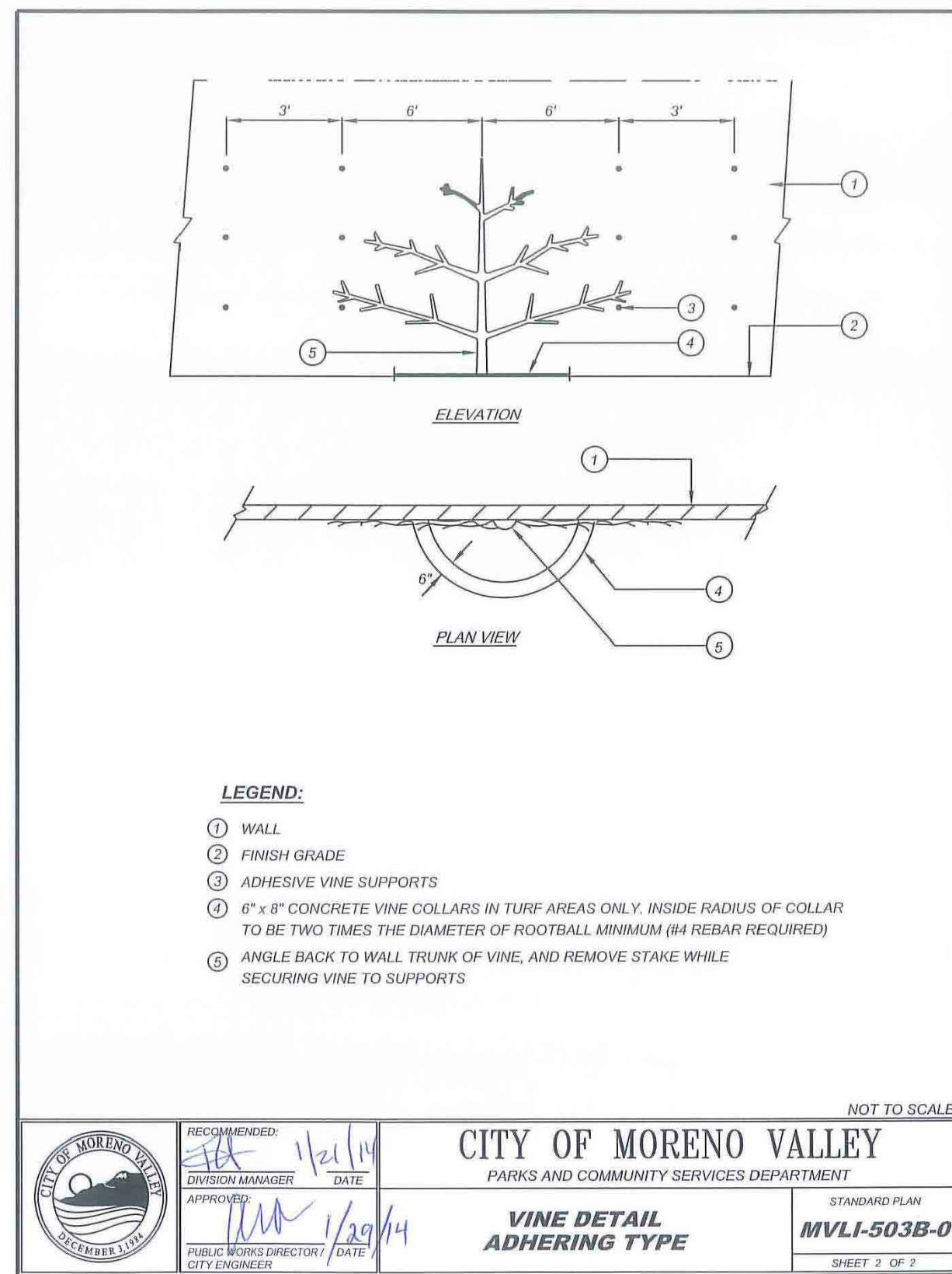

- LEGEND:**
- 1) WALL
 - 2) FINISH GRADE
 - 3) ADHESIVE VINE SUPPORTS
 - 4) 6\"/>

NOTES:

- 1) ALL SHRUBS / GROUND COVER TO BE PLANTED AT EQUAL SPACING (TRIANGULAR) UNLESS OTHERWISE INDICATED ON PLANS. SEE LEGEND FOR SPACING REQUIREMENTS.

NOT TO SCALE

CITY OF MORENO VALLEY
PARKS AND COMMUNITY SERVICES DEPARTMENT

VINE DETAIL ADHERING TYPE **MVLI-503B-0**
STANDARD PLAN SHEET 2 OF 2

2

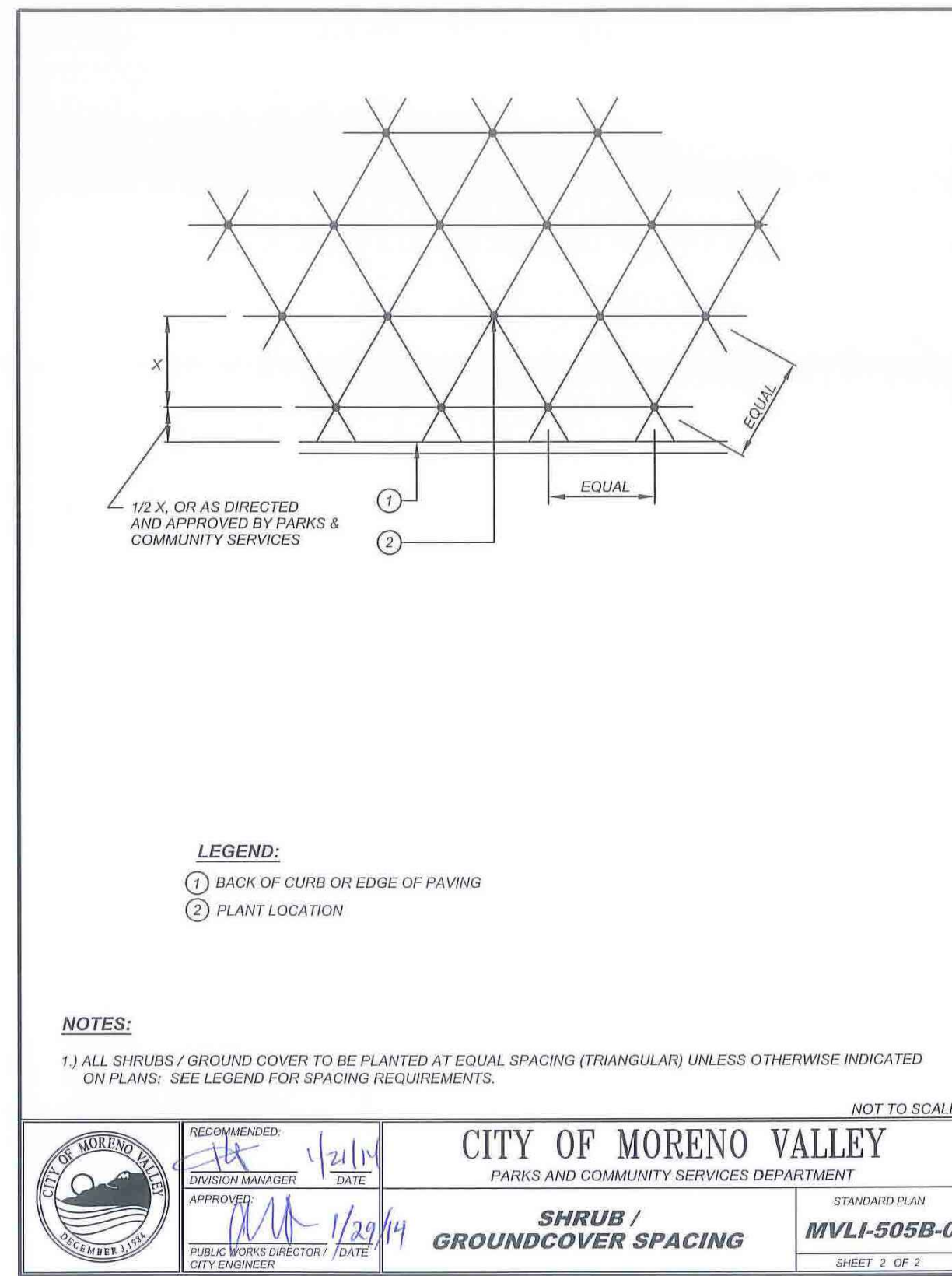

- LEGEND:**
- 1) BACK OF CURB OR EDGE OF PAVING
 - 2) PLANT LOCATION

NOTES:

- 1) ALL SHRUBS / GROUND COVER TO BE PLANTED AT EQUAL SPACING (TRIANGULAR) UNLESS OTHERWISE INDICATED ON PLANS. SEE LEGEND FOR SPACING REQUIREMENTS.

NOT TO SCALE

CITY OF MORENO VALLEY
PARKS AND COMMUNITY SERVICES DEPARTMENT

SHRUB / GROUND COVER SPACING **MVLI-505B-0**
STANDARD PLAN SHEET 2 OF 2

3

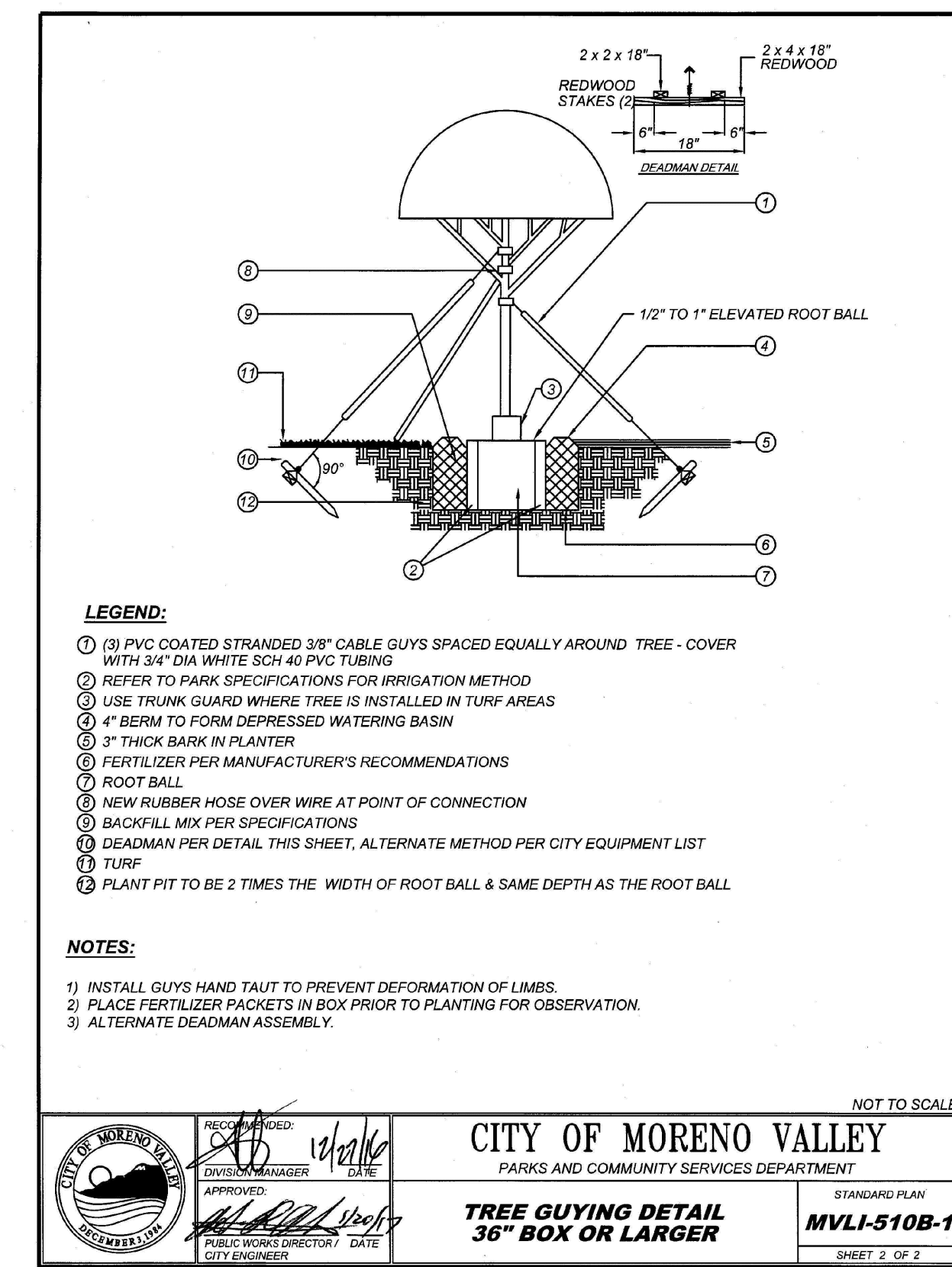

- LEGEND:**
- 1) (8) PVC COATED STRANDED 3/8\"/>

NOTES:

- 1) INSTALL GUYS HAND TAUT TO PREVENT DEFORMATION OF LIMBS.
- 2) PLACE FERTILIZER PACKETS IN BOX PRIOR TO PLANTING FOR OBSERVATION.
- 3) ALTERNATE DEADMAN ASSEMBLY.

NOT TO SCALE

CITY OF MORENO VALLEY
PARKS AND COMMUNITY SERVICES DEPARTMENT

TREE GUYING DETAIL 36\"/>

4

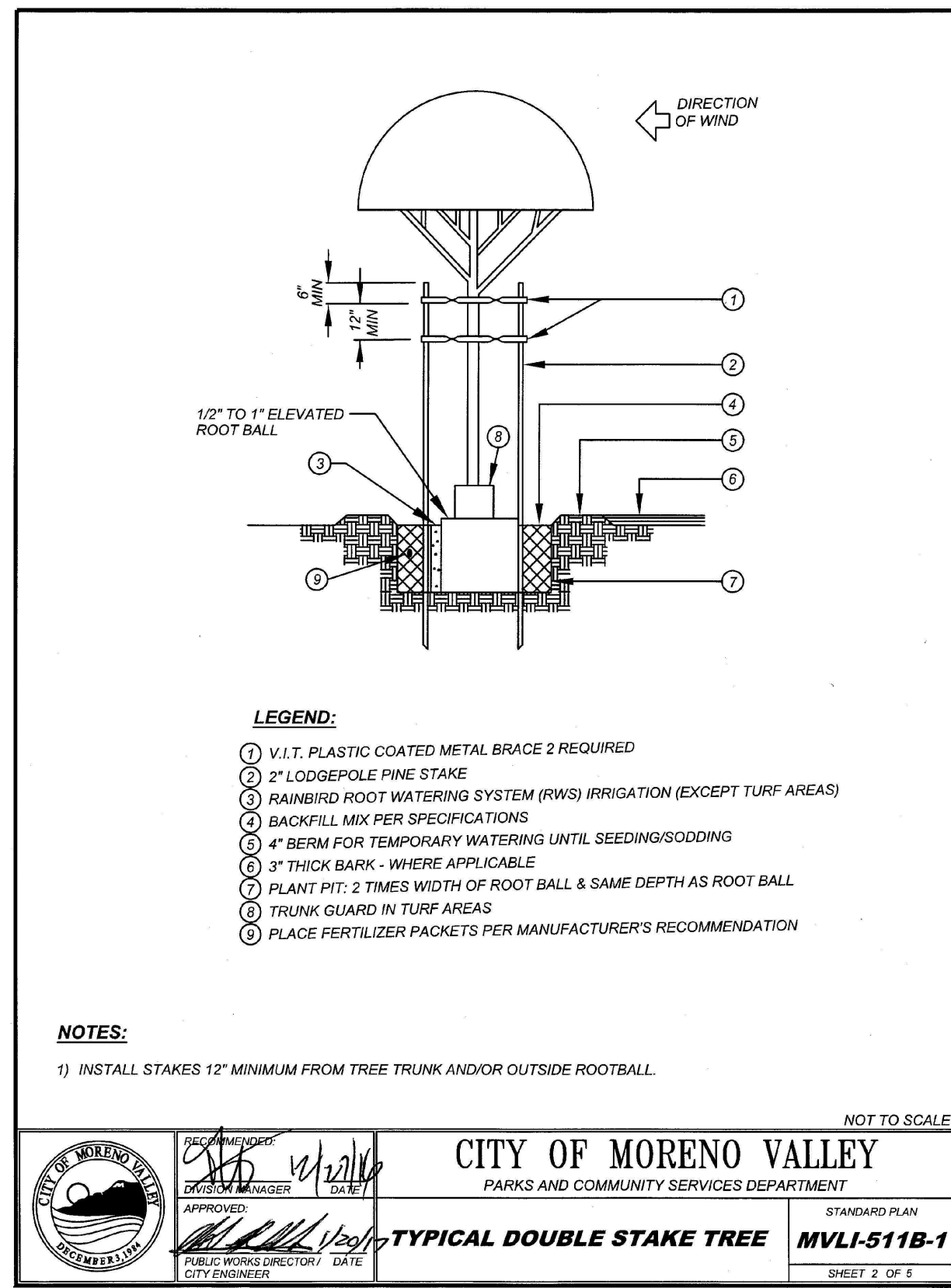

- LEGEND:**
- 1) V.I.T. PLASTIC COATED METAL BRACE 2 REQUIRED
 - 2) 2\"/>

NOTES:

- 1) INSTALL STAKES 12\"/>

NOT TO SCALE

CITY OF MORENO VALLEY
PARKS AND COMMUNITY SERVICES DEPARTMENT

TYPICAL DOUBLE STAKE TREE **MVLI-511B-1**
STANDARD PLAN SHEET 2 OF 2

5

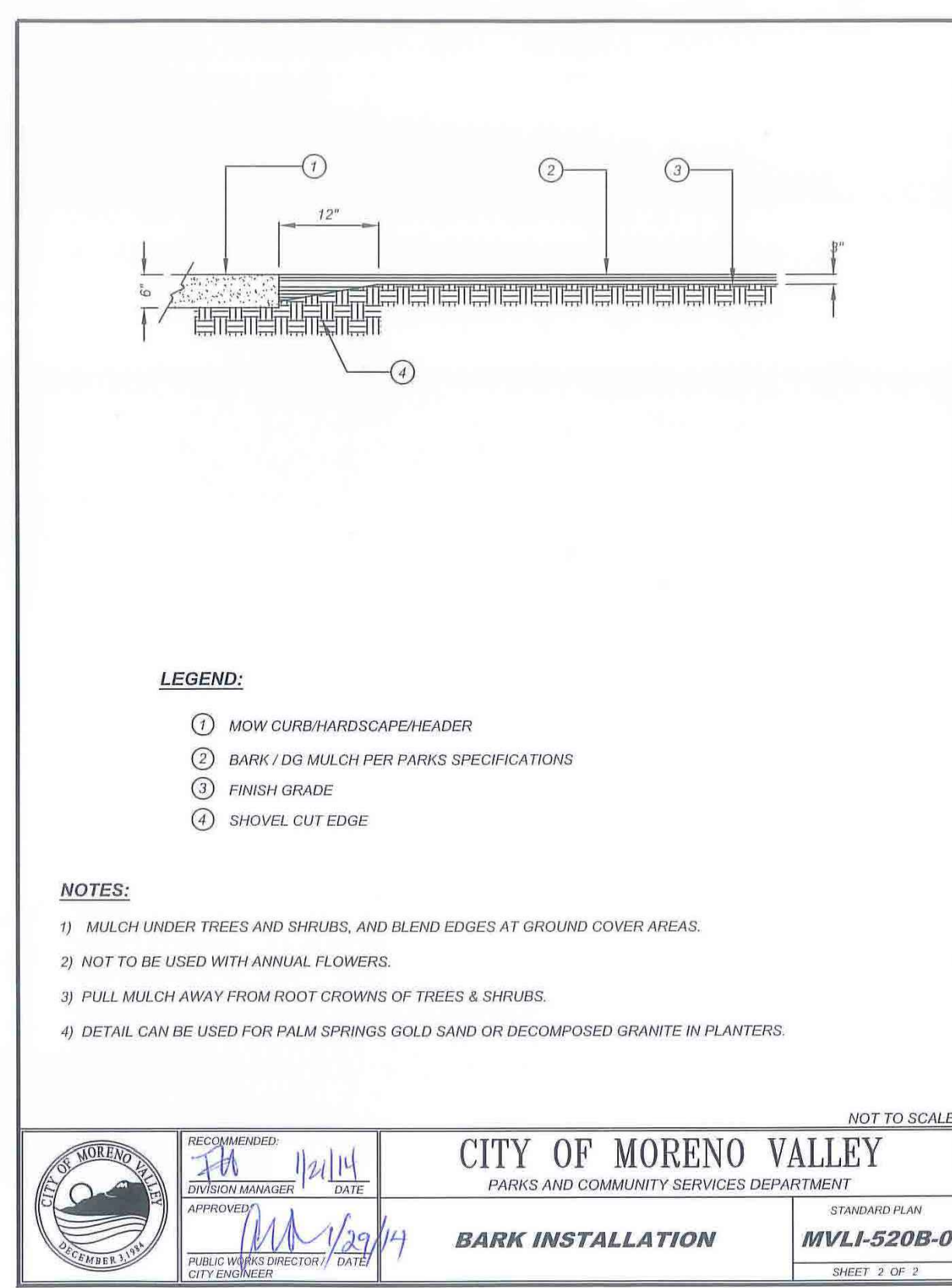

- LEGEND:**
- 1) MOW CURB/HARDSCAPE/HEADER
 - 2) BARK / DG MULCH PER PARKS SPECIFICATIONS
 - 3) FINISH GRADE
 - 4) SHOVEL CUT EDGE

NOTES:

- 1) MULCH UNDER TREES AND SHRUBS, AND BLEND EDGES AT GROUND COVER AREAS.
- 2) NOT TO BE USED WITH ANNUAL FLOWERS.
- 3) PULL MULCH AWAY FROM ROOT CROWNS OF TREES & SHRUBS.
- 4) DETAIL CAN BE USED FOR PALM SPRINGS GOLD SAND OR DECOMPOSED GRANITE IN PLANTERS.

NOT TO SCALE

CITY OF MORENO VALLEY
PARKS AND COMMUNITY SERVICES DEPARTMENT

BARK INSTALLATION **MVLI-520B-0**
STANDARD PLAN SHEET 2 OF 2

6

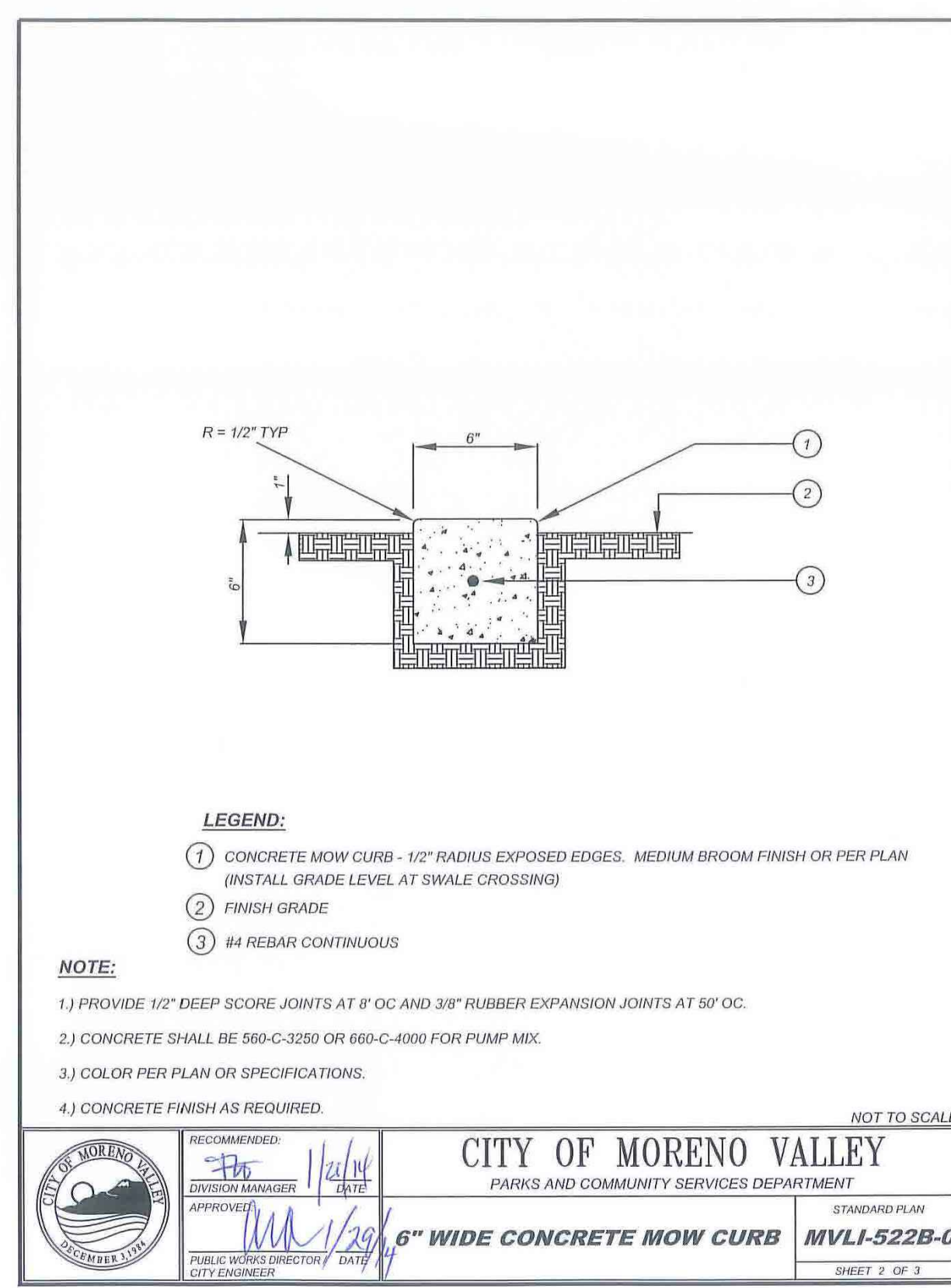

- LEGEND:**
- 1) CONCRETE MOW CURB - 1/2\"/>

NOTE:

- 1) PROVIDE 1/2\"/>

NOT TO SCALE

CITY OF MORENO VALLEY
PARKS AND COMMUNITY SERVICES DEPARTMENT

6\"/>

7

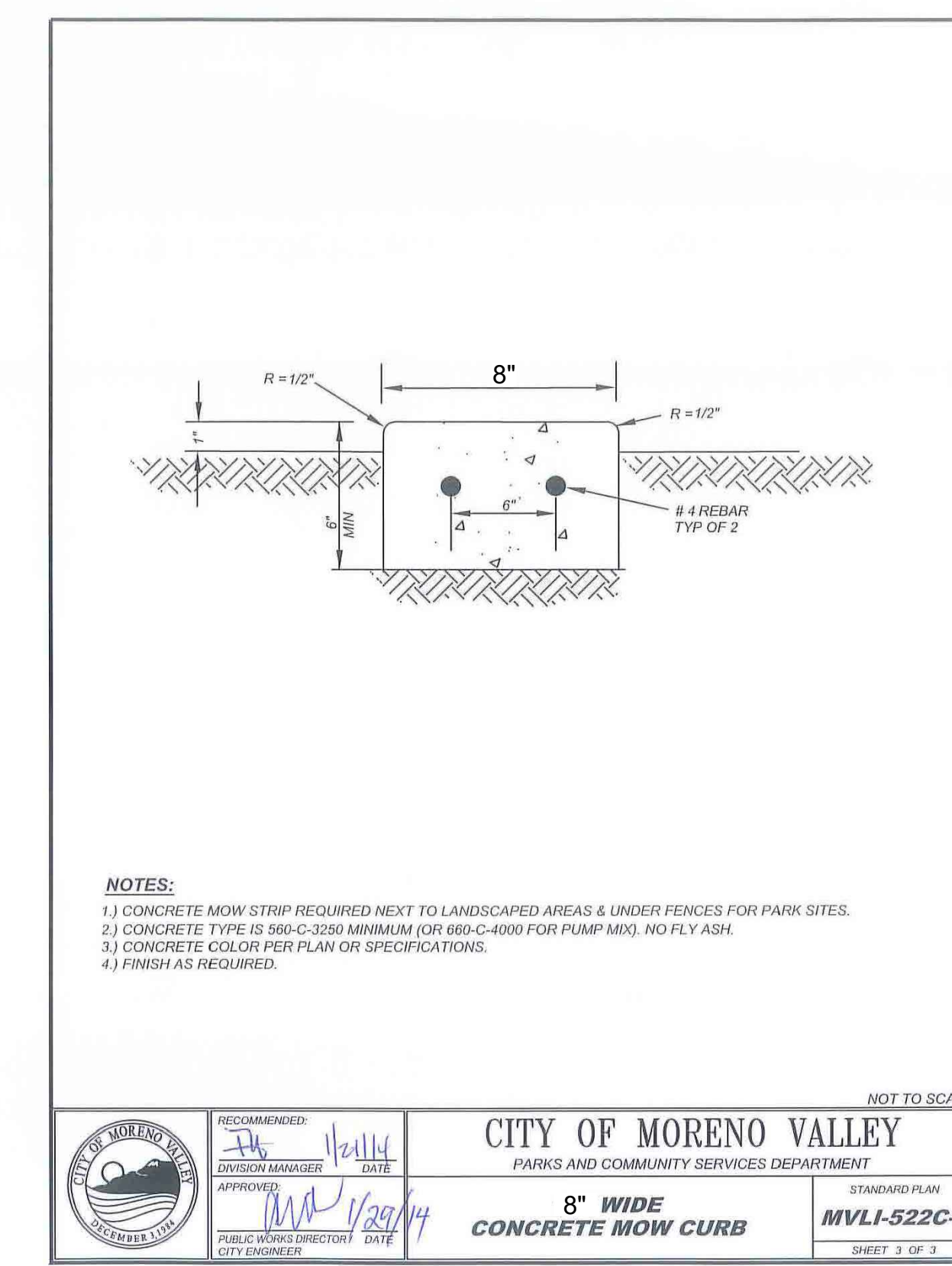

- NOTES:**
- 1) CONCRETE MOW STRIP REQUIRED NEXT TO LANDSCAPED AREAS & UNDER FENCES FOR PARK SITES.
 - 2) CONCRETE TYPE IS 500-C-3250 MINIMUM (OR 600-C-4000 FOR PUMP MIX), NO FLY ASH.
 - 3) CONCRETE COLOR PER PLAN OR SPECIFICATIONS.
 - 4) FINISH AS REQUIRED.

NOT TO SCALE

CITY OF MORENO VALLEY
PARKS AND COMMUNITY SERVICES DEPARTMENT

8\"/>

8

NO WORK SHALL BE DONE ON THIS SITE UNTIL BELOW AGENCY IS NOTIFIED OF INTENTION TO GRADE OR EXCAVATE.

Underground Service Alert
Call: TOLL FREE 811

WWW.CALL811.COM
TWO WORKING DAYS BEFORE YOU DIG

BASIS OF BEARING		REVIEW BY CITY STAFF		E.O.R.		REVISION	
OFFICE	INITIAL	DATE	NO.	DATE	INITIALS	DESCRIPTION	DATE
ENGINEERING DIVISION MANAGER							
LAND DEVELOPMENT							
PLANNING							
TRANSPORTATION							
PARKS AND COMMUNITY SERVICES							
SPECIAL DISTRICTS							
STORM WATER MANAGEMENT PROGRAM							

DATE	INITIALS	DESCRIPTION

LANDSCAPE ARCHITECT OF RECORD'S SEAL

REGISTERED LANDSCAPE ARCHITECT
SHANNON P. KARLSON
R.L.A. #6070 (EXP. 10/31/23)

bmla
LANDSCAPE ARCHITECTURE
310 NORTH JOY STREET | CORONA, CA 92626
TEL: 951.267.1124 | FAX: 951.267.6667

PLANS PREPARED UNDER THE SUPERVISION OF:

Shannon P. Karlson
SHANNON P. KARLSON
R.L.A. #6070 (EXP. 10/31/23)

8/21/23
DATE

CITY OF MORENO VALLEY

PUBLIC PARK IMPROVEMENT PLANS
TRACT 38236
STELLA PONTE & BELLA SERA

PLANTING DETAILS

LPD-1

SHEET 22 OF 23

CITY ID No. ---

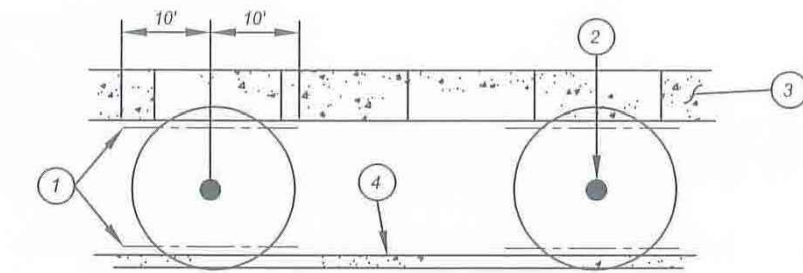

PLAN

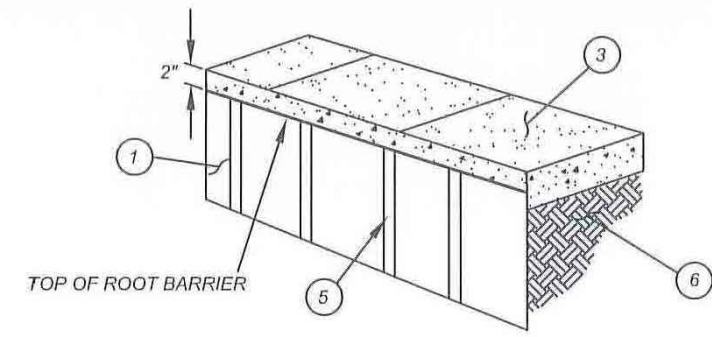

ELEVATION

LEGEND:

- ① 2" DEEP LINEAR ROOT BARRIER (PER PLAN AS SPECIFIED). INSTALL IN TRENCH WITH VERTICAL RIBS FACING TOWARDS THE TREE. TOP OF BARRIER TO EXTEND TO TOP OF CURB OR WALK, OR 1" ABOVE FINISH GRADE.
- ② TREE TRUNK LOCATION.
- ③ CONCRETE SIDEWALK OR SLAB.
- ④ CONCRETE CURB OR SITE WALL.
- ⑤ VERTICAL RIBS.
- ⑥ COMPACTED SUBGRADE.

NOT TO SCALE

	RECOMMENDED BY J. V. LOPEZ DIVISION MANAGER DATE: 1/22/14	CITY OF MORENO VALLEY PARKS AND COMMUNITY SERVICES DEPARTMENT STANDARD PLAN LINEAR ROOT BARRIER MVLI-524B-0 SHEET 2 OF 2
	APPROVED BY M. J. ... PUBLIC WORKS/CONSTRUCTION DIVISION CITY ENGINEER	

1

NO WORK SHALL BE DONE ON THIS SITE UNTIL BELOW AGENCY IS NOTIFIED OF INTENTION TO GRADE OR EXCAVATE.
 Underground Service Alert
 Call: TOLL FREE 811
 WWW.CALL811.COM
 TWO WORKING DAYS BEFORE YOU DIG

BASIS OF BEARING
 THE BASIS OF BEARINGS FOR THIS SURVEY IS THE CALIFORNIA STATE PLANE COORDINATE SYSTEM CCS83, ZONE 6, BASED LOCALLY ON CONTROL STATIONS "1485", "1478", AND "5800" NAD 83 (NAD83/2011) EPOCH 2010.00 AS SHOWN HEREON. ALL BEARINGS SHOWN ON THIS MAP ARE GRID. QUOTED BEARINGS AND DISTANCES FROM REFERENCE MAPS OR DEEDS ARE, AS SHOWN PER THAT RECORD REFERENCE. ALL DISTANCES SHOWN ARE GROUND DISTANCES UNLESS SPECIFIED OTHERWISE. GRID DISTANCES MAY BE OBTAINED BY MULTIPLYING THE GROUND DISTANCE BY A COMBINATION FACTOR OF 0.999993579. CALCULATIONS ARE MADE AT TYP TAGGED "LS 5174", DOWN 0.2' IN WELL PER TRACT 36882, MB 454/07-09 WITH COORDINATES OF N: 227736.255000000, E: 6280431.210000000 USING AN ELEVATION OF 1665.533

REVIEW BY CITY STAFF		E.O.R.	REVISION	DATE	APPR
OFFICE	INITIAL	DATE	NO.	DATE	INITIALS
ENGINEERING DIVISION MANAGER					
LAND DEVELOPMENT					
PLANNING					
TRANSPORTATION					
PARKS AND COMMUNITY SERVICES					
SPECIAL DISTRICTS					
STORM WATER MANAGEMENT PROGRAM					



LANDSCAPE ARCHITECT OF RECORD'S SEAL

bmla
 LANDSCAPE ARCHITECTURE
 310 NORTH JOY STREET | CORONA, CA 92620
 TEL: 951.267.1124 | FAX: 951.267.6667

PLANS PREPARED UNDER THE SUPERVISION OF:

 SHANNON P. KARLSON
 R.L.A. #6070 (EXP. 10/31/23)

8/21/23
 DATE

CITY OF MORENO VALLEY

PUBLIC PARK IMPROVEMENT PLANS
 TRACT 38236
 STELLA POINTE & BELLA SERA
 PLANTING DETAILS

LPD-2
 SHEET 23 OF 23
 CITY ID No: ---

GENERAL NOTES

- 1. THESE PLANS ARE DIAGRAMMATIC ONLY. FOLLOW AS CLOSELY AS POSSIBLE. REFER TO ARCHITECTURAL DRAWINGS FOR DETAILS, STRUCTURAL DETAILS, EXACT EQUIPMENT AND OUTLET LOCATIONS.
2. DO NOT SCALE THE ELECTRICAL DRAWINGS FOR LOCATIONS OF ANY ELECTRICAL DEVICES OR EQUIPMENT.
3. CONSTRUCTION TERMINOLOGY, AND THE STANDARDS OF INSTALLATION REQUIRED BY THESE CONTRACTOR DOCUMENTS ARE BASED ON PUBLISHED STANDARDS OF N.E.C.A. (NATIONAL ELECTRICAL CONTRACTORS ASSOCIATION), NATIONAL ELECTRICAL SAFETY CODE, AMERICAN NATIONAL STANDARDS INSTITUTE DOCUMENTS, NATIONAL ELECTRICAL MANUFACTURERS ASSOCIATION, UNDERWRITERS LABORATORIES, 201 6 CALIFORNIA ELECTRICAL CODE, 2016 CALIFORNIA BUILDING CODE, 201 6 CALIFORNIA MECHANICAL CODE SUBMITTAL OF BID INDICATES THE CONTRACTOR IS FAMILIAR OF THESE STANDARDS AND THE REQUIREMENTS NECESSARY TO PERFORM ALL THE WORK AS SET FORTH IN THESE CONTRACT DOCUMENTS AND ACCEPTS THE CONDITIONS.
4. CONTRACTOR SHALL VERIFY EXISTING SITE CONDITIONS, SERVICE REQUIREMENTS AND EXACT LOCATIONS OF SERVICE FACILITIES BEFORE SUBMITTING BID. SUBMITTAL OF BID INDICATES CONTRACTOR ACCEPTS THE CONDITIONS UNDER WHICH HE SHALL BE REQUIRED TO PERFORM HIS WORK.
5. ALL UTILITY WORK SHALL BE IN COMPLIANCE WITH THESE DRAWINGS AND THE REQUIREMENTS OF THE SERVING UTILITY COMPANY. IT SHALL BE THE CONTRACTOR'S RESPONSIBILITY TO CONTACT THE SERVING UTILITY TO RECEIVE COMPLETE INFORMATION ON THEIR REQUIREMENTS PRIOR TO THE SUBMISSION OF THE BID. THE ACT OF SUBMITTING THE BID SHALL CONSTITUTE ACCEPTANCE OF FULL RESPONSIBILITY BY THE CONTRACTOR TO INSTALL SERVICE IN COMPLIANCE WITH THE SERVING UTILITY AND THESE CONTRACT DOCUMENTS.
6. THE CONTRACTOR SHALL INSTALL THE SERVICE IN COMPLIANCE WITH THE SERVING UTILITY COMPANY, AND SHALL PAY ALL CHARGES LEVIED BY THE SERVING UTILITY COMPANY FOR HIS SERVICE EXCEPT THE FIRST BILLING DEPOSIT. WHERE THE CONTRACT DOCUMENTS ARE MORE RESTRICTIVE, THE DOCUMENTS SHALL GOVERN. ALL ITEMS SUCH AS SERVICE CONDUIT, CONDUCTORS, DUCTS, CONCRETE PADS, TRANSFORMERS, RISERS, MANHOLES, PULL BOXES, AND PROTECTIVE COVERING FROM SERVICE LOCATION SHALL BE INSTALLED AND VERIFIED WITH THE SERVING UTILITY COMPANY.
7. ELECTRICAL CONTRACTOR SHALL PAY FOR AND SECURE ALL NECESSARY BUILDING PERMITS, UTILITY COMPANY CHARGES. IF REQUIRED, CONTRACTOR SHALL COORDINATE AND PAY FOR ALL TEMPORARY ELECTRICAL SERVICE CHARGES WITH THE BUILDING DEPARTMENT, SERVING UTILITY, AND OWNER.
8. SUBMIT SHOP DRAWINGS FOR ALL MAJOR PIECES OF ELECTRICAL EQUIPMENT, WHICH INCLUDES, BUT NOT LIMITED TO: PEDESTAL LIGHTING FIXTURES, CONTROL PANELS, TIME SWITCHES, AND ELECTRICAL PRODUCTS.
9. SHOP DRAWINGS SHALL BE SUBMITTED WITHIN THIRTY DAYS AFTER AWARD OF THE CONTRACT. THE CONTRACTOR SHALL SUBMIT EIGHT COPIES OF A COMPLETE LIST OF MATERIALS AND EQUIPMENT INCLUDING MANUFACTURER AND MODEL NUMBER PROPOSED FOR THE JOB. SHOP DRAWINGS SHALL INCLUDE JOB DESCRIPTION, ARCHITECT AND ENGINEER IDENTIFICATION, AND ALL DATA WITH CAPACITIES, SIZES, DIMENSIONS, CATALOG NUMBERS, MANUFACTURER'S BROCHURES, AND SUPPORT DATA.
10. THE CONTRACTOR SHALL HAVE THE OPTION OF ROUTING RACEWAYS UNLESS OTHERWISE NOTED AND SHALL BE COORDINATED WITH OTHER TRADES.
11. CONTRACTOR SHALL PROVIDE ALL J-BOXES, PULL BOXES, ELLS, OFFSETS ETC., FOR A COMPLETE, CODE APPROVED, INSTALLATION OF ALL CONDUIT. FOOTAGE SHOWN ON ELECTRICAL SINGLE LINES AND RISER DIAGRAMS ARE FOR CALCULATION PURPOSES ONLY, AND ARE NOT FOR BIDDING PURPOSES OR MATERIAL TAKEOFF. IT SHALL BE THE RESPONSIBILITY OF THE CONTRACTOR TO REVIEW AND TO COORDINATE WITH MECHANICAL, FIRE PROTECTION, AND PLUMBING DRAWINGS FOR DUCTS, LINES, AND EQUIPMENT.
12. THE CONTRACTOR SHALL PERFORM HIS WORK IN ACCORDANCE WITH ALL GOVERNING STATE, COUNTY, LOCAL CODES, O.S.H.A., THE PRESENTLY ADOPTED NATIONAL ELECTRICAL CODE, AND PRESENTLY ADOPTED CALIFORNIA ELECTRICAL CODE (C.E.C.).
13. THE CONTRACTOR SHALL COORDINATE WITH OTHER TRADES AS TO THE EXACT LOCATION OF THEIR RESPECTIVE EQUIPMENT. SUPPLY POWER AND MAKE CONNECTIONS TO MOTORS AND EQUIPMENT REQUIRING ELECTRICAL CONNECTIONS AS INDICATED ON THE SINGLE LINE DIAGRAM, ELECTRICAL DRAWINGS, AND DRAWINGS OF OTHER TRADES. REVIEW THE DRAWINGS OF OTHER TRADES FOR CONTROL DIAGRAMS, SIZE AND LOCATION OF EQUIPMENT, OBTAINING MANUFACTURER'S SHOP DRAWINGS PRIOR TO ROUGH-IN IN ALL CONDUIT TO THIS EQUIPMENT.
14. CONTRACTOR SHALL USE MATERIALS THAT ARE NEW, AND OF THE SAME MANUFACTURER FOR FOR EACH CLASS OR GROUP OF EQUIPMENT. MATERIALS SHALL BE LISTED AND APPROVED BY THE (U/L) UNDERWRITER'S LABORATORIES FOR THE USE AND ENVIRONMENT, AND SHALL BEAR THE INSPECTION LABEL WHERE SUBJECT TO APPROVAL. MATERIALS SHALL MEET WITH THE APPROVAL OF THE DIVISION OF INDUSTRIAL SAFETY, AND ALL GOVERNING BODIES HAVING JURISDICTION. MATERIALS SHALL BE MANUFACTURED IN ACCORDANCE WITH APPLICABLE STANDARDS ESTABLISHED BY A.N.S.I., U.L., N.E.M.A., AND N.B.F.U. INSTALL PER MANUFACTURER'S RECOMMENDATIONS.
15. THE CONTRACTOR SHALL EXCAVATE ALL TRENCH DEPTHS AND WIDTHS PER THE C.E.C. AND SHALL COMPACT ALL EXCAVATIONS IN A CONTINUOUS LAYER OF NOT MORE THAN 6" COMPACTED DEPTH TO THE REQUIRED DENSITY OF NINETY PERCENT (90%). THE CONTRACTOR SHALL ATTAIN THE SPECIFIED COMPACTION DENSITY BY MAINTAINING THE OPTIMUM MOISTURE CONTENT OF THE FILL MATERIAL.
16. ATTENTION IS CALLED TO THE FACT THAT THERE ARE EXISTING UNDERGROUND UTILITY LINES, THEREFORE, THE CONTRACTOR SHALL USE EXTREME CAUTION WHEN TRENCHING FOR HIS WORK. THE CONTRACTOR SHALL BE RESPONSIBLE FOR THE PROPER AND APPROVED REPAIR OF ANY AND ALL DAMAGES CAUSED BY HIM OR HIS WORK. THE CONTRACTOR SHALL BE RESPONSIBLE FOR ALL SAW CUTTING, TRENCHING, BACKFILLING, COMPACTION, AND PATCHING OF CONCRETE AND ASPHALT AS REQUIRED TO PERFORM HIS WORK.
17. P.V.C. CONDUIT SHALL BE USED UNDERGROUND ONLY, IF APPROVED BY LOCAL CODE. INSTALL PER ALL REQUIRED LOCAL CODES. PROVIDE YELLOW HIGH VOLTAGE METALLIC TAPE + 10" ABOVE ALL UNDERGROUND CONDUITS. ALL CONDUIT SWEEPS, RISERS, AND STUBS ABOVE GRADE SHALL BE I.M.C. WITH FACTORY INSTALLED PVC COATING. SITE INSTALLED 10 MIL HALF LAPPED TAPE IS PROHIBITED.

ENGINEER'S NOTICE TO CONTRACTORS

THE EXISTENCE AND LOCATION OF ANY UNDERGROUND UTILITY PIPES OR STRUCTURES SHOWN ON THESE PLANS WERE OBTAINED BY A SEARCH OF AVAILABLE RECORDS. THESE LOCATIONS ARE APPROXIMATE AND SHALL BE CONFIRMED IN FIELD BY THE CONTRACTOR, SO THAT ANY NECESSARY ADJUSTMENTS CAN BE MADE IN ALIGNMENT AND/OR GRADE OF THE PROPOSED IMPROVEMENT. THE CONTRACTOR IS REQUIRED TO TAKE DUE PRECAUTIONARY MEASURE TO PROTECT ANY UTILITY LINES SHOWN AND ANY OTHER LINES NOT OF RECORD OR NOT SHOWN ON THESE PLANS.

DECLARATION OF DESIGN

THE DESIGN OF THE ELECTRICAL POWER SYSTEM AS SHOWN ON THESE PLANS COMPLIES WITH PROFESSIONAL ENGINEERING STANDARDS AND PRACTICES INCLUDING OBSERVANCE OF MINIMUM VERTICAL AND HORIZONTAL DISTANCES, IN ACCORDANCE WITH APPLICABLE REGULATIONS, FROM EXISTING FACILITIES INCLUDING BUT NOT LIMITED TO WATER AND SEWER LINES, STORM DRAINS, TELECOMMUNICATIONS AND CABLE TELEVISION SYSTEMS. THE DESIGN INCORPORATES PROPER SEPARATION FROM SUCH FACILITIES TO BE INSTALLED AS PART OF THE DEVELOPMENT.

NAME: ADDRESS: PHONE: DATE:

GENERAL NOTES (CONTINUED)

- 18. ALL CONDUIT SHALL BE INSTALLED CONCEALED WHERE PHYSICALLY POSSIBLE.
19. ALL CONDUIT ONLY (C.O.) SHALL HAVE A 3/1 6" PULL WIRE OR ROPE, MINIMUM.
20. ALL CONDUCTORS OF EVERY SYSTEM SHALL BE PERMANENTLY TAGGED IN COMPLIANCE WITH O.S.H.A.
21. THE COMPLETE ELECTRICAL SYSTEM SHALL BE GROUNDED IN ACCORDANCE WITH THE PRESENTLY ADOPTED EDITION OF THE C.E.C., ARTICLE #250.
22. CONDUCTORS SHALL BE CODE GRADE, 600 VOLT CLASS, COPPER, MARKED 24" ALONG ITS LENGTH SHOWING MANUFACTURER'S NAME, MAXIMUM ALLOWABLE VOLTAGE AND SIZE. CONDUCTORS SHALL BE TYPE "THWN" (WET) OR "THHN" (DRY), DELIVER CONDUCTORS TO THE JOB SITE IN UNBROKEN PACKAGES.
23. ALL UNDERGROUND PULLBOXES SHALL HAVE ALL CONDUITS COMPLETELY SEALED W /WEATHERPROOF EXPANSION FOAM AT COMPLETION OF PROJECT.
24. EXACT LOCATION OF ALL ELECTRICAL DEVICES AND EQUIPMENT SHALL BE COORDINATED WITH THE LANDSCAPE DETAILS, OR SECTIONS PRIOR TO INSTALLATION. ALL ELECTRICAL DEVICES AND EQUIPMENT SHALL BE RECESSED IN WALLS UNLESS OTHERWISE NOTED.
25. WHERE A CONFLICT OCCURS BETWEEN THESE NOTES, THE DRAWING OR ELECTRICAL SPECIFICATION ISSUED AS A PART OF THESE DOCUMENTS, THE MORE STRINGENT REQUIREMENT SHALL PREVAIL.
26. AT THE COMPLETION OF THE PROJECT, PROVIDE THE OWNER WITH ONE (1) SET OF COMPLETE, UP TO DATE, "AS-BUILT" REPRODUCIBLE DRAWINGS, SHOWING ACTUAL DEPTHS OF UNDERGROUND CONDUIT RUNS AT ALL LOCATIONS, ALL BROCHURES, OPERATING MANUALS, CATALOGS, SHOP DRAWINGS, ETC. SHALL BE TURNED OVER TO THE OWNER AT PROJECT COMPLETION.
27. AFTER DATE OF ACCEPTANCE BY OWNER, THE COMPLETED PROJECT SHALL BE GUARANTEED FOR A PERIOD OF ONE (1) YEAR. ANY WORK, MATERIAL OR EQUIPMENT FOUND TO BE FAULTY DURING THAT PERIOD SHALL BE CORRECTED IN A TIMELY MANNER, UPON WRITTEN NOTIFICATION, AT THE EXPENSE OF THE ELECTRICAL CONTRACTOR.
28. ENGRAVED PLASTIC NAMEPLATES SHALL BE PROVIDED FOR ALL METER PEDESTAL PLATES SHALL BE 3 PLY, BLACK FACE, WHITE CORE, WITH 1/2" HIGH GOTHIC LETTERING.
29. METERED PEDESTAL SHALL BE PROVIDED WITH RATINGS, COMPONENTS, AND FEATURES IN STRICT ACCORDANCE WITH THE SERVING UTILITIES AND CODE ENFORCING AGENCY, ELECTRICAL DRAWINGS AND SPECIFICATIONS. THE METERED PEDESTAL DISTRIBUTION PANELS CONSIST OF A COMPLETELY ENCLOSED SELF-SUPPORTING, FLOOR STANDING STRUCTURE, OF THE REQUIRED NUMBER OF FORMED VERTICAL PANEL SECTIONS. PROVIDE BOLTED FRAMES AND INSULATING BLOCK TO SUPPORT THE MAIN HORIZONTAL BUS FOR SHORT CIRCUIT STRESS AS INDICATED ON THE DRAWINGS. ALL BUSSING SHALL BE 100% RATED MADE WITH COPPER HAVING A CURRENT DENSITY OF 1,000 AMPS PER SQUARE INCH, METERING PEDESTAL VENTILATED ENCLOSURE WITH NEMA 3R EXTERIOR ENCLOSURE SHALL BE 12-GUAGE STAINLESS STEEL WITH VANDALPROOF LOCKING PAD LOCK COVER
30. ALL EXTERIOR ELECTRICAL DEVICES SHALL BE 12-GUAGE STAINLESS STEEL WITH VANDAL PROOF LOCKING COVER AND TAMPERPROOF SCREWS.
31. ALL UNDERGROUND CONDUIT SHALL BE ENCASED PER DETAIL /15 WITH 1-2 SACK OF RED COLORING IN CONCRETE.

DEPARTMENT OF WATER RESOURCES GENERAL NOTES

- 1. A SEVEN (7) DAY ADVANCE NOTIFICATION IS REQUIRED PRIOR TO STARTING WORK WITHIN STATE WATER PROJECT RIGHT OF WAY. CONTACT THE DEPARTMENT OF WATER RESOURCES, ENGINEERING, ENCROACHMENT PERMIT SECTION, SACRAMENTO, CALIFORNIA AT (800) 800-4397. DWR SOUTHERN FIELD DIVISION SHALL BE SIMULTANEOUSLY NOTIFIED AT (861) 944-8500 EXCEPT AS OTHERWISE PROVIDED HEREIN. MEASURES SHALL BE TAKEN BY THE CONTRACTOR TO PROJECT IN PLACE ANY AND ALL SWP FACILITIES AND APPURTENANCES, INCLUDING BUT NOT LIMITED TO COMMUNICATION AND CONTROL CABLES AND CATHODIC DAMAGE TO SWP FACILITIES AND APPURTENANCES AS A RESULT OF THE CONSTRUCTION, AND FOR ANY OTHER DAMAGE OR LOSSES SUFFERED BY DWR OR ITS WATER CONTRACTORS, INCLUDING POWER, IRRIGATION, MUNICIPAL AND INDUSTRIAL WATER SUPPLY, AND COMMUNICATION LOSSES.
2. BACK FILL WITHIN DWR'S RIGHT-OF-WAY SHALL BE COMPACTED TO 95 PERCENT BASED ON ASTM D 1557 AND SHALL BE INDICATED IN THE NOTE ON EACH APPLICABLE PLAN SHEET.
3. UPON THE COMPLETION OF THE WORK APPROVED UNDER THE ENCROACHMENT PERMIT, ALL WASTE MATERIAL, DEBRIS, ETC. SHALL BE REMOVED FROM DWR RIGI-T-OF-WAY. THE SITE SHALL BE LEFT AS CLOSED TO PRIOR CONDITION AS POSSIBLE.
4. THE PROPOSED TRAIL & ROADS WITHIN THE DEPARTMENT RIGHT-OF-WAY EASEMENT & FEE LAND SHALL BE DESIGNED FOR HS-20 LOADS.
5. DETECTABLE WARNING TAPE IS REQUIRED OVER ALL TRENCHED UTILITIES AND SHALL BE A MIN. OF 18" ABOVE THE UTILITY SITUATED WITHIN DWR'S RIGHT-OF-WAY. SUBSEQUENT REPAIR OR MAINTENANCE OF THE UTILITY SHALL REQUIRE REPLACEMENT OF THE DETECTABLE WARNING TAPE. WARNING TAPE SHALL CONFORM TO THE FOLLOWING: FOR ELECTRICAL CONDUIT(S) THE WARNING TAPE SHALL BE A 3-INCH-WIDE RED DETECTABLE TAPE IMPRINTED WITH "CAUTION BURIED ELECTRICAL CONDUIT".
6. ALL EXCAVATION AND COMPACTION WITHIN THREE 3 FEET OF THE PIPELINE SHALL BE DONE USING HAND HELD TOOLS ONLY. (REGULATIONS ARTICLE 6, SECTION 612.6-4 (B) UTILITY ENCROACHMENTS.)

VICINITY MAP

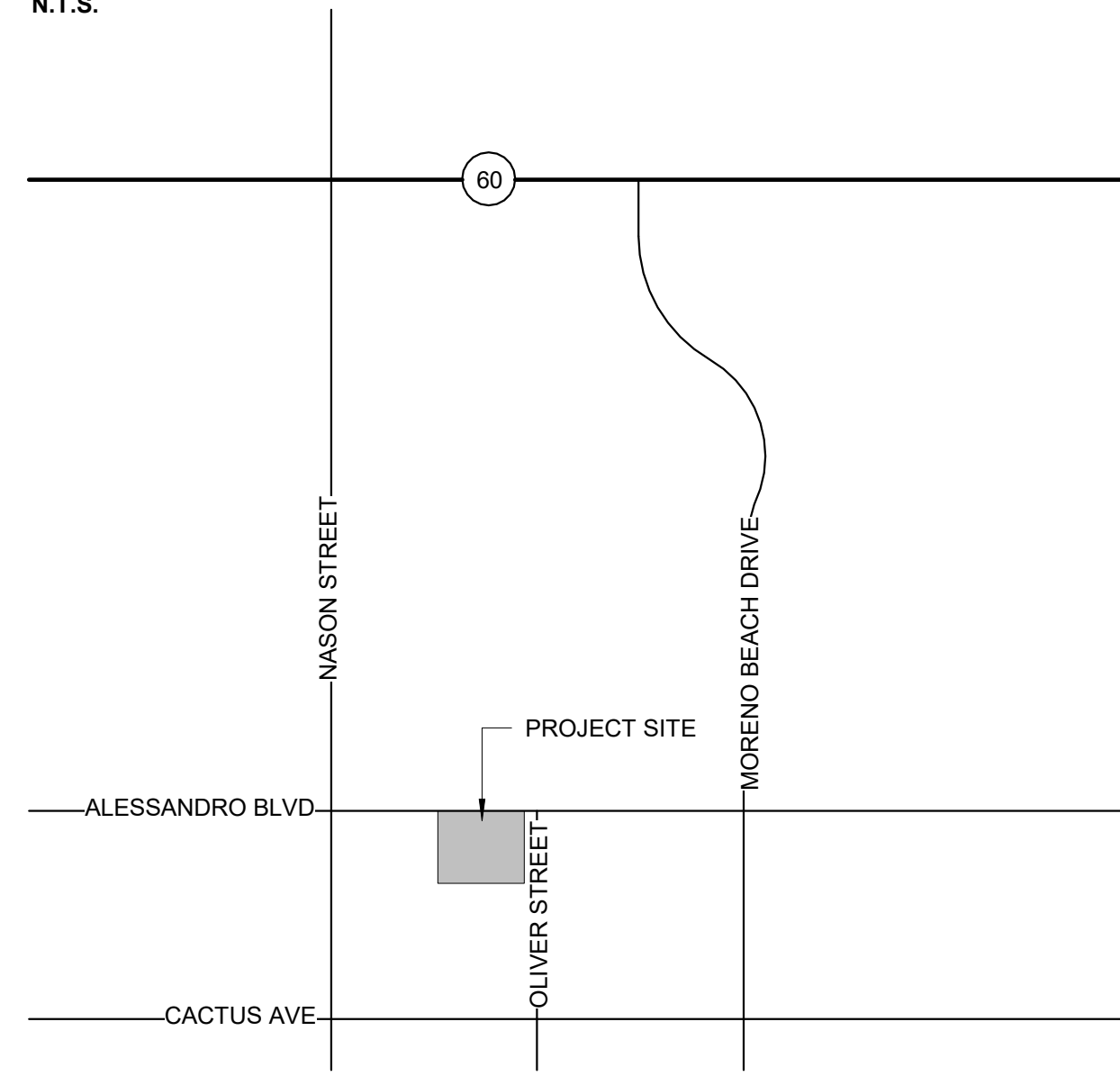

PARK SITE PLAN - SHEET 2.0

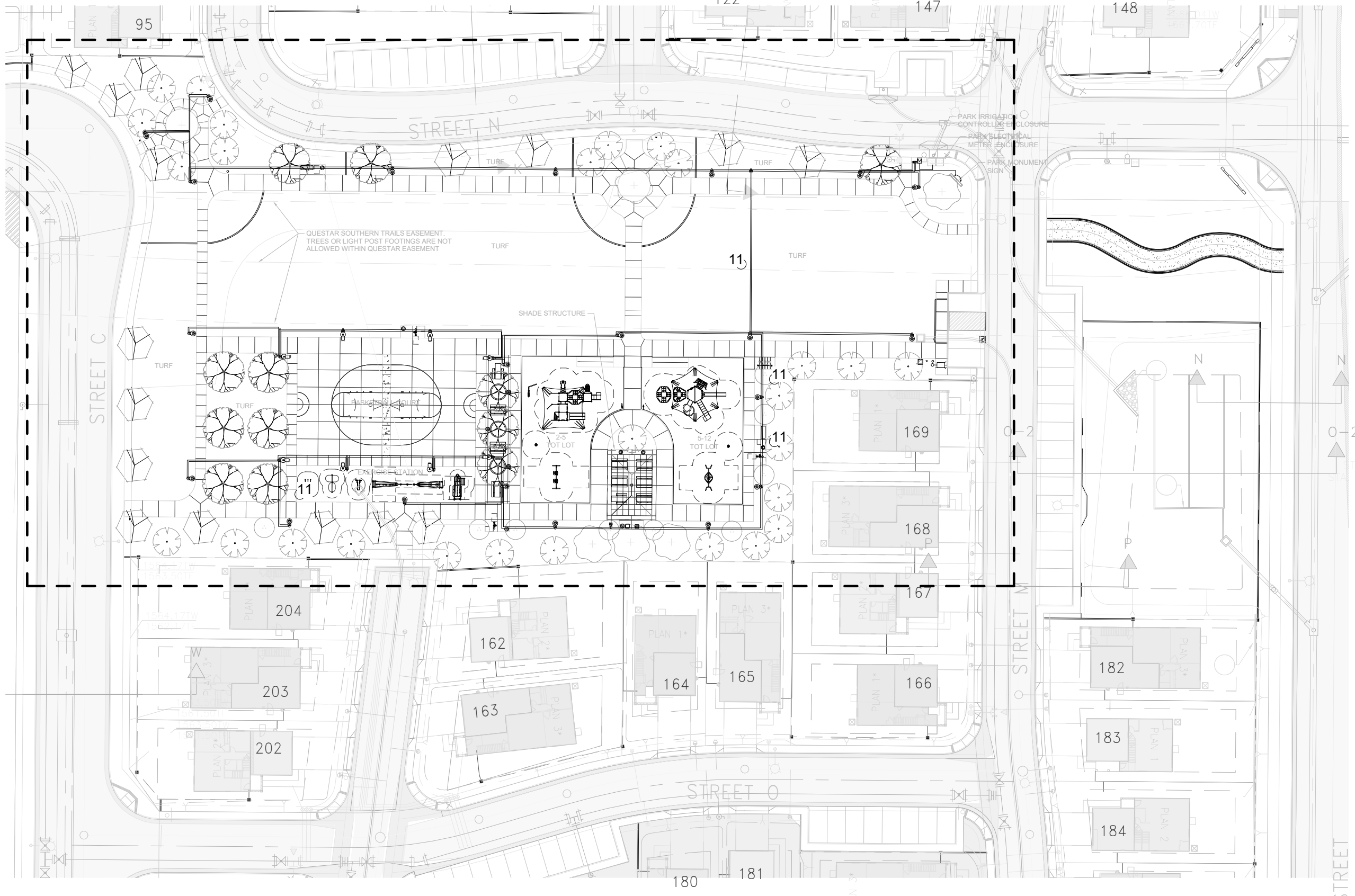

VOLTAGE DROP

Table with 6 columns: METER, CIRCUIT, DISTANCE, AMPS AT 240V, NUMBER OF FIXTURES, VOLTAGE DROP. Rows show calculations for MS-1 circuits with distances of 513', 388', and 567'.

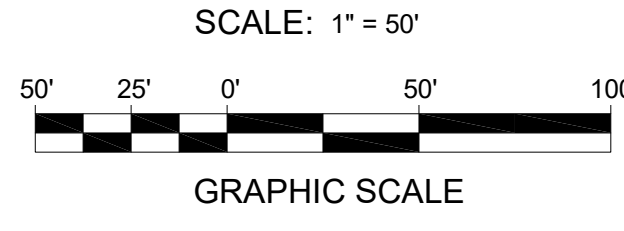

Table with 2 columns: BASIS OF BEARINGS, BENCH MARK. Contains survey data and coordinates.

CITY OF MORENO VALLEY APPROVALS section with approval stamps for City Traffic Engineer and Senior Engineer.

INTELLIGENT LIGHTING SYSTEMS section with project manager and engineer information.

STREET LIGHTING section with project details: TRACT 38236 PARK, SITE LIGHTING PLAN, STREET M, E-1.0, SHEET E-1.0 OF 3.

Attachment: Tract 38236 Park Imp Plans (6417) - THE PUBLIC FACILITIES FEE CREDIT AGREEMENT WITH D.R. HORTON LOS ANGELES HOLDING COMPANY, INC.

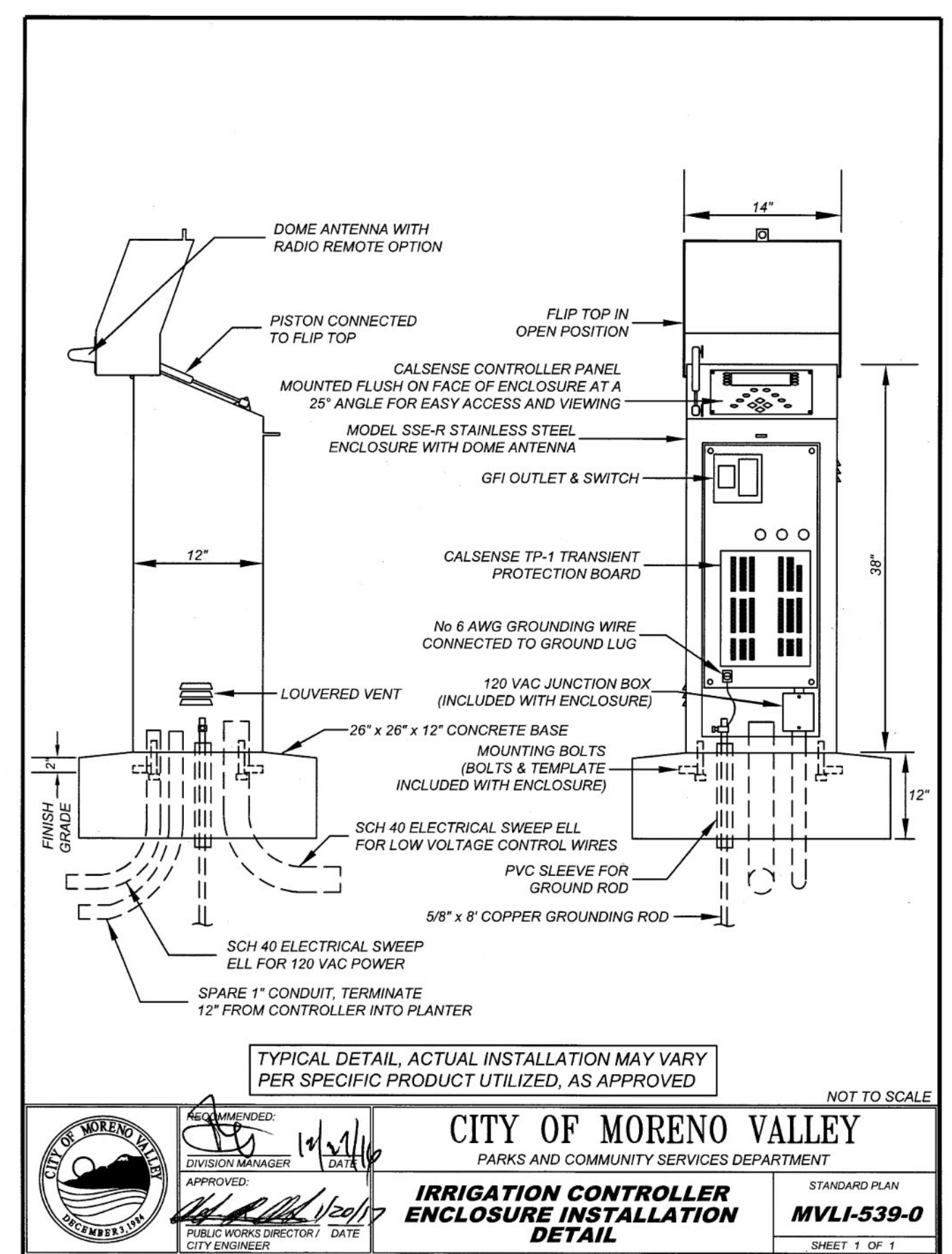
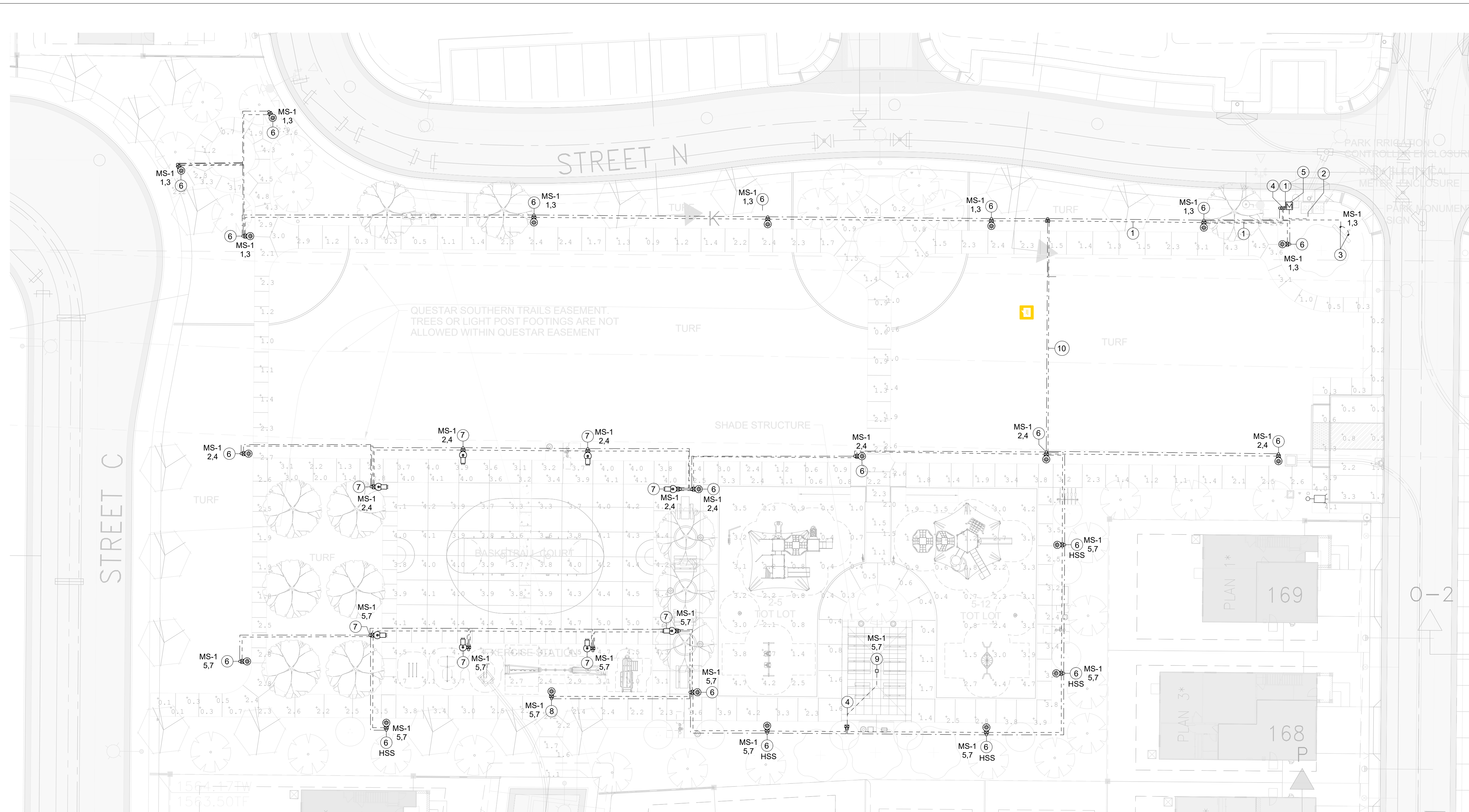

CITY OF MORENO VALLEY
 PARKS AND COMMUNITY SERVICES DEPARTMENT
 STANDARD PLAN
MVLI-539-0
 SHEET 1 OF 1

APPROVED: [Signature]
 DIVISION MANAGER
 DATE: 1/14/16

APPROVED: [Signature]
 CITY ENGINEER
 DATE: 1/14/16

LEGEND	QTY
WALKWAY LIGHTS- 59 WATT, LED TYPE 3 (SEE FIXTURE SCHEDULE SHEET E-3.0) N.T.S.	22 EA
WALKWAY LIGHTS- 59 WATT, LED TYPE 5 (SEE FIXTURE SCHEDULE SHEET E-3.0) N.T.S.	1 EA
AREA LIGHTS- 56 WATT, LED TYPE 3 (SEE FIXTURE SCHEDULE SHEET E-3.0) N.T.S.	8 EA
MONUMENT UP LIGHTS- 13WATT, LED (SEE FIXTURE SCHEDULE AND MANUFACTURER'S DETAIL FOR DIRECT BURIAL INSTALLATION) N.T.S.	2 EA
ELECTRICAL METER PEDESTAL (SEE DETAIL SHEET E-3.0) N.T.S.	1 EA
#3-1/2 PULL BOX, STD. #MVGF-618A-0 (SEE DETAIL SHEET E-3.0) AND LOW VOLTAGE CONCRETE UNDERGROUND PULLBOX 9" ROUND	32 EA
CONDUIT RUN CONCEALED BELOW GRADE, 1-1/2" SCH. 40 PVC CONDUIT AND CONDUCTORS 2#8 & 1#8 GROUND	
CONDUIT RUN CONCEALED BELOW GRADE, 1" SCH. 40 PVC CONDUIT WITH PULL ROPE FOR FUTURE CAMERA SYSTEM	
CANOPY LIGHT- 54 WATT, LED TYPE 5 (SEE FIXTURE SCHEDULE SHEET E-3.0) N.T.S.	1 EA

- CONSTRUCTION NOTES**
- 2" SCH. 40 PVC CONDUIT W/ 6 #6 & 1 #8 E/G.
 - SCH. 40 PVC CONDUIT W/ 2#8 & 1#8 GROUND PER CITY OF MORENO VALLEY STANDARD MVLI-539-0. CONTRACTOR TO COORDINATE WITH LANDSCAPE CONTRACTOR.
 - INSTALL 13W LED UP LIGHT - SEE LUMINAIRE SCHEDULE-3.0
 - INSTALL 3/4" SCH 40 PVC CONDUIT W/ 2#10 & 1#10 E/G TO CANOPY HANDHOLE. CONTRACTOR TO COORDINATE HANDHOLE AT BASE OF STRUCTURE. CONTRACTOR TO COORDINATE ROUTING OF CONDUCTORS THROUGH SHADE STRUCTURE.
 - INSTALL METER PEDESTAL - SEE DETAIL SHEET E-3.0
 - INSTALL 59W LED TYPE 3 WALKWAY LIGHT - SEE LUMINAIRE SCHEDULE E-3.0
 - INSTALL 56W LED POLE LIGHT - SEE LUMINAIRE SCHEDULE E-3.0
 - INSTALL 59W LED TYPE 5 WALKWAY LIGHT - SEE LUMINAIRE SCHEDULE E-3.0
 - INSTALL 54W VANDAL RESISTANT CANOPY LIGHT - SEE LUMINAIRE SCHEDULE E-3.0
 - 1-1/2" SCH. 40 PVC CONDUIT W/ 4 #6 & 1 #8 E/G.

PHOTOMETRIC RESULTS

PHOTOMETRIC RESULTS OBTAINED USING A LLF OF 0.8.

CALCULATION SURFACE	AVERAGE	MIN	MAX
COURT / EXERCISE EQUIPMENT	4.12 FC	2.9 FC	5.3 FC
WALKWAY	2.34 FC	0.2 FC	4.8 FC
TOT LOT WEST	1.94 FC	0.4 FC	4.7 FC
TOT LOT EAST	2.26 FC	0.4 FC	4.7 FC

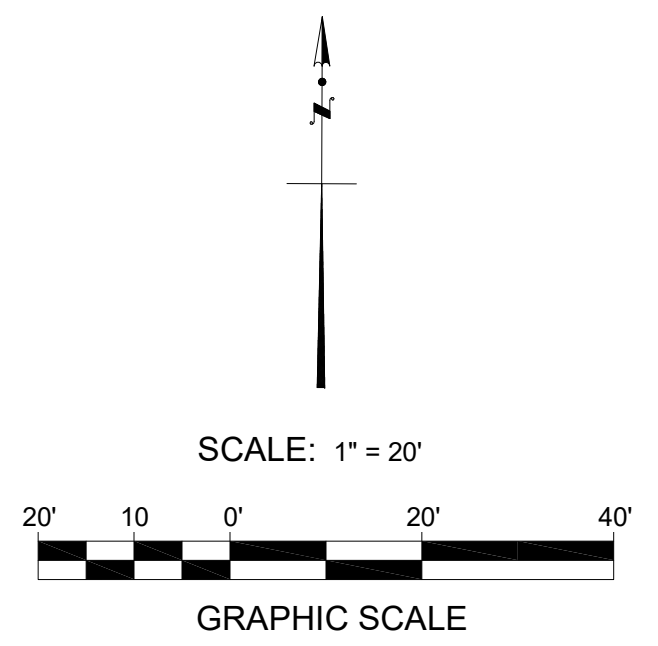

DIGALERT
 CALL 811 or 1-800-422-4133
 2 Working Days Before You Dig
 WWW.CALL811.COM

MARK	REVISIONS	APPR	DATE

DESIGNED BY H.LOVE DRAWN BY H.LOVE CHECKED BY J.LOVE

CITY OF MORENO VALLEY APPROVALS

APPROVED BY	DATE	BY
HENRY Q. NGO, PE CAPITAL PROJECTS DIVISION MANAGER RCE 58590		
MICHAEL D. LLOYD, PE PUBLIC WORKS DIRECTOR/CITY ENGINEER RCE 69663		

INTELLIGENT LIGHTING SYSTEMS

PREPARED UNDER SUPERVISION OF

ANTHONY WINSTON III
RCE: E-20881

ENGINEER OF RECORD'S SEAL

STREET LIGHTING

TRACT 38236 PARK
SITE LIGHTING PLAN
STREET M

ACCT No XXXX-70-XXXX

E-2.0

SHEET E-2.0 OF 3

PROJECT No Project Number

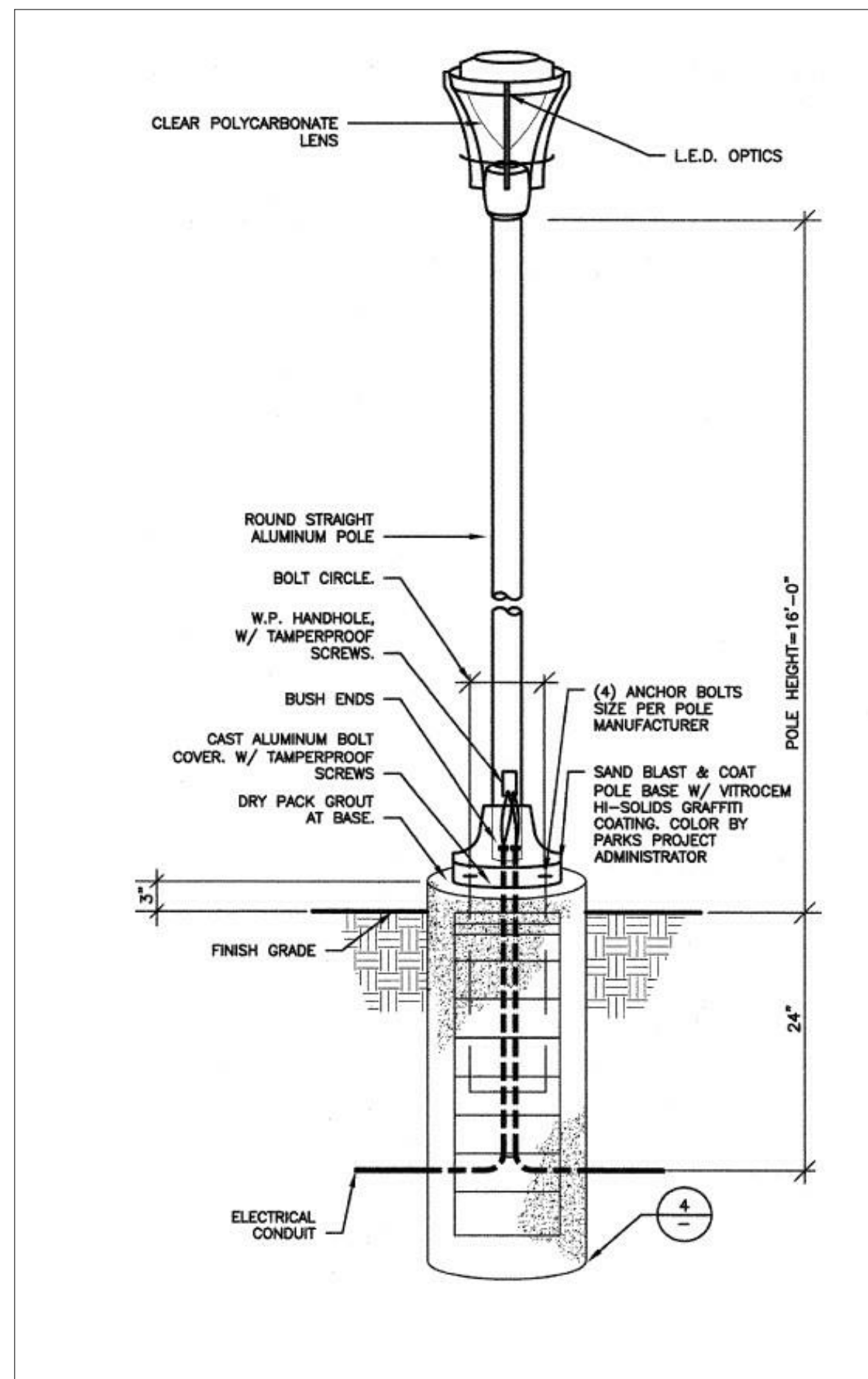

WALKWAY FIXTURE
SCALE: N.T.S.

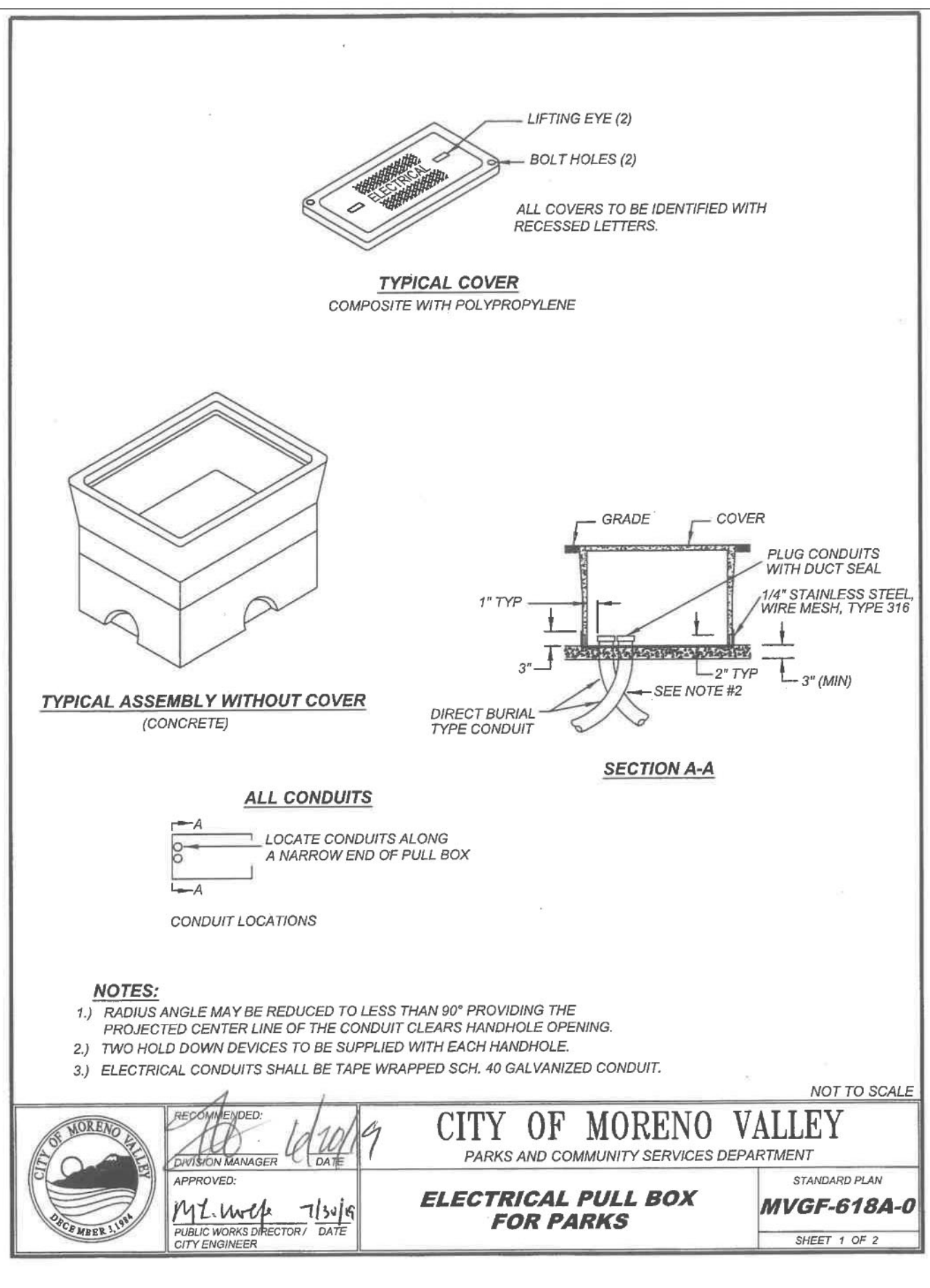

PULLBOX DETAIL
SCALE: N.T.S.

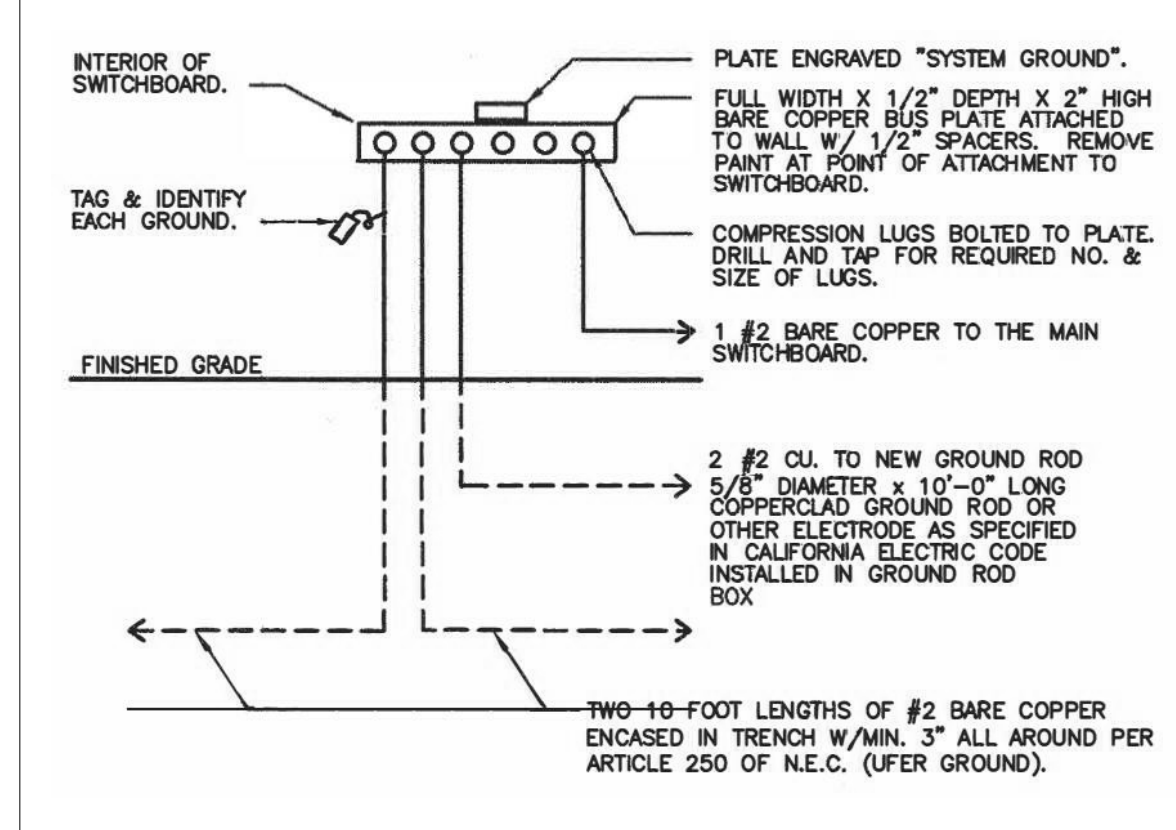

SYSTEM GROUND DETAIL
SCALE: N.T.S.

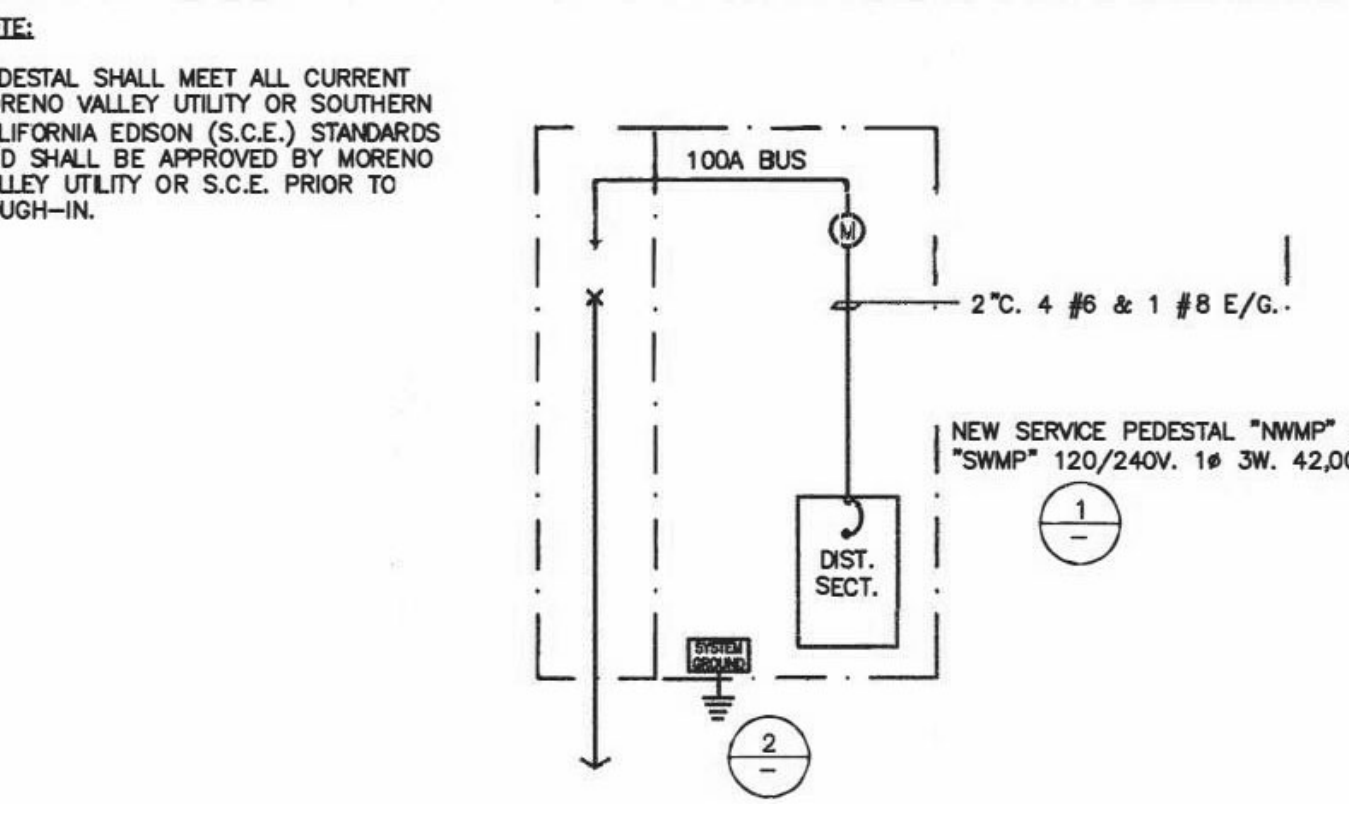

SINGLE LINE - NWMP & SWMP
SCALE: N.T.S.

FIXTURE SCHEDULE

CONTACT INTELLIGENT LIGHTING SYSTEMS FOR FIXTURE QUOTE SALES@LIGHTINGSYSTEMS.COM (424) 666-9071

MANUFACTURER	FIXTURE	POLE	WATTS	TYPE	SHIELDING	POLE HEIGHT	QTY
KIM LIGHTING	SRSA2-1SA-72L-260-4K7-3-CP-UNV-BL-4 TYPE 3 DISTRIBUTION	HSAF16-641880-HBC2	59	LED_40K	AS INDICATED	16'	22
KIM LIGHTING	SRSA2-1SA-72L-260-4K7-5-CP-UNV-BL-4 TYPE 5 DISTRIBUTION	HSAF16-641880-HBC2	59	LED_40K	NONE REQUIRED	16'	1
GARDCO	ECF-S-32L-530-NW-G2-AR2-3-120 TYPE 3 DISTRIBUTION	SQUARE ALUMINUM	56	LED_40K	AS INDICATED	20'	8
KENALL	HERCULUX H1212FM-PP-DB-50L40K-120	N/A	54	LED_40K	NONE REQUIRED	CANOPY MOUNT	1
LITELINES	CFS-35-11-LED24-SV-DB-GS-HFL	N/A	30	LED_40K	NONE REQUIRED	DIRECT BURIAL	2

ALL SUBSTITUTIONS MUST BE APPROVED IN WRITING BY ENGINEER OF RECORD, E.EOR, MINIMUM (10) TEN DAYS PRIOR TO BID. FIXTURE CUT SHEETS, IES FILES, AND FULL PHOTOMETRIC CALCULATIONS REQUIRED FOR EVALUATION OF SUBSTITUTION BY E.EOR.

DIGALERT

CALL 811 or 1-800-422-4133 2 Working Days Before You Dig www.call811.com

BASIS OF BEARINGS:	BENCH MARK:

WALKWAY BASE DETAIL
SCALE: N.T.S.

WALKWAY BASE DETAIL
SCALE: N.T.S.

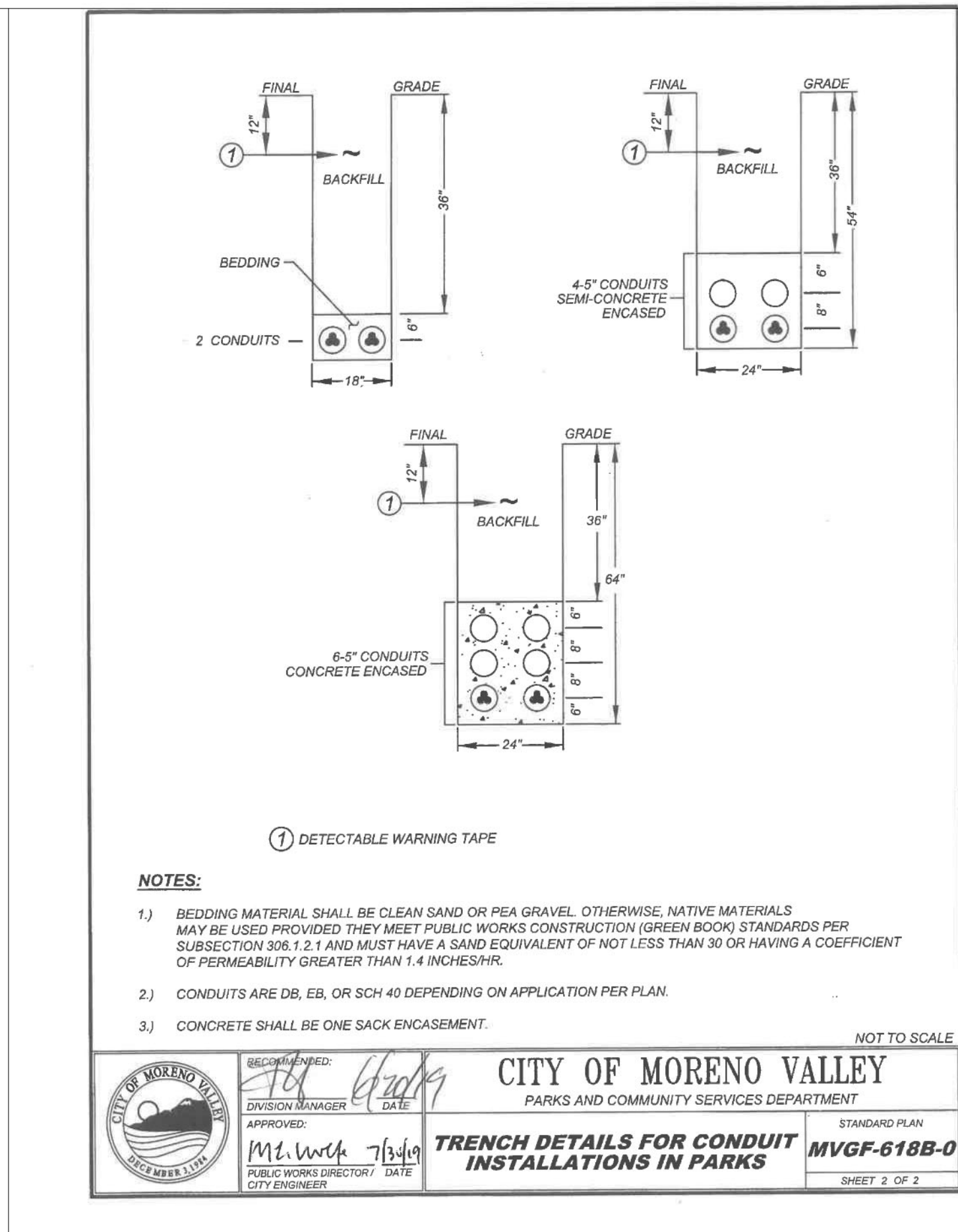

TRENCH DETAIL
SCALE: N.T.S.

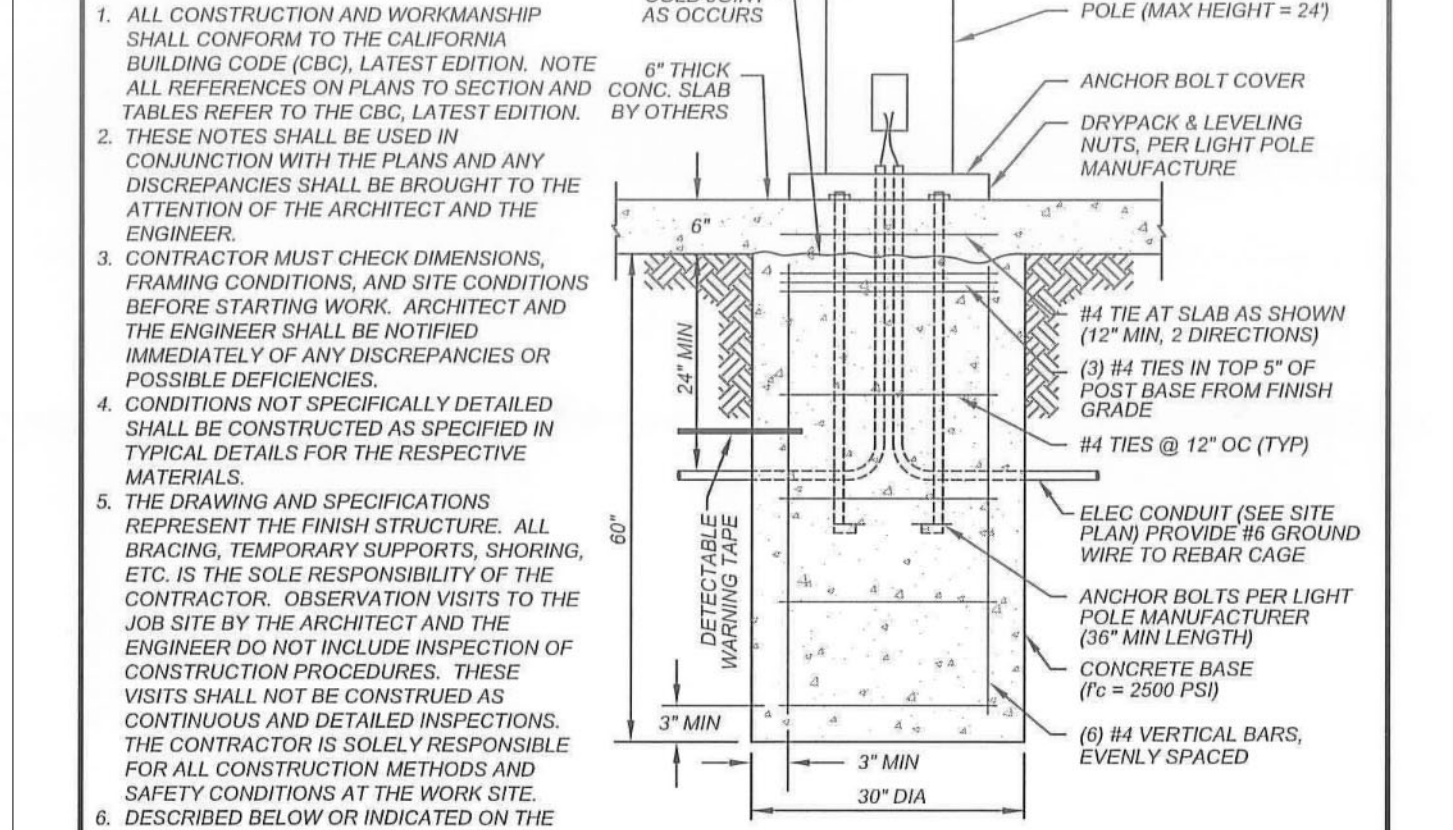

POLE BASE FIXTURE FOOTING FOR PARKS
SCALE: N.T.S.

CITY OF MORENO VALLEY APPROVALS

RECOMMENDED: HENRY Q. NGO, PE CAPITAL PROJECTS DIVISION MANAGER RCE 88590

APPROVED: MICHAEL D. LLOYD, PE PUBLIC WORKS DIRECTOR/CITY ENGINEER RCE 66663

WALKWAY BASE DETAIL
SCALE: N.T.S.

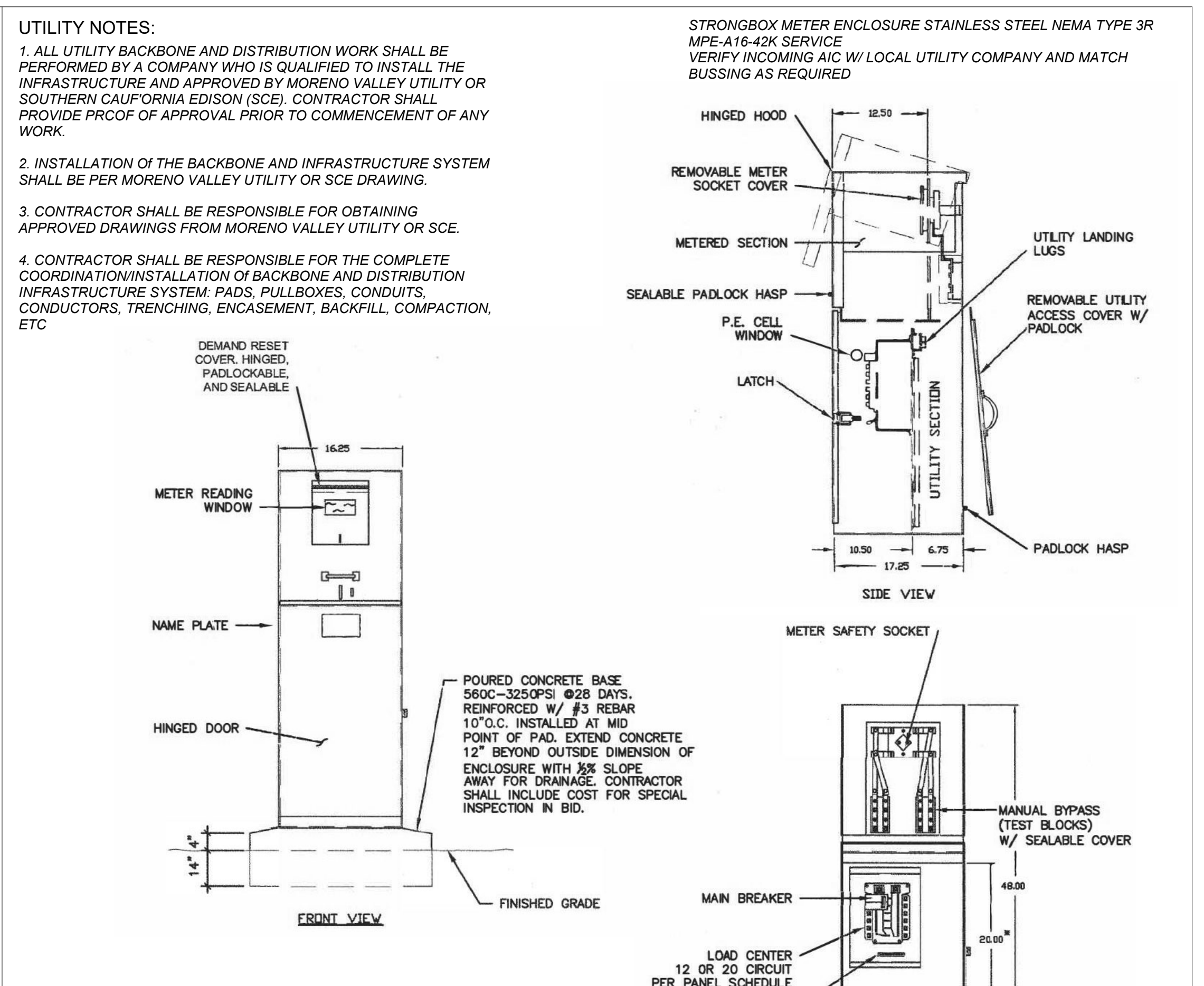

SERVICE PEDESTAL ELEVATION
SCALE: N.T.S.

PANEL SCHEDULE: MS-1 (PARK)

Circuit	Circuit Description	Trip	Poles	A	B	Poles	Trip	Circuit Description	Circuit
1	STREET LIGHTING (8) 59W, (2) 30W	20A	2	266	287.5	2	20A	STREET LIGHTING (5) 56W, (5) 59W	2
3	STREET LIGHTING (1) 54W, (4) 56W, (8) 59W	20A	2	375	300	1	20A	TIME SWITCH	6
7	IRRIGATION CONTROLLER	20A	2	90				SPARE	8
9	SPARE							SPARE	10
11	SPARE							SPARE	12
13	SPARE							SPARE	14
15	SPARE							SPARE	16
17	SPARE							SPARE	18
19	SPARE							SPARE	20
21	SPARE							SPARE	22
23	SPARE							SPARE	24
Total Load				1318.5	1018.5				
Amps (Phase)				10.99	8.49				

PANEL SCHEDULE
SCALE: N.T.S.

Load Classification	Connected Load (VA)	Demand Factor	Est. Demand	Panel Totals
Street Lighting	2337	125%	2921.25	Total Connected Load: 2337
				Total Est. Demand: 2921.25
				Total Connected Amps: 9.74
				Total Est. Demand Amps: 12.17

PANEL SCHEDULE
SCALE: N.T.S.

STREET LIGHTING

TRACT 38236 PARK SITE LIGHTING PLAN

STREET M

ACC'T No XXXX-70-77-XXXX

E-3.0

SHEET E-3.0 OF 3

PROJECT No Project Number



Report to City Council

TO: Mayor and City Council

FROM: Kenneth Reichle, Chief of Police

AGENDA DATE: October 17, 2023

TITLE: ROAD CLOSURES FOR FUN COLOR RUN

RECOMMENDED ACTION

Recommendation:

1. Authorize the road closure of the following streets between the hours of 7:45 a.m. and 12:00 p.m. on Saturday, November 18, 2023, to control traffic and promote safety for event staff and runners:
 - a. Eastbound lanes of Alessandro Boulevard between Frederick Street and Graham Street
 - b. Graham Street between Alessandro Boulevard and Brodiaea Avenue
 - c. Brodiaea Avenue between Graham Street and Frederick Street
 - d. Frederick Street between Resource Avenue and Alessandro Boulevard
 - e. Corporate Way
 - f. Resource Way
 - g. Calle San Juan De Los Lagos between Frederick Street and Veterans Way
 - h. Veterans Way between Calle San Juan De Los Lagos and Alessandro Boulevard.

SUMMARY

The City's inaugural Fun Color Run, managed by the Parks & Community Services Department, will occur on Saturday, November 18, 2023, from 9:00 a.m. to 12:00 p.m. To keep participants and staff safe along the two-mile route, the Moreno Valley Police Department will effectuate the closure of necessary streets and street sections and provide deputies to maintain traffic control and security.

DISCUSSION

The inaugural Fun Color Run will begin and conclude in the Civic Center Amphitheater parking lot. The Fun Color Run consists of two flights: "Group 1" will be released at 9:00 a.m., and "Group 2" will be released at 9:30 a.m. Runners, joggers, and walkers will travel a pre-determined two-mile course. As participants navigate the course, they will be afforded the option to be sprayed with different colors of corn starch. At the end of the course, all participants will gather for concluding remarks and prizes. Event organizers anticipate approximately 500 participants.

The Fun Color Run Path of Travel:

Event participants will depart the Civic Center's parking lot and proceed onto Frederick Street. Once on Frederick Street, participants will travel north to Alessandro Boulevard and make a right turn. After turning right onto Alessandro Boulevard, participants will proceed eastbound in the eastbound lanes of Alessandro Boulevard to Graham Street. Upon reaching the intersection of Alessandro Boulevard and Graham Street, participants will turn right and head southbound on Graham Street to Brodiaea Avenue.

When the participants reach Graham Street and Brodiaea Avenue, they will proceed westbound on Brodiaea Avenue to Frederick Street. Participants will travel northbound on Frederick Street from Brodiaea Avenue to Calle San Juan De Los Lagos, turning left and proceeding west. Finally, participants will turn right and proceed northbound on Veterans Avenue to the west entrance of the Civic Center Amphitheater's parking lot to the finish line.

Proposed road closures are as follows:

- a. Eastbound lanes of Alessandro Boulevard between Frederick Street and Graham Street
- b. Graham Street between Alessandro Boulevard and Brodiaea Avenue
- c. Brodiaea Avenue between Graham Street and Frederick Street
- d. Frederick Street between Resource Avenue and Alessandro Boulevard
- e. Corporate Way
- f. Resource Way
- g. Calle San Juan De Los Lagos between Frederick Street and Veterans Way
- h. Veterans Way between Calle San Juan De Los Lagos and Alessandro Boulevard

As part of the Fun Color Run planning process, businesses and residents potentially impacted by the street closures receive written notification of the scheduled street closures. The Moreno Valley Parks & Community Services Department will complete all written notices. Additional advanced public notices will be made via the City's MVTV-3 broadcast system, the City's website, and electronic message boards. The Moreno

Valley Police Department will notify the Moreno Valley Fire Department, American Medical Response, and the Riverside Transit Authority of the road closures, if approved.

ALTERNATIVES

- 1. Approve and authorize the recommended actions as presented in this staff report.
Staff recommends this alternative as it promotes the safety of staff and participants.
- 2. Disapprove and authorize the recommended actions as presented in this staff report.
Staff does not recommend this alternative.

FISCAL IMPACT

The adopted FY 2023/24 Police Department operating budget will absorb the cost for all proposed street closures, traffic control, and security costs.

NOTIFICATION

N/A

PREPARATION OF STAFF REPORT

Prepared By:
Deputy Christopher Loucks
Police Department

Department Head Approval:
Captain Kenneth Reichle
Police Chief

Concurred By:
Melissa Walker
Public Works Director / City Engineer

Concurred By:
Jeremy Bubnick
Parks & Community Services Director

Concurred By:
Shanna Palau
Senior Contract Analyst

CITY COUNCIL GOALS

Public Safety. Provide a safe and secure environment for people and property in the community, control the number and severity of fire and hazardous material incidents, and provide protection for citizens who live, work and visit the City of Moreno Valley.

Positive Environment. Create a positive environment for the development of Moreno Valley's future.

CITY COUNCIL STRATEGIC PRIORITIES

1. Economic Development

- 2. Public Safety
- 3. Library
- 4. Infrastructure
- 5. Beautification, Community Engagement, and Quality of Life
- 6. Youth Programs

ATTACHMENTS

To view large attachments, please click your “bookmarks”  on the left hand side of this document for the necessary attachment.

- 1. Fun Color Run 2023 - Route Overview

APPROVALS

Budget Officer Approval	<u>✓ Approved</u>	10/10/23 8:15 AM
City Attorney Approval	<u>✓ Approved</u>	
City Manager Approval	<u>✓ Approved</u>	10/10/23 8:23 AM

Fun Color Run

11/18/23 ; 8am-12pm ; Civic Center Amphitheater

Route Overview

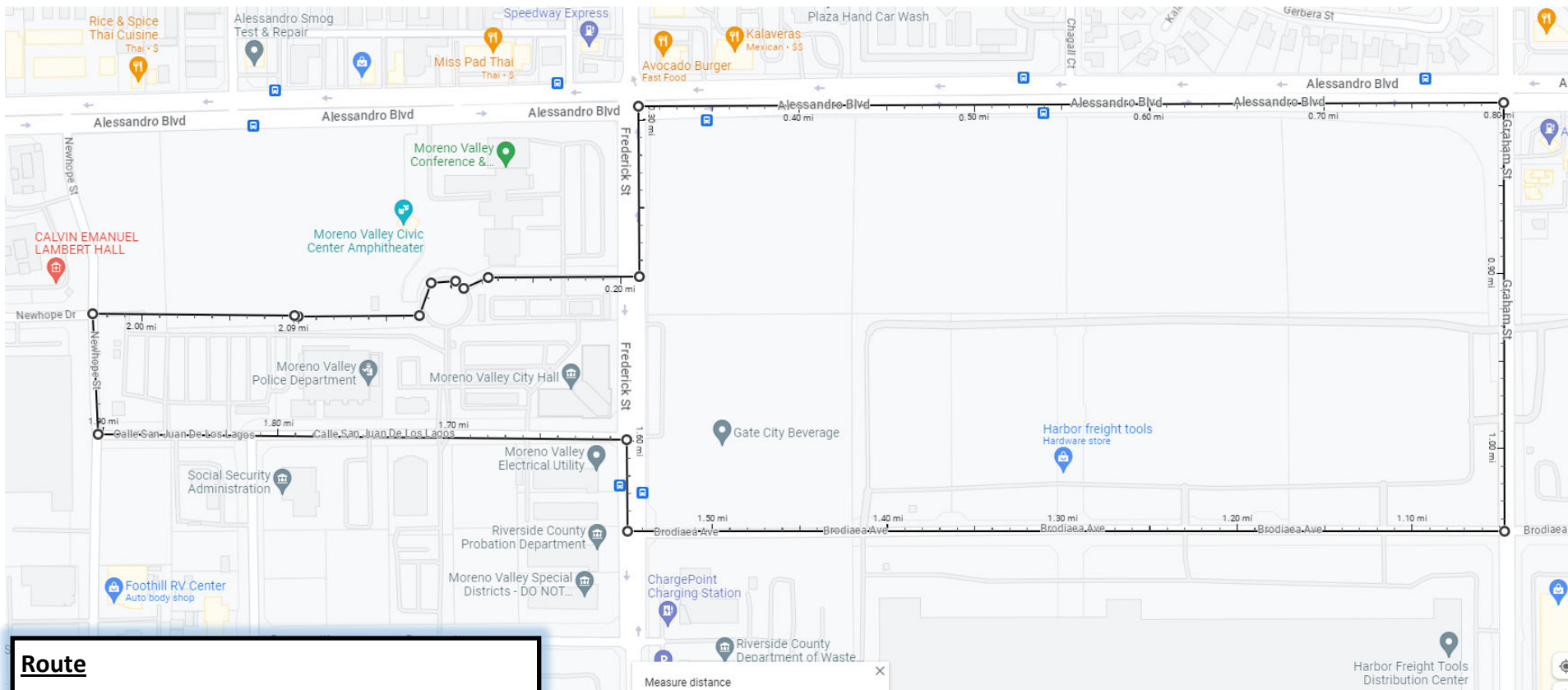

Route

- Distance: 2.09 miles
- Approximate time to complete: 30-45 min walk/run

Attachment: Fun Color Run 2023 - Route Overview (6409 : ROAD CLOSURES FOR FUN COLOR RUN)

Fun Color Run

11/18/23 ; 8am-12pm ; Civic Center Amphitheater
Route Stations: Overview



Route Timeline

- Setup—7:45 AM-9:00 AM
- Route occupied—9:00 AM-11:00 AM
- Route teardown—11:00 AM-12:00 PM

Legend

- Color Station (4)
- Water Station (3)
- First Aid Station (2)
- First Aid Transport (3)
- Restrooms (2)
- Trash Boxes

Attachment: Fun Color Run 2023 - Route Overview (6409 : ROAD CLOSURES FOR FUN COLOR RUN)

Fun Color Run

11/18/23 ; 8am-12pm ; Civic Center Amphitheater
Route Stations: Street Name Overview

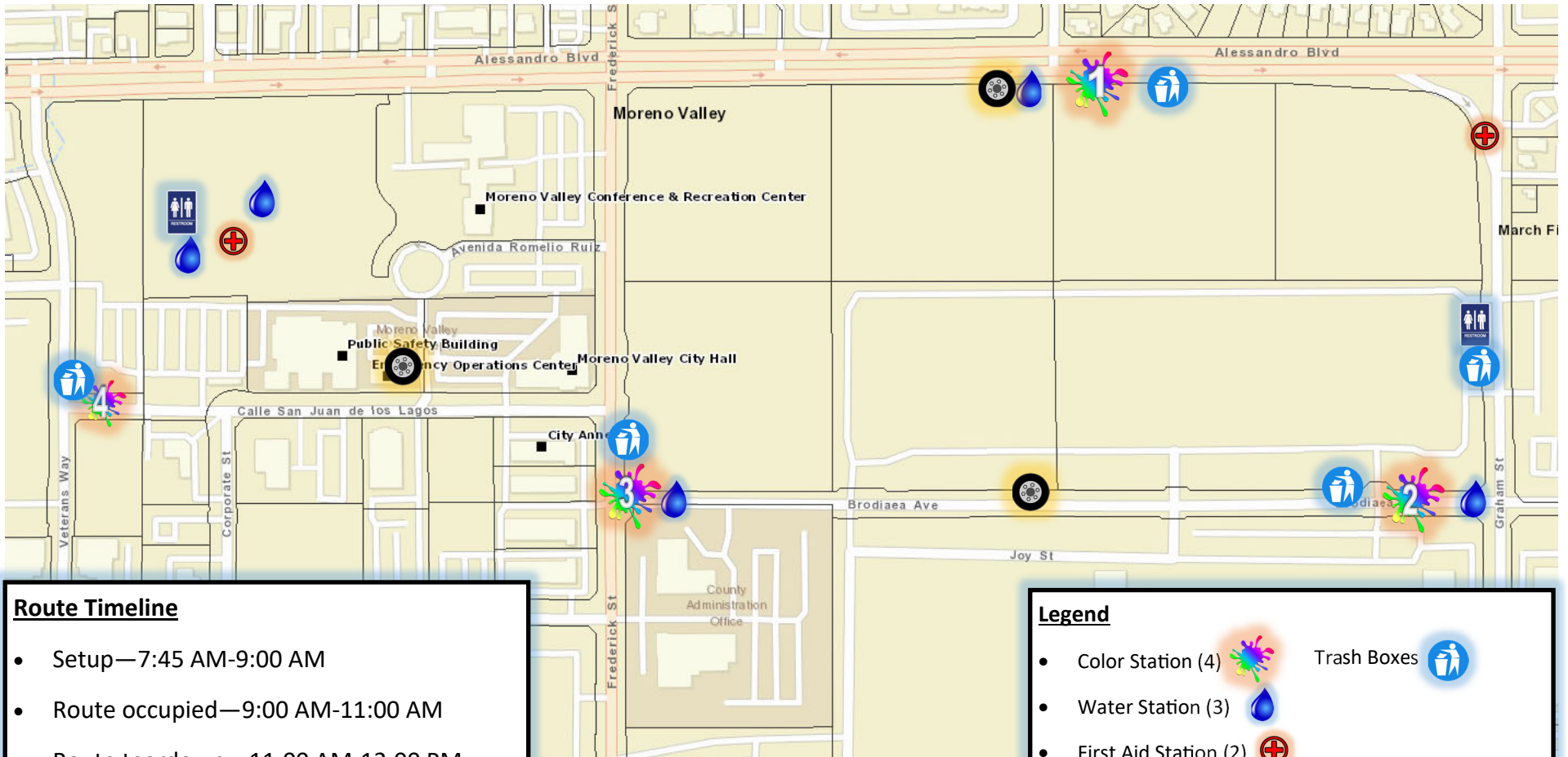

Route Timeline

- Setup—7:45 AM-9:00 AM
- Route occupied—9:00 AM-11:00 AM
- Route teardown—11:00 AM-12:00 PM

Legend

- Color Station (4)
- Water Station (3)
- First Aid Station (2)
- First Aid Transport (3)
- Restrooms (2)
- Trash Boxes



Report to City Council

TO: Mayor and City Council

FROM: Melissa Walker, Public Works Director/City Engineer

AGENDA DATE: October 17, 2023

TITLE: REPORT OF EVALUATING POTENTIAL COMMERCIAL VEHICLE PARKING ON PROLOGIS LANE

RECOMMENDED ACTION

Recommendation:

Receive and file.

SUMMARY

At the City Council Study Session on May 9, 2023, staff was directed to evaluate Prologis Lane, located on the east end of the City as a potential street to serve as additional parking for commercial vehicles. Staff conducted a thorough evaluation including community outreach, analyzing street capacity, and determining truck route accessibility. Based on the findings, staff does not recommend Prologis Lane be designated as a truck parking location at this time.

DISCUSSION

Prologis Lane is located east of the intersection of Eucalyptus Avenue and Auto Mall Drive in the eastern area of the City. Prologis Lane is a 600-foot-long cul-de-sac and is currently signed with No Parking Anytime restrictions throughout the street. The street is 40 feet wide from curb-to-curb and is divided by a double yellow centerline.

There are two buildings that share access along Prologis Lane; Santa Fe Warehouse and MainFreight. Santa Fe Warehouse located on the eastside is a warehousing, fulfillment, global logistics, and supply chain distribution center. Mainfreight, located on the westside is a global supply chain and logistics provider that specializes in transport and warehousing. Both businesses rely heavily on Prologis Lane to serve as the primary entrance to their facilities.

City staff reached out to representatives for both locations to discuss the potential for Prologis Lane to be designated as dedicated truck parking location. Both representatives expressed serious concerns with the proposition and were not in favor of the proposed location. First, as a logistic center they voiced concerns with the impacts the overnight truck parking would have to their daily operations. Both businesses rely heavily on the ability to pick-up and drop-off supplies utilizing Prologis Lane. Currently, Prologis Lane is 40 feet wide, allowing truck parking would reduce the travel lanes significantly and impact day-to-day operations. Secondly, the businesses expressed concerns with the increased trash, theft and damages that occur daily in the area and feel security would be paramount.

City Staff also reviewed the accessibility to Prologis Lane and determined a direct truck route is currently not defined. The nearest truck routes are Moreno Beach Drive from the 60 Freeway to Alessandro Boulevard and Redlands Boulevard from the 60 Freeway to the northern city limits. Access to Prologis Lane would require commercial vehicles to travel on non-designated truck routes.

City staff presented the findings to the Traffic Safety Commission (TSC) on August 2, 2023. Based on the findings, the commission unanimously voted to not recommend Prologis Lane as a commercial parking location at this time.

Staff does not recommend Prologis Lane be designated as a truck parking location at this time.

ALTERNATIVES

This is not an action item.

FISCAL IMPACT

There is no fiscal impact on parking evaluation.

NOTIFICATION

Publication of agenda

PREPARATION OF STAFF REPORT

Prepared By:
Wei Sun, T.E., PTOE
City Traffic Engineer

Department Head Approval:
Melissa Walker, P.E.
Public Works Director/City Engineer

CITY COUNCIL GOALS

None

CITY COUNCIL STRATEGIC PRIORITIES

- 1. Economic Development
- 2. Public Safety
- 3. Library
- 4. Infrastructure
- 5. Beautification, Community Engagement, and Quality of Life
- 6. Youth Programs

ATTACHMENTS

To view large attachments, please click your “bookmarks”



on the left hand side of this document for the necessary attachment.

- 1. Prologis Lane Study
- 2. Attachments from Prologis Lane Study Final

APPROVALS

Budget Officer Approval	<u>✓ Approved</u>	10/09/23 9:13 AM
City Attorney Approval	<u>✓ Approved</u>	
City Manager Approval	<u>✓ Approved</u>	10/09/23 3:17 PM

PROLOGIS LANE TRAFFIC ENGINEERING STUDY

To: Mike Lee, City Manager
 From: Melissa Walker, P.E., Public Works Director/City Engineer
 Date: June 29, 2023
 Subject: Evaluation of Commercial Vehicle Parking on Prologis Lane

LOCATION:

Prologis Lane south of Eucalyptus Avenue

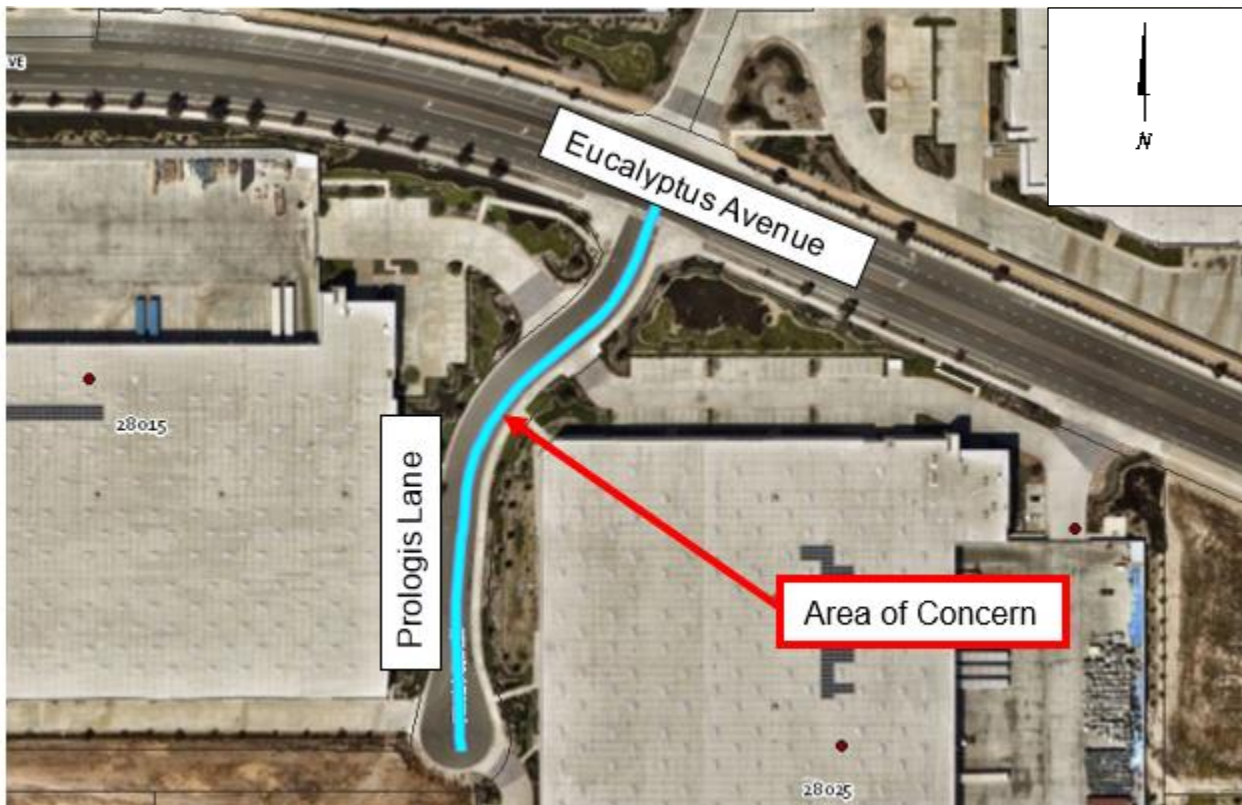

BACKGROUND:

Prologis Lane is located east of the intersection of Eucalyptus Avenue and Auto Mall Drive in the eastern area of the City. Prologis Lane is a 600-foot-long cul-de-sac and is currently signed with No Parking Anytime restrictions throughout the street. The street is 40 feet wide from curb-to-curb and is divided by a double yellow centerline.

Attachment: Prologis Lane Study (6393 : REPORT OF EVALUATING POTENTIAL COMMERCIAL VEHICLE PARKING ON PROLOGIS LANE)

There are two buildings that share access and use Prologis Lane; the building to the east of Prologis Lane is currently occupied by Santa Fe Warehouse, which is a warehousing, fulfillment, global logistics, and supply chain distribution center and the building to the west of Prologis Lane is Mainfreight, a global supply chain and logistics provider that specializes in transport and warehousing.

DISCUSSION:

At the May 9, 2023, City Council Study Session, staff was directed to identify areas in the east end of the City for designated commercial vehicle parking. Prologis Lane was identified as a potential street that can be an additional parking facility for commercial vehicle drivers.

Community Outreach

Staff spoke to Mia Crespo, Vice President of Operations for Santa Fe Warehouse (951) 416-0595, and Angie Smith, Real Estate & Customer Experience Manager of Prologis (909) 673-8728 to inform them of the City's proposal to designate this street as a commercial vehicle parking area. Both representatives expressed strong opposition and were not in favor of this designation. They cited significant issues to their operations and increases in trash and damages they will sustain in the area that would mostly be absorbed by them. In addition, this action may exacerbate the ongoing theft and transient issue that they are currently experiencing. Please see the email (attached) from Ms. Smith stating their opposition.

Staff also spoke to the Operations Manager of Mainfreight Mr. Henry Martinez (562) 233-4095 and received an email response from Ms. Amelia Williamson, Branch Manager (951) 419-6290 regarding the commercial vehicle parking designation. Similar to Santa Fe and Prologis, both Mainfreight managers expressed opposition to this proposal and had safety and security concerns. Please see the email (attached) from Ms. Williamson stating her opposition.

Experiences at other locations

P&G and Floor and Décor

The facilities of P&G and Floor and Décor off Cosmos Street and Krameria Avenue were once heavily occupied by commercial vehicles and used as a parking area for commercial vehicle drivers. These streets were not designated as official truck parking areas but became popular with the reduction of our existing commercial vehicle parking locations in that area. The occupation of these streets at their facilities became significant operational, security, and safety matters for them to the point that both P&G and Floor and Décor's executive regional teams flew in from their headquarters to meet with staff to discuss their major concerns. Ultimately, we had to employ strict and routine police enforcement of the area and removed all vehicular parking on Cosmos Street and a portion of Krameria Avenue between Heacock Street and Cosmos Street to reduce operational impacts to their facilities and the potential safety and vehicular conflicts. We have not received any complaints from the businesses since we implemented the changes in 2021.

Duke Realty – (Concord Way and Revere Place)

Similar to P&G and Floor and Décor, the streets adjacent to the intersection of Heacock Street and Iris Avenue were also heavily occupied by commercial vehicle parking. Duke Realty is the current owner, and their facility is adjacent to Concord Way, Revere Place, and a portion of Heacock Street. Due to the misuse and multiple code violations at the site, such as trash dumping, loitering, double parking, and the servicing of vehicles in the public right-of-way, on September 7, 2016, the Traffic Safety Commission recommended that the designated commercial vehicle parking at this location be removed. The item passed unanimously and there have been no issues reported since the action.

Cardinal Glass Industries

Most recently, Cardinal Glass Industries located at the intersection of Heacock Street and Cardinal Avenue has been impacted by the parking and loitering of commercial vehicles as they continually dispose of their trash and hazardous waste near their facility. As a result of these violations, management from Cardinal Glass met with Mayor Cabrera on May 23, 2023, to discuss these issues at length. Cardinal Management pointed out that these violations are a direct result of the loitering of commercial vehicles who are also blocking the employee and delivery driveways, which presents an unsafe condition by blocking the motorists' line-of-sight. To mitigate these issues, several no-dumping signs and red curb were installed near the driveways prohibiting dumping and restricting commercial vehicles from parking near the driveways, therefore, eliminating the line-of-sight issue. The management was satisfied, and the street is operating as intended.

Travel Lane Reduction

In addition to the issues stated by the businesses, there may be additional complaints we will receive from the building's occupants and management once commercial vehicles begin occupying the street. The current street width of Prologis Lane is 40 feet wide, which can afford commercial vehicle parking on both sides of Prologis Lane. This would allow an eight-foot parking space for commercial vehicles and a 12-foot travel lane for motorists to navigate the street. Our experience and complaints we received from areas of similar conditions is that the road may seem too narrow or compacted for the average driver to safely negotiate.

Truck Route

Prologis Lane is not connected to a truck route. The nearest truck routes are Moreno Beach Drive from the 60 Freeway to Alessandro Boulevard and Redlands Boulevard from the 60 Freeway to the northern city limits. In order to access Prologis Lane, commercial vehicle drivers will have to drive on Eucalyptus Avenue, which is not a designated truck route to get to this area to park. There are no alternative routes or roads for commercial drivers to use to access Prologis Lane.

Police Support

Staff also reached out to our commercial vehicle enforcement officers to determine if they have issues with Prologis Lane being designated as a commercial vehicle parking area. Understanding the need to provide additional areas for commercial vehicle drivers, the police department is in full support of this and any area in the vicinity as commercial vehicle parking. (Please see their email for reference.)

SUMMARY:

- There is no available parking for commercial vehicle drivers east of Heacock Street.
- Prologis Lane is strategically located in an area where commercial vehicle activity exists and is nearby many warehouses, distribution centers, two truck routes, and the 60 Freeway.
- There is strong opposition expressed by management from Santa Fe Warehouse and Mainfreight which are adjacent to Prologis Lane.
- There is a concern regarding travel lane reduction.
- The Police Department is in support of the parking.
- Prologis Lane is not connected to a truck route.

RECOMMENDATION:

Transportation Engineering recommends not making Prologis Lane a truck parking location.

From: [Smith, Angie](#)
To: [Edward Init](#)
Subject: Prologis Way - Truck Parking
Date: Wednesday, June 7, 2023 4:30:30 PM
Attachments: [image001.png](#)

Warning: External Email – Watch for Email Red Flags!

Hello Edward,

You had asked for feedback on using the Prologis Way cul-de-sac as a truck parking area. Overall, we are not in favor of this area being used as a truck parking area. In similar situations, we have seen these kinds of uses significantly increase the trash and damage to the area. That is a cost that Prologis would likely have to take on. Parking trucks here will also encourage normal cars to park here and we are already having a lot of issues with theft and transients. The 28025 building already has a guard 24/7 and still has issues with trespassing/theft. There might also be some concern for the person that owns the property at the end of the cul-de-sac. If that parcel is ever developed, these trucks would be in the way of the only entrance to that property. Please let me know if you need anything else from me. Thank you.

Angie Smith | Real Estate & Customer Experience, Manager

CalDRE License # 02129946

3546 Concourse St., Suite 100 | Ontario | California | 91764 | United States of America

Direct +1 (909) 673-8728 | asmith3@prologis.com

www.prologis.com | Follow us on [LinkedIn](#) and [Twitter](#)



The information transmitted, including any attachments, is intended only for the person or entity to which it is addressed and may contain confidential and/or privileged material. Any review, retransmission, dissemination or other use of, or taking of any action in reliance upon, this information by persons or entities other than the intended recipient is prohibited, and all liability arising therefrom is disclaimed. If you received this in error, please contact the sender and delete the material from any computer.

From: [Amelia Williamson](#)
To: [Edward Init](#)
Cc: [Henry Martinez](#)
Subject: RE: Prologis Lane - MAINFREIGHT
Date: Friday, June 16, 2023 12:50:07 PM
Attachments: [image001.png](#)

Warning: External Email – Watch for Email Red Flags!

Hi Edward,

The concern would probably be around safety and security. We have had many issues with yard break-ins and a few other things in the past, and bringing more people to the area does bring some concern.

Regards,

Amelia Williamson | Branch Manager, Warehousing | Mainfreight Inc.
 28015 Eucalyptus Ave, Moreno Valley, CA | D +1 951 419 6290 | C+1 908.205.4570 |
Amelia.Williamson@mainfreightusa.com | www.mainfreightusa.com
 • Supply Chain Logistics • Domestic, International, Air, Ocean • Customs Brokerage

"The Best preparation for good work tomorrow is to do good work today."

From: Henry Martinez <Henry.Martinez@mainfreight.com>
Sent: Friday, June 16, 2023 1:30 PM
To: Amelia Williamson <Amelia.Williamson@mainfreight.com>
Subject: FW: Prologis Lane - MAINFREIGHT

FYI

Henry Martinez | Operations Manager : Warehousing | Mainfreight Inc.
 28015 Eucalyptus Ave, Moreno Valley, CA, 92555 | D: (951) 419-6295 EXT: 121295 M:(562) 233-4095
henry.martinez@mainfreight.com | www.mainfreight.com
 • Supply Chain Logistics • Domestic, International, Air, Ocean • Customs Brokerage •

For the latest information on COVID-19 please click on this link.
<https://www.mainfreight.com/global/en/news/air-and-ocean-service-announcement-%7C-coronavirus-covid-19-update.aspx>

From: Edward Init <edwardi@moval.org>
Sent: Thursday, June 15, 2023 3:12 PM
To: Henry Martinez <Henry.Martinez@mainfreight.com>
Cc: Wei Sun, T.E., PTOE <weis@moval.org>
Subject: Prologis Lane - MAINFREIGHT

Mr. Martinez,

Thank you for taking my call. Again, my name is Edward Init and I am an engineer in the City of

Attachment: Attachments from Prologis Lane Study Final (6393 : REPORT OF EVALUATING POTENTIAL COMMERCIAL VEHICLE PARKING ON

Moreno Valley’s Traffic Engineering Division. The purpose of my email is to open communications with you and your management regarding the City’s plan to designate Prologis Lane as a designated commercial vehicle parking area. Currently, Prologis Lane has No Parking Anytime signs preventing motorists from parking on the street. With this designation, commercial vehicles will be allowed to park unrestricted except for the designated street sweeping days. We are reaching out to you and would like to hear your thoughts, and concerns, or provide you with additional information if needed.

If you or your management can kindly respond to this email and share any feedback, I would appreciate it.

Thank you,

Edward Init
Assistant Engineer
Public Works
City of Moreno Valley

p: [951.413.3152](tel:951.413.3152) | e: edwardi@moval.org w: www.moval.org
14177 Frederick St., Moreno Valley, CA, 92553



From: [Loucks, Christopher](#)
To: [Edward Init](#)
Subject: Re: Truck Parking on Prologis Way
Date: Thursday, May 25, 2023 11:13:17 AM
Attachments: [image736051.png](#)

Warning: External Email – Watch for Email Red Flags!

We are good with Prologis Way being a truck parking area. In fact any of the streets over tin that area.

Deput Chris Loucks

From: Edward Init <edwardi@moval.org>
Sent: Friday, May 19, 2023 2:40 PM
To: Loucks, Christopher <cloucks@riversidesheriff.org>
Cc: Wei Sun, T.E., PTOE <weis@moval.org>
Subject: Truck Parking on Prologis Way

CAUTION: This email originated from outside the **Riverside Sheriff** email system.
DO NOT click links or open attachments unless you recognize the sender and know the content is safe.

Hello Chris,

The City is considering expanding commercial vehicle parking and is in the process of determining if Prologis Way would be a suitable location to provide truck drivers with an alternative location that is close to the warehouses by the 60 freeway. Do you have an opinion, support, or have issues with this designation? Your feedback is highly appreciated.

Please let me know, thank you.

Sent from my iPhone 13 Pro Max
Edward Init
Assistant Engineer
Public Works
City of Moreno Valley
p: 951.413.3152 | e: edwardi@moval.org w: www.moval.org
14177 Frederick St., Moreno Valley, CA, 92553



Attachment: Attachments from Prologis Lane Study Final (6393 : REPORT OF EVALUATING POTENTIAL COMMERCIAL VEHICLE PARKING ON



Report to City Council

TO: Mayor and City Council

FROM: Melissa Walker, Public Works Director/City Engineer

AGENDA DATE: October 17, 2023

TITLE: AUTHORIZATION TO AWARD AGREEMENTS TO CAV CONSULTING, HR GREEN PACIFIC, AND CWE TO PROVIDE PROFESSIONAL CONSULTING SENIOR ENGINEER AND ADMINISTRATIVE SERVICES TO CAPITAL PROJECTS DIVISION OF THE PUBLIC WORKS DEPARTMENT

RECOMMENDED ACTION

Recommendations:

1. Award Agreements for Professional Consultant Services with CAV Consulting, HR Green Pacific, and CWE to provide as-needed Consultant Senior Engineer and Administrative Services related to management and implementation of Capital Improvement Plan (CIP) projects for the Capital Projects Division; and
2. Authorize the City Manager to execute Agreements for Professional Consultant Services with CAV Consulting, HR Green Pacific, and CWE in the combined amount of approximately \$300,000 per year for the total aggregate not-to-exceed amount of \$900,000 over the entire three-year term of the agreements, subject to the approval of the City Attorney; and
3. Authorize the issuance of Purchase Orders to CAV Consulting, HR Green Pacific, and CWE once the Agreements have been signed by all parties using budget approved for each project and State Gas Tax as supplement funding; and
4. Authorize the City Manager to execute any subsequent Amendments to the Agreements with CAV Consulting, HR Green Pacific, and CWE within Council approved annual budgeted amounts for CIP projects, including the authority to authorize the associated purchase orders in accordance with the terms of the Agreement, subject to the approval of the City Attorney.

SUMMARY

This report recommends approval of the Agreements for Professional Consultant

Services with CAV Consulting, HR Green Pacific, and CWE to provide senior engineer and related administrative services for the Capital Projects Division in managing and implementing various Capital Improvement Plan (CIP) projects. These services are funded by budgets allocated for projects as included in the adopted CIP Fiscal Years 23/24 and 24/25.

DISCUSSION

With new projects added to the CIP Fiscal Years 23/24 and 24/25 in response to demands for infrastructure improvements and upgrading, the Capital Projects Division is in need of additional assistance from consultants to manage the current workload. Capital Projects Division currently manages its own assigned CIP projects and assists in implementing projects from other departments and divisions citywide including Parks and Community Services, Transportation Engineering, Fleet and Facilities and Storm Water Management. As-needed assistance from consultants with their experience and expertise has been resourceful and helpful in managing critical projects and ensuring on-time delivery of the projects. Consultants could also assist with project-related administrative duties including contracts processing, invoices and labor compliance reviews processing, grant applications preparation, and request for proposals and bid documents preparation.

In August 2023, Request for Proposals (RFP) for On-Call Professional Consultant Services for senior engineer and administrative services was posted on City's online advertising portal. The City received four (4) proposals in response to the RFP. Review of the proposals resulted in top three consultants: CAV Consulting, HR Green Pacific, and CWE who are highly qualified with diverse expertise in engineering and project/construction management to perform the requested services. This would provide the City with the flexibility in assigning certain projects and special tasks to the consultants with appropriate expertise to manage and complete. The consultants would manage the projects through different phases including preliminary engineering, environmental clearance, final design, advertising, and construction.

The RFP and consultant selection processes were completed in accordance with the City's Municipal Code requirements for professional services procurement. Staff recommends approval of the agreements with CAV Consulting, HR Green Pacific, and CWE to provide senior engineer and related administrative services for the Capital Projects Division.

ALTERNATIVES

1. Approve the recommended actions as presented in this staff report. This alternative will allow for the requested senior engineering and related administrative services to be performed by the consultants in a timely manner avoiding delays in project implementation schedules.
2. Do not approve the recommended actions as presented in this staff report. Staff does not recommend this alternative, as it would result delay in project delivery of

various CIP projects.

FISCAL IMPACT

The requested senior engineer and related administrative services to be provided by CAV Consulting, HR Green Pacific, and CWE are funded by budgets allocated for projects as included in the adopted CIP Fiscal Years 23/24 and 24/25. State Gasoline Tax (Fund 2000) is to be used up front for opening associated purchase orders to pay for consultant's costs that will be allocated back to appropriate project budgets which the consultant had worked on.

NOTIFICATION

Publication of agenda

PREPARATION OF STAFF REPORT

Prepared By:
Quang Nguyen, P.E.
Capital Projects Principal Engineer

Department Head Approval:
Melissa Walker, P.E.
Public Work Director/City Engineer

Concurred By:
Harold Zamora, P.E.
Engineering Division Manager/Assistant City Engineer

CITY COUNCIL GOALS

Public Facilities and Capital Projects. Ensure that needed public facilities, roadway improvements, and other infrastructure improvements are constructed and maintained.

Positive Environment. Create a positive environment for the development of Moreno Valley's future.

Community Image, Neighborhood Pride and Cleanliness. Promote a sense of community pride and foster an excellent image about our City by developing and executing programs which will result in quality development, enhanced neighborhood preservation efforts, including home rehabilitation and neighborhood restoration.

CITY COUNCIL STRATEGIC PRIORITIES

1. Economic Development
2. Public Safety
3. Library
4. Infrastructure
5. Beautification, Community Engagement, and Quality of Life
6. Youth Programs

ATTACHMENTS

To view large attachments, please click your “bookmarks”



on the left hand side of this document for the necessary attachment.

- 1. Agreement with CAV Consulting
- 2. Agreement with HR Green Pacific
- 3. Agreement with CWE

APPROVALS

Budget Officer Approval	<u>✓ Approved</u>	10/09/23 9:11 AM
City Attorney Approval	<u>✓ Approved</u>	
City Manager Approval	<u>✓ Approved</u>	10/09/23 2:36 PM

**AGREEMENT FOR
PROFESSIONAL CONSULTANT SENIOR ENGINEER AND
RELATED ADMINISTRATIVE SERVICES FOR CAPITAL PROJECTS DIVISION**

This Agreement (hereinafter, this "Agreement") is made and entered into this ____ day of _____ 2023 ("Effective Date"), by and between the City of Moreno Valley, a municipal corporation in the County of Riverside, State of California, hereinafter referred to as the "City," and **CAV Consulting**, (California corporation, partnership, sole ownership), hereinafter referred to as "Consultant."

RECITALS

WHEREAS, the City has determined it is in the public interest to proceed with the professional consultant senior engineer and administrative services hereinafter described as "WORK"; and

WHEREAS, the City has determined the WORK involves the performance of professional and technical services of a temporary nature as more specifically described in Exhibit "A" (City's Request for Proposal) and Exhibit "B" (Consultant's Proposal) hereto; and

WHEREAS, the City does not have available employees to perform the services for the WORK; and

WHEREAS, the City has requested the Consultant to perform such services for the WORK; and

WHEREAS, the Consultant is professionally qualified in California to perform the professional and technical services required for the WORK, and hereby represents that it desires to and is professionally and legally capable of performing the services called for by this Agreement;

THEREFORE, the City and the Consultant, for the consideration hereinafter described, mutually agree as follows:

**AGREEMENT FOR PROFESSIONAL CONSULTANT
SENIOR ENGINEER AND ADMINISTRATIVE SERVICES**

DESCRIPTION OF WORK

1. The WORK is described as Professional Consultant Senior Engineer and Administrative Services.

SCOPE OF SERVICES

2. The Consultant's scope of service is described on Exhibit "B" attached hereto and incorporated herein by this reference. In the event of a conflict, the City's Request for Proposal shall take precedence over the Consultant's Proposal.

3. The City's responsibility is described on Exhibit "C" attached hereto and incorporated herein by this reference.

PAYMENT TERMS

4. The City agrees to pay the Consultant and the Consultant agrees to receive a "Not-to-Exceed" fee of \$ TBD in accordance with the payment terms provided on Exhibit "D" attached hereto and incorporated herein by this reference.

TIME FOR PERFORMANCE

5. The Consultant shall commence services upon receipt of written direction to proceed from the City.

6. The Consultant shall perform the work described on Exhibit "A" in accordance with the schedule set forth in Exhibit "B" attached hereto and incorporated by this reference.

7. This Agreement shall be effective from effective date and shall continue in full force and effect date through December 30, 2026, subject to any earlier termination in accordance with this Agreement. The services of Consultant shall be completed in a sequence assuring expeditious completion, but in any event, all such services shall be completed prior to expiration of this Agreement.

8. (a) The Consultant agrees that the personnel, including the principal WORK Manager, and all subconsultants assigned to the WORK by the Consultant, shall be subject to

**AGREEMENT FOR PROFESSIONAL CONSULTANT
SENIOR ENGINEER AND ADMINISTRATIVE SERVICES**

the prior approval of the City.

(b) No change in subconsultants or key personnel shall be made by the Consultant without written prior approval of the City.

SPECIAL PROVISIONS

9. It is understood and agreed that the Consultant is, and at all times shall be, an independent consultant and nothing contained herein shall be construed as making the Consultant or any individual whose compensation for services is paid by the Consultant, an agent or employee of the City, or authorizing the Consultant to create or assume any obligation or liability for or on behalf of the City.

10. The Consultant may also retain or subcontract for the services of other necessary consultants with the prior written approval of the City. Payment for such services shall be the responsibility of the Consultant. Any and all subconsultants employed by the Consultant shall be subject to the terms and conditions of this Agreement, except that the City shall have no obligation to pay any subconsultant for services rendered on the WORK.

11. The Consultant and the City agree to use reasonable care and diligence to perform their respective services under this Agreement.

12. The Consultant shall comply with applicable federal, state, and local laws in the performance of work under this Agreement.

13. To the extent required by controlling federal, state and local law, Consultant shall not employ discriminatory practices in the provision of services, employment of personnel, or in any other respect on the basis of race, religious creed, color, national origin, ancestry, physical disability, mental disability, medical condition, marital status, sex, age, sexual orientation, ethnicity, status as a disabled veteran or veteran of the Vietnam era. Subject to the foregoing and during the performance of this Agreement, Consultant agrees as follows:

(a) Consultant will comply with all applicable laws and regulations providing that

**AGREEMENT FOR PROFESSIONAL CONSULTANT
SENIOR ENGINEER AND ADMINISTRATIVE SERVICES**

no person shall, on the grounds of race, religious creed, color, national origin, ancestry, physical disability, mental disability, medical condition, marital status, sex, age, sexual orientation, ethnicity, status as a disabled veteran or veteran of the Vietnam era be excluded from participation in, be denied the benefits of, or be subject to discrimination under any program or activity made possible by or resulting from this Agreement.

(b) Consultant will not discriminate against any employee or applicant for employment because of race, religious creed, color, national origin, ancestry, physical disability, mental disability, medical condition, marital status, sex, age, sexual orientation, ethnicity, status as a disabled veteran or veteran of the Vietnam era. Consultant shall ensure that applicants are employed, and the employees are treated during employment, without regard to their race, religious creed, color, national origin, ancestry, physical disability, mental disability, medical condition, marital status, sex, age, sexual orientation, ethnicity, status as a disabled veteran or veteran of the Vietnam era. Such requirements shall apply to Consultant's employment practices including, but not be limited to, the following: employment, upgrading, demotion or transfer; recruitment or recruitment advertising; layoff or termination; rates of pay or other forms of compensation; and selection for training, including apprenticeship. Consultant agrees to post in conspicuous places, available to employees and applicants for employment, notices setting forth the provision of this nondiscrimination clause.

(c) Consultant will, in all solicitations or advertisements for employees placed by or on behalf of Consultant in pursuit hereof, state that all qualified applicants will receive consideration for employment without regard to race, religious creed, color, national origin, ancestry, physical disability, mental disability, medical condition, marital status, sex, age, sexual orientation, ethnicity, status as a disabled veteran or veteran of the Vietnam era.

(d) If Consultant should subcontract all or any portion of the services to be performed under this Agreement, Consultant shall cause each subconsultant to also comply with

**AGREEMENT FOR PROFESSIONAL CONSULTANT
SENIOR ENGINEER AND ADMINISTRATIVE SERVICES**

the requirements of this Section 13.

14. Indemnification.

a. Design Professional Services. To the fullest extent permitted by law, including but not limited to Civil Code Section 2782.8, in performing “design professional services” as defined in Section 2782.8, the Consultant agrees to indemnify, defend, and save the City, the Moreno Valley Community Services District (CSD), and the Moreno Valley Housing Authority (MVHA), their officers, agents and employees harmless from any and all liability, claims, demands, damages, or injuries to any person, including injury to the Consultant's employees and all claims which arise from or are connected with the negligent, reckless, or willful misconduct in the performance of or failure to perform the work or other obligations of the Consultant under this RFP and/or related Agreement, or are caused or claim to be caused by the negligent acts of the Consultant, its officers, agents or employees, or its subconsultant(s) or any person acting for the Consultant or under its control or direction; provided, however, that this indemnification and hold harmless shall not include claims arising from the sole negligence, active negligence, or willful misconduct of the City, MVHA, and CSD, their officers, agents or employees; and does not apply to any passive negligence of City unless caused at least in part by Consultant.

b. Non-Design Professional Services. For all non-design professional services, Consultant shall indemnify, defend, and save the City, the Moreno Valley Community Services District (CSD), and the Moreno Valley Housing Authority (MVHA), their officers, agents and employees harmless from any and all liability, claims, demands, damages, or injuries to any person, including injury to the Consultant's employees and all claims which arise from or are connected with the performance of or failure to perform the work or other obligations of the Consultant, or are caused or claim to be caused by the acts of the Consultant, its officers, agents or employees, or its subconsultant(s) or any person acting for the Consultant or under its control

**AGREEMENT FOR PROFESSIONAL CONSULTANT
SENIOR ENGINEER AND ADMINISTRATIVE SERVICES**

or direction; provided, however, that this indemnification and hold harmless shall not include claims arising from the sole negligence or willful misconduct of the City, MVHA, and CSD, their officers, agents or employees.

c. If Consultant should subcontract all or any portion of the services to be performed under this Agreement, Consultant shall require each subconsultant to indemnify, hold harmless and defend City, CSD, Housing Authority and each of their officers, officials, employees, agents and volunteers in accordance with the terms of the preceding paragraph.

d. CalPERS Indemnity. To the fullest extent permitted by law, in addition to obligations set forth in this section, in the event that any person providing services under this Agreement is determined by a court of competent jurisdiction or CalPERS to be eligible for enrollment in CalPERS as an employee of the City, to the fullest extent of the law, Consultant shall indemnify, defend, and hold harmless City for any costs and expenses incurred by City, including without limitation, payment that City is required as a result to make to CalPERS, whether in the form of employee and/or employer contributions, taxes, or any similar obligations, as well as for the payment of any penalties and interest.

15. CalPERS Participation. As set forth in this Agreement and in the Request for Qualifications, City has an obligation to treat all persons working for or under the direction of Consultant as an independent Consultant of City and agents and employees of Consultant, and not as agents or employees of City. Consultant and City acknowledge and agree that City participates in a defined benefit plan ("CalPERS"), and that it is possible that CalPERS may find that persons providing services pursuant to this Agreement are employees of City and should be registered with the CalPERS as employees of City.

16. CalPERS Retiree Disclosure. Consultant hereby expressly agrees to clearly and conspicuously disclose to City in writing any and all persons working for Consultant who are retirees under the California Public Employees' Retirement System (CalPERS) whom receives

**AGREEMENT FOR PROFESSIONAL CONSULTANT
SENIOR ENGINEER AND ADMINISTRATIVE SERVICES**

a monthly CalPERS retirement allowance, and whom are, subject to City approval, assigned by Consultant to provide services to City under the Agreement, prior to such person performing any services hereunder. Nothing herein shall be deemed or interpreted to limit a CalPERS retiree's obligations under applicable law, rules or regulations.

Joint Cooperation. In the event that CalPERS initiates an inquiry that includes examination of whether individuals providing services under this Agreement to City are City's employees, Consultant shall within five days and share all communications and documents from CalPERS that it may legally share. In the event that either Consultant or City files an appeal or court challenge, Consultant and City each agree to cooperate with each other in responding to the inquiry and any subsequent administrative appeal or court challenge of an adverse determination.

This section shall survive termination or expiration of this Agreement.

17. Insurance.

(a) Throughout the life of this Agreement, Consultant shall pay for and maintain in full force and effect all insurance as required in **Exhibit E** or as may be authorized in writing by the City Manager or his/her designee at any time and in his/her sole discretion.

(b) If at any time during the life of the Agreement or any extension, Consultant or any of its subconsultant fail to maintain any required insurance in full force and effect, all services and work under this Agreement shall be discontinued immediately, and all payments due or that become due to Consultant shall be withheld until notice is received by City that the required insurance has been restored to full force and effect and that the premiums therefore have been paid for a period satisfactory to City. Any failure to maintain the required insurance shall be sufficient cause for City to terminate this Agreement. No action taken by City pursuant to this section shall in any way relieve Consultant of its responsibilities under this Agreement. The phrase "fail to maintain any required insurance" shall include, without limitation, notification

**AGREEMENT FOR PROFESSIONAL CONSULTANT
SENIOR ENGINEER AND ADMINISTRATIVE SERVICES**

received by City that an insurer has commenced proceedings, or has had proceedings commenced against it, indicating that the insurer is insolvent.

(c) The fact that insurance is obtained by Consultant shall not be deemed to release or diminish the liability of Consultant, including, without limitation, liability under the indemnity provisions of this Agreement. The duty to indemnify City shall apply to all claims and liability regardless of whether any insurance policies are applicable. The policy limits do not act as a limitation upon the amount of indemnification to be provided by Consultant. Approval or purchase of any insurance contracts or policies shall in no way relieve from liability nor limit the liability of Consultant, its principals, officers, agents, employees, persons under the supervision of Consultant, vendors, suppliers, invitees, consultants, sub-consultants, subconsultants or anyone employed directly or indirectly by any of them.

(d) Upon request of City, Consultant shall immediately furnish City with a complete copy of any insurance policy required under this Agreement, including all endorsements, with said copy certified by the underwriter to be a true and correct copy of the original policy. This requirement shall survive expiration or termination of this Agreement.

(e) If Consultant should subcontract all or any portion of the services to be performed under this Agreement, Consultant shall require each subconsultant to provide insurance protection in favor of City and each of its officers, officials, employees, agents and volunteers in accordance with the terms of this section, except that any required certificates and applicable endorsements shall be on file with Consultant and City prior to the commencement of any services by the subconsultant.

18. The waiver by either party of a breach by the other of any provision of this Agreement shall not constitute a continuing waiver or a waiver of any subsequent breach of either the same or a different provision of this Agreement. No provisions of this Agreement may be waived unless in writing and signed by all parties to this Agreement. Waiver of any one

**AGREEMENT FOR PROFESSIONAL CONSULTANT
SENIOR ENGINEER AND ADMINISTRATIVE SERVICES**

provision herein shall not be deemed to be a waiver of any other provision herein.

19. Consultant and subconsultants shall pay prevailing wage rates when required by the Labor Laws of the State of California. Consultant and all of Consultant's subcontractors, if any, shall pay each employee engaged in all applicable trades or occupation not less than the prevailing hourly wage rate for work of a similar character in the locality in which the public work is performed, and not less than the general prevailing rate of per diem wages for holiday and overtime work. In accordance with the provisions of Section 1770 of the California Labor Code ("Labor Code"), the Director of Department of Industrial Relations of the State of California has determined the general prevailing rates of wages and employer payments for health and welfare, pension, vacation, travel time, and subsistence pay as provided for in Labor Code Section 1773.8, apprenticeship or other training programs authorized by Labor Code Section 3093 and similar purposes applicable to the work to be done. Said wages are available through the California Department of Industrial Relations' Internet website at <http://www.dir.ca.gov/dlsr/PWD/index.htm> and are on file at City Hall, as provided in Section 1773.2 of the Labor Code. Said rates shall be posted at the WORK site where work is to be performed, in accordance with Labor Code Section 1773.2. Consultant shall access a copy of the wage rate determination and shall make all subcontractors, if any, aware of the determination. As the wage determination for each craft reflects an expiration date, it shall be the Consultant's responsibility to ensure that the prevailing wage rates of concern are current and paid. Subject to the safe harbor provisions of Labor Code Section 1775, Consultant shall forfeit to the City an amount not to exceed two hundred dollars (\$200) for each calendar day or portion thereof, as set by the Labor Commissioner in accordance with the terms of Labor Code section 1775, for each laborer, workmen or mechanics employed that is paid less than the general prevailing rate of wages herein referred to and stipulated for any work done under the proposed contract, by him, or by any subcontractor under him, in violation of the provisions of

**AGREEMENT FOR PROFESSIONAL CONSULTANT
SENIOR ENGINEER AND ADMINISTRATIVE SERVICES**

the Labor Code, and in particular, Sections 1770 to 1781 inclusive. Consultant and any and all or its subcontractors shall forfeit to the City twenty-five dollars (\$25) for each worker employed in the performance of this Agreement for each calendar day during which the worker is required or permitted to work more than eight (8) hours in any one calendar day and forty (40) hours in any one calendar week in violation of the provisions of Section 1813 of the Labor Code. In the event the total cost of the WORK is thirty thousand dollars (\$30,000.00) or more, Consultant shall further comply with provisions set forth in Labor Code Section 1777.5 pertaining to employment of properly registered apprentices, including without limitation the obligation to (i) pay employed apprentices the prevailing rate of per diem wages for apprentices in the trade to which he or she is registered and shall be employed only at the work of craft or trade to which he or she is registered; (ii) employ apprentices in at least the ratio as set forth in said section; (iii) submit contract award information to an applicable apprenticeship program; and (iv) contribute to California Apprenticeship Council.

Consultant and all subcontractors hired to perform any work under the WORK shall keep accurate payroll records, including the name, address, social security number, work classification, straight time and overtime hours worked each day and week, and the actual per diem wages paid to each worker, in accordance with Section 1776 of the Labor Code. Payroll records shall be on forms provided by the Division of Labor Standards Enforcement (“DLSE”) or in a manner containing the same information as the forms provided by the DLSE. Failure to comply with the above may result in monetary penalties to the Consultant or affected subcontractor. Payroll records shall be verified by written declaration made under penalty of perjury, that the information contained in the records is true and correct. Consultant and any and all subcontractors shall make a certified copy of all payroll records available for inspection by DLSE, the City or any member of the public and otherwise provide certified copies of such records to any of the foregoing within ten (10) days of Consultant’s and subcontractor’s receipt

**AGREEMENT FOR PROFESSIONAL CONSULTANT
SENIOR ENGINEER AND ADMINISTRATIVE SERVICES**

of written request therefor. Failure to comply with the above may result in monetary penalties, in accordance with Labor Code Section 1776(d) and (h).

Notwithstanding anything else to the contrary, Consultant hereby acknowledges that all contractors and subcontractors must be registered with the Department of Industrial Relations ("Department") pursuant to Labor Code Section 1725.5 in order to be qualified to bid on, be listed in a bid proposal, subject to the requirements of Section 4104 of the Public Contract Code, or engage in the performance of any public work contract, including this Agreement, that is subject to the payment of prevailing wages. The WORK is subject to compliance monitoring and enforcement by the Department of Industrial Relations. In accordance with Section 3700 of the Labor Code, Consultant must secure payment of compensation to all Consultant's employees. Consultant represents and warrants that Consultant is registered with the Department in the manner prescribed by the Department and has paid the requisite application fee, as required by Labor Code Section 1725.5. Moreover, prior to Consultant entering into any contracts with any subcontractor, Consultant shall obtain proof that all such subcontractors have also registered with the Department in accordance with Section 1725.5.

20. (a) The Consultant shall deliver to the [Public Works Director/City Engineer or his/her designated representative](#), fully completed and detailed WORK-related documents which shall become the property of the City. The Consultant may retain, for its files, copies of any and all material, including drawings, documents, and specifications, produced by the Consultant in performance of this Agreement.

(b) The Consultant shall be entitled to copies of all furnished materials for his files and his subconsultants, if any.

(c) The City agrees to hold the Consultant free and harmless from any claim arising from any unauthorized use of computations, maps, and other documents prepared or

**AGREEMENT FOR PROFESSIONAL CONSULTANT
SENIOR ENGINEER AND ADMINISTRATIVE SERVICES**

provided by the Consultant under this Agreement, if used by the City on other work without the permission of the Consultant. Consultant acknowledges that Consultant work product produced under this agreement may be public record under State law.

21. (a) This Agreement shall terminate without any liability of City to Consultant upon the earlier of: (i) Consultant's filing for protection under the federal bankruptcy laws, or any bankruptcy petition or petition for receiver commenced by a third party against Consultant; (ii) 10 calendar days prior written notice with or without cause by City to Consultant; (iii) City's non-appropriation of funds sufficient to meet its obligations hereunder during any City fiscal year of this Agreement, or insufficient funding for the WORK; or (iv) expiration of this Agreement. The written notice shall specify the date of termination. Upon receipt of such notice, the Consultant may continue services on the WORK through the date of termination, provided that no service(s) shall be commenced or continued after receipt of the notice, which is not intended to protect the interest of the City. The City shall pay the Consultant within thirty (30) days after the date of termination for all non-objected to services performed by the Consultant in accordance herewith through the date of termination. Consultant shall not be paid for any work or services performed or costs incurred which reasonably could have been avoided.

(b) In the event of termination due to failure of Consultant to satisfactorily perform in accordance with the terms of this Agreement, City may withhold an amount that would otherwise be payable as an offset to, but not in excess of, City's damages caused by such failure. In no event shall any payment by City pursuant to this Agreement constitute a waiver by City of any breach of this Agreement which may then exist on the part of Consultant, nor shall such payment impair or prejudice any remedy available to City with respect to the breach.

(c) Upon any breach of this Agreement by Consultant, City may (i) exercise any right, remedy (in contract, law or equity), or privilege which may be available to it under applicable laws of the State of California or any other applicable law; (ii) proceed by appropriate court action

**AGREEMENT FOR PROFESSIONAL CONSULTANT
SENIOR ENGINEER AND ADMINISTRATIVE SERVICES**

to enforce the terms of the Agreement; and/or (iii) recover all direct, indirect, consequential, economic and incidental damages for the breach of the Agreement. If it is determined that City improperly terminated this Agreement for default, such termination shall be deemed a termination for convenience.

(d) Consultant shall be liable for default unless nonperformance is caused by an occurrence beyond the reasonable control of Consultant and without its fault or negligence such as, acts of God or the public enemy, acts of City in its contractual capacity, fires, floods, epidemics, quarantine restrictions, strikes, unusually severe weather, and delays of common carriers. Consultant shall notify City in writing as soon as it is reasonably possible after the commencement of any excusable delay, setting forth the full particulars in connection therewith, and shall remedy such occurrence with all reasonable dispatch, and shall promptly give written notice to Administrator of the cessation of such occurrence.

22. This Agreement is binding upon the City and the Consultant and their successors and assigns. Except as otherwise provided herein, neither the City nor the Consultant shall assign, sublet, or transfer its interest in this Agreement or any part thereof without the prior written consent of the other.

23. A City representative shall be designated by the City and a Consultant representative shall be designated by the Consultant. The City representative and the Consultant representative shall be the primary contact person for each party regarding performance of this Agreement. The City representative shall cooperate with the Consultant, and the Consultant's representative shall cooperate with the City in all matters regarding this Agreement and in such a manner as will result in the performance of the services in a timely and expeditious fashion.

24. This Agreement represents the entire and integrated Agreement between the City and the Consultant, and supersedes all prior negotiations, representations or Agreements, either

**AGREEMENT FOR PROFESSIONAL CONSULTANT
SENIOR ENGINEER AND ADMINISTRATIVE SERVICES**

written or oral. This Agreement may be modified or amended only by a subsequent written Agreement signed by both parties.

25. Where the payment terms provide for compensation on a time and materials basis, the Consultant shall maintain adequate records to permit inspection and audit of the Consultant's time and materials charges under this Agreement. The Consultant shall make such records available to the City at the Consultant's office during normal business hours upon reasonable notice. Nothing herein shall convert such records into public records. Except as may be otherwise required by law, such records will be available only to the City. Such records shall be maintained by the Consultant for three (3) years following completion of the services under this Agreement.

26. The City and the Consultant agree, that to the extent permitted by law, until final approval by the City, all data shall be treated as confidential and will not be released to third parties without the prior written consent of both parties.

27. (a) Consultant shall comply, and require its subconsultants to comply, with all applicable (i) professional canons and requirements governing avoidance of impermissible client conflicts; and (ii) federal, state and local conflict of interest laws and regulations including, without limitation, California Government Code Section 1090 et. seq., the California Political Reform Act (California Government Code Section 87100 et. seq.) and the regulations of the Fair Political Practices Commission concerning disclosure and disqualification (2 California Code of Regulations Section 18700 et. seq.). At any time, upon written request of City, Consultant shall provide a written opinion of its legal counsel and that of any subconsultant that, after a due diligent inquiry, Consultant and the respective subconsultant(s) are in full compliance with all laws and regulations. Consultant shall take, and require its subconsultants to take, reasonable steps to avoid any appearance of a conflict of interest. Upon discovery of any facts giving rise to the appearance of a conflict of interest, Consultant shall immediately notify City of these facts

**AGREEMENT FOR PROFESSIONAL CONSULTANT
SENIOR ENGINEER AND ADMINISTRATIVE SERVICES**

in writing.

(b) In performing the work or services to be provided hereunder, Consultant shall not employ or retain the services of any person while such person either is employed by City or is a member of any City council, commission, board, committee, or similar City body. This requirement may be waived in writing by the City Manager, if no actual or potential conflict is involved.

(c) Consultant represents and warrants that it has not paid or agreed to pay any compensation, contingent or otherwise, direct or indirect, to solicit or procure this Agreement or any rights/benefits hereunder.

(d) Neither Consultant, nor any of Consultant's subconsultants performing any services on this WORK, shall bid for, assist anyone in the preparation of a bid for, or perform any services pursuant to, any other contract in connection with this WORK unless fully disclosed to and approved by the City Manager, in advance and in writing. Consultant and any of its subconsultants shall have no interest, direct or indirect, in any other contract with a third party in connection with this WORK unless such interest is in accordance with all applicable law and fully disclosed to and approved by the City Manager, in advance and in writing. Notwithstanding any approval given by the City Manager under this provision, Consultant shall remain responsible for complying with Section 25(a), above.

(e) If Consultant should subcontract all or any portion of the work to be performed or services to be provided under this Agreement, Consultant shall include the provisions of this Section 25 in each subcontract and require its subconsultants to comply therewith.

(f) This Section 25 shall survive expiration or termination of this Agreement.

28. All Plans, drawings, Specifications, reports, logs, and other documents prepared by the Consultant in its performance under this Agreement shall, upon completion of the WORK,

**AGREEMENT FOR PROFESSIONAL CONSULTANT
SENIOR ENGINEER AND ADMINISTRATIVE SERVICES**

be delivered to and be the property of the City, provided that the Consultant shall be entitled, at its own expense, to make copies thereof for its own use.

29. The laws of the State of California shall govern the rights, obligations, duties, and liabilities of the parties to this Agreement, and shall also govern the interpretation of this Agreement. Venue shall be vested in the Superior Court of the State of California, County of Riverside.

30. Consultant expressly waives any and all rights and benefits conferred upon it by the provisions of Section 1542 of the California Civil Code which reads as follows:

“A general release does not extend to claims that the creditor or releasing party does not know or suspect to exist in his or her favor at the time of executing the release and that, if known by him or her, would have materially affected his or her settlement with the debtor or released party.”

Initials

This waiver shall be effective as a bar to any and all actions, fees, damages, losses, claims, liabilities and demands of whatsoever character, nature and kind that are known or unknown, or suspected or unsuspected, including, without limitation, claims of entitlements under the California Public Employees’ Retirement System (CalPERS) that are only afforded to employees and not independent contractors. Consultant further represents and warrants that it understands this waiver and that if it does not understand this waiver, it shall seek the advice of a qualified attorney before executing this Agreement.

Consultant hereby expressly agrees to clearly and conspicuously disclose to City in writing any and all persons working for Consultant who are retirees under the California Public Employees’ Retirement System (CalPERS) whom receives a monthly CalPERS retirement allowance, which may provide services to City under the Agreement, prior to such person performing any services thereunder. Nothing herein shall be deemed or interpreted to limited a

Attachment: Agreement with CAV Consulting (6330 : AUTHORIZATION TO AWARD AGREEMENTS FOR PROFESSIONAL CONSULTING SENIOR

**AGREEMENT FOR PROFESSIONAL CONSULTANT
SENIOR ENGINEER AND ADMINISTRATIVE SERVICES**

CalPERS retiree's obligations under applicable law, rules or regulations.

SIGNATURE PAGE FOLLOWS

Attachment: Agreement with CAV Consulting (6330 : AUTHORIZATION TO AWARD AGREEMENTS FOR PROFESSIONAL CONSULTING SENIOR

IN WITNESS HEREOF, the parties have each caused their authorized representative to execute this Agreement.

City of Moreno Valley

CAV Consulting

BY: _____
Mike Lee, City Manager

BY: _____

Name: _____

Date

TITLE: _____
(President or Vice President)

Date

<u>INTERNAL USE ONLY</u>
APPROVED AS TO LEGAL FORM:
_____ City Attorney
_____ Date
RECOMMENDED FOR APPROVAL:
_____ Public Works Director/City Engineer
_____ Date

BY: _____

Name: _____

TITLE: _____
(Corporate Secretary)

Date

- Enclosures:
- Exhibit "A" – City Scope of Services
 - Exhibit "B" – Consultant Proposal
 - Exhibit "C" – City Services
 - Exhibit "D" – Terms of Payment
 - Exhibit "E" – Insurance Requirements

Attachment: Agreement with CAV Consulting (6330 : AUTHORIZATION TO AWARD AGREEMENTS FOR PROFESSIONAL CONSULTING SENIOR

EXHIBIT "A"

REQUEST FOR PROPOSAL

2023-020

PROFESSIONAL CONSULTANT SENIOR ENGINEER SERVICES

City of Moreno Valley
14177 Frederick St.
Moreno Valley, CA 92552



RELEASE DATE: August 28, 2023

DEADLINE FOR QUESTIONS: September 11, 2023

RESPONSE DEADLINE: September 18, 2023, 2:00 pm

RESPONSES MUST BE SUBMITTED ELECTRONICALLY TO:

<https://secure.procurenow.com/portal/morenovalley>

City of Moreno Valley
REQUEST FOR PROPOSAL

Professional Consultant Senior Engineer Services

- 1. NOTICE TO BIDDERS.....
- 2. SCOPE OF SERVICES
- 3. GENERAL INFORMATION
- 4. PROPOSAL CONTENT
- 5. PROSPECTIVE BIDDER QUALIFICATIONS.....
- 6. SUBMISSION OF PROPOSALS
- 7. EVALUATION AND RANKING OF PROPOSALS
- 8. AWARD
- 9. SPECIAL TERMS AND CONDITIONS.....
- 10. Vendor Questionnaire.....

Attachments:

- A - Non-Collusion Declaration
- B - Exhibit 10-O1 Consultant Proposal DBE Commitment
- C - Exhibit 10-Q Disclosure of Lobbying Activities
- D - Sample Consultant Agreement for Professional Consultant Senior Engineer Services

Attachment: Agreement with CAV Consulting (6330 : AUTHORIZATION TO AWARD AGREEMENTS FOR PROFESSIONAL CONSULTING SENIOR

1. NOTICE TO BIDDERS

1.1. Summary

The City of Moreno Valley is seeking qualified firms whose staff has in-depth experience in project management and implementation to serve as staff extension for the City's Public Works Department to manage various capital improvement plan (CIP) projects and perform project-related senior engineer and administrative duties as assigned.

You are hereby invited to submit a proposal for providing professional consultant senior engineer services for the Public Works Department. The selected consultants could be retained to serve the City for a period of three (3) years subject to the approval of the City Council.

1.2. Background

Moreno Valley was incorporated in 1984 as a General Law City, merging the communities of Moreno, Sunnymead, and Edgemont. The City operates under a Council-Manager form of government. The City Council is comprised of an elected Mayor and four Council Members elected by district. The City has a committed customer-service oriented workforce comprised of more than 450 employees who provide a wide-range of municipal services including Public Works, Economic Development, Community Development, Parks and Community Services, Financial and Management Services and Library services. The City contracts with Riverside County for Police and Fire services.

1.3. Timeline

Due Dates and RFP-Contract Award Schedule

The Request for Proposal (RFP) release, proposal review and consultant selection processes that leads to the award of a contract for the requested services are anticipated to be completed per the following schedule:

RFP Release Date	August 28, 2023
Questions & Answer Deadline	September 11, 2023, 2:00pm
Proposal Due Date	September 18, 2023, 2:00pm
Proposal Review	September 20, 2023
City Council Awards Contract	October 3, 2023
Notice to Proceed with Services	October 23, 2023

2. SCOPE OF SERVICES

2.1. General

Under general direction, the selected staff from successful firm shall provide Professional Consultant Senior Engineer Services for a contract time of up to three (3) years subject to the approval of the City Council. The duration of work shall be on an as-needed basis.

The consultant shall manage, oversee, evaluate, monitor, and participate in the management of multiple complex capital improvement plan (CIP) projects through all phases (planning, design and construction); supervise and oversee the work of professional, technical, and administrative support staff and/or other consultants; and perform other special assignment or related senior engineer and administrative duties as assigned. Depending on the workload and project needs, City anticipates a commitment of minimum of 20 hours/week up to 40 hours/week with a requirement of two (2) full days working in-person at the City Hall.

2.2. Specific Tasks and Duties

- 2.2.1 Works independently or with staff and/or other consultants to develop, implement, and monitor work plans to achieve assigned goals and objectives; contributes to development of and monitoring of performance against the division and project budgets; participates in developing, implementing and evaluating work programs, plans, processes, systems, and procedures to achieve division and City goals, objectives and performance measures consistent with the City's quality and service expectations.
- 2.2.2 Works with staff to ensure a high performance, customer service-oriented work environment which supports achieving City objectives and service expectations; provides leadership and participates in programs and activities that promote a positive employee relations environment.
- 2.2.3 Acts as Project Manager and manages, oversees, evaluates, and monitors assigned capital improvement projects through planning, design, or construction phases; prepares and maintains detailed project cost estimates and schedules; obtains all necessary regulatory approvals and permits to implement projects; responds to requests for information and clarifies and interprets engineering issues, regulations, codes, and requirements; chairs preconstruction meetings, reviews construction schedules, and prepares preconstruction meeting minutes; verifies available project funds and prepares purchase requisitions; reviews, evaluates, processes, initiates, and prepares change orders, amendments to agreements, schedule revisions, and updates, etc.; drafts reimbursement invoices to funding agencies and ensures payment; files notices of completion with County Recorder; releases retention payments to contractors; prepares and provides regular project status reports to division management; and other close-out documentation.
- 2.2.4 Participates in the selection and supervision of project consultants and contractors; prepares requests for proposals for outside services; reviews consultant plans,

- specifications, submittals, estimates, designs, drawings, and schedules of values for completeness, accuracy, scope of work, constructability, and compliance with federal, state, and local requirements; provides recommendations for acceptable alternative solutions to design errors and other issues; interviews contractor employees and verifies compliance with federal and state prevailing wage rates and notifies contractors of discrepancies; verifies rating of contractor bonds and insurance requirements and submits to City Attorney for approval; evaluates bids and recommends awarding of contracts; monitors consultant performance and inspects work for conformance with plans and specifications; assesses, identifies and facilitates complete resolution of noncompliance issues; reviews, verifies and processes consultant and contractor invoices and pay requests for payment.
- 2.2.5 Prepares complete project bid documents which include Plans, Specifications and Estimates (PS&E). Manages and participates in advertisement and bidding processes for projects; prepares bid notices; sets bid opening times and dates and attends as assigned; prepares necessary addenda; verifies bid results and bid numbers to identify errors and omissions and provides information to the City Attorney as necessary; performs detailed records and reference checks for contractors and subcontractors; prepares and submits required documentation to funding agencies to ensure compliance with bid requirements.
- 2.2.6 Coordinates project activities with other City departments and divisions, consultants, and external agencies for plan review and permitting; conducts and facilitates regular project staff meetings.
- 2.2.7 Serves as primary liaison between the City and contractors and consultants; works with contractors, consultants, and others to resolve conflicts and facilitate solutions; inspects project sites to ensure compliance with project specifications and City policies and resolve issues.
- 2.2.8 Prepares and updates a variety of complex and technical engineering project documentation, including staff reports, bid notices, project plans and specifications, requests to advertise and adopt plans and specifications, grant applications, various notices, statements of working days, final maps, bonds, agreements, right-of-way acquisitions and other documents; drafts interagency agreements for reimbursement and conveyance of easements; prepares future project cost estimates and schedules for the City's Capital Improvement Plan.
- 2.2.9 Analyzes and responds to requests for information and complaints from other public and governmental agencies, community and business groups, citizens, the media, and the public; represents the City and makes presentations at various meetings and public hearings.

- 2.2.10 Identifies, evaluates, selects, and submits grants for City Council approval; prepares and submits applications for various federal and state grant funding programs; ensures project compliance with grant requirements.
- 2.2.11 Oversees project right-of-way acquisition processes; performs research on project areas to ensure they are within existing City rights-of-way; recommends the acquisition of additional rights-of-way as necessary.

3. GENERAL INFORMATION

Proposals must be submitted electronically via the City of Moreno Valley e-Procurement System, OpenGov, **before the Due Date and Time as shown on Section 1.3 of this RFP**, at:

<https://procurement.opengov.com/portal/morenovalley>

The proposer shall provide a separate file for technical proposal and a separate file for cost proposal.

(Note: Cost proposals will not be opened during the review and rating of the technical proposals. Once the consultant ranking is made and top-ranked consultant is identified, only the cost proposal of the top-ranked consultant will be opened for review and contract negotiation purposes.)

Unless otherwise specified, proposals submitted by any other method such as hard copy, fax, or e-mail will be disqualified.

Proposals may be withdrawn on the OpenGov vendor portal prior to the scheduled submittal time and date for receipt of proposals.

Prospective bidder's are encouraged to not wait until deadline to submit proposals, as system-related questions may arise.

All questions, technical, commercial, or contractual in nature shall be directed to the Questions & Answers Section on the e-Procurement System, OpenGov. No phone calls will be allowed. Contact of the City of Moreno Valley personnel directly regarding this RFP is prohibited and may be grounds for elimination from the selection process. All questions regarding this RFP must be submitted through OpenGov no later than **the Questions & Answers Deadline as shown on Section 1.3 of this RFP**.

Bidders experiencing any technical difficulties with the bid submission process may contact OpenGov at (650) 336-7167 or utilize the chat bubble in the system. Neither the City, nor OpenGov, makes any guarantee as to the timely availability of assistance, or assurance that any given problem will be resolved by the bid submission deadline.

Right to Reject Proposals: City reserves the right to reject any and all proposals, to waive any non-material irregularities or informalities in any proposal, and to accept or reject any item or combination of items.

Execution of Agreement: If a prospective bidder is not able to execute an agreement within 10 days after being notified of selection, City reserves the right to select the next most qualified bidder or call for new proposals, whichever City deems most appropriate. (Sample template of agreement is attached).

Incorporation of RFP/Proposal: This RFP and the firm's response, including all promises, warranties, commitments, and representations made in the successful proposal will become binding contractual obligations and will be incorporated by reference in any agreement between City and prospective bidder.

Authorized Signatories: Company personnel signing the cover letter of the proposal, or any other related forms submitted must be authorized signers with the requisite authority to represent their firm and to enter into binding contracts.

Request For Proposal #2023-020
Title: Professional Consultant Senior Engineer Services

Validity of Proposals: Proposed services and related pricing contained in the proposal must be valid for a period of 60 Days after the due date.

Attachment: Agreement with CAV Consulting (6330 : AUTHORIZATION TO AWARD AGREEMENTS FOR PROFESSIONAL CONSULTING SENIOR

4. PROPOSAL CONTENT

The Consultant's Proposal shall be no more than 20 pages, excluding executive summary, resumes, dividers, and certificates. Proposals failing to provide sufficient information and assurances of performance to accurately assess each category of the required services and failing to comply with requirements and conditions of the RFP will not be given further consideration.

4.1. Executive Summary

The Consultant shall include an executive summary with general firm's information including full legal name and contact information, organizational structure (corporation, LLC, etc.), name(s) and title(s) of the principal owner(s), person(s) authorized to make commitments for your company identified in the corporate resolution, firm history and length of relevant experience, and current number of employees with emphasis on key personnel. The executive summary shall be limited to a maximum of one page.

4.2. Technical Proposal

The Consultant shall include, but not be limited to, the following items in the body of the proposal:

- 4.2.1 Proposer's approach and understanding of all necessary tasks and steps involved in completing the required services.
- 4.2.2 Responses with sufficient detail to enable City to evaluate your understanding of City's requirements, the suitability of your services and/or product(s) to meet City's requirements, the strength of your work plan, previous experience, and current workload.
- 4.2.3 A detailed work plan to reflect the methods and procedures that the proposer intends to use to provide the required services. The scope of services outlined in this RFP is only provided as a guide and does not include all the tasks as required to complete the work.
- 4.2.4 A list of deliverables or goals to be achieved for this service contract.
- 4.2.5 Procedures for perform Quality Assurance and Quality Control (QA/QC) on the services to be provided.
- 4.2.6 Related experience including relevant experience date, name of agency, and reference name/contact information.
- 4.2.7 A resource allocation matrix (exclude cost information).

4.3. Proposed Staff/Team

- 4.3.1 Information on key personnel who is expected to remain in service until completion of the contract.
- 4.3.2 Information on the back-up personnel in the event of the key personnel not available to provide the contracted services for certain short period during the contract duration.
- 4.3.3 Provide resumes of proposed staff/team members.

4.4. Required Statements

The Consultant's Proposal shall include the following:

- 4.4.1 A statement that this RFP shall be incorporated in its entirety as a part of the Consultant's Proposal.
- 4.4.2 A statement that this RFP and the Consultant's Proposal will jointly become part of the Agreement for Professional Consultant Services for this project when said Agreement is fully executed by the Consultant and the City Manager of Moreno Valley.
- 4.4.3 A statement that the Consultant's Services to be provided, and fees therefore, will be in accordance with the City's RFP except as otherwise specified in the Consultant's Proposal under the heading "ADDITIONS OR EXCEPTIONS TO THE CITY'S REQUEST FOR PROPOSAL."
- 4.4.4 A single and separate section with the heading "ADDITIONS OR EXCEPTIONS TO THE CITY'S REQUEST FOR PROPOSAL" (if needed) containing a complete and detailed description of all of the exceptions to the provisions and conditions of this Request for Proposal upon which the Consultant's Proposal is contingent and which shall take precedent over this RFP.
- 4.4.5 A statement of qualifications applicable to this project including the names, qualifications and proposed duties of the Consultant's Staff to be assigned to this project; a listing of recent similar projects completed including the names, titles, addresses and telephone numbers of the appropriate persons whom the City could contact. If one or more of the Consultant's staff should become unavailable, the Consultant may substitute other staff of at least equal competence only after prior written approval by the City.
- 4.4.6 A resource allocation matrix must be submitted with the Proposal. The resource allocation matrix must list detailed tasks in rows and the appropriate individual (Job Title Only) as well as the number of hours that these individuals will be working on each task listed, will be included in adjacent columns. The resource allocation matrix and the project design schedule are required of both the primary consultant, as well as any sub-consultant. In addition, the applicable construction support services consultant must list the type and number or hours of geotechnical tests being proposed, as well as the type and number of hours of inspection or survey work within the Proposal. Failure to do so will result in the Consultant's Proposal being deemed incomplete and it will not receive further consideration. The construction support services Consultant is not required to provide a Project Schedule with milestones.
- 4.4.7 A statement of sub-consultant's (include relief personnel) qualifications applicable to this project including the names, qualifications and proposed duties of the sub-consultant's staff to be assigned to this project; a listing of recent similar projects completed including the names, titles, addresses, and telephone numbers of the appropriate persons whom the City could contact.
- 4.4.8 A statement that the Consultant acknowledges and understands that the Consultant will not be allowed to change the sub-consultant without written permission from the City.
- 4.4.9 A statement that all charges for Consultant (construction) services is a "Not-to-Exceed Fee" which must include conservatively estimated reimbursable expenses, as submitted with and made a part of said Consultant's Proposal.
- 4.4.10 A statement that the Consultant will document and provide the results of the work to the satisfaction of the City. This may include preparation of field and final reports, or similar evidence of attainment of the Agreement objectives.
- 4.4.11 A statement that the Consultant will immediately document and notify the City of any defects or hazardous conditions observed in the vicinity of the project site prior, during, or after the construction work.

- 4.4.12 A copy of the Consultant's hourly rate schedule and a statement that said hourly rate schedule is part of the Consultant's Proposal for use in invoicing for progress payments and for extra work incurred that is not part of this RFP. An itemized cost breakdown for the work described herein must be submitted in a separate file, entitled Cost file, as part of the Consultant's Proposal submittal. All extra work will require prior approval from the City.
- 4.4.13 A statement that the Consultant will not discriminate against any employee or applicant for employment because of race, color, religion, sex, or national origin.
- 4.4.14 A statement that all federal laws and regulations shall be adhered to notwithstanding any state or local laws and regulations. In a case of conflict between federal, state or local laws or regulations the strictest shall be adhered to.
- 4.4.15 A statement that the Consultant shall allow all authorized federal, state, county, and City officials access to place of work, books, documents, papers, fiscal, payroll, materials, and other relevant contract records pertinent to this special project. All relevant records shall be retained for at least three years.
- 4.4.16 A statement that the Consultant shall comply with the Davis-Bacon Fair Labor Standards Act (40 USC 276-a through a-7), and the implementation regulations issued pursuant thereto (29 CFR Section 1, 5), any amendments thereof and the California Labor Code. Pursuant to the said regulations, entitled "Federal Labor Standards Provisions," Federal Prevailing Wage Decision" and State of California prevailing wage rates, respectively.
- 4.4.17 A statement that the Consultant shall comply with the Copeland Anti-Kickback Act (18 USC 874) and the Implementation Regulation (29 CFR 3) issued pursuant thereto, and any amendments thereof.
- 4.4.18 A statement that the Consultant offers and agrees to assign to the City all rights, title, and interest in and to all causes of action it may have under Section 4 of the Clayton Act (15 USC Sec. 15) or under the Cartwright Act (Chapter 2 [commencing with Section 16700] of Part 2 of Division 7 of the Business and Professions Code), arising from purchases of goods, services, or materials pursuant to the public works or the subcontract. This assignment shall be made and become effective at the time the City tenders final payment to the Consultant, without further acknowledgment by the parties.

4.5. [Required Forms](#)

- 4.5.1 Non-Collusion Declaration Form
- 4.5.2 Exhibit 10-O1, Consultant Proposal DBE Commitment
- 4.5.3 Exhibit 10-Q, Disclosure of Lobbying Activities

4.6. [Cost Proposal](#)

- 4.6.1 A Cost Proposal that includes all costs associated with the requested services for the anticipated service length of up to three (3) years.
- 4.6.2 A rate schedule aligned with titles in the resource allocation matrix in Technical Proposal.
- 4.6.3 The general Scope of Services outlined herein is only provided as a guide in this Request for Proposal.

4.6.4 Itemized tasks and corresponding costs must be identical to the detailed Scope of Services included as part of the Proposer’s Technical Proposal.

5. PROSPECTIVE BIDDER QUALIFICATIONS

5.1. Prospective Bidder Qualifications

The intent of this RFP is to evaluate the proposals, determine the prospective bidder's that are in the competitive range, and select proposers that will provide the highest level of professional services for City.

5.2. Minimum Qualifications:

The proposed staff who will be providing consultant senior engineer services shall have the knowledge of:

- 5.2.1 Theories, principles and practices of civil engineering design and construction.
- 5.2.2 Principles and modern techniques and commonly used materials and equipment used in design, construction, and maintenance of various public works projects.
- 5.2.3 Federal, state, and local laws, regulations, and court decisions applicable to public works projects.
- 5.2.4 Information technology and computer capabilities to perform daily engineering tasks.
- 5.2.5 Principles and practices of sound business communication, teamwork, and work ethics.

The proposed staff shall also possess the ability to:

- 5.2.6 Prepare, direct preparation of and review complex engineering designs, plans, specifications, and legal contracts.
- 5.2.7 Perform difficult technical research and analyze complex engineering and mathematical problems, evaluating alternatives and recommending or adopting effective courses of action.
- 5.2.8 Plan, organize, manage, and integrate engineering design and construction activities.
- 5.2.9 Design issues, analyze problems, evaluate alternatives, and develop sound and independent judgements and recommendations.
- 5.2.10 Understand, interpret, explain, and apply federal, state, and local policy, law, regulations, and court decisions applicable to public works project implementation.
- 5.2.11 Operate a personal computer using standard or customized software applications appropriate to assigned tasks.
- 5.2.12 Supervise and evaluate the work of professional consultants and construction contractors.
- 5.2.13 Prepare clear, concise, and comprehensive correspondence, reports, and other written materials.
- 5.2.14 Organize, set priorities, and exercise sound independent judgement within areas of responsibility.

- 5.2.15 Exercise tact and diplomacy in dealing with sensitive and complex issues and situations.
- 5.2.16 Establish and maintain effective working relationships with City management, staff, contractors, consultants, representatives of other governmental and utility agencies, business and community groups, citizens, the public and others encountered in the course of work.

5.3. Education, Training, and Licenses:

- 5.3.1 A bachelor's degree in civil engineering.
- 5.3.2 A minimum of five years of professional civil engineering experience.
- 5.3.3 At least three years' experience in a supervisory or program management capacity.
- 5.3.4 A valid California Civil Engineering License.
- 5.3.5 A valid California driver's license and the ability to maintain insurability under City's vehicle insurance policy.

6. SUBMISSION OF PROPOSALS

Written responses to the RFP must be prepared as specified in proposal content, as to form, content, and sequence. No changes to responses may be made after the submittal deadline.

The Proposal for the requested shall be uploaded to OPENGOV on or before, but no later **the Date and Time as shown on Section 1.3 of this RFP**. Any responses received after this time will not be considered by the City.

The response shall be signed by an officer, or officers, authorized to execute legal documents on behalf of the respondent.

The City reserves the right to waive informalities in any proposal, to reject any or all proposals, to reject one part of a proposal and accept the other, except to the extent that proposals are qualified by specific limitations, and to make awards to the Consultants whose proposal is most beneficial to the needs of the City. Bidders are solely responsible for on time submission of their electronic bid. The City will only consider bids that have been transmitted successfully and have been issued an ebid confirmation number with a time stamp from the Bid Management System indicating that the bid was submitted successfully. Transmission of bids by any other means will not be accepted. Bidders shall be solely responsible for informing themselves with respect to the proper utilization of the bid management system, for ensuring the capability of their computer system to upload the required documents, and for the stability of their internet service. Failure of the bidders to successfully submit electronic bids shall be at the bidders' sole risk and no relief will be given for late and/or improperly submitted bids. Bidders experiencing any technical difficulties with the bid submission process may contact OpenGov at (650) 336-7167 or utilize the chat bubble in the system. Neither the City, nor OpenGov, makes any guarantee as to the timely availability of assistance, or assurance that any given problem will be resolved by the bid submission deadline.

7. EVALUATION AND RANKING OF PROPOSALS

In accordance with the Chapter 3.12 PURCHASING City Municipal Code’s objective of selecting the most qualified consultant for providing the requested services, a Review Board which is composed of appropriate staff representatives and/or qualified outside representatives, will review the proposals received and select the most qualified firms. Review Board shall rank the prospective bidder's based upon the following criteria:

No.	Evaluation Criteria	Scoring Method	Weight (Points)
1.	<p>The Firm’s General Experience and Qualification Information (20 points)</p> <p>Information about the company (and all sub-Consultants) including professional licenses held; ability to furnish required insurance and meet stipulations of the City’s “boiler plate” agreement; details about comparable projects completed by the firm, as well as local experience; and its ability to provide the required services in an efficient and expeditious manner.</p>	0-100 Points	<p>20 <i>(20% of Total)</i></p>
2.	<p>Experience of Key Personnel (60 points)</p> <p>Background on key personnel (including all sub-consultants) qualifications, abilities, familiarity with state and federal procedures, local experience on comparable projects and length of service with the firm, reference information preferably with municipal agencies, and proven track record and depth of understanding/knowledge of the proposed staff.</p>	0-100 Points	<p>60 <i>(60% of Total)</i></p>
3.	<p>3. Project Approach/Understanding (20 points)</p> <p>Understanding of requested services and how the Consultant team plans to address them; the approach, methods, and procedures to be used on managing and implementing CIP projects; the management approach and organization necessary to complete the specific project or projects; and outline quality control measures to ensure delivery of a quality services on time, within budget that provides a cost efficient, timely and predictable execution of the project implementation.</p>	0-100 Points	<p>20 <i>(20% of Total)</i></p>

8. AWARD

- 8.1 After conclusion of the Evaluation and Ranking of Proposals processes, a Notification of Intent to Award may be sent to any prospective bidder's selected. City may make multiple awards.
- 8.2 Award is contingent upon the successful negotiation of final contract terms and the approval of City. Negotiations shall be confidential and not subject to disclosure to competing prospective bidder's unless an agreement is reached. If contract negotiations cannot be concluded successfully, City may negotiate a contract with the next best qualified prospective bidder's or withdraw the RFP. In the event City does not approve the recommendation to award, the RFP may be cancelled without any cost or obligation of City.
- 8.3 Prices are firm fixed prices during each contract period.
- 8.4 Prices shall be negotiated for each mutually exercised optional renewal period.

9. SPECIAL TERMS AND CONDITIONS

9.1. Termination

- 9.1.1 If, in the opinion of the City of Moreno Valley, the awarded consultant fails to perform or provide prompt, efficient service, the City must have the right to terminate or cancel the Agreement upon 10 calendar day's prior written notice with or without cause and pay Consultant for the value of the actual work satisfactorily performed to the date of termination.
- 9.1.2 The City of Moreno Valley must have the right to terminate or cancel the Agreement upon 30-day's written notice without cause and pay Consultant for the value of actual work satisfactorily performed to the date of termination.
- 9.1.3 These rights are in addition to any other rights that City may have available.

9.2. Public Employees Retirement Law (CalPERS)

- 9.2.1 CalPERS Indemnity. To the fullest extent permitted by law, in addition to obligations set forth in this section, in the event that any person providing services under this Agreement is determined by a court of competent jurisdiction or CalPERS to be eligible for enrollment in CalPERS as an employee of the City, to the fullest extent of the law, Consultant shall indemnify, defend, and hold harmless City for any costs and expenses incurred by City, including without limitation, payment that City is required as a result to make to CalPERS, whether in the form of employee and/or employer contributions, taxes, or any similar obligations, as well as for the payment of any penalties and interest.
- 9.2.2 CalPERS Participation. As set forth in this Agreement and in the Request for Proposal, City has an obligation to treat all persons working for or under the direction of Consultant as an independent contractor of City and agents and employees of Consultant, and not as agents or employees of City. Consultant and City acknowledge and agree that City participates in a defined benefit plan ("CalPERS"), and that it is possible that CalPERS may find that persons providing services pursuant to this Agreement are employees of City and should be registered with the CalPERS as employees of City.
- 9.2.3 CalPERS Retiree Disclosure. Consultant hereby expressly agrees to clearly and conspicuously disclose to City in writing any and all persons working for Consultant who are retirees under the California Public Employees' Retirement System (CalPERS) whom receives a monthly CalPERS retirement allowance, and whom are, subject to City approval, assigned by Consultant to provide services to City under the Agreement, prior to such person performing any services hereunder. Nothing herein shall be deemed or interpreted to limit a CalPERS retiree's obligations under applicable law, rules or regulations.
- 9.2.4 Joint Cooperation. In the event that CalPERS initiates an inquiry that includes examination of whether individuals providing services under this Agreement to City are City's employees, Consultant shall within five days and share all communications and documents from CalPERS that it may legally share. In the event that either Consultant or City files an appeal or court challenge, Consultant and City each agree to cooperate with each other in responding to the inquiry and any subsequent administrative appeal or court challenge of an adverse determination.

9.3. Managing Federal and State Funded Projects

As part of the senior engineer services, the Consultant may be assigned to manage certain federal and state funded projects under FHWA, HUD, FEMA, and/or State Bills (SB). The work and/or services to be provided by the Consultant shall comply with all pertinent local, State, and Federal laws and regulations. The Consultant, therefore, shall be legally able to perform services for Federal or State funded projects.

A contract DBE goal has not established for the purpose of this RFP. However, the Consultant is required to submit the Consultant Proposal DBE Commitment (Exhibit 10-O1) as included in this RFP along with the proposal to meet Caltrans Local Assistance DBE commitment requirements. Prior to starting to work on a Federal or State funded project, the Consultant shall submit to the City for approval the Consultant Contract DBE Commitment (Exhibit 10-O2) with the Contract DBE Goal specifically determined/approved for that project.

The Consultant shall also be required to submit the Disclosure of Lobbying Activities (Exhibit 10-Q) as included in this RFP along with the proposal.

9.4. 9.4 Indemnification

- 9.4.1 Design Professional Services. To the fullest extent permitted by law, including but not limited to Civil Code Section 2782.8, in performing “design professional services” as defined in Section 2782.8, the Consultant agrees to indemnify, defend, and save the City, the Moreno Valley Community Services District (CSD), and the Moreno Valley Housing Authority (MVHA), their officers, agents and employees harmless from any and all liability, claims, demands, damages, or injuries to any person, including injury to the Consultant's employees, and all claims which arise from or are connected with the negligent, reckless, or willful misconduct in the performance of or failure to perform the work or other obligations of the Consultant under this RFP and/or related Agreement, or are caused or claim to be caused by the negligent, reckless or willful misconduct of the Consultant, its officers, agents or employees, or its subconsultant(s) or any person acting for the Consultant or under its control or direction; provided, however, that this indemnification and hold harmless shall not include claims arising from the sole negligence or willful misconduct of the City, MVHA, and CSD, their officers, agents or employees.
- 9.4.2 For all non-design professional services, Consultant shall indemnify, defend, and save the City, the Moreno Valley Community Services District (CSD), and the Moreno Valley Housing Authority (MVHA), their officers, agents and employees harmless from any and all liability, claims, demands, damages, or injuries to any person, including injury to the Consultant's employees and all claims which arise from or are connected with the performance of or failure to perform the work or other obligations of the Consultant, or are caused or claim to be caused by the acts of the Consultant, its officers, agents or employees, or its subconsultant(s) or any person acting for the Consultant or under its control or direction; provided, however, that this indemnification and hold harmless shall not include claims arising from the sole negligence or willful misconduct of the City, MVHA, and CSD, their officers, agents or employees.
- 9.4.3 The protections in this Section shall be in addition to those set forth in Section 9.2 of this Request for Proposals.

10. VENDOR QUESTIONNAIRE

10.1. Please download the documents below, complete and upload.*

Please download the below documents, complete, and upload.

- [\[B\] Exhibit 10-O1 Consultant...](#)
- [\[C\] Exhibit 10-Q Disclosure...](#)
- [Non-Collusion Declaration.pdf](#)

*Response required



PROPOSAL for RFP

2023 - 020

**Professional Consultant Senior Engineer
Services**

PREPARED FOR

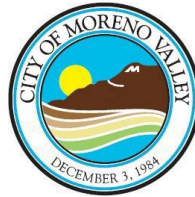

City of Moreno Valley – Purchasing Division

14177 Frederick Street

P.O. Box 88005

Moreno Valley, CA 92552

SUBMITTED BY

CAV CONSULTING

Chris A. Vogt, PE | President/Owner

17130 Van Buren Blvd., Ste 526

Riverside, CA 92504

direct 951.616.4925

cvogt@cavconsultinggroup.com

Attachment: Agreement with CAV Consulting (6330 : AUTHORIZATION TO AWARD AGREEMENTS FOR PROFESSIONAL CONSULTING SENIOR





SECTION 1: EXECUTIVE SUMMARY

September 18, 2023

Public Works Department
City of Moreno Valley 14177
Frederick Street
P.O. Box 88005
Moreno Valley, CA 92552



Re: Proposal for Professional Consultant Senior Engineer Services: Executive Summary

CAV Consulting is pleased to submit our Proposal for Professional Consultant Senior Engineer Services for the City of Moreno Valley. We understand that the City of Moreno Valley is seeking qualified firms whose staff has in-depth experience in project management and implementation to serve as staff extension for the City's Public Works Department to manage various capital improvement projects (CIP) and perform project-related senior engineer and administrative duties as assigned. We have **no** exceptions to any part of the City's scope, specifications, terms, or conditions as defined in the RFP.

CAV Consulting was formed as a Sole Proprietorship in 2020. For three (3) years we have provided services which include support and completing assignments in public works, city engineering, planning and building and safety. We currently have five (5) dedicated professional staff that bring a wealth of expertise in their respective fields with over 121 years of combined experience. Our team has extensive experience as City employees as well as working for private industry, so we know what is expected on both sides of the counter. CAV Consulting has been providing Project Management/Senior Engineer Consulting Services to Moreno Valley's Capital Improvement Projects (CIP) Division for approximately two (2) years and have completed Project Management, Interim Principal Engineer, Senior Engineer and Management Analyst Services. We successfully delivered numerous projects on schedule and under budget. We will abide by the provisions of California Assembly Bill 5 (AB-5).

The Key Personnel assigned to provide the requested services were carefully selected based on our understanding of the needs of the City. **Chris A. Vogt, PE, President/Owner** is the Principal Owner of CAV Consulting. He will serve as Principal-in-Charge, Project Manager, Senior Engineer, and Key Contact to the City of Moreno Valley. Mr. Vogt is the authorized representative of CAV Consulting and has the authority to make commitments and sign all necessary agreements. We also propose **Michelle Gonzales, Assistant Engineer** to provide backup and assistance to the Senior Engineer/Project Manager Consulting Services. In addition to the Engineering Services, we propose **Gail Smerkol, Management Analyst** to provide Analyst support services (accounting, contracts, bid support, RFP support, staff augmentation, Council Report writing, and other duties as assigned by the City. She has been providing the services for the Moreno Valley Public Works Department CIP Division for the past year.

Company Information:

CAV Consulting
Chris A. Vogt, PE | President/Owner
17130 Van Buren Blvd, Suite 526
Riverside, CA 92508

Direct: 951.616.4925 Fax: 951.776.4692 email: cvogt@cavconsultinggroup.com

The proposed services and related pricing are valid for a period of 60 days after the proposal due date.
Sincerely,

Chris A. Vogt, PE
President/Owner

Attachment: Agreement with CAV Consulting (6330 : AUTHORIZATION TO AWARD AGREEMENTS FOR PROFESSIONAL CONSULTING SENIOR



Table of Contents

Section 1: Executive Summary..... i

Section 2: Technical Proposal..... 1

Section 3: Proposed Staff/Team..... 11

Section 4: Required Statements 13

Sections 5: Required Forms 14

Sections 6: Cost Proposal 18

Attachment: Agreement with CAV Consulting (6330 : AUTHORIZATION TO AWARD AGREEMENTS FOR PROFESSIONAL CONSULTING SENIOR



SECTION 2: Technical Proposal

CAV Consulting is committed to providing the expertise and resources required to support our clients with professional services to successfully meet or exceed their goals. We provide municipal services supporting Public Works Capital Projects and Land Development, City Engineering, and Administrative Services (Management and Staff Analyst). Our team consists of professionals with years of service in the Public sector. We work well with staff in all City Departments, outside agencies, the development community, and the public to achieve your organization's goals and successfully navigate and overcome project challenges. By incorporating a "Customer Care" philosophy, we have a successful track record of the delivery of services and projects on time and within budget.

Qualifications

CAV Consulting has the experience, certifications, and expertise to assist our clients to successfully provide the Project Management for Capital Improvement Projects, as required in the City's RFP, and also many other professional services that may be required by the City. CAV Consulting formed as a Sole Proprietorship Company in September 2020. Since forming, we have grown to five dedicated and professional staff that bring a wealth of expertise in their respective fields with over 121 years of combined experience. Our diverse experience includes many years working as Public Employees and Officials. We also are fortunate to have many years of experience in the Private sector, enabling us to be well aware of the motivations and challenges from both sides of the counter. Our office is located in Riverside, CA, but we are very mobile and cover a wide range of area with our employees living throughout the Inland Empire area. Our normal hours of operation are Monday – Friday from 8:00am - 5:00pm. However, we are also available to work weekends and attend after hour meetings including City Council meetings and other City meetings as required.

We know and understand the expectations of a City because we have had those same expectations throughout our respective careers. Customer Care is of high priority to achieve success for our clients as well as all of the City's clients, businesses, and residents.

We provide the following services to cities/counties:

- ✓ **Project Management**
- ✓ **Construction Inspection**
- ✓ **Program Management**
- ✓ **Development Plan Review and Entitlements**
- ✓ **Capital Improvement Development and Implementation**
- ✓ **Engineering Plan Checking (Private Land Development and Public Capital Improvement Projects)**
- ✓ **Permit Technician**
- ✓ **Development Impact Fee Analysis**
- ✓ **Streetlight Conversion Cost Assessments**
- ✓ **Development of Department/Division Policies and Procedures**
- ✓ **Interim Public Works Director/City Engineer Services**



CAV Consulting provides expert services in areas including Public Works, City Engineering, Project Management, Program Management, and Management/Staff Analyst Services. Our team has "hands-on" experience in Project Management, CIP development and implementation, Special District development, implementation and administration, development and implementation of departmental Policies and Procedures, development and implementation of multi-year (5yr and 7yr) slurry seal programs citywide, plan checking services, development conditioning and entitlement processes, review of Final Maps and Parcel Maps, development and over-sight of Public Works Operations, establishment of Development Impact Fees, Counter Technician Services, Construction Management and Inspection, and Management Analyst Services. Our team has extensive experience as City employees as well as working for private industry, so we know what is expected on both sides of the counter.

CAV Consulting's blend of extensive and diverse experience and certifications enables us to work effectively with all City

departments for the successful delivery of projects. Our company consists of seasoned professionals, all experts in their respective fields, with a goal in ensuring the success of our client's programs and projects. The combined experience of our professionals through years of working on both sides of the counter, enable us to assure the successful delivery of projects, within schedule and budget. Being a smaller firm, we are able to focus on the City's goals and objectives.

We view the keys to serving the City of Moreno Valley as follows:

- ✓ *Providing all services in a responsive and transparent manner*
- ✓ *Assigning high quality, experienced staff and maintain consistency*
- ✓ *Coordinating effectively with other City departments and outside agencies*
- ✓ *Providing a high level of customer care to ensure success for internal and external customers*
- ✓ *Full and open communication so there are no surprises*

CAV Consulting personnel have extensive experience in the development and delivery of Public Works Capital Improvement projects and Land Development projects throughout their careers. Their expertise includes theories, principles and practices of civil engineering design and construction; principles and modern techniques and commonly used materials and equipment used in design, construction, and maintenance of various public works projects; federal, state, and local laws, regulations, and court decisions applicable to public works projects; Information Technology and computer capabilities to perform daily engineering tasks; and principles and practices of sound business communication, teamwork, and work ethics.

The proposed staff also have extensive experience in the preparation and review of complex engineering designs, plans, specifications and legal contracts; performing difficult technical research and analyzing complex engineering and mathematical problems, evaluating alternatives and recommending or adopting effective courses of action; the planning, organizing, managing, and the integration of engineering design and construction activities; resolving design issues; analyzing problems, evaluation of alternatives, and developing sound and independent judgements and recommendations; understanding, interpreting, explaining, and applying federal, state, and local policy, law, regulations, and court decisions applicable to public works project implementation; operating a personal computer using standard or customized software applications appropriate to the assigned tasks; supervise and evaluate the work of professional consultants and construction contractors; the preparation of clear, concise, and comprehensive correspondence, reports, and other written materials; organize, set priorities, and exercise sound independent judgement within areas of responsibility.

Due to CAV Consulting's philosophy of a collaborative "Teamwork" approach to the delivery of projects, all of the proposed professionals exercise tact and diplomacy in dealing with sensitive and complex issues and situations. Establish and maintain effective working relationships with City management, staff, contractors, consultants, representatives of other governmental and utility agencies, business and community groups, citizens, the public and others encountered in the course of work.

We have reviewed the City of Moreno Valley's "Sample Professional Services Agreement" included with the RFP and we are able to enter into that Agreement.

CAV Consulting Strengths

Cities are continuing to face staffing challenges; however, the demand for project delivery and services continue to increase. CAV Consulting can fulfill those City needs with our experienced professionals. More importantly, we can provide those services on an as-needed basis. This provides much needed support to the Cities based on their current demands without the additional liability the City would face with full time staff. We adjust service levels to meet the City's needs.

All of our staff have held executive management, senior level, associate level, and staff positions with numerous California cities including former Public Works Directors, City Engineers, Projects Managers, Construction Managers, Senior Engineers, Plan Check Engineers, Public Works Inspectors, Permit Technicians, and Management/Staff Analysts. Our experience, Licensing, Certifications, and training is important since serving in the capacity of a local agency representative requires credibility and expertise in working with the community and the City's customers.

We bring the following philosophies and work ethic to our Clients:

- ✓ **Customer Care Service.** Our philosophy is that every person we have contact with is considered a customer. It is important that each person we come in contact with knows that we believe their project or issue is very important to the City. We pride ourselves in providing a level of service that will meet or exceed our client's expectations.
- ✓ **Correct Staff Assigned for Services Needed.** We provide experienced staff with the correct licensing, certifications, training and experience to effectively and efficiently deliver projects and top-quality services.
- ✓ **Effective Coordination with all City Staff, outside Agencies, the Development Community and the Public.** Our staff have effectively communicated and coordinated with other City divisions and departments and all City Clients including the public throughout our careers. The City staff is a team and should not have to deal with Departmental barriers. Our Philosophy is the success of the City's customers ultimately results in the overall success of the City and the Community.
- ✓ **Project Controls.** We closely monitor the projects and services we provide to the City to stay within the Local, State and Federal requirements, including but not limited to, the City's Municipal Code, California Contract Code, General Code, and City Ordinances. Our experience and attention to details allows us to deliver projects within budget and schedule. We proactively communicate with the City Staff to head off any "surprises" that may occur during a project.

Our staff has the experience at working in a municipal environment, developing positive working relationships with affected parties, and supporting both internal and external customers to deliver projects and services within budget and schedule.

Disclosure/Company Certifications

There **ARE NO** conditions such as bankruptcy, pending litigation, planned office closures, impending mergers, contract defaults, and organizational conflicts of interest that may affect the ability of CAV Consulting to perform the required duties as defined in the Request for Proposals issued by the City.

Exceptions

We have thoroughly reviewed the RFP issued by the City including the City's standard Professional Services Agreement and accept all terms and conditions therein. We have no proposed modifications to the documents

Understanding of the Scope of Services

CAV Consulting thoroughly reviewed the City's Request for Proposals (RFP) issued on August 28, 2023, and Addendum 1 and Addendum 2, both posted on August 28, 2023. We commit that CAV Consulting will adhere to the provisions described in the City's RFP without modification. Since CAV Consulting has been providing these services to the City of Moreno Valley since 2021, we currently have been maintaining in force all licenses, insurance, documents and permits as are required by law, including a City of Moreno Valley's business license.

CAV Consulting understands that the City is looking for an experienced and qualified Consultant Firm to provide Senior Engineer/Project Management Consultant Services for the City's Public Works Department, Capital Projects Division. Under general direction of the City, the consultant shall manage, oversee, evaluate, monitor, and participate in the management of multiple complex capital improvement plan (CIP) projects through all phases (planning, design and construction); supervise and oversee the work of professional, technical, and administrative support staff and/or other consultants; and perform other special assignment or related senior engineer and administrative duties as assigned. Depending on the workload and project needs, City anticipates a commitment of minimum of 20 hours/week up to 40 hours/week with a requirement of two (2) full days working in-person at the City Hall. The services requested are for the overall project management from initial project development through the end of construction and project closeout. These specific tasks and duties include but are not limited to the following:

1. Work independently or with staff and/or other consultants to develop, implement, and monitor work plans to achieve assigned goals and objectives; contribute to development of and monitoring of performance against the division and project budgets; participate in developing, implementing and evaluating work programs, plans, processes, systems, and procedures to achieve division and City goals, objectives and performance measures consistent with the City's quality and service expectations.
2. Work with staff to ensure a high performance, customer service-oriented work environment which supports achieving City objectives and service expectations; provide leadership and participate in programs and activities that promote a positive employee relations environment.

3. Act as Project Manager and manage, oversee, evaluate, and monitor assigned capital improvement projects through planning, design, and/or construction phases; prepare and maintain detailed project cost estimates and schedules; obtain all necessary regulatory approvals and permits to implement projects; respond to requests for information and clarify and interpret engineering issues, regulations, codes, and requirements; chair preconstruction meetings, review construction schedules, and prepare preconstruction meeting minutes; verify available project funds and prepare purchase requisitions; review and evaluate processes, initiate and prepare change orders and amendments to agreements, schedule revisions and updates, etc.; draft reimbursement invoices to funding agencies and ensure payment; draft and file the Notice of Completion with the County Recorder; coordinate the release of retention payments to contractors; prepare and provide regular project status reports to division management; and complete other required close-out documentation.
4. Participate in the selection and supervision of project consultants and contractors; prepare requests for proposals for outside services; review consultant plans, specifications, submittals, estimates, designs, drawings, and schedules of values for completeness, accuracy, scope of work, constructability, and compliance with federal, state, and local requirements; provide recommendations for acceptable alternative solutions to design errors and other issues; interview contractor employees and verify compliance with federal and state prevailing wage rates and notify contractors of discrepancies; verify rating of contractor bonds and insurance requirements and submit to City Attorney for approval; evaluate bids and recommend awarding of contracts; monitor consultant performance and inspect work for conformance with plans and specifications; assess, identify and facilitate complete resolution of non-compliance issues; review, verify and process consultant and contractor invoices and pay requests for payment.
5. Prepare complete project bid documents which include Plans, Specifications and Estimates (PS&E). Manage and participate in advertisement and bidding processes for projects; prepare bid notices; set bid opening times and dates and attend as assigned; prepare necessary addenda; verify bid results and bid numbers to identify bid errors and omissions and provide information to the City Attorney as necessary; perform detailed records and reference checks for contractors and sub-contractors; prepare and submit required documentation to funding agencies to ensure compliance with bid requirements.
6. Coordinate project activities with other City departments and divisions, consultants, and external agencies for plan review and permitting; conduct and facilitate regular project staff meetings.
7. Serve as primary liaison between the City and contractors and consultants; work with contractors, consultants, and others to resolve conflicts and facilitate solutions; inspect project sites to ensure compliance with project specifications and City policies and resolve issues.
8. Prepare and update a variety of complex and technical engineering project documentation, including staff reports, bid notices, project plans and specifications, requests to advertise and adopt plans and specifications, grant applications, various notices, statements of working days, final maps, bonds, agreements, right-of-way acquisitions and other documents; draft interagency agreements for reimbursement and conveyance of easements; prepare future project cost estimates and schedules for the City's Capital Improvement Plan. Analyze and respond to requests for information and complaints from other public and governmental agencies, community and business groups, citizens, the media, and the public; represent the City and make presentations at various meetings and public hearings.
9. Analyze and respond to requests for information and complaints from other public and governmental agencies, community and business groups, citizens, the media, and the public; represents the City and make presentations at various meetings and public hearings.
10. Identify, evaluate, select, and submit grants for City Council approval; prepare and submit applications for various federal and state grant funding programs; ensure project compliance with grant requirements.
11. Oversee project right-of-way acquisition processes; perform research on project areas to ensure they are within existing City rights-of-way; recommend the acquisition of additional rights-of-way as necessary.

Approach to Project Management for Capital Improvement Projects

The challenges in delivering Capital Projects within the City's schedule and budget are ever increasing with diminishing resources within the City. We believe Project Management starts with the complete understanding of the City's goals and the constraints of the project's funding sources and schedules. For these reasons, it is imperative that a strong project manager have a full understanding of all aspects of each project and the potential hurdles that may be encountered. Our philosophy is to assign each project to a highly skilled and experienced project manager that will remain on each assignment from the beginning to final completion.

This means complete ownership of all project aspects including project development, funding/budgeting, selection and oversight of consultants, coordination with staff, project delivery, and final closeout. This approach ensures the institutional knowledge and continues the momentum throughout the project by providing a consistent project manager. Full communication throughout the project is key.

Our team is successful in delivering Capital Improvement Projects by fostering an environment of teamwork, collaboration, and cooperation with all stakeholders in a project. We have discovered that treating each of the participants in the project, from City staff through design team and ultimately the construction contractor, as part of the project team, creates an atmosphere of cooperation in obtaining a common goal. That goal is the successful completion of a project within budget and schedule with minimal claims. Too many times we have witnessed the failure of the project due to the "us against them" attitude between the contracting agency and the successful bidders on a project. We have been able to avoid this through partnering at the project beginning.

CAV Consulting fully understands what is required for Project Management services since our staff has served a number of municipalities in Southern California in a similar capacity. We provide a seamless integration of municipal service professionals in support of public agencies. With increasing demands for project delivery, along with decreasing budgets and resources, Cities are faced with the challenge of providing capable and experienced individuals to manage and coordinate their projects and to ensure proper completion according to the local, state and federal policies and procedures. Full communication with all parties involved in each project is essential, as well as complete and accurate documentation. An understanding of the existing policies and procedures and positive working relationships with the key personnel is also essential for successful project delivery within schedule and budget.

We propose to perform the following:

- ✓ *Develop project descriptions and scopes to determine budgets and delivery schedules*
- ✓ *Assist in the identification and procurement of necessary regulatory permits*
- ✓ *Prepare necessary internal communications to provide the City with regular status updates regarding project schedule, budgets, potential issues, and other items of interest or concern*
- ✓ *Prepare City Council staff reports, technical memoranda, or issue papers on projects*
- ✓ *Conduct project outreach to external stakeholders as directed by the City*
- ✓ *Manage the design team during the preparation of final plans, specification, and estimates*
- ✓ *Develop, advertise, rate/rank, negotiate, and select Consultant support services (Construction Management, Inspection, Geotechnical, ROW Services... etc.)*
- ✓ *Manage project bidding and oversee construction support and construction management/inspection*
- ✓ *Complete background checks and ensure all bids and proposals have the proper documents and insurances*
- ✓ *If required, ensure the process is performed in adherence to Federal Agency (i.e. FHWA/FTA) guidelines*
- ✓ *Manage and coordinate with the Right-of-Way Team which handles rights-of-way negotiation and acquisition assistance*
- ✓ *Continually monitor and track schedules and budget throughout the project*
- ✓ *Coordinate and chair the pre-construction meeting*
- ✓ *Draft and issue the project Notice to Proceed (NTP)*
- ✓ *Coordinate with the City's Contract Compliance Consultant throughout the project*
- ✓ *Coordinate and participate in weekly construction meetings throughout the project*
- ✓ *Review and approve or reject invoices from Contractor and consultants*
- ✓ *Communicate project status with City Management on a weekly basis (at a minimum)*
- ✓ *Coordinate the project close-out upon completion.*

- ✓ *Draft and record the Notice of Completion*

We take the following approach to all projects:

Review of the Original Project Scope, Budget, and Schedule: Many CIP projects do not begin until months, sometimes years, after they are originally developed. Items such as the original project cost estimates, municipal regulations and standards, and physical changes to the project site may have occurred prior to advertising the project for bid. We have even experienced times when utilities may not have been coordinated and soft-cost may not have been included in the project budget, requiring updates to the project scope, budget and schedule. CAV Consulting begins each project by reviewing the existing budget, schedule and goals of the City to minimize impacts to the project that may occur if the former listed issues are not addressed and resolved. We then work with the City to identify additional funding sources if necessary and address any of the project parameters that may have changed from the project inception. We will work with the City as directed to develop an outreach plan to ensure that the project addresses the community sensitivities, values, and needs.

Request for Proposals (RFPs) for Professional Services: We will provide support services to the City during the Project Development and Design Process including the following:

- ✓ *Draft RFPs for advertisement by the City*
- ✓ *Work with the City to Develop Criteria for Rating the Proposals*
- ✓ *Coordinate with the City to Form a Proposal Review and Rating Panel*
- ✓ *Coordinate the Review of the Submitted Proposals with the Selected Panel*
- ✓ *Coordinate and Conduct Interviews with the Top Ranked Proposers (if needed)*
- ✓ *Draft City Council Report(s) for Professional Contract(s) Award*
- ✓ *Work with the Construction Manager and Inspector to Complete a Constructability Review of the Plans and Specifications prior to bidding the Project*
- ✓ *Coordinate the Constructability Review comments with the Design Consultant to ensure they are addressed*

Bidding and Construction Support: We will provide support services to the City during the bidding process including the following:

- ✓ *Coordinate with the Design Consultant to Review and prepare responses to RFI's*
- ✓ *Coordinate the Review of Contractor submittals and shop drawings for compatibility with design*
- ✓ *Coordinate the Bid Opening with the City and Bidders*
- ✓ *Review the Submitted Bids to determine the Low Responsible Bidder*
- ✓ *Check the Contractor's Credentials, Licenses, and References*
- ✓ *Draft a City Council Report for Project Award*
- ✓ *Work with the Construction Manager to Conduct the Preconstruction Conference*

During construction, we will provide supplemental support to the City including:

- ✓ *Attend weekly Construction Team meetings as the City Representative*
- ✓ *Review and provide recommendations of change order proposals as negotiated by the Construction Manager*
- ✓ *Performing final review/ evaluation and assisting with the preparation of punch list for work deficiencies*
- ✓ *Draft the City Council Staff Report to approve the Final Adjusting Change Order, Authorize the Filing of the Notice of Completion and Release of the Remaining Retention*
- ✓ *Assure the completion of the record drawings by the Design Consultant based upon the redlined set of as-built plans provided by the Contractor*

Communication with City: Complete communication with the City is critical to minimize surprises and deliver a project successfully within budget and schedule. We will continually bring urgent project issues to the City, along with recommended solutions. We also continually communicate with the Project team and the City as follows:

- ✓ *Weekly meetings with the City to review staff report agendas, CIP procedural or program issues*
- ✓ *Weekly project status meetings with the Project Management staff to review project status*
- ✓ *Regular meetings of Project Development Teams on key capital projects*

- ✓ *Discuss and resolve conflicts in the field with the City and the Project Team*

Managing Project Budget and Schedule: Our Project Managers carefully monitor project budgets and schedules weekly throughout the project. We closely track the work of all members of the project team to ensure budgets and schedules are adhered to. The Contractor is directed to provide the schedule of work indicating the Project Critical Path items. After the schedule is secured, the Project Manager and Construction Manager review the schedule to determine its viability and coordinate issues that might arise that may be unknown to the Contractor. After approval of the schedule, and approval by the City, the Notice to Proceed will be issued to the Contractor. Our Project Manager monitors the team members to ensure the work is done within the scope of services and the Project remains within the approved budget and schedule.

Work with Utility Agencies on Relocations: CAV Consulting will work with the Construction Manager and Contractor to coordinate with Utilities that are affected by the Project to properly address all areas of conflict. This will minimize project delays and cost over-runs during the construction process. It will also protect newly constructed infrastructure and minimize the impacts to the community.

It is good practice to start coordination with Utility Companies during the early development stages of a project and continue coordination and communication throughout all project stages.

Keep the same Project Manager Assigned to a Project from “Cradle to Grave”: This approach ensures institutional knowledge and consistency from the project development through construction completion and closeout. Other key steps in the process include:

- ✓ *Coordinate project advertisement*
- ✓ *Provide documents and plans to bidders*
- ✓ *Keep track of all of those who have purchased or shown interest in the project*
- ✓ *Send out any and all addenda/correspondence as necessary.*
- ✓ *Provide pre-bid meeting services*
- ✓ *Coordinate the bid opening with the client (date, time and place)*
- ✓ *Create a staff report and resolution awarding the project to the lowest responsive/responsible bidder*
- ✓ *Coordinate with contractor and consultants to sign contracts*
- ✓ *Coordinate with client to prepare fully executed contracts*
- ✓ *Submit a Notice to Proceed to the Contractor*

PROJECT CONTROLS (QA/QC)

Our staff utilizes proven management systems to closely track work quality, quantity, schedule, cost and budget for all projects as assigned by the City. Delivering projects under aggressive schedules requires careful management, administration, and oversight of project development teams from inception to completion. Our approach and detailed oversight produce projects that are typically within schedule and budget. Our staff works closely with the City and the project stakeholders to navigate issues that arise. Based on our experience, we will focus our efforts in the following areas:

Project Documentation – The Project Manager will oversee the construction manager/inspector, Geotechnical Firm, and ROW Firm on each project to assure adherence to established standards for project record keeping. Project and budget tracking are completed on excel spreadsheets developed by CAV Consulting.

Customer Service – Our staff are well versed and have much experience in the communication required when working in a municipal environment. Projects will impact residents, businesses, schools, and other agencies. We work with the City to identify all affected parties and then coordinate with them in a respectful and understanding manner during the life of the project. Our staff will coordinate with any public relations consultants at the City or on contract to ensure strong and accurate communications.

Services Proposed

As Project Managers, we will provide overall planning, coordination and control of a project from inception to completion. For each assigned project, we will acquire resources and coordinate the efforts of team members and third-party contractors or consultants in order to deliver the project according to established deadlines and within budget. CAV Consulting will also define the project's objectives and oversee quality control throughout the project life cycle. The project manager will act as an extension

of the City's staff and be available to perform project management duties throughout the entire duration of the projects assigned.

As Project Manager for the City, we will perform the following tasks:

- ✓ *Successfully manage more than one project at a time*
- ✓ *Define project scope, goals and deliverables that support the City's goals in collaboration with senior management and stakeholders*
- ✓ *Determine and assess need for staff and/or consultants and secure appropriate proposals and contracts*
- ✓ *Effectively communicate project expectations to team members and stakeholders*
- ✓ *Use project management checklists to identify project requirements and track completion of milestones*
- ✓ *Prepare and update project schedules from design through construction*
- ✓ *Track and monitor project milestones and deliverables*
- ✓ *Management project budget and minimize exposure to excessive risk in a project*
- ✓ *Identify permitting and environmental requirements*
- ✓ *Identify the elements of project design and construction likely to give rise to disputes, then proactively resolve and create contingency plans*
- ✓ *Conduct progress meetings*
- ✓ *Coordinate with other agencies and utilities*
- ✓ *Participate in the preparation of cost estimates and construction specifications*
- ✓ *Assure quality control*
- ✓ *Devise the project work plans and revisions as required*
- ✓ *Design submittal review*
- ✓ *Constructability review*
- ✓ *Participate in bidding phase*
- ✓ *Periodically inspect the project site and assist and provide technical guidance to inspectors in studying field problems and incorporation design revisions as necessary*
- ✓ *Maintain and control project documents*
- ✓ *Review design and construction contract amendments and change orders*
- ✓ *Prepare and present project reports on a regular basis*
- ✓ *Draft Staff reports for City Council*
- ✓ *Coach, mentor, and direct team members and contractors by influencing them to take positive action and accountability for their assigned work*
- ✓ *Build, develop, and grow business relationships vital to the success of the project*
- ✓ *Provide proper documentation to close projects in a timely manner*
- ✓ *Provide proper documentation to close projects in a timely manner*
- ✓ *Other project management duties as necessary to support City projects*

The following is the Resource Allocation Matrix:

Title	Average Hours/week	Maximum Hours/Week	Maximum Hours/Year
Senior Project Manager	20	30	960
Assistant Engineer	20	40	2080
Management Analyst	20	30	960

The hours shown above are estimated proposed available per position. The complexity and circumstances of each assigned project will determine the hours required. To minimize costs to the City, the Management Analyst and Assistant Engineer will support the Senior Project Manager on reports, investigations, background checks, and document review and preparations.

The following are brief descriptions of the Company’s staff recent experience in similar work including contact references:

CITY OF MORENO VALLEY – ON-CALL PROJECT MANAGEMENT SERVICES



Melissa Walker, PE
Public Works Director/City Engineer
14177 Frederick Street
Moreno Valley, CA 92552-0805
(951) 413-3116

CAV Consulting Staff is currently under contract with the City of Moreno Valley providing On-Call Project Management Services. Projects completed and on-going include the following:

- Citywide Street Rehabilitation Project – Locals (annual)
- Citywide Street Rehabilitation Project – Arterials and Collectors (annual)
- Heacock Street Pedestrian and Bicycle Facility Enhancements
- Moreno Beach Drive/SR60 Interchange Improvements Phase 2
- Kitching Street Storm Drain Improvements
- Juan Bautista de Anza Multi-Use Trail (ATP4)
- Citywide Pavement Rehabilitation Arterials and Collectors Phase 1– 10 year (Stimulus)
- Citywide Pavement Rehabilitation Arterials and Collectors Phase 2 – 10 year (Stimulus)
- Bicycle Pump Track Project
- Interim Principal Engineer Services (Capital Projects Division Head)
- Plan Checking Services for Public Works Land Development

“Chris has been a mentor to me for many years. His extensive experience, work ethics, and collaborative and professional approach encourages staff to think outside of the box and identify creative new approaches to solving complex issues.”

Prem Kumar, PE
Former City Engineer, City of Manhattan Beach
Former Assistant City Engineer, City of Moreno Valley

City of Victorville –Project Management – City Street Light Assessment Inventory and Conversion Assessment



Brian Gengler, PE
Former City Engineer
14343 Civic Drive Victorville
CA, 92392-2399
Cell (760) 963-4582

CAV Consulting provided Project Management and Special Assignment Services to complete field and map analysis to verify the existing street light inventory. CAV then completed a cost savings analysis to purchase the Citywide Streetlight System, assume the maintenance and operation of the system, and the energy saving of converting the streetlights from High Pressure Sodium Vapor (HPSV) to Light Emitting Diodes (LED).

Attachment: Agreement with CAV Consulting (6330 : AUTHORIZATION TO AWARD AGREEMENTS FOR PROFESSIONAL CONSULTING SENIOR



City of Indian Wells –Project Management, Engineering, Plan Checking and Building Services



Ken A. Seumalo, PE
 Public Works Director/City Engineer
 44-950 Eldorado Drive
 Indian Wells, California 92210-7497
 Direct (760) 776-0237

CAV Consulting Staff experience includes Project Management and Engineering Support Services on projects that were in the City’s Capital Improvement Program (CIP). These projects included:

- ✓ Camino Del Rey Overlay Project
- ✓ Eldorado Drop Structure Improvements
- ✓ RFP Process for On-Call Design Services

“Chris brings a wealth of experience and professionalism to every project. As a former Public Works Director/City Engineer, he understands the importance of meeting the needs of the community to build a quality project that is on schedule and under budget”

Christopher J. Freeland
 City Manager

The following are clients that are familiar with our success in the delivery of services and projects. We encourage you to contact them.

<p>City of Moreno Valley</p> <ul style="list-style-type: none"> ✓ Interim Principal Engineer Services ✓ Project Management ✓ Plan Check Services 	<p>Harold Zamora, PE <i>Engineering Division Manager/Assistant City Engineer</i> 14177 Frederick Street Moreno Valley, CA 92552 (951) 413-3106 Haroldz@moval.org</p>
<p>City of Indian Wells</p> <ul style="list-style-type: none"> ✓ Plan Check Services 	<p>Ken A. Seumalo, PE <i>Public Works Director/City Engineer</i> 44-950 Eldorado Drive Indian Wells, CA 92210-7497 (760) 776-0237 ksemalo@indianwells.com</p>
<p>City of Victorville</p> <ul style="list-style-type: none"> ✓ Project Management/Special Services 	<p>Brian Gengler, PE <i>City Engineer</i> 14343 Civic Drive Victorville, CA 92392-2399 (760) 955-5156 bgengler@victorvilleca.gov</p>

CAV Consulting’s goal is to deliver Public Works Capital projects within schedule and budget. During the process, we will provide all completed documents, including but not limited to spreadsheets, invoices, contracts, change orders, meeting minutes, correspondence, and schedules for each project in the City’s “P” Drive to ensure all pertinent records are kept with the City.

Attachment: Agreement with CAV Consulting (6330 : AUTHORIZATION TO AWARD AGREEMENTS FOR PROFESSIONAL CONSULTING SENIOR



SECTION 3: Proposed Staff/Team

CAV Consulting is committed to providing the expertise and resources required to support our clients with professional services to successfully meet or exceed their goals. We provide municipal services supporting Public Works, City Engineering, Capital Projects, Land Development, and Administration. Our team consists of professionals with years of service in the public sector. We work well with staff in all City Departments, outside agencies, the development community, and the public to achieve your organization's goals and successfully navigate and overcome project challenges. By incorporating a "Customer Care" philosophy, we have a successful track record of the delivery of services and projects on time and within budget.

The majority of CAV Consulting Staff experience has been in the public sector as City Officials and City Staff. Since we have all left public service, we have continued to provide services exclusively to Public Sector Clients. Below are the cities and Counties we have worked in either as staff or as consultants:

Chino Hills	Beaumont	Grand Terrace
La Quinta	Palm Springs	Laguna Niguel
Pomona	Indian Wells	Victorville
Moreno Valley	Rancho Mirage	Bell
Wildomar	West Covina	Riverside County
Eastvale	San Marino	San Bernardino County



We propose a highly qualified staff led by an experienced Senior Project Manager to deliver projects and services to meet or exceed the City's expectations. **Chris A. Vogt, PE** is the designated Principal Engineer and **Senior Project Manager** that will administer these services and will be the key contact to the City on a day-to-day basis. **Michelle Gonzalez, Assistant Engineer** is designated as the Assistant Engineer that will provide support to the Senior Project Manager including, but not limited to, tracking projects and budgets, drafting staff reports for review, coordination of meetings, taking and drafting meeting minutes, drafting Contract Change Orders and Amendments, and attend meetings as needed. **Gail Smerkol, Management Analyst** will provide administrative support to the Project Team and the City Division(s). This includes but is not limited to, coordinating invoices with City personnel, drafting, reviewing, and coordinating contracts, both Construction and Consultants, downloading all required documents to the different project folders in the City's Capital Projects Drive, drafting amendments and Council Staff Reports, Filing the Projects Notice of Completion, coordinating meetings, and assisting City Staff on City procedures.

All of the Key Personnel proposed will be available to the extent proposed for the duration of the project acknowledging that no person designated as "key" to the project shall be removed or replaced without the prior written concurrence of the City. The following are brief descriptions of the proposed professionals:

PROJECT MANAGEMENT

Chris A. Vogt, PE | Principal-in-Charge | Senior Project Manager

B.S. Civil Engineering, University of Pittsburgh. CA Registered Professional Engineer #44250

Chris has over 40 years of successful management, planning, implementing, and administering public works projects and programs. He brings a solid history of successful management with over 24 years as a Public Works Director/City Engineer for a number of Cities in Los Angeles, San Bernardino, and Riverside Counties. He brings an exemplary work ethic focusing on continuous process improvements while maintaining the ability to effectively navigate politically sensitive environments. Supporting cities in Southern California, Chris has a wealth of knowledge in budget preparation; infrastructure maintenance; professional and construction contract negotiations; organizational development; project management; water, sewer and electrical utility operations and construction; engineering design; staff development; training and mentoring; complex engineering studies such as Development Impact Fees and Assessment Engineering; and conducting public informational/collaborative meetings. Chris is a professional who brings solutions to our clients. He is flexible and his communication style fosters a teamwork atmosphere.

Attachment: Agreement with CAV Consulting (6330 : AUTHORIZATION TO AWARD AGREEMENTS FOR PROFESSIONAL CONSULTING SENIOR



Michelle Gonzalez | Assistant Engineer

Michelle is a recent graduate with a Bachelor of Science degree in Civil Engineering. She is Proficient in Excel, Word, and PowerPoint. She also has training and experience in AutoCAD and Civil 3D. Michelle is a self-motivated, dependable professional that excels in time management and problem solving.

She interned in the City of Chico's Public Works Department where she worked on submittals and permitting for the City and assisted the Engineering Staff with drafting standards and "in- house" designs on AutoCAD. Technical projects that Michell has worked on include designing a water treatment plant for Panajachel, Guatemala, assisting on a Sustainable Engineering project design utilizing Solar Energy, created a topographic map of a bike path with rest station, and created house plans using Civil 3D. She is an excellent communicator with a calm, approachable style. She is bi- lingual which is an added bonus in communicating with the public.

Gail Smerkol | Management Analyst

Gail's career encompasses more than fifteen (15) years of experience in financial data, customer service, and quality assurance. Five (5) of those years were with the City of Moreno Valley's Public Works Department both as a Consultant Management Analyst and as a full time City employee as a Management Assistant. Her background and education have resulted in the ability to analyze and improve operations by fostering collaboration in the workplace and refined written and oral communication skills for success in a management analyst role. She is proficient in Excel, Word, PowerPoint, and Adobe Acrobat Pro. She has training and experience using New World ERP, Accela Civic Platform (ACP), MinuteTraq, Geographic information system (GIS), and PlanetBids. Gail is goal-oriented and has excellent time management and problem-solving skills.

Projects that Gail has worked on include providing support with the Capital Improvement Plan (CIP) to collect and verify project information; participating in the verification of the budget and Life-to-Date expenditures utilizing Financial Management reports. Participated in analyses of City resource needs and allocation strategies to compile a 2-year Budget Proposal. Drafted multiple Standard Operating Procedures to provide step-by-step instructions to carry out routine operations (Department of Relations Industrial (DIR) Registration, PlanetBids Management, Encroachment Permits, Off-site record storage, ArcMap for Creating NPDES Maps, CFD Annexation Process, COA Process & Explanations, NPDES Mail Ballot Process, Street Light Outage Reporting, Street Light Authorization, Tax Bill Explanation, and Water Usage Data Entry).

The proposed team's resumes are as follows:



EDUCATION

Bachelor of Science, Civil Engineering
University of Pittsburgh
Pittsburgh, PA

REGISTRATIONS CERTIFICATIONS

CA Registered Civil Engineer | 44250

PROFESSIONAL AFFILIATIONS

APWA - American Public Works
Association, Southern California Chapter
President 2012

APWA - American Public Works
Association, Coachella Valley Branch of
Southern CA,
President & Creator, 2000 – 2001

APWA - American Public Works
Association, Inland Empire Branch of
Southern CA,
Board of Directors, 1992 – 1997

City/County Engineers Association
Inland Empire President, 1996

Chris A. Vogt, PE

Senior Project Manager

Chris has over 40 years of successful management, planning, implementing, and administering public works projects and programs. He brings a solid history of successful management with over 24 years as a Public Works Director/City Engineer for a number of Cities in Los Angeles, San Bernardino, and Riverside Counties. He brings an exemplary work ethic focusing on continuous process improvements while maintaining the ability to effectively navigate politically sensitive environments.

He has managed an operational budget of over \$39 million and a comprehensive Capital Improvement Program in excess of \$1.6 billion. Supporting cities in Southern California, Chris has a wealth of knowledge in budget preparation; infrastructure maintenance; professional and construction contract negotiations; organizational development; project management; water, sewer and electrical utility operations and construction; engineering design; staff development; training and mentoring; complex engineering studies such as Development Impact Fees and assessment engineering; and public informational and collaborative meetings.

Chris is a professional who brings solutions to our clients. He is flexible and his communication style fosters a teamwork atmosphere in resolving challenges. He is committed to serving the needs of the client through strong leadership and a collaborative approach.

Specific Experience

President | CEO | Public Works Director | City Engineer | Senior Project Manager

2020 - Present
CAV Consulting

In addition to developing and administering CAV Consulting, Chris provides project management, planning, developing, implementing, plan checking, and administering public works projects and programs for clients throughout Southern California. His projects include: Interim Principal Engineer/Division Manager for a City's Capital Projects Division; oversight/direction of Project Managers, developing and implementing capital improvement programs and development impact fees; staff training, mentoring and management; direction and supervision of professional and technical staff; program management over consulting contracts (design and construction management professionals); completion of specialty projects; and coordination of issues with public, the Development Community, Business Owners, and other Public Agencies.

Executive Vice President | Public Works Director | City Engineer | Senior Project Manager

2019 - 2020
Annealta Group

Chris provided project management, planning, developing, implementing, and administering public works projects and programs for clients throughout Southern California. His projects included: developing and implementing capital improvement programs and development impact fees; staff training, mentoring and management; direction and supervision of professional, technical and maintenance staff; program management over consulting contracts (design and construction management professionals); completion of specialty projects; and coordination of issues with public utilities.

Inland Empire/Coachella Valley Regional Manager | Public Works Director | City Engineer | Project Manager

2012 – 2019
Interwest Consulting Group

Chris developed and managed the Inland Empire/Coachella Valley Regional office. His duties included: interim Public Works Director and City Engineer assignments, project management, planning, developing, implementing, and administering public works projects and programs for clients throughout Southern California. His projects included: developing and implementing capital improvement programs and development impact fees; staff recruitment, hiring, training, mentoring and management; direction and supervision of professional, technical and maintenance staff; program management over con



Director of Public Works | City Engineer

2006 – 2011 City of Moreno Valley

Managed a Public Works Department of 145 professional, technical, maintenance, and clerical staff with an operational budget of \$39 million and Capital Improvement budget of \$180M (comprehensive \$1.6B). Public Works included seven divisions: Administration, Engineering, Land Development, Traffic, Capital Improvement Projects, Maintenance (solid waste, street, storm drainage, graffiti, and fleet), Special Districts, and the Moreno Valley Electric Utility.

Director of Public Works | City Engineer

2001 – 2006 City of Pomona

Supervised the Public Works Department of 97 professionals, which included Administration, Engineering, Development, Traffic, Capital Improvement Projects, Streets, Stormwater, Graffiti Abatement, Facilities Maintenance, Building and Safety, and City Communications.

Select Accomplishments:

- *Developed a comprehensive Capital Improvement Program*
- *Developed a bond issue with Gas Tax proceeds to complete \$10 million worth of street rehabilitations and improvements*
- *Completed \$2 million White Avenue beautification project fronting L.A. County Fairgrounds*
- *Established and implemented the City's Graffiti Abatement Program that improved removal time to 24 hours*

Director of Public Works | City Engineer

1996 – 2001 City of La Quinta

Managed the Public Works Department of 20 professional, technical, and clerical staff. This included Administration, Engineering, Development, Traffic, Capital Improvements and Street Maintenance.

Select Accomplishments:

- *Coordinated the development and implementation of La Quinta's first Development Impact Fees*
- *Updated the City's \$800K/year Lighting and Landscape Assessments to conform to Proposition 218*
- *Completed a \$500K community pool and locker room/office facility project within schedule and budget utilizing the design/build process*
- *Completed a \$20 million assessment issue and coordinated the construction associated with the assessment for public sewers, street improvements, and a downtown beautification project*

Director of Public Works | City Engineer

1991 – 1996 City of Chino Hills

Held multiple positions while serving the City of Chino Hills. Was appointed as the City's first Director of Public Works/City Engineer when the city incorporated in December 1991. Established and directed the Public Works Department of 55 employees under six divisions. These divisions included Administration, Engineering Design and Development, Traffic and Roads, Water, Sewer, Drainage, Utility Operations, and Facilities/Vehicle Maintenance and Operations, and the Parks and Landscape Maintenance Division

Select Accomplishments:

- *Completed the \$10 million extension of the ultimate improvements to Chino Hills Parkway*
- *Developed the first Public Works Department for the City of Chino Hills after Incorporation*
- *Supervised a \$13M/year Water Utility operational budget for the City*
- *Developed the first Pavement Management System for Chino Hills*
- *Developed and Streamlined the Final Map and Developer Entitlement process*



EDUCATION

Bachelor of Science, Civil Engineering
California State University
Chico

REGISTRATIONS CERTIFICATIONS

Testing for Engineer-in-Training (EIT)
Certificate in October 2023

PROFESSIONAL AFFILIATIONS

American Society of Civil Engineers (ASCE)

Latinos In Technical Careers (LTC)

Riverside City Council Student Board
Member (2012-2013)

Michelle Gonzalez

Assistant Engineer

Michelle is a recent driven graduate Civil Engineer, eager to learn and succeed. She is Proficient in Excel, Word, and PowerPoint. She has training and experience in AutoCAD and Civil 3D. Michelle is a self-motivated, dependable professional that excels in time management and problem solving. Due to the Covid pandemic causing the economy “shut-down”, Engineering jobs and projects were pretty much non-existent when Michelle graduated. She started her own “Math-Tutoring” business that has since grown to 25 clients ranging from elementary school to college students.

Michelle interned in the City of Chico’s Public Works Department where she worked on submittals and permitting for the City and assisted the Engineering Staff with drafting standards and “in-house” designs on AutoCAD.

Technical projects that Michell has worked on include designing a water treatment plant for Panajachel, Guatemala, assisting on a Sustainable Engineering project design utilizing Solar Energy, created a topographic map of a bike path with rest station, and created house plans using Civil 3D. She is an excellent communicator with a calm, approachable style. She is bi-lingual which is an added bonus in communicating with the public.

Specific Experience

Math Tutor

2021 - Present

Self Employed – Riverside, CA

Comprehensive math tutoring services for multiple students ranging from elementary to college level. Managed clientele, scheduling, and billing independently. Conducted initial assessments to evaluate student’s strengths, weaknesses, and learning styles. Created individualized lesson plans for each student. Successfully improved students grades and test scores.

Engineering Intern

2019 - 2020

Northstar, Inc – City of Chico

Aided in a variety of multi-disciplinary projects specializing in architecture, civil engineering, surveying, planning and environmental services. Assisted the Engineering Staff with drafting on AutoCAD, worked on submittals and permitting for the City. Attended City Council meetings for future/current projects. Completed field work such as surveying and percolation testing. Determined cost estimates for projects.

Undergraduate Researcher

2019 – 2019

California State University, Chico – Engineering Department

Aided a professor in a research project in the field of environmental engineering. The goal of the project was to achieve resource recovery from agriculture waste to provide safe water reuse and improve water quality by reducing pollution in Costa Rica. Outlined and wrote the goal and scope of the project. Determine sustainability by using SimaPro to determine life cycle assessment (LCA) and illustrated graphs to demonstrate the carbon footprint.



EDUCATION

Master of Science in Management and
Systems, 2020
New York University
New York, NY

Bachelor of Science in Organizational
Management, 2016
St. Joseph's University
Long Island, NY

Gail Smerkol

Management Analyst

Gail's career encompasses more than fifteen years of experience in financial data, customer service, and quality assurance. Background and education have resulted in the ability to analyze and improve operations by fostering collaboration in the workplace — refined written and oral communication for success in a management analyst role. She is proficient in Excel, Word, PowerPoint, and Adobe Acrobat Pro. She has training and experience using New World ERP, Accela Civic Platform (ACP), MinuteTraq, Geographic information system (GIS), and PlanetBids. Gail is goal-oriented and has excellent time management and problem-solving skills.

Projects that Gail has worked on include providing support with the Capital Improvement Plan (CIP) to collect and verify project information; participating in the verification of the budget and Life-to-Date expenditures utilizing Financial Management reports. Participated in analyses of City resource needs and allocation strategies to compile a 2-year Budget Proposal. Drafted multiple Standard Operating Procedures to provide step-by-step instructions to carry out routine operations (Department of Relations Industrial (DIR) Registration, PlanetBids Management, Encroachment Permits, Off-site record storage, ArcMap for Creating NPDES Maps, CFD Annexation Process, COA Process & Explanations, NPDES Mail Ballot Process, Street Light Outage Reporting, Street Light Authorization, Tax Bill Explanation, and Water Usage Data Entry).

Specific Experience

Management Analyst

2022 - Present

CAV Consulting – City of Moreno Valley, CA

Provide Management Analyst Support Services to the City's Capital Improvement Project Division and other City Departments and Divisions as assigned. Train new Moreno Valley Staff Members in Analyst duties including Contracts, Project Manager Support, recruitments, invoices, contract compliance, records keeping, and other duties as assigned by the City's Engineering Services Manager.

Management Assistant

2018 - 2022

City of Moreno Valley, CA – Public Works Department

Processed purchase requisitions, contracts, amendments, a variety of permits, and insurance certificate composed, revised, and generated reports, correspondence, memoranda's, consultant on-call on project-specific agreements, contract specification, public notices, drafted agreements for legal advisement review of contracts and legal documents by the City Attorney's office. Provide support in preparing bid documents, the bidding process, staff reports, contract change orders, and paying invoice. Processed, maintained, researched, and gathered support documentation on all Public Records Request liability claims, incident reports, and customer relationship management cases (CRMs).

Construction Administrator

2015 – 2016

T.F. Andrew – New Construction Division – New Rochelle, NY

Documented the progress of various construction projects, created customer billing invoices using Excel AIA spreadsheets, and route contracts. Achieved less than 1% job disturbance on projects while administering the order and delivery of material samples. Spearheaded travel arrangements and coordinating trade shows without a single adverse incident. Performed clerical work including answering telephone calls, providing customer service, and managing records.

Payment Processor/Credit Underwriter

2007 – 2014

Citi – The Lakes, NV

Improved department workflow by cross-training five operators in daily consolidations and payments processed. Performed high-volume data entry, nightly payment consolidations, and provided courteous customer service. Boosted team performance by recommending and creating a customer service training manual for telephone calls. Properly used confidential data to perform credit and financial analysis to identify and manage risk.

SECTION 4: Required Statements

CAV Consulting (Consultant) will abide by the following statements as required under Moreno Valley's RFP #2023-020 posted on August 28, 2023:

- This RFP shall be incorporated in its entirety as a part of the CAV Consulting's Proposal (Proposal).
- This RFP and the Proposal will jointly become part of the Agreement for Professional Consultant Services for this project when said Agreement is fully executed by the Consultant and the City Manager of Moreno Valley.
- The Consultant's Services to be provided, and fees therefore, will be in accordance with the City's RFP except as otherwise specified in the Consultant's Proposal under the heading "ADDITIONS OR EXCEPTIONS TO THE CITY'S REQUEST FOR PROPOSAL."
- A single and separate section with the heading "ADDITIONS OR EXCEPTIONS TO THE CITY'S REQUEST FOR PROPOSAL" (if needed) containing a complete and detailed description of all of the exceptions to the provisions and conditions of this Request for Proposal upon which the Consultant's Proposal is contingent and which shall take precedent over this RFP. **(Not needed, Consultant has no "Additions or Exceptions).**
- A statement of qualifications applicable to this project including the names, qualifications and proposed duties of the Consultant's Staff to be assigned to this project; a listing of recent similar projects completed including the names, titles, addresses and telephone numbers of the appropriate persons whom the City could contact. If one or more of the Consultant's staff should become unavailable, the Consultant may substitute other staff of at least equal competence only after prior written approval by the City. **(This has been included within the proposal)**
- A resource allocation matrix must be submitted with the Proposal. The resource allocation matrix must list detailed tasks in rows and the appropriate individual (Job Title Only) as well as the number of hours that these individuals will be working on each task listed, will be included in adjacent columns. The resource allocation matrix and the project design schedule are required of both the primary consultant, as well as any sub-consultant. In addition, the applicable construction support services consultant must list the type and number or hours of geotechnical tests being proposed, as well as the type and number of hours of inspection or survey work within the Proposal. Failure to do so will result in the Consultant's Proposal being deemed incomplete and it will not receive further consideration. The construction support services Consultant is not required to provide a Project Schedule with milestones.
- There are no sub-consultants proposed for these services. If a sub-consultant is required on a particular assigned project, the Consultant shall provide the sub-consultant's (include relief personnel) qualifications applicable to this project including the names, qualifications and proposed duties of the sub-consultant's staff to be assigned to this project; a listing of recent similar projects completed including the names, titles, addresses, and telephone numbers of the appropriate persons whom the City could contact.
- The Consultant acknowledges and understands that the Consultant will not be allowed to change the sub-consultant without written permission from the City.
- All charges for Consultant (construction) services is a "Not-to-Exceed Fee" which must include conservatively estimated reimbursable expenses, as submitted with and made a part of said Consultant's Proposal.
- The Consultant will document and provide the results of the work to the satisfaction of the City. This may include preparation of field and final reports, or similar evidence of attainment of the Agreement objectives.
- The Consultant will immediately document and notify the City of any defects or hazardous conditions observed in the vicinity of the project site prior, during, or after the construction work.
- A copy of the Consultant's hourly rate schedule has been submitted as a separate document, as required by the RFP, is part of the Consultant's Proposal for use in invoicing for progress payments and for extra work incurred that is not part of this RFP. An estimated itemized cost breakdown for the work described shall be submitted in a separate file, entitled Cost file, as part of the Consultant's Proposal submittal. All extra work will require prior approval from the City.
- The Consultant will not discriminate against any employee or applicant for employment because of race, color, religion, sex, or national origin.
- All federal laws and regulations shall be adhered to notwithstanding any state or local laws and regulations. In a case of conflict between federal, state or local laws or regulations, the strictest shall be adhered to.
- The Consultant shall allow all authorized federal, state, county, and City officials access to place of work, books,

documents, papers, fiscal, payroll, materials, and other relevant contract records pertinent to this special project. All relevant records shall be retained for at least three years.

- The Consultant shall comply with the Davis-Bacon Fair Labor Standards Act (40 USC 276-a through a-7), and the implementation regulations issued pursuant thereto (29 CFR Section 1, 5), any amendments thereof and the California Labor Code. Pursuant to the said regulations, entitled “Federal Labor Standards Provisions,” Federal Prevailing Wage Decision” and State of California prevailing wage rates, respectively.
- The Consultant shall comply with the Copeland Anti-Kickback Act (18 USC 874) and the Implementation Regulation (29 CFR 3) issued pursuant thereto, and any amendments thereof.
- The Consultant offers and agrees to assign to the City all rights, title, and interest in and to all causes of action it may have under Section 4 of the Clayton Act (15 USC Sec. 15) or under the Cartwright Act (Chapter 2 [commencing with Section 16700] of Part 2 of Division 7 of the Business and Professions Code), arising from purchases of goods, services, or materials pursuant to the public works or the subcontract. This assignment shall be made and become effective at the time the City tenders final payment to the Consultant, without further acknowledgment by the parties.

SECTION 5: Required Forms

As required by RFP#2023-020, and Addendums #1 and 2, the following required forms have been included as part of this proposal:

1. Non-Collusion Affidavit Form
2. Exhibit 10-01, Consulting Proposal DBE
3. Exhibit 10-Q. Disclosure of Lobbying Activities. – CAV Consulting has never participated in any Lobbying activities.

The required forms are on the following pages:

NONCOLLUSION DECLARATION

(To be executed by Bidder and Submitted with Bid)

The undersigned declares:

I am the President/Owner of CAV Consulting, the party making the foregoing bid.

The bid is not made in the interest of, or on behalf of, any undisclosed person, partnership, company, association, organization, or corporation. The bid is genuine and not collusive or sham. The bidder has not directly or indirectly induced or solicited any other bidder to put in a false or sham bid. The bidder has not directly or indirectly colluded, conspired, connived, or agreed with any bidder or anyone else to put in a sham bid, or to refrain from bidding. The bidder has not in any manner, directly or indirectly, sought by agreement, communication, or conference with anyone to fix the bid price of the bidder or any other bidder, or to fix any overhead, profit, or cost element of the bid price, or of that of any other bidder. All statements contained in the bid are true. The bidder has not, directly or indirectly, submitted his or her bid price or any breakdown thereof, or the contents thereof, or divulged information or data relative thereto, to any corporation, partnership, company, association, organization, bid depository, or to any member or agent thereof, to effectuate a collusive or sham bid, and has not paid, and will not pay, any person or entity for such purpose.

Any person executing this declaration on behalf of a bidder that is a corporation, partnership, joint venture, limited liability company, limited liability partnership, or any other entity, hereby represents that he or she has full power to execute, and does execute, this declaration on behalf of the bidder.

I declare under penalty of perjury under the laws of the State of California that the foregoing is true and correct and that this declaration is executed on September 14, 2023, at Moreno Valley, California [state].

By: 
_____ (signature)

Printed Name: Chris A. Vogt, PE

Title: President/Owner

EXHIBIT 10-01 CONSULTANT PROPOSAL DBE COMMITMENT

1. Local Agency: City of Moreno Valley 2. Contract DBE Goal: To be Determined (TBD)
 3. Project Description: Professional Consultant Senior Engineer Services
 4. Project Location: Within City of Moreno Valley Limits
 5. Consultant's Name: CAV Consulting 6. Prime Certified DBE:

7. Description of Work, Service, or Materials Supplied	8. DBE Certification Number	9. DBE Contact Information	10. DBE %
Perform project management and implementation	TBD	TBD	TBD
The Consultant is to fill out Exhibit 10-02 prior to working on a federal or state funded project with specific DBE goal to meet.			
Local Agency to Complete this Section			
17. Local Agency Contract Number: _____ 18. Federal-Aid Project Number: _____ 19. Proposed Contract Execution Date: _____ 20. Consultant's Ranking after Evaluation: _____ Local Agency certifies that all DBE certifications are valid and information on this form is complete and accurate. 21. Local Agency Representative's Signature _____ 22. Date _____ 23. Local Agency Representative's Name _____ 24. Phone _____ 25. Local Agency Representative's Title _____	11. TOTAL CLAIMED DBE PARTICIPATION TBD IMPORTANT: Identify all DBE firms being claimed for credit, regardless of tier. Written confirmation of each listed DBE is required.  12. Preparer's Signature _____ 13. Date <u>September 14, 2023</u> 14. Preparer's Name <u>Chris A. Vogt, PE</u> 15. Phone <u>(951) 616-4925</u> 16. Preparer's Title <u>President/Owner</u>		

DISTRIBUTION: Original -- Included with consultant's proposal to local agency.

ADA Notice: For individuals with sensory disabilities, this document is available in alternate formats. For information call (916) 654-6410 or TDD (916) 654-3880 or write Records and Forms Management, 1120 N Street, MS-89, Sacramento, CA 95814.

Attachment: Agreement with CAV Consulting (6330 : AUTHORIZATION TO AWARD AGREEMENTS FOR PROFESSIONAL CONSULTING SENIOR

EXHIBIT 10-Q DISCLOSURE OF LOBBYING ACTIVITIES

COMPLETE THIS FORM TO DISCLOSE LOBBYING ACTIVITIES PURSUANT TO 31 U.S.C. 1352

1. Type of Federal Action: <input type="checkbox"/> a. contract <input type="checkbox"/> b. grant <input type="checkbox"/> c. cooperative agreement <input type="checkbox"/> d. loan <input type="checkbox"/> e. loan guarantee <input type="checkbox"/> f. loan insurance		2. Status of Federal Action: <input type="checkbox"/> a. bid/offer/application <input type="checkbox"/> b. initial award <input type="checkbox"/> c. post-award		3. Report Type: <input type="checkbox"/> a. initial <input type="checkbox"/> b. material change For Material Change Only: year _____ quarter _____ date of last report _____	
4. Name and Address of Reporting Entity <input type="checkbox"/> Prime <input type="checkbox"/> Subawardee Tier _____, if known Congressional District, if known _____			5. If Reporting Entity in No. 4 is Subawardee, Enter Name and Address of Prime: Congressional District, if known _____		
6. Federal Department/Agency: _____			7. Federal Program Name/Description: CFDA Number, if applicable _____		
8. Federal Action Number, if known: _____			9. Award Amount, if known: _____		
10. Name and Address of Lobby Entity (If individual, last name, first name, MI) _____ (attach Continuation Sheet(s) if necessary)			11. Individuals Performing Services (including address if different from No. 10) (last name, first name, MI) _____ (attach Continuation Sheet(s) if necessary)		
12. Amount of Payment (check all that apply) \$ _____ <input type="checkbox"/> actual <input type="checkbox"/> planned		14. Type of Payment (check all that apply) <input type="checkbox"/> a. retainer <input type="checkbox"/> b. one-time fee <input type="checkbox"/> c. commission <input type="checkbox"/> d. contingent fee <input type="checkbox"/> e. deferred <input type="checkbox"/> f. other, specify _____			
13. Form of Payment (check all that apply): <input checked="" type="checkbox"/> a. cash <input type="checkbox"/> b. in-kind; specify: nature _____ Value _____					
15. Brief Description of Services Performed or to be performed and Date(s) of Service, including officer(s), employee(s) or member(s) contacted, for Payment Indicated in Item 12: _____ (attach Continuation Sheet(s) if necessary)					
16. Continuation Sheet(s) attached: Yes <input type="checkbox"/> No <input type="checkbox"/>					
17. Information requested through this form is authorized by Title 31 U.S.C. Section 1352. This disclosure of lobbying reliance was placed by the tier above when his transaction was made or entered into. This disclosure is required pursuant to 31 U.S.C. 1352. This information will be reported to Congress semiannually and will be available for public inspection. Any person who fails to file the required disclosure shall be subject to a civil penalty of not less than \$10,000 and not more than \$100,000 for each such failure.					
Signature: <u>CAV</u> Print Name: <u>Chris A. Vogt</u> Title: <u>President/owner</u> Telephone No.: <u>(951) 616-4925</u> Date: <u>9/6/2023</u>			Authorized for Local Reproduction Standard Form - LLL		
Federal Use Only: <u>CAV Consulting has never funded or participated in lobbying activities.</u>					

Standard Form LLL Rev. 04-28-06

Distribution: Orig- Local Agency Project Files

Attachment: Agreement with CAV Consulting (6330 : AUTHORIZATION TO AWARD AGREEMENTS FOR PROFESSIONAL CONSULTING SENIOR

SECTION 6: Cost Proposal

The Cost Proposal is submitted separately as required in the RFP.

Attachment: Agreement with CAV Consulting (6330 : AUTHORIZATION TO AWARD AGREEMENTS FOR PROFESSIONAL CONSULTING SENIOR



EXHIBIT "C"CITY - SERVICES TO BE PROVIDED
TO CONSULTANT

1. Furnish the Consultant all in-house data which is pertinent to services to be performed by the Consultant and which is within the custody or control of the City, including, but not limited to, copies of record and off-record maps and other record and off-record property data, right-of-way maps and other right-of-way data, pending or proposed subject property land division and development application data, all newly developed and pertinent design and WORK specification data, and such other pertinent data which may become available to the City.
2. Provide timely review, processing, and reasonably expeditious approval of all submittals by the Consultant.
3. Provide timely City staff liaison with the Consultant when requested and when reasonably needed.

EXHIBIT "D"

TERMS OF PAYMENT

1. The Consultant's compensation shall not exceed \$ **TBD** .
2. The Consultant will obtain, and keep current during the term of this Agreement, the required City of Moreno Valley business license. Proof of a current City of Moreno Valley business license will be required prior to any payments by the City. Any invoice not paid because the proof of a current City of Moreno Valley business license has not been provided will not incur any fees, late charges, or other penalties. Complete instructions for obtaining a City of Moreno Valley business license are located at: <http://www.moval.org/biz-lic>.
3. The Consultant will electronically submit an invoice to the City along with documentation evidencing services completed to date as specified in the Request for Proposal. Progress payments will be made in accordance with the payment schedule outlined in the Request for Proposal, but in no case will progress payments be made to the Consultant more frequently than once per month. The progress payment is based on actual time and materials expended in furnishing authorized professional services during the preceding calendar month. At no time will the City pay for more services than have been satisfactorily completed and the City Engineer's determination of the amount due for any progress payment shall be final. The consultant will submit all original invoices to Accounts Payable staff at TechInfo-CapProj@moval.org. Accounts Payable questions can be directed to (951) 413-3130.
4. The Consultant agrees that City payments will be received via Automated Clearing House (ACH) Direct Deposit and that the required ACH Authorization form will be completed prior to any payments by the City. Any invoice not paid because the

completed ACH Authorization Form has not been provided will not incur any fees, late charges, or other penalties. The ACH Authorization Form is located at:

http://www.moval.org/city_hall/forms.shtml#bf

5. The minimum information required on all invoices is:
 - A. Vendor Name, Mailing Address, and Phone Number
 - B. Invoice Date
 - C. Vendor Invoice Number
 - D. City-provided Reference Number (e.g. WORK, Activity)
 - E. Detailed work hours by class title (e.g. Manager, Technician, or Specialist), services performed and rates, explicit portion of a contract amount, or detailed billing information that is sufficient to justify the invoice amount; single, lump amounts without detail are not acceptable.

6. The City shall pay the Consultant for all invoiced, authorized professional services within thirty (30) days of receipt of the invoice for same.



COST PROPOSAL

RFP # 2023 - 020

**Professional Consultant Senior Engineer
Services**

PREPARED FOR

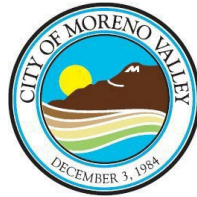

City of Moreno Valley – Purchasing Division

14177 Frederick Street

P.O. Box 88005

Moreno Valley, CA 92552

SUBMITTED BY

CAV CONSULTING

Chris A. Vogt, PE | President/Owner

17130 Van Buren Blvd., Ste 526

Riverside, CA 92504

direct 951.616.4925

cvogt@cavconsultinggroup.com

Attachment: Agreement with CAV Consulting (6330 : AUTHORIZATION TO AWARD AGREEMENTS FOR PROFESSIONAL CONSULTING SENIOR



FY 2023/24

CAV CONSULTING - HOURLY RATES FOR SERVICES

Hourly billing rates for the specific services proposed are as follows:

Classification	Rate
Principal.....	\$200
Public Works Director	185
City Engineer	180
Senior Project Manager	175
Project Manager	170
Traffic Engineer	165
Senior Construction Manager.....	165
Construction Manager	155
Management Analyst.....	121
Staff Analyst.....	118
Resident Engineer.....	165
Plan Check Engineer III	160
Plan Check Engineer II	155
Plan Check Engineer I.....	150
Senior Engineer	170
Associate Engineer	150
Assistant Engineer (EIT).....	134
Engineering Technician II	115
Engineering Technician I	110
Administrative Support II.....	70
Administrative Support I.....	65
Senior Public Works Inspector (or prevailing wage).....	150
Public Works Inspector IV	140
Public Works Inspector III.....	135
Public Works Inspector II.....	130
Public Works Inspector I.....	125
<u>Building and Safety Services</u>	
Building Official	160
Building Plans Examiner III.....	150
Building Plans Examiner II.....	145
Building Plans Examiner I.....	140
Sr. Building Inspector (or Prevailing Wage).....	150
Building Inspector II.....	140
Building Inspector I.....	130
Certified Permit Technician	80

Consultation in connection with litigation and court appearances will be quoted separately. Overtime will be billed at 1.5 times, and Sundays and holidays 2.0 times the standard rate. A sub consultant management fee of ten percent (10%) will be added to the direct cost of all sub consultant services to provide for the cost of administration, consultation and coordination. Valid thru FY 2023/2024; thereafter, the rates may be raised once per year to the value of change of the Consumer Price Index for the Riverside County.



CAV Consulting

Attachment: Agreement with CAV Consulting (6330 : AUTHORIZATION TO AWARD AGREEMENTS FOR PROFESSIONAL CONSULTING SENIOR

EXHIBIT "E"

INSURANCE REQUIREMENTS

Minimum Scope of Insurance

Coverage shall be at least as broad as:

1. The most current version of Insurance Services Office (ISO) Commercial General Liability Coverage Form CG 00 01, which shall include insurance for "bodily injury," "property damage" and "personal and advertising injury" with coverage for premises and operations, products and completed operations, and contractual liability.
2. The most current version of Insurance Service Office (ISO) Business Auto Coverage Form CA 00 01, which shall include coverage for all owned, hired, and non-owned automobiles or other licensed vehicles (Code 1- Any Auto).
3. Workers' Compensation insurance as required by the California Labor Code and Employer's Liability Insurance.
4. Professional Liability (Errors and Omissions) insurance appropriate to Consultant's profession.

Minimum Limits of Insurance

Consultant shall maintain limits of liability of not less than:

1. General Liability:
 - \$1,000,000 per occurrence for bodily injury and property damage
 - \$1,000,000 per occurrence for personal and advertising injury
 - \$2,000,000 aggregate for products and completed operations
 - \$2,000,000 general aggregate
2. Automobile Liability:
 - \$1,000,000 per accident for bodily injury and property damage
3. Employer's Liability:
 - \$1,000,000 each accident for bodily injury
 - \$1,000,000 disease each employee
 - \$1,000,000 disease policy limit

Attachment: Agreement with CAV Consulting (6330 : AUTHORIZATION TO AWARD AGREEMENTS FOR PROFESSIONAL CONSULTING SENIOR

4. Professional Liability (Errors and Omissions):

\$1,000,000 per claim/occurrence
\$2,000,000 policy aggregate

Umbrella or Excess Insurance

In the event Consultant purchases an Umbrella or Excess insurance policy(ies) to meet the "Minimum Limits of Insurance," this insurance policy(ies) shall "follow form" and afford no less coverage than the primary insurance policy(ies).

Deductibles and Self-Insured Retentions

Consultant shall be responsible for payment of any deductibles contained in any insurance policy(ies) required hereunder and Consultant shall also be responsible for payment of any self-insured retentions. Any deductibles or self-insured retentions must be declared to, and approved by, the City Manager or his/her designee. At the option of the City Manager or his/her designee, either (i) the insurer shall reduce or eliminate such deductibles or self-insured retentions as respects The City of Moreno Valley, the City of Moreno Valley Community Services District, the Moreno Valley Housing Authority, and each of their officers, officials, employees, agents and volunteers; or (ii) Consultant shall provide a financial guarantee, satisfactory to the City Manager or his/her designee, guaranteeing payment of losses and related investigations, claim administration and defense expenses. At no time shall City be responsible for the payment of any deductibles or self-insured retentions.

Other Insurance Provisions

The General Liability and Automobile Liability insurance policies are to contain, or be endorsed to contain, the following provisions:

1. The City of Moreno Valley, the City of Moreno Valley Community Services District, the Moreno Valley Housing Authority, and each of their officers, officials, employees, agents and volunteers are to be covered as additional insureds.
2. The coverage shall contain no special limitations on the scope of protection afforded to the City of Moreno Valley, the City of Moreno Valley Community Services District, the Moreno Valley Housing Authority, and each of their officers, officials, employees, agents and volunteers.
3. Consultant's insurance coverage shall be primary and no contribution shall be required of City.

The Workers' Compensation insurance policy is to contain, or be endorsed to contain, the following provision: Consultant and its insurer shall waive any right of subrogation against the City of Moreno Valley, the City of Moreno Valley Community Services District, the Moreno Valley Housing Authority, and each of their officers, officials, employees, agents and volunteers. If the Professional Liability (Errors and Omissions) insurance policy is written on a claims-made

form:

1. The retroactive date must be shown, and must be before the effective date of the Agreement or the commencement of work by Consultant.
2. Insurance must be maintained and evidence of insurance must be provided for at least 3 years after any expiration or termination of the Agreement or, in the alternative, the policy shall be endorsed to provide not less than a 3-year discovery period.
3. If coverage is canceled or non-renewed, and not replaced with another claims-made policy form with a retroactive date prior to the effective date of the Agreement or the commencement of work by Consultant, Consultant must purchase extended reporting coverage for a minimum of 3 years following the expiration or termination of the Agreement.
4. A copy of the claims reporting requirements must be submitted to City for review.
5. These requirements shall survive expiration or termination of the Agreement.

All policies of insurance required hereunder shall be endorsed to provide that the coverage shall not be cancelled, non-renewed, reduced in coverage or in limits except after 30 calendar day written notice by certified mail, return receipt requested, has been given to City. Upon issuance by the insurer, broker, or agent of a notice of cancellation, non-renewal, or reduction in coverage or in limits, Consultant shall furnish City with a new certificate and applicable endorsements for such policy(ies). In the event any policy is due to expire during the work to be performed for City, Consultant shall provide a new certificate, and applicable endorsements, evidencing renewal of such policy not less than 15 calendar days prior to the expiration date of the expiring policy.

Acceptability of Insurers

All policies of insurance required hereunder shall be placed with an insurance company(ies) admitted by the California Insurance Commissioner to do business in the State of California and rated not less than "A-VII" in Best's Insurance Rating Guide; or authorized by the City Manager or his/her designee.

Verification of Coverage

Consultant shall furnish City with all certificate(s) and **applicable endorsements** effecting coverage required hereunder. All certificates and **applicable endorsements** are to be received and approved by the City Manager or his/her designee prior to City's execution of the Agreement and before work commences.

**AGREEMENT FOR
PROFESSIONAL CONSULTANT SENIOR ENGINEER AND
RELATED ADMINISTRATIVE SERVICES FOR CAPITAL PROJECTS DIVISION**

This Agreement (hereinafter, this “Agreement”) is made and entered into this ____ day of _____ 2023 (“Effective Date”), by and between the City of Moreno Valley, a municipal corporation in the County of Riverside, State of California, hereinafter referred to as the “City,” and **HR Green Pacific, Inc.**, (California corporation, partnership, sole ownership), hereinafter referred to as “Consultant.”

RECITALS

WHEREAS, the City has determined it is in the public interest to proceed with the professional consultant senior engineer and administrative services hereinafter described as "WORK"; and

WHEREAS, the City has determined the WORK involves the performance of professional and technical services of a temporary nature as more specifically described in Exhibit "A" (City's Request for Proposal) and Exhibit "B" (Consultant's Proposal) hereto; and

WHEREAS, the City does not have available employees to perform the services for the WORK; and

WHEREAS, the City has requested the Consultant to perform such services for the WORK; and

WHEREAS, the Consultant is professionally qualified in California to perform the professional and technical services required for the WORK, and hereby represents that it desires to and is professionally and legally capable of performing the services called for by this Agreement;

THEREFORE, the City and the Consultant, for the consideration hereinafter described, mutually agree as follows:

Attachment: Agreement with HR Green Pacific (6330 : AUTHORIZATION TO AWARD AGREEMENTS FOR PROFESSIONAL CONSULTING

**AGREEMENT FOR PROFESSIONAL CONSULTANT
SENIOR ENGINEER AND ADMINISTRATIVE SERVICES**

DESCRIPTION OF WORK

1. The WORK is described as Professional Consultant Senior Engineer and Administrative Services.

SCOPE OF SERVICES

2. The Consultant's scope of service is described on Exhibit "B" attached hereto and incorporated herein by this reference. In the event of a conflict, the City's Request for Proposal shall take precedence over the Consultant's Proposal.

3. The City's responsibility is described on Exhibit "C" attached hereto and incorporated herein by this reference.

PAYMENT TERMS

4. The City agrees to pay the Consultant and the Consultant agrees to receive a "Not-to-Exceed" fee of \$ TBD in accordance with the payment terms provided on Exhibit "D" attached hereto and incorporated herein by this reference.

TIME FOR PERFORMANCE

5. The Consultant shall commence services upon receipt of written direction to proceed from the City.

6. The Consultant shall perform the work described on Exhibit "A" in accordance with the schedule set forth in Exhibit "B" attached hereto and incorporated by this reference.

7. This Agreement shall be effective from effective date and shall continue in full force and effect date through December 30, 2026, subject to any earlier termination in accordance with this Agreement. The services of Consultant shall be completed in a sequence assuring expeditious completion, but in any event, all such services shall be completed prior to expiration of this Agreement.

8. (a) The Consultant agrees that the personnel, including the principal WORK

**AGREEMENT FOR PROFESSIONAL CONSULTANT
SENIOR ENGINEER AND ADMINISTRATIVE SERVICES**

Manager, and all subconsultants assigned to the WORK by the Consultant, shall be subject to the prior approval of the City.

(b) No change in subconsultants or key personnel shall be made by the Consultant without written prior approval of the City.

SPECIAL PROVISIONS

9. It is understood and agreed that the Consultant is, and at all times shall be, an independent consultant and nothing contained herein shall be construed as making the Consultant or any individual whose compensation for services is paid by the Consultant, an agent or employee of the City, or authorizing the Consultant to create or assume any obligation or liability for or on behalf of the City.

10. The Consultant may also retain or subcontract for the services of other necessary consultants with the prior written approval of the City. Payment for such services shall be the responsibility of the Consultant. Any and all subconsultants employed by the Consultant shall be subject to the terms and conditions of this Agreement, except that the City shall have no obligation to pay any subconsultant for services rendered on the WORK.

11. The Consultant and the City agree to use reasonable care and diligence to perform their respective services under this Agreement.

12. The Consultant shall comply with applicable federal, state, and local laws in the performance of work under this Agreement.

13. To the extent required by controlling federal, state and local law, Consultant shall not employ discriminatory practices in the provision of services, employment of personnel, or in any other respect on the basis of race, religious creed, color, national origin, ancestry, physical disability, mental disability, medical condition, marital status, sex, age, sexual orientation, ethnicity, status as a disabled veteran or veteran of the Vietnam era. Subject to the foregoing

**AGREEMENT FOR PROFESSIONAL CONSULTANT
SENIOR ENGINEER AND ADMINISTRATIVE SERVICES**

and during the performance of this Agreement, Consultant agrees as follows:

(a) Consultant will comply with all applicable laws and regulations providing that no person shall, on the grounds of race, religious creed, color, national origin, ancestry, physical disability, mental disability, medical condition, marital status, sex, age, sexual orientation, ethnicity, status as a disabled veteran or veteran of the Vietnam era be excluded from participation in, be denied the benefits of, or be subject to discrimination under any program or activity made possible by or resulting from this Agreement.

(b) Consultant will not discriminate against any employee or applicant for employment because of race, religious creed, color, national origin, ancestry, physical disability, mental disability, medical condition, marital status, sex, age, sexual orientation, ethnicity, status as a disabled veteran or veteran of the Vietnam era. Consultant shall ensure that applicants are employed, and the employees are treated during employment, without regard to their race, religious creed, color, national origin, ancestry, physical disability, mental disability, medical condition, marital status, sex, age, sexual orientation, ethnicity, status as a disabled veteran or veteran of the Vietnam era. Such requirements shall apply to Consultant's employment practices including, but not be limited to, the following: employment, upgrading, demotion or transfer; recruitment or recruitment advertising; layoff or termination; rates of pay or other forms of compensation; and selection for training, including apprenticeship. Consultant agrees to post in conspicuous places, available to employees and applicants for employment, notices setting forth the provision of this nondiscrimination clause.

(c) Consultant will, in all solicitations or advertisements for employees placed by or on behalf of Consultant in pursuit hereof, state that all qualified applicants will receive consideration for employment without regard to race, religious creed, color, national origin, ancestry, physical disability, mental disability, medical condition, marital status, sex, age, sexual

**AGREEMENT FOR PROFESSIONAL CONSULTANT
SENIOR ENGINEER AND ADMINISTRATIVE SERVICES**

orientation, ethnicity, status as a disabled veteran or veteran of the Vietnam era.

(d) If Consultant should subcontract all or any portion of the services to be performed under this Agreement, Consultant shall cause each subconsultant to also comply with the requirements of this Section 13.

14. Indemnification.

a. Design Professional Services. To the fullest extent permitted by law, including but not limited to Civil Code Section 2782.8, in performing “design professional services” as defined in Section 2782.8, the Consultant agrees to indemnify, and hold the City, the Moreno Valley Community Services District (CSD), and the Moreno Valley Housing Authority (MVHA), their officers, and employees harmless from any and all liability, damages, or injuries to any person, including injury to the Consultant's employees and costs to the extent caused by negligent, reckless, or willful misconduct in the performance of the work, or are caused by the negligent acts of the Consultant, its officers, agents or employees, or its subconsultant(s) or any person acting for the Consultant or under its control or direction; provided, however, that this indemnification and hold harmless shall not include claims arising from the sole negligence, active negligence, or willful misconduct of the City, MVHA, and CSD, their officers, agents or employees; and does not apply to any passive negligence of City.

b. Non-Design Professional Services. For all non-design professional services, Consultant shall indemnify, defend, and save the City, the Moreno Valley Community Services District (CSD), and the Moreno Valley Housing Authority (MVHA), their officers, agents and employees harmless from any and all liability, claims, demands, damages, or injuries to any

**AGREEMENT FOR PROFESSIONAL CONSULTANT
SENIOR ENGINEER AND ADMINISTRATIVE SERVICES**

person, including injury to the Consultant's employees and all claims which arise from or are connected with the performance of or failure to perform the work or other obligations of the Consultant, or are caused or claim to be caused by the acts of the Consultant, its officers, agents or employees, or its subconsultant(s) or any person acting for the Consultant or under its control or direction; provided, however, that this indemnification and hold harmless shall not include claims arising from the sole negligence or willful misconduct of the City, MVHA, and CSD, their officers, agents or employees.

c. If Consultant should subcontract all or any portion of the services to be performed under this Agreement, Consultant shall require each subconsultant to indemnify, hold harmless and defend City, CSD, Housing Authority and each of their officers, officials, employees, agents and volunteers in accordance with the terms of the preceding paragraph.

d. CalPERS Indemnity. To the fullest extent permitted by law, in addition to obligations set forth in this section, in the event that any person providing services under this Agreement is determined by a court of competent jurisdiction or CalPERS to be eligible for enrollment in CalPERS as an employee of the City, to the fullest extent of the law, Consultant shall indemnify, defend, and hold harmless City for any costs and expenses incurred by City, including without limitation, payment that City is required as a result to make to CalPERS, whether in the form of employee and/or employer contributions, taxes, or any similar obligations, as well as for the payment of any penalties and interest.

15. CalPERS Participation. As set forth in this Agreement and in the Request for Qualifications, City has an obligation to treat all persons working for or under the direction of Consultant as an independent Consultant of City and agents and employees of Consultant, and not as agents or employees of City. Consultant and City acknowledge and agree that City participates in a defined benefit plan ("CalPERS"), and that it is possible that CalPERS may find

**AGREEMENT FOR PROFESSIONAL CONSULTANT
SENIOR ENGINEER AND ADMINISTRATIVE SERVICES**

that persons providing services pursuant to this Agreement are employees of City and should be registered with the CalPERS as employees of City.

16. CalPERS Retiree Disclosure. Consultant hereby expressly agrees to clearly and conspicuously disclose to City in writing any and all persons working for Consultant who are retirees under the California Public Employees' Retirement System (CalPERS) whom receives a monthly CalPERS retirement allowance, and whom are, subject to City approval, assigned by Consultant to provide services to City under the Agreement, prior to such person performing any services hereunder. Nothing herein shall be deemed or interpreted to limit a CalPERS retiree's obligations under applicable law, rules or regulations.

Joint Cooperation. In the event that CalPERS initiates an inquiry that includes examination of whether individuals providing services under this Agreement to City are City's employees, Consultant shall within five days and share all communications and documents from CalPERS that it may legally share. In the event that either Consultant or City files an appeal or court challenge, Consultant and City each agree to cooperate with each other in responding to the inquiry and any subsequent administrative appeal or court challenge of an adverse determination.

This section shall survive termination or expiration of this Agreement.

17. Insurance.

(a) Throughout the life of this Agreement, Consultant shall pay for and maintain in full force and effect all insurance as required in **Exhibit E** or as may be authorized in writing by the City Manager or his/her designee at any time and in his/her sole discretion.

(b) If at any time during the life of the Agreement or any extension, Consultant or any of its subconsultant fail to maintain any required insurance in full force and effect, all services and work under this Agreement shall be discontinued immediately, and all payments

**AGREEMENT FOR PROFESSIONAL CONSULTANT
SENIOR ENGINEER AND ADMINISTRATIVE SERVICES**

due or that become due to Consultant shall be withheld until notice is received by City that the required insurance has been restored to full force and effect and that the premiums therefore have been paid for a period satisfactory to City. Any failure to maintain the required insurance shall be sufficient cause for City to terminate this Agreement. No action taken by City pursuant to this section shall in any way relieve Consultant of its responsibilities under this Agreement. The phrase "fail to maintain any required insurance" shall include, without limitation, notification received by City that an insurer has commenced proceedings, or has had proceedings commenced against it, indicating that the insurer is insolvent.

(c) The fact that insurance is obtained by Consultant shall not be deemed to release or diminish the liability of Consultant, including, without limitation, liability under the indemnity provisions of this Agreement. The duty to indemnify City shall apply to all claims and liability regardless of whether any insurance policies are applicable. The policy limits do not act as a limitation upon the amount of indemnification to be provided by Consultant. Approval or purchase of any insurance contracts or policies shall in no way relieve from liability nor limit the liability of Consultant, its principals, officers, agents, employees, persons under the supervision of Consultant, vendors, suppliers, invitees, consultants, sub-consultants, subconsultants or anyone employed directly or indirectly by any of them.

(d) Upon request of City, Consultant shall immediately furnish City with a complete copy of any insurance policy required under this Agreement, including all endorsements, with said copy certified by the underwriter to be a true and correct copy of the original policy. This requirement shall survive expiration or termination of this Agreement.

(e) If Consultant should subcontract all or any portion of the services to be performed under this Agreement, Consultant shall require each subconsultant to provide insurance protection in favor of City and each of its officers, officials, employees, agents and

**AGREEMENT FOR PROFESSIONAL CONSULTANT
SENIOR ENGINEER AND ADMINISTRATIVE SERVICES**

volunteers in accordance with the terms of this section, except that any required certificates and applicable endorsements shall be on file with Consultant and City prior to the commencement of any services by the subconsultant.

18. The waiver by either party of a breach by the other of any provision of this Agreement shall not constitute a continuing waiver or a waiver of any subsequent breach of either the same or a different provision of this Agreement. No provisions of this Agreement may be waived unless in writing and signed by all parties to this Agreement. Waiver of any one provision herein shall not be deemed to be a waiver of any other provision herein.

19. Consultant and subconsultants shall pay prevailing wage rates when required by the Labor Laws of the State of California. Consultant and all of Consultant's subcontractors, if any, shall pay each employee engaged in all applicable trades or occupation not less than the prevailing hourly wage rate for work of a similar character in the locality in which the public work is performed, and not less than the general prevailing rate of per diem wages for holiday and overtime work. In accordance with the provisions of Section 1770 of the California Labor Code ("Labor Code"), the Director of Department of Industrial Relations of the State of California has determined the general prevailing rates of wages and employer payments for health and welfare, pension, vacation, travel time, and subsistence pay as provided for in Labor Code Section 1773.8, apprenticeship or other training programs authorized by Labor Code Section 3093 and similar purposes applicable to the work to be done. Said wages are available through the California Department of Industrial Relations' Internet website at <http://www.dir.ca.gov/dlsr/PWD/index.htm> and are on file at City Hall, as provided in Section 1773.2 of the Labor Code. Said rates shall be posted at the WORK site where work is to be performed, in accordance with Labor Code Section 1773.2. Consultant shall access a copy of the wage rate determination and shall make all subcontractors, if any, aware of the

**AGREEMENT FOR PROFESSIONAL CONSULTANT
SENIOR ENGINEER AND ADMINISTRATIVE SERVICES**

determination. As the wage determination for each craft reflects an expiration date, it shall be the Consultant's responsibility to ensure that the prevailing wage rates of concern are current and paid. Subject to the safe harbor provisions of Labor Code Section 1775, Consultant shall forfeit to the City an amount not to exceed two hundred dollars (\$200) for each calendar day or portion thereof, as set by the Labor Commissioner in accordance with the terms of Labor Code section 1775, for each laborer, workmen or mechanics employed that is paid less than the general prevailing rate of wages herein referred to and stipulated for any work done under the proposed contract, by him, or by any subcontractor under him, in violation of the provisions of the Labor Code, and in particular, Sections 1770 to 1781 inclusive. Consultant and any and all or its subcontractors shall forfeit to the City twenty-five dollars (\$25) for each worker employed in the performance of this Agreement for each calendar day during which the worker is required or permitted to work more than eight (8) hours in any one calendar day and forty (40) hours in any one calendar week in violation of the provisions of Section 1813 of the Labor Code. In the event the total cost of the WORK is thirty thousand dollars (\$30,000.00) or more, Consultant shall further comply with provisions set forth in Labor Code Section 1777.5 pertaining to employment of properly registered apprentices, including without limitation the obligation to (i) pay employed apprentices the prevailing rate of per diem wages for apprentices in the trade to which he or she is registered and shall be employed only at the work of craft or trade to which he or she is registered; (ii) employ apprentices in at least the ratio as set forth in said section; (iii) submit contract award information to an applicable apprenticeship program; and (iv) contribute to California Apprenticeship Council.

Consultant and all subcontractors hired to perform any work under the WORK shall keep accurate payroll records, including the name, address, social security number, work classification, straight time and overtime hours worked each day and week, and the actual per

**AGREEMENT FOR PROFESSIONAL CONSULTANT
SENIOR ENGINEER AND ADMINISTRATIVE SERVICES**

diem wages paid to each worker, in accordance with Section 1776 of the Labor Code. Payroll records shall be on forms provided by the Division of Labor Standards Enforcement (“DLSE”) or in a manner containing the same information as the forms provided by the DLSE. Failure to comply with the above may result in monetary penalties to the Consultant or affected subcontractor. Payroll records shall be verified by written declaration made under penalty of perjury, that the information contained in the records is true and correct. Consultant and any and all subcontractors shall make a certified copy of all payroll records available for inspection by DLSE, the City or any member of the public and otherwise provide certified copies of such records to any of the foregoing within ten (10) days of Consultant’s and subcontractor’s receipt of written request therefor. Failure to comply with the above may result in monetary penalties, in accordance with Labor Code Section 1776(d) and (h).

Notwithstanding anything else to the contrary, Consultant hereby acknowledges that all contractors and subcontractors must be registered with the Department of Industrial Relations (“Department”) pursuant to Labor Code Section 1725.5 in order to be qualified to bid on, be listed in a bid proposal, subject to the requirements of Section 4104 of the Public Contract Code, or engage in the performance of any public work contract, including this Agreement, that is subject to the payment of prevailing wages. The WORK is subject to compliance monitoring and enforcement by the Department of Industrial Relations. In accordance with Section 3700 of the Labor Code, Consultant must secure payment of compensation to all Consultant’s employees. Consultant represents and warrants that Consultant is registered with the Department in the manner prescribed by the Department and has paid the requisite application fee, as required by Labor Code Section 1725.5. Moreover, prior to Consultant entering into any contracts with any subcontractor, Consultant shall obtain proof that all such subcontractors have also registered with the Department in accordance with Section 1725.5.

**AGREEMENT FOR PROFESSIONAL CONSULTANT
SENIOR ENGINEER AND ADMINISTRATIVE SERVICES**

20. (a) The Consultant shall deliver to the [Public Works Director/City Engineer or his/her designated representative](#), fully completed and detailed WORK-related documents which shall become the property of the City. The Consultant may retain, for its files, copies of any and all material, including drawings, documents, and specifications, produced by the Consultant in performance of this Agreement.

(b) The Consultant shall be entitled to copies of all furnished materials for his files and his subconsultants, if any.

(c) The City agrees to hold the Consultant free and harmless from any claim arising from any unauthorized use of computations, maps, and other documents prepared or provided by the Consultant under this Agreement, if used by the City on other work without the permission of the Consultant. Consultant acknowledges that Consultant work product produced under this agreement may be public record under State law.

21. (a) This Agreement shall terminate without any liability of City to Consultant upon the earlier of: (i) Consultant's filing for protection under the federal bankruptcy laws, or any bankruptcy petition or petition for receiver commenced by a third party against Consultant; (ii) 10 calendar days prior written notice with or without cause by City to Consultant; (iii) City's non-appropriation of funds sufficient to meet its obligations hereunder during any City fiscal year of this Agreement, or insufficient funding for the WORK; or (iv) expiration of this Agreement. The written notice shall specify the date of termination. Upon receipt of such notice, the Consultant may continue services on the WORK through the date of termination, provided that no service(s) shall be commenced or continued after receipt of the notice, which is not intended to protect the interest of the City. The City shall pay the Consultant within thirty (30) days after the date of termination for all non-objected to services performed by the Consultant in accordance herewith

**AGREEMENT FOR PROFESSIONAL CONSULTANT
SENIOR ENGINEER AND ADMINISTRATIVE SERVICES**

through the date of termination. Consultant shall not be paid for any work or services performed or costs incurred which reasonably could have been avoided.

(b) In the event of termination due to failure of Consultant to satisfactorily perform in accordance with the terms of this Agreement, City may withhold an amount that would otherwise be payable as an offset to, but not in excess of, City's damages caused by such failure. In no event shall any payment by City pursuant to this Agreement constitute a waiver by City of any breach of this Agreement which may then exist on the part of Consultant, nor shall such payment impair or prejudice any remedy available to City with respect to the breach.

(c) Upon any breach of this Agreement by Consultant, City may (i) exercise any right, remedy (in contract, law or equity), or privilege which may be available to it under applicable laws of the State of California or any other applicable law; (ii) proceed by appropriate court action to enforce the terms of the Agreement; and/or (iii) recover all direct, indirect, consequential, economic and incidental damages for the breach of the Agreement. If it is determined that City improperly terminated this Agreement for default, such termination shall be deemed a termination for convenience.

(d) Consultant shall be liable for default unless nonperformance is caused by an occurrence beyond the reasonable control of Consultant and without its fault or negligence such as, acts of God or the public enemy, acts of City in its contractual capacity, fires, floods, epidemics, quarantine restrictions, strikes, unusually severe weather, and delays of common carriers. Consultant shall notify City in writing as soon as it is reasonably possible after the commencement of any excusable delay, setting forth the full particulars in connection therewith, and shall remedy such occurrence with all reasonable dispatch, and shall promptly give written notice to Administrator of the cessation of such occurrence.

22. This Agreement is binding upon the City and the Consultant and their successors

**AGREEMENT FOR PROFESSIONAL CONSULTANT
SENIOR ENGINEER AND ADMINISTRATIVE SERVICES**

and assigns. Except as otherwise provided herein, neither the City nor the Consultant shall assign, sublet, or transfer its interest in this Agreement or any part thereof without the prior written consent of the other.

23. A City representative shall be designated by the City and a Consultant representative shall be designated by the Consultant. The City representative and the Consultant representative shall be the primary contact person for each party regarding performance of this Agreement. The City representative shall cooperate with the Consultant, and the Consultant's representative shall cooperate with the City in all matters regarding this Agreement and in such a manner as will result in the performance of the services in a timely and expeditious fashion.

24. This Agreement represents the entire and integrated Agreement between the City and the Consultant, and supersedes all prior negotiations, representations or Agreements, either written or oral. This Agreement may be modified or amended only by a subsequent written Agreement signed by both parties.

25. Where the payment terms provide for compensation on a time and materials basis, the Consultant shall maintain adequate records to permit inspection and audit of the Consultant's time and materials charges under this Agreement. The Consultant shall make such records available to the City at the Consultant's office during normal business hours upon reasonable notice. Nothing herein shall convert such records into public records. Except as may be otherwise required by law, such records will be available only to the City. Such records shall be maintained by the Consultant for three (3) years following completion of the services under this Agreement.

26. The City and the Consultant agree, that to the extent permitted by law, until final approval by the City, all data shall be treated as confidential and will not be released to third

**AGREEMENT FOR PROFESSIONAL CONSULTANT
SENIOR ENGINEER AND ADMINISTRATIVE SERVICES**

parties without the prior written consent of both parties.

27. (a) Consultant shall comply, and require its subconsultants to comply, with all applicable (i) professional canons and requirements governing avoidance of impermissible client conflicts; and (ii) federal, state and local conflict of interest laws and regulations including, without limitation, California Government Code Section 1090 et. seq., the California Political Reform Act (California Government Code Section 87100 et. seq.) and the regulations of the Fair Political Practices Commission concerning disclosure and disqualification (2 California Code of Regulations Section 18700 et. seq.). At any time, upon written request of City, Consultant shall provide a written opinion of its legal counsel and that of any subconsultant that, after a due diligent inquiry, Consultant and the respective subconsultant(s) are in full compliance with all laws and regulations. Consultant shall take, and require its subconsultants to take, reasonable steps to avoid any appearance of a conflict of interest. Upon discovery of any facts giving rise to the appearance of a conflict of interest, Consultant shall immediately notify City of these facts in writing.

(b) In performing the work or services to be provided hereunder, Consultant shall not employ or retain the services of any person while such person either is employed by City or is a member of any City council, commission, board, committee, or similar City body. This requirement may be waived in writing by the City Manager, if no actual or potential conflict is involved.

(c) Consultant represents and warrants that it has not paid or agreed to pay any compensation, contingent or otherwise, direct or indirect, to solicit or procure this Agreement or any rights/benefits hereunder.

(d) Neither Consultant, nor any of Consultant's subconsultants performing any services on this WORK, shall bid for, assist anyone in the preparation of a bid for, or perform

**AGREEMENT FOR PROFESSIONAL CONSULTANT
SENIOR ENGINEER AND ADMINISTRATIVE SERVICES**

any services pursuant to, any other contract in connection with this WORK unless fully disclosed to and approved by the City Manager, in advance and in writing. Consultant and any of its subconsultants shall have no interest, direct or indirect, in any other contract with a third party in connection with this WORK unless such interest is in accordance with all applicable law and fully disclosed to and approved by the City Manager, in advance and in writing. Notwithstanding any approval given by the City Manager under this provision, Consultant shall remain responsible for complying with Section 25(a), above.

(e) If Consultant should subcontract all or any portion of the work to be performed or services to be provided under this Agreement, Consultant shall include the provisions of this Section 25 in each subcontract and require its subconsultants to comply therewith.

(f) This Section 25 shall survive expiration or termination of this Agreement.

28. All Plans, drawings, Specifications, reports, logs, and other documents prepared by the Consultant in its performance under this Agreement shall, upon completion of the WORK, be delivered to and be the property of the City, provided that the Consultant shall be entitled, at its own expense, to make copies thereof for its own use.

29. The laws of the State of California shall govern the rights, obligations, duties, and liabilities of the parties to this Agreement, and shall also govern the interpretation of this Agreement. Venue shall be vested in the Superior Court of the State of California, County of Riverside.

30. Consultant expressly waives any and all rights and benefits conferred upon it by the provisions of Section 1542 of the California Civil Code which reads as follows:

“A general release does not extend to claims that the creditor or releasing party does not know or suspect to exist in his or her favor at the time of

**AGREEMENT FOR PROFESSIONAL CONSULTANT
SENIOR ENGINEER AND ADMINISTRATIVE SERVICES**

executing the release and that, if known by him or her, would have materially affected his or her settlement with the debtor or released party.”

Initials

This waiver shall be effective as a bar to any and all actions, fees, damages, losses, claims, liabilities and demands of whatsoever character, nature and kind that are known or unknown, or suspected or unsuspected, including, without limitation, claims of entitlements under the California Public Employees’ Retirement System (CalPERS) that are only afforded to employees and not independent contractors. Consultant further represents and warrants that it understands this waiver and that if it does not understand this waiver, it shall seek the advice of a qualified attorney before executing this Agreement.

Consultant hereby expressly agrees to clearly and conspicuously disclose to City in writing any and all persons working for Consultant who are retirees under the California Public Employees’ Retirement System (CalPERS) whom receives a monthly CalPERS retirement allowance, which may provide services to City under the Agreement, prior to such person performing any services thereunder. Nothing herein shall be deemed or interpreted to limited a CalPERS retiree’s obligations under applicable law, rules or regulations.

SIGNATURE PAGE FOLLOWS

Attachment: Agreement with HR Green Pacific (6330 : AUTHORIZATION TO AWARD AGREEMENTS FOR PROFESSIONAL CONSULTING

IN WITNESS HEREOF, the parties have each caused their authorized representative to execute this Agreement.

City of Moreno Valley

HR Green Pacific Inc.

BY: _____
Mike Lee, City Manager

Date

BY: _____

Name: _____

TITLE: _____
(President or Vice President)

Date

BY: _____

Name: _____

TITLE: _____
(Corporate Secretary)

Date

<u>INTERNAL USE ONLY</u>
APPROVED AS TO LEGAL FORM:

City Attorney

Date
RECOMMENDED FOR APPROVAL:

Public Works Director/City Engineer

Date

- Enclosures:
- Exhibit "A" – City Scope of Services
 - Exhibit "B" – Consultant Proposal
 - Exhibit "C" – City Services
 - Exhibit "D" – Terms of Payment
 - Exhibit "E" – Insurance Requirements

Attachment: Agreement with HR Green Pacific (6330 : AUTHORIZATION TO AWARD AGREEMENTS FOR PROFESSIONAL CONSULTING

EXHIBIT "A"
REQUEST FOR PROPOSAL
2023-020
PROFESSIONAL CONSULTANT SENIOR ENGINEER SERVICES

City of Moreno Valley
14177 Frederick St.
Moreno Valley, CA 92552



RELEASE DATE: August 28, 2023

DEADLINE FOR QUESTIONS: September 11, 2023

RESPONSE DEADLINE: September 18, 2023, 2:00 pm

RESPONSES MUST BE SUBMITTED ELECTRONICALLY TO:

<https://secure.procurenow.com/portal/morenovalley>

City of Moreno Valley
REQUEST FOR PROPOSAL

Professional Consultant Senior Engineer Services

- 1. NOTICE TO BIDDERS.....
- 2. SCOPE OF SERVICES
- 3. GENERAL INFORMATION
- 4. PROPOSAL CONTENT
- 5. PROSPECTIVE BIDDER QUALIFICATIONS.....
- 6. SUBMISSION OF PROPOSALS
- 7. EVALUATION AND RANKING OF PROPOSALS
- 8. AWARD
- 9. SPECIAL TERMS AND CONDITIONS.....
- 10. Vendor Questionnaire.....

Attachments:

- A - Non-Collusion Declaration
- B - Exhibit 10-O1 Consultant Proposal DBE Commitment
- C - Exhibit 10-Q Disclosure of Lobbying Activities
- D - Sample Consultant Agreement for Professional Consultant Senior Engineer Services

Attachment: Agreement with HR Green Pacific (6330 : AUTHORIZATION TO AWARD AGREEMENTS FOR PROFESSIONAL CONSULTING

1. NOTICE TO BIDDERS

1.1. Summary

The City of Moreno Valley is seeking qualified firms whose staff has in-depth experience in project management and implementation to serve as staff extension for the City's Public Works Department to manage various capital improvement plan (CIP) projects and perform project-related senior engineer and administrative duties as assigned.

You are hereby invited to submit a proposal for providing professional consultant senior engineer services for the Public Works Department. The selected consultants could be retained to serve the City for a period of three (3) years subject to the approval of the City Council.

1.2. Background

Moreno Valley was incorporated in 1984 as a General Law City, merging the communities of Moreno, Sunnymead, and Edgemont. The City operates under a Council-Manager form of government. The City Council is comprised of an elected Mayor and four Council Members elected by district. The City has a committed customer-service oriented workforce comprised of more than 450 employees who provide a wide-range of municipal services including Public Works, Economic Development, Community Development, Parks and Community Services, Financial and Management Services and Library services. The City contracts with Riverside County for Police and Fire services.

1.3. Timeline

Due Dates and RFP-Contract Award Schedule

The Request for Proposal (RFP) release, proposal review and consultant selection processes that leads to the award of a contract for the requested services are anticipated to be completed per the following schedule:

RFP Release Date	August 28, 2023
Questions & Answer Deadline	September 11, 2023, 2:00pm
Proposal Due Date	September 18, 2023, 2:00pm
Proposal Review	September 20, 2023
City Council Awards Contract	October 3, 2023
Notice to Proceed with Services	October 23, 2023

2. SCOPE OF SERVICES

2.1. General

Under general direction, the selected staff from successful firm shall provide Professional Consultant Senior Engineer Services for a contract time of up to three (3) years subject to the approval of the City Council. The duration of work shall be on an as-needed basis.

The consultant shall manage, oversee, evaluate, monitor, and participate in the management of multiple complex capital improvement plan (CIP) projects through all phases (planning, design and construction); supervise and oversee the work of professional, technical, and administrative support staff and/or other consultants; and perform other special assignment or related senior engineer and administrative duties as assigned. Depending on the workload and project needs, City anticipates a commitment of minimum of 20 hours/week up to 40 hours/week with a requirement of two (2) full days working in-person at the City Hall.

2.2. Specific Tasks and Duties

- 2.2.1 Works independently or with staff and/or other consultants to develop, implement, and monitor work plans to achieve assigned goals and objectives; contributes to development of and monitoring of performance against the division and project budgets; participates in developing, implementing and evaluating work programs, plans, processes, systems, and procedures to achieve division and City goals, objectives and performance measures consistent with the City's quality and service expectations.
- 2.2.2 Works with staff to ensure a high performance, customer service-oriented work environment which supports achieving City objectives and service expectations; provides leadership and participates in programs and activities that promote a positive employee relations environment.
- 2.2.3 Acts as Project Manager and manages, oversees, evaluates, and monitors assigned capital improvement projects through planning, design, or construction phases; prepares and maintains detailed project cost estimates and schedules; obtains all necessary regulatory approvals and permits to implement projects; responds to requests for information and clarifies and interprets engineering issues, regulations, codes, and requirements; chairs preconstruction meetings, reviews construction schedules, and prepares preconstruction meeting minutes; verifies available project funds and prepares purchase requisitions; reviews, evaluates, processes, initiates, and prepares change orders, amendments to agreements, schedule revisions, and updates, etc.; drafts reimbursement invoices to funding agencies and ensures payment; files notices of completion with County Recorder; releases retention payments to contractors; prepares and provides regular project status reports to division management; and other close-out documentation.
- 2.2.4 Participates in the selection and supervision of project consultants and contractors; prepares requests for proposals for outside services; reviews consultant plans,

- specifications, submittals, estimates, designs, drawings, and schedules of values for completeness, accuracy, scope of work, constructability, and compliance with federal, state, and local requirements; provides recommendations for acceptable alternative solutions to design errors and other issues; interviews contractor employees and verifies compliance with federal and state prevailing wage rates and notifies contractors of discrepancies; verifies rating of contractor bonds and insurance requirements and submits to City Attorney for approval; evaluates bids and recommends awarding of contracts; monitors consultant performance and inspects work for conformance with plans and specifications; assesses, identifies and facilitates complete resolution of noncompliance issues; reviews, verifies and processes consultant and contractor invoices and pay requests for payment.
- 2.2.5 Prepares complete project bid documents which include Plans, Specifications and Estimates (PS&E). Manages and participates in advertisement and bidding processes for projects; prepares bid notices; sets bid opening times and dates and attends as assigned; prepares necessary addenda; verifies bid results and bid numbers to identify errors and omissions and provides information to the City Attorney as necessary; performs detailed records and reference checks for contractors and subcontractors; prepares and submits required documentation to funding agencies to ensure compliance with bid requirements.
- 2.2.6 Coordinates project activities with other City departments and divisions, consultants, and external agencies for plan review and permitting; conducts and facilitates regular project staff meetings.
- 2.2.7 Serves as primary liaison between the City and contractors and consultants; works with contractors, consultants, and others to resolve conflicts and facilitate solutions; inspects project sites to ensure compliance with project specifications and City policies and resolve issues.
- 2.2.8 Prepares and updates a variety of complex and technical engineering project documentation, including staff reports, bid notices, project plans and specifications, requests to advertise and adopt plans and specifications, grant applications, various notices, statements of working days, final maps, bonds, agreements, right-of-way acquisitions and other documents; drafts interagency agreements for reimbursement and conveyance of easements; prepares future project cost estimates and schedules for the City's Capital Improvement Plan.
- 2.2.9 Analyzes and responds to requests for information and complaints from other public and governmental agencies, community and business groups, citizens, the media, and the public; represents the City and makes presentations at various meetings and public hearings.

- 2.2.10 Identifies, evaluates, selects, and submits grants for City Council approval; prepares and submits applications for various federal and state grant funding programs; ensures project compliance with grant requirements.
- 2.2.11 Oversees project right-of-way acquisition processes; performs research on project areas to ensure they are within existing City rights-of-way; recommends the acquisition of additional rights-of-way as necessary.

Attachment: Agreement with HR Green Pacific (6330 : AUTHORIZATION TO AWARD AGREEMENTS FOR PROFESSIONAL CONSULTING

3. GENERAL INFORMATION

Proposals must be submitted electronically via the City of Moreno Valley e-Procurement System, OpenGov, **before the Due Date and Time as shown on Section 1.3 of this RFP**, at:

<https://procurement.opengov.com/portal/morenovalley>

The proposer shall provide a separate file for technical proposal and a separate file for cost proposal.

(Note: Cost proposals will not be opened during the review and rating of the technical proposals. Once the consultant ranking is made and top-ranked consultant is identified, only the cost proposal of the top-ranked consultant will be opened for review and contract negotiation purposes.)

Unless otherwise specified, proposals submitted by any other method such as hard copy, fax, or e-mail will be disqualified.

Proposals may be withdrawn on the OpenGov vendor portal prior to the scheduled submittal time and date for receipt of proposals.

Prospective bidder's are encouraged to not wait until deadline to submit proposals, as system-related questions may arise.

All questions, technical, commercial, or contractual in nature shall be directed to the Questions & Answers Section on the e-Procurement System, OpenGov. No phone calls will be allowed. Contact of the City of Moreno Valley personnel directly regarding this RFP is prohibited and may be grounds for elimination from the selection process. All questions regarding this RFP must be submitted through OpenGov no later than **the Questions & Answers Deadline as shown on Section 1.3 of this RFP**.

Bidders experiencing any technical difficulties with the bid submission process may contact OpenGov at (650) 336-7167 or utilize the chat bubble in the system. Neither the City, nor OpenGov, makes any guarantee as to the timely availability of assistance, or assurance that any given problem will be resolved by the bid submission deadline.

Right to Reject Proposals: City reserves the right to reject any and all proposals, to waive any non-material irregularities or informalities in any proposal, and to accept or reject any item or combination of items.

Execution of Agreement: If a prospective bidder is not able to execute an agreement within 10 days after being notified of selection, City reserves the right to select the next most qualified bidder or call for new proposals, whichever City deems most appropriate. (Sample template of agreement is attached).

Incorporation of RFP/Proposal: This RFP and the firm's response, including all promises, warranties, commitments, and representations made in the successful proposal will become binding contractual obligations and will be incorporated by reference in any agreement between City and prospective bidder.

Authorized Signatories: Company personnel signing the cover letter of the proposal, or any other related forms submitted must be authorized signers with the requisite authority to represent their firm and to enter into binding contracts.

Request For Proposal #2023-020
Title: Professional Consultant Senior Engineer Services

Validity of Proposals: Proposed services and related pricing contained in the proposal must be valid for a period of 60 Days after the due date.

Attachment: Agreement with HR Green Pacific (6330 : AUTHORIZATION TO AWARD AGREEMENTS FOR PROFESSIONAL CONSULTING

4. PROPOSAL CONTENT

The Consultant's Proposal shall be no more than 20 pages, excluding executive summary, resumes, dividers, and certificates. Proposals failing to provide sufficient information and assurances of performance to accurately assess each category of the required services and failing to comply with requirements and conditions of the RFP will not be given further consideration.

4.1. Executive Summary

The Consultant shall include an executive summary with general firm's information including full legal name and contact information, organizational structure (corporation, LLC, etc.), name(s) and title(s) of the principal owner(s), person(s) authorized to make commitments for your company identified in the corporate resolution, firm history and length of relevant experience, and current number of employees with emphasis on key personnel. The executive summary shall be limited to a maximum of one page.

4.2. Technical Proposal

The Consultant shall include, but not be limited to, the following items in the body of the proposal:

- 4.2.1 Proposer's approach and understanding of all necessary tasks and steps involved in completing the required services.
- 4.2.2 Responses with sufficient detail to enable City to evaluate your understanding of City's requirements, the suitability of your services and/or product(s) to meet City's requirements, the strength of your work plan, previous experience, and current workload.
- 4.2.3 A detailed work plan to reflect the methods and procedures that the proposer intends to use to provide the required services. The scope of services outlined in this RFP is only provided as a guide and does not include all the tasks as required to complete the work.
- 4.2.4 A list of deliverables or goals to be achieved for this service contract.
- 4.2.5 Procedures for perform Quality Assurance and Quality Control (QA/QC) on the services to be provided.
- 4.2.6 Related experience including relevant experience date, name of agency, and reference name/contact information.
- 4.2.7 A resource allocation matrix (exclude cost information).

4.3. Proposed Staff/Team

- 4.3.1 Information on key personnel who is expected to remain in service until completion of the contract.
- 4.3.2 Information on the back-up personnel in the event of the key personnel not available to provide the contracted services for certain short period during the contract duration.
- 4.3.3 Provide resumes of proposed staff/team members.

4.4. Required Statements

The Consultant's Proposal shall include the following:

- 4.4.1 A statement that this RFP shall be incorporated in its entirety as a part of the Consultant's Proposal.
- 4.4.2 A statement that this RFP and the Consultant's Proposal will jointly become part of the Agreement for Professional Consultant Services for this project when said Agreement is fully executed by the Consultant and the City Manager of Moreno Valley.
- 4.4.3 A statement that the Consultant's Services to be provided, and fees therefore, will be in accordance with the City's RFP except as otherwise specified in the Consultant's Proposal under the heading "ADDITIONS OR EXCEPTIONS TO THE CITY'S REQUEST FOR PROPOSAL."
- 4.4.4 A single and separate section with the heading "ADDITIONS OR EXCEPTIONS TO THE CITY'S REQUEST FOR PROPOSAL" (if needed) containing a complete and detailed description of all of the exceptions to the provisions and conditions of this Request for Proposal upon which the Consultant's Proposal is contingent and which shall take precedent over this RFP.
- 4.4.5 A statement of qualifications applicable to this project including the names, qualifications and proposed duties of the Consultant's Staff to be assigned to this project; a listing of recent similar projects completed including the names, titles, addresses and telephone numbers of the appropriate persons whom the City could contact. If one or more of the Consultant's staff should become unavailable, the Consultant may substitute other staff of at least equal competence only after prior written approval by the City.
- 4.4.6 A resource allocation matrix must be submitted with the Proposal. The resource allocation matrix must list detailed tasks in rows and the appropriate individual (Job Title Only) as well as the number of hours that these individuals will be working on each task listed, will be included in adjacent columns. The resource allocation matrix and the project design schedule are required of both the primary consultant, as well as any sub-consultant. In addition, the applicable construction support services consultant must list the type and number or hours of geotechnical tests being proposed, as well as the type and number of hours of inspection or survey work within the Proposal. Failure to do so will result in the Consultant's Proposal being deemed incomplete and it will not receive further consideration. The construction support services Consultant is not required to provide a Project Schedule with milestones.
- 4.4.7 A statement of sub-consultant's (include relief personnel) qualifications applicable to this project including the names, qualifications and proposed duties of the sub-consultant's staff to be assigned to this project; a listing of recent similar projects completed including the names, titles, addresses, and telephone numbers of the appropriate persons whom the City could contact.
- 4.4.8 A statement that the Consultant acknowledges and understands that the Consultant will not be allowed to change the sub-consultant without written permission from the City.
- 4.4.9 A statement that all charges for Consultant (construction) services is a "Not-to-Exceed Fee" which must include conservatively estimated reimbursable expenses, as submitted with and made a part of said Consultant's Proposal.
- 4.4.10 A statement that the Consultant will document and provide the results of the work to the satisfaction of the City. This may include preparation of field and final reports, or similar evidence of attainment of the Agreement objectives.
- 4.4.11 A statement that the Consultant will immediately document and notify the City of any defects or hazardous conditions observed in the vicinity of the project site prior, during, or after the construction work.

- 4.4.12 A copy of the Consultant's hourly rate schedule and a statement that said hourly rate schedule is part of the Consultant's Proposal for use in invoicing for progress payments and for extra work incurred that is not part of this RFP. An itemized cost breakdown for the work described herein must be submitted in a separate file, entitled Cost file, as part of the Consultant's Proposal submittal. All extra work will require prior approval from the City.
- 4.4.13 A statement that the Consultant will not discriminate against any employee or applicant for employment because of race, color, religion, sex, or national origin.
- 4.4.14 A statement that all federal laws and regulations shall be adhered to notwithstanding any state or local laws and regulations. In a case of conflict between federal, state or local laws or regulations the strictest shall be adhered to.
- 4.4.15 A statement that the Consultant shall allow all authorized federal, state, county, and City officials access to place of work, books, documents, papers, fiscal, payroll, materials, and other relevant contract records pertinent to this special project. All relevant records shall be retained for at least three years.
- 4.4.16 A statement that the Consultant shall comply with the Davis-Bacon Fair Labor Standards Act (40 USC 276-a through a-7), and the implementation regulations issued pursuant thereto (29 CFR Section 1, 5), any amendments thereof and the California Labor Code. Pursuant to the said regulations, entitled "Federal Labor Standards Provisions," Federal Prevailing Wage Decision" and State of California prevailing wage rates, respectively.
- 4.4.17 A statement that the Consultant shall comply with the Copeland Anti-Kickback Act (18 USC 874) and the Implementation Regulation (29 CFR 3) issued pursuant thereto, and any amendments thereof.
- 4.4.18 A statement that the Consultant offers and agrees to assign to the City all rights, title, and interest in and to all causes of action it may have under Section 4 of the Clayton Act (15 USC Sec. 15) or under the Cartwright Act (Chapter 2 [commencing with Section 16700] of Part 2 of Division 7 of the Business and Professions Code), arising from purchases of goods, services, or materials pursuant to the public works or the subcontract. This assignment shall be made and become effective at the time the City tenders final payment to the Consultant, without further acknowledgment by the parties.

4.5. [Required Forms](#)

- 4.5.1 Non-Collusion Declaration Form
- 4.5.2 Exhibit 10-O1, Consultant Proposal DBE Commitment
- 4.5.3 Exhibit 10-Q, Disclosure of Lobbying Activities

4.6. [Cost Proposal](#)

- 4.6.1 A Cost Proposal that includes all costs associated with the requested services for the anticipated service length of up to three (3) years.
- 4.6.2 A rate schedule aligned with titles in the resource allocation matrix in Technical Proposal.
- 4.6.3 The general Scope of Services outlined herein is only provided as a guide in this Request for Proposal.

4.6.4 Itemized tasks and corresponding costs must be identical to the detailed Scope of Services included as part of the Proposer’s Technical Proposal.

Attachment: Agreement with HR Green Pacific (6330 : AUTHORIZATION TO AWARD AGREEMENTS FOR PROFESSIONAL CONSULTING

5. PROSPECTIVE BIDDER QUALIFICATIONS

5.1. Prospective Bidder Qualifications

The intent of this RFP is to evaluate the proposals, determine the prospective bidder's that are in the competitive range, and select proposers that will provide the highest level of professional services for City.

5.2. Minimum Qualifications:

The proposed staff who will be providing consultant senior engineer services shall have the knowledge of:

- 5.2.1 Theories, principles and practices of civil engineering design and construction.
- 5.2.2 Principles and modern techniques and commonly used materials and equipment used in design, construction, and maintenance of various public works projects.
- 5.2.3 Federal, state, and local laws, regulations, and court decisions applicable to public works projects.
- 5.2.4 Information technology and computer capabilities to perform daily engineering tasks.
- 5.2.5 Principles and practices of sound business communication, teamwork, and work ethics.

The proposed staff shall also possess the ability to:

- 5.2.6 Prepare, direct preparation of and review complex engineering designs, plans, specifications, and legal contracts.
- 5.2.7 Perform difficult technical research and analyze complex engineering and mathematical problems, evaluating alternatives and recommending or adopting effective courses of action.
- 5.2.8 Plan, organize, manage, and integrate engineering design and construction activities.
- 5.2.9 Design issues, analyze problems, evaluate alternatives, and develop sound and independent judgements and recommendations.
- 5.2.10 Understand, interpret, explain, and apply federal, state, and local policy, law, regulations, and court decisions applicable to public works project implementation.
- 5.2.11 Operate a personal computer using standard or customized software applications appropriate to assigned tasks.
- 5.2.12 Supervise and evaluate the work of professional consultants and construction contractors.
- 5.2.13 Prepare clear, concise, and comprehensive correspondence, reports, and other written materials.
- 5.2.14 Organize, set priorities, and exercise sound independent judgement within areas of responsibility.

- 5.2.15 Exercise tact and diplomacy in dealing with sensitive and complex issues and situations.
- 5.2.16 Establish and maintain effective working relationships with City management, staff, contractors, consultants, representatives of other governmental and utility agencies, business and community groups, citizens, the public and others encountered in the course of work.

5.3. Education, Training, and Licenses:

- 5.3.1 A bachelor's degree in civil engineering.
- 5.3.2 A minimum of five years of professional civil engineering experience.
- 5.3.3 At least three years' experience in a supervisory or program management capacity.
- 5.3.4 A valid California Civil Engineering License.
- 5.3.5 A valid California driver's license and the ability to maintain insurability under City's vehicle insurance policy.

6. SUBMISSION OF PROPOSALS

Written responses to the RFP must be prepared as specified in proposal content, as to form, content, and sequence. No changes to responses may be made after the submittal deadline.

The Proposal for the requested shall be uploaded to OPENGOV on or before, but no later **the Date and Time as shown on Section 1.3 of this RFP**. Any responses received after this time will not be considered by the City.

The response shall be signed by an officer, or officers, authorized to execute legal documents on behalf of the respondent.

The City reserves the right to waive informalities in any proposal, to reject any or all proposals, to reject one part of a proposal and accept the other, except to the extent that proposals are qualified by specific limitations, and to make awards to the Consultants whose proposal is most beneficial to the needs of the City. Bidders are solely responsible for on time submission of their electronic bid. The City will only consider bids that have been transmitted successfully and have been issued an ebid confirmation number with a time stamp from the Bid Management System indicating that the bid was submitted successfully. Transmission of bids by any other means will not be accepted. Bidders shall be solely responsible for informing themselves with respect to the proper utilization of the bid management system, for ensuring the capability of their computer system to upload the required documents, and for the stability of their internet service. Failure of the bidders to successfully submit electronic bids shall be at the bidders' sole risk and no relief will be given for late and/or improperly submitted bids. Bidders experiencing any technical difficulties with the bid submission process may contact OpenGov at (650) 336-7167 or utilize the chat bubble in the system. Neither the City, nor OpenGov, makes any guarantee as to the timely availability of assistance, or assurance that any given problem will be resolved by the bid submission deadline.

7. EVALUATION AND RANKING OF PROPOSALS

In accordance with the Chapter 3.12 PURCHASING City Municipal Code's objective of selecting the most qualified consultant for providing the requested services, a Review Board which is composed of appropriate staff representatives and/or qualified outside representatives, will review the proposals received and select the most qualified firms. Review Board shall rank the prospective bidder's based upon the following criteria:

No.	Evaluation Criteria	Scoring Method	Weight (Points)
1.	<p>The Firm's General Experience and Qualification Information (20 points)</p> <p>Information about the company (and all sub-Consultants) including professional licenses held; ability to furnish required insurance and meet stipulations of the City's "boiler plate" agreement; details about comparable projects completed by the firm, as well as local experience; and its ability to provide the required services in an efficient and expeditious manner.</p>	0-100 Points	20 (20% of Total)
2.	<p>Experience of Key Personnel (60 points)</p> <p>Background on key personnel (including all sub-consultants) qualifications, abilities, familiarity with state and federal procedures, local experience on comparable projects and length of service with the firm, reference information preferably with municipal agencies, and proven track record and depth of understanding/knowledge of the proposed staff.</p>	0-100 Points	60 (60% of Total)
3.	<p>3. Project Approach/Understanding (20 points)</p> <p>Understanding of requested services and how the Consultant team plans to address them; the approach, methods, and procedures to be used on managing and implementing CIP projects; the management approach and organization necessary to complete the specific project or projects; and outline quality control measures to ensure delivery of a quality services on time, within budget that provides a cost efficient, timely and predictable execution of the project implementation.</p>	0-100 Points	20 (20% of Total)

8. AWARD

- 8.1 After conclusion of the Evaluation and Ranking of Proposals processes, a Notification of Intent to Award may be sent to any prospective bidder's selected. City may make multiple awards.
- 8.2 Award is contingent upon the successful negotiation of final contract terms and the approval of City. Negotiations shall be confidential and not subject to disclosure to competing prospective bidder's unless an agreement is reached. If contract negotiations cannot be concluded successfully, City may negotiate a contract with the next best qualified prospective bidder's or withdraw the RFP. In the event City does not approve the recommendation to award, the RFP may be cancelled without any cost or obligation of City.
- 8.3 Prices are firm fixed prices during each contract period.
- 8.4 Prices shall be negotiated for each mutually exercised optional renewal period.

9. SPECIAL TERMS AND CONDITIONS

9.1. Termination

- 9.1.1 If, in the opinion of the City of Moreno Valley, the awarded consultant fails to perform or provide prompt, efficient service, the City must have the right to terminate or cancel the Agreement upon 10 calendar day's prior written notice with or without cause and pay Consultant for the value of the actual work satisfactorily performed to the date of termination.
- 9.1.2 The City of Moreno Valley must have the right to terminate or cancel the Agreement upon 30-day's written notice without cause and pay Consultant for the value of actual work satisfactorily performed to the date of termination.
- 9.1.3 These rights are in addition to any other rights that City may have available.

9.2. Public Employees Retirement Law (CalPERS)

- 9.2.1 CalPERS Indemnity. To the fullest extent permitted by law, in addition to obligations set forth in this section, in the event that any person providing services under this Agreement is determined by a court of competent jurisdiction or CalPERS to be eligible for enrollment in CalPERS as an employee of the City, to the fullest extent of the law, Consultant shall indemnify, defend, and hold harmless City for any costs and expenses incurred by City, including without limitation, payment that City is required as a result to make to CalPERS, whether in the form of employee and/or employer contributions, taxes, or any similar obligations, as well as for the payment of any penalties and interest.
- 9.2.2 CalPERS Participation. As set forth in this Agreement and in the Request for Proposal, City has an obligation to treat all persons working for or under the direction of Consultant as an independent contractor of City and agents and employees of Consultant, and not as agents or employees of City. Consultant and City acknowledge and agree that City participates in a defined benefit plan ("CalPERS"), and that it is possible that CalPERS may find that persons providing services pursuant to this Agreement are employees of City and should be registered with the CalPERS as employees of City.
- 9.2.3 CalPERS Retiree Disclosure. Consultant hereby expressly agrees to clearly and conspicuously disclose to City in writing any and all persons working for Consultant who are retirees under the California Public Employees' Retirement System (CalPERS) whom receives a monthly CalPERS retirement allowance, and whom are, subject to City approval, assigned by Consultant to provide services to City under the Agreement, prior to such person performing any services hereunder. Nothing herein shall be deemed or interpreted to limit a CalPERS retiree's obligations under applicable law, rules or regulations.
- 9.2.4 Joint Cooperation. In the event that CalPERS initiates an inquiry that includes examination of whether individuals providing services under this Agreement to City are City's employees, Consultant shall within five days and share all communications and documents from CalPERS that it may legally share. In the event that either Consultant or City files an appeal or court challenge, Consultant and City each agree to cooperate with each other in responding to the inquiry and any subsequent administrative appeal or court challenge of an adverse determination.

9.3. Managing Federal and State Funded Projects

As part of the senior engineer services, the Consultant may be assigned to manage certain federal and state funded projects under FHWA, HUD, FEMA, and/or State Bills (SB). The work and/or services to be provided by the Consultant shall comply with all pertinent local, State, and Federal laws and regulations. The Consultant, therefore, shall be legally able to perform services for Federal or State funded projects.

A contract DBE goal has not established for the purpose of this RFP. However, the Consultant is required to submit the Consultant Proposal DBE Commitment (Exhibit 10-O1) as included in this RFP along with the proposal to meet Caltrans Local Assistance DBE commitment requirements. Prior to starting to work on a Federal or State funded project, the Consultant shall submit to the City for approval the Consultant Contract DBE Commitment (Exhibit 10-O2) with the Contract DBE Goal specifically determined/approved for that project.

The Consultant shall also be required to submit the Disclosure of Lobbying Activities (Exhibit 10-Q) as included in this RFP along with the proposal.

9.4. 9.4 Indemnification

- 9.4.1 Design Professional Services. To the fullest extent permitted by law, including but not limited to Civil Code Section 2782.8, in performing “design professional services” as defined in Section 2782.8, the Consultant agrees to indemnify, defend, and save the City, the Moreno Valley Community Services District (CSD), and the Moreno Valley Housing Authority (MVHA), their officers, agents and employees harmless from any and all liability, claims, demands, damages, or injuries to any person, including injury to the Consultant's employees, and all claims which arise from or are connected with the negligent, reckless, or willful misconduct in the performance of or failure to perform the work or other obligations of the Consultant under this RFP and/or related Agreement, or are caused or claim to be caused by the negligent, reckless or willful misconduct of the Consultant, its officers, agents or employees, or its subconsultant(s) or any person acting for the Consultant or under its control or direction; provided, however, that this indemnification and hold harmless shall not include claims arising from the sole negligence or willful misconduct of the City, MVHA, and CSD, their officers, agents or employees.
- 9.4.2 For all non-design professional services, Consultant shall indemnify, defend, and save the City, the Moreno Valley Community Services District (CSD), and the Moreno Valley Housing Authority (MVHA), their officers, agents and employees harmless from any and all liability, claims, demands, damages, or injuries to any person, including injury to the Consultant's employees and all claims which arise from or are connected with the performance of or failure to perform the work or other obligations of the Consultant, or are caused or claim to be caused by the acts of the Consultant, its officers, agents or employees, or its subconsultant(s) or any person acting for the Consultant or under its control or direction; provided, however, that this indemnification and hold harmless shall not include claims arising from the sole negligence or willful misconduct of the City, MVHA, and CSD, their officers, agents or employees.
- 9.4.3 The protections in this Section shall be in addition to those set forth in Section 9.2 of this Request for Proposals.

10. VENDOR QUESTIONNAIRE

10.1. Please download the documents below, complete and upload.*

Please download the below documents, complete, and upload.

- [\[B\] Exhibit 10-O1 Consultant...](#)
- [\[C\] Exhibit 10-Q Disclosure...](#)
- [Non-Collusion Declaration.pdf](#)

*Response required



Professional Consultant Senior Engineer Services

PROPOSAL FOR

City of Moreno Valley

SEPTEMBER 18, 2023



Attachment: Agreement with HR Green Pacific (6330 : AUTHORIZATION TO AWARD AGREEMENTS FOR PROFESSIONAL CONSULTING

Steve Loriso, PE, QSD/QSP

1260 Corona Pointe Court, Suite 305
Corona, CA 92879-5013

Direct 951.475.3619 + Mobile 909.630.2577

sloriso@hrgreen.com



P A C I F I C

Department of Public Works
City of Moreno Valley
14177 Frederick Street
Moreno Valley, CA 92553

September 18, 2023

▶ 1260 Corona Pointe Court | Suite 305
Corona, CA 92879
Main 855.900.4742 + Fax 713.965.0044
▶ HRGREEN.COM

Re: Professional Services for Senior Engineer Consultant Services #2023-020

Dear Selection Committee Members,

The decision by Moreno Valley to continue “**Momentum MoVal**” reinforces infrastructure improvements throughout the City. This is evident in the proposed \$26,000,000 worth of streets and highways projects over the next two years, which accounts for 50% of the capital projects budget, in addition to the approximately \$20,000,000 spent on pavement rehabilitation over the past two years. In order to continue delivering these projects, along with the other \$25,000,000 worth of projects, **the City requires a responsive, multi-faceted engineering firm that prioritizes communication, quality, integrity, documentation, proficiency, and stewardship to protect your interests and realize your vision.** The City needs assurances that oversight and execution of design and construction projects are carried out by a team that has the City’s best interest in mind.

HR Green Pacific, Inc. (HR Green) differentiates itself by **exclusively serving public agencies, leveraging technology, demonstrating a successful track record delivering projects**, providing scalable solutions, and offering alternative service delivery options to maximize funding sources and efficiency. **HR Green’s** experience providing project management/staff augmentation services to clients throughout Southern California will assist in the **integration into Moreno Valley’s culture and processes to successfully deliver any of the capital projects.**

As you will see in our proposal, **our proposed Senior Engineer, Mike Aguilar, PE, has managed capital projects through different stages and has been recognized for his community driven project management approach** as well as for his project delivery. As requested on the RFP, Mike will be available 20-40 hours per week, as needed to provide project management services. We recognize the complexity of some of the City’s projects and the time and commitment required to provide quality deliverables, as such, we are proposing additional staff as part of the support team. If agreed to by the City, Jorge Perez and Berlyn Pimentel will support Mike on some daily tasks to the extent generally shown on the resource allocation matrix.

Required Information

HR Green Pacific, Inc., 1260 Corona Pointe Court, Suite 305, Corona, CA 92879, Phone: 855.900.4742, Fax: 713.965.0044, Email: sloriso@hrgreen.com, Website: www.HRGreen.com. We are a Corporation and an employee-owned business. Some of the corporate officers include: Richard White, President; Michelle Byard, Chief Financial Officer/Treasurer; and George A. Wentz, Vice President. Additional corporate officers can be provided if requested. All of the above are authorized to make commitments for our company. **HR Green** was founded in 1913 and is celebrating 110 years of engineering and design experience. We currently have over 700 employees with 60+ staff based at our headquarters in nearby Corona.

We will protect the City’s best interests by providing comprehensive, quality, responsive, technically proficient, and timely services in an on-call environment. You can have confidence that our staff will protect your interests, anticipate your needs, and proactively communicate with you throughout all phases and tasks of the work you assign to us.

The Management Contact will be George A. Wentz, PE who is authorized to sign an agreement for HR Green. The CIP Project Manager will be Steve Loriso, PE who will be responsible for the day-to-day management of the contract.

Sincerely, **HR GREEN PACIFIC, INC.**

Steve Loriso, PE, QSD/QSP
CIP Project Manager

George A. Wentz, PE
Vice President

Attachment: Agreement with HR Green Pacific (6330 : AUTHORIZATION TO AWARD AGREEMENTS FOR PROFESSIONAL CONSULTING

4.1 Executive Summary *precedes this page*

4.2 Technical Proposal 1

4.3 Proposed Staff/Team 12

4.4 Required Statements 18

4.5 Required Forms i

Appendix - Additions or Exceptions to the City’s Request for Proposaliv

4.6 Cost Proposal *under separate cover*



4.2 Technical Proposal

4.2.1 Approach and Understanding

The list of project types/services identified within the RFP and from our research of the City's CIP are all consistent with the successful services the HR Green team has provided for many other agencies. While the types of projects/services are broad, we have provided an overall approach to the delivery of capital projects that is consistent with our past experiences with the City of Moreno Valley as well as other local agencies. As the City identifies which projects will be managed by HR Green, Mike Aguilar, our Project Manager, will meet with the City to clarify the scope requirements, budget and schedule. This kick-off meeting will also serve to identify any support HR Green staff that will handle non-engineering tasks to maintain an efficient process.

Our primary goal for the City is to implement a management, staffing and resource plan, assign appropriate administrative services, create best practices and a service delivery model for the City's needs. We will align our services to your mission and expectations, and provide the best value, quality, and operational efficiency by incorporating the latest technology, paperless processes, public outreach (as necessary) and streamlined communication amongst all parties.

Although more than 50% of the CIP projects for the next two years are streets and highways, there are other categories of projects identified in the CIP that may require additional experience to manage the development of the specific project type. This is where Mike can engage HR Green resources, as needed, to ensure the proper information is incorporated into requests for proposal, bid documents, and project closeout.

The Detailed Work Plan will provide further details of how HR Green will accomplish the City of Moreno Valley's goals in providing the project management services to deliver the assigned capital projects.

4.2.2 Strength of Work Plan

HR Green as a company, has many years of experience providing project management services for a variety of other municipalities including the Cities of Moreno Valley, Jurupa Valley, Palos Verdes Estates, Pomona, and Palm Desert. More specifically, Mike Aguilar, PE, brings over 35 years of experience working with and for government agencies to complete projects with an exemplary track record of keeping projects on budget and on schedule. Mike served as a Senior Civil Engineer/Project Manager for the City of Murrieta (4.5 years) and the County of San Diego (over 10 years).

4.2.3 Detailed Work Plan

LEADERSHIP/MANAGEMENT

HR Green staff members live our values and are critical to promoting a leadership style and management approach to foster achievement of our core values below.



LEADERSHIP



PERFORMANCE



OPERATIONAL EXCELLENCE



COLLABORATION



COMMUNITY

For this contract we will assign a local, Senior Engineer, **Mike Aguilar, PE**, who is a hands-on leader with over 35 years in Capital Improvement Project (CIP) management and civil engineering. Mike has managed a spectrum of CIPs in the surrounding area and throughout Southern California, ranging from road rehabilitation projects, street widening and storm drain systems to pipeline projects, with budgets spanning from \$300,000 to \$16 million. Mike will coordinate closely with Moreno Valley and draw upon a core team of local engineering staff, all of whom have served in leadership roles with public agencies in California and/or other states. Based on the assignment at hand, Mike will verify availability and assign the right staff for the right project.

1. Receive Project Management Task from the City

Upon request from the City to manage, oversee, evaluate, monitor, and participate in the management of a project. We will lay out a road map for the project. It is one of the most critical steps in starting a project. Communicating early and often is another essential ingredient for our recipe of successfully executed senior civil engineering services.

2. Project Understanding Project Controls

After collaborating with the City regarding a specific assignment/project (via task order issuance), Mike will start reviewing the readily available information, such as the project file, and request additional information from appropriate City staff to come up with a full understanding of the project phase (planning, design, or construction) and where the project stands within that phase. Mike will then create a DRAFT Work Plan (WP) for the assigned project that will define the necessary steps and the critical path to accomplishing the assignment with key milestones that must be met to keep the project/task on schedule.

3. Project Planning, Re-sourcing, and Initiation

To perform and keep track of work assignments/projects, Mike will develop weekly project planning, monitoring, and reporting procedures such as our **Time Phased Backlog** and **Three-Month Look Ahead Schedule** to make sure that each task order has adequate resources to meet the Project Schedule. Mike will maintain decision logs for critical individual design projects that keep track of key design decisions made throughout the life of a project. The logs contain a description of the decision, the date it was made, the key decision maker, as well as the reasoning and objective of the decision. With issues being raised and decisions being made through different types of communication, phone, email, meetings, having a single document is critical.

4. Project Design Management

Our Project Design Management phase will develop plans, specifications, and estimates (PS&E) based on project needs and City requests. If desired, we can assist with preparing requests for professional design services, developing RFP packages, analyzing and recommending contract awards, and preparing staff reports for Council approval. Upon selection of a design professional, HR Green will negotiate task orders, coordinate with utilities, review preliminary and final plans and specifications, and compile input from agencies, stakeholders and the City. Our project manager will evaluate this information with you, identify necessary corrective actions, and ensure the design consultant finalizes plans and specifications accordingly. Throughout, our project manager will maintain

updated cost estimates to avoid funding surprises later. Finally, we will present the final bid package for your approval before publishing the construction bid.

5. Construction Bid and Award Support

During the Bid and Award Phase of a work assignment/project, Mike will coordinate and/or perform the following services:

- Pre-bidding conference, agenda, and meeting minutes
- Addenda (RFIs and responses)
- Bid review, analysis, and recommendations (may include Staff Report support)

Once the construction phase of a work assignment/project begins, Mike will develop submittal logs and communication sheet for distribution, continue to review and process RFI's and RCO's, along with monitoring of project schedule as submitted by the contractor. He will work with inspection staff and review daily logs to verify that the project is progressing, both within budget and on schedule. Process progress payments and review and/or recommend for approval Change Orders. He will also communicate with supporting agencies as need be on the progress of construction, as well as represent the City at community status meetings.

6. Construction Management and Inspection

Upon completion of the project/task Mike will appropriately categorize project records/files for both permanent and temporary archive, so that they may be available for reference and public record requests as needed.

7. Project Close-Out

As final Deliverable, after construction is completed, Mike will provide the following:

- Project(s) Database
- Projects Cost-Loaded Schedule
- Project Control System
- Dashboard/Progress Report
- Presentation support to Management/Council
- Process and Procedures Summary

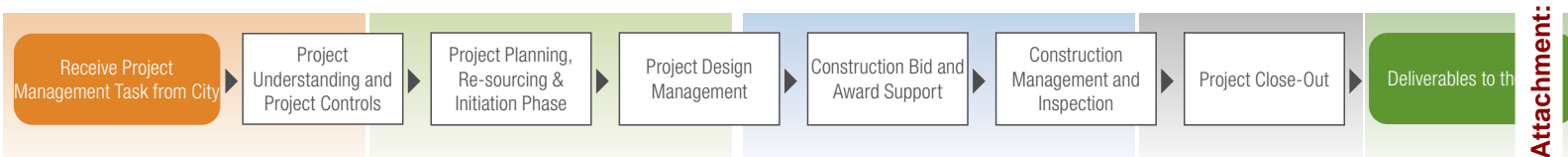

Our Client Focused Goals

HR Green’s project management goal is to **efficiently use resources to build a sustainable community that encourages economic growth and the well-being of its residents.**

Throughout the development of the projects, we will incorporate the requirements of the recently continued motto Momentum MoVal to ensure infrastructure projects are delivered with the community in mind. We will anticipate the community needs, provide rigorous project review and understanding, search for funding opportunities (if required/needed), implement best management practices in project budget allocation, and recognizing opportunities for **project optimization and budget savings.**

HR Green has reviewed Moreno Valley’s list of projects and is confident that our management and technical approach focused on planning, communication and coordination, adherence to budget and schedule, **integration of qualified staff to augment city staff,** along with our understanding of the overall importance of consistent, proactive communication will lead us to many successful project completions and meet the City’s objectives.

PROJECT MANAGEMENT DELIVERABLES

Our experience working as an extension of City staff helps us recognize the importance of maintaining detailed and accurate project records. We provide the highest level of project documentation quality to our clients. After project close-out our project manager, Mike, will make sure that the agreed upon deliverables are properly submitted to the city in digital form and hard copy if requested by the City.

As part of the HR Green’s project management approach, we will provide the following deliverables as part of the Project Management Plan:

A. General

1. Project Vision/Mission Statement and how it incorporates Momentum MoVal
2. Stakeholder List and Communication Plan.
3. Administrative Support Documents (staff reports, project information, presentations and technical reports, meeting documents, Project Cost Allocation, etc.)
4. Project Control Documents (milestone schedules, resource requirements, database, progress reports, drawing files, exhibits, etc.)

B. Design Management

1. Project Management Plans
2. Design consultant RFPs (as required per project)
3. Contingency Plan (for larger projects)
4. Plan review comment logs
5. Utilities and external agencies coordination (as required per project)
6. Project progress reports
7. Project closeout documents (staff reports, presentation and technical reports, meeting documents, budget sheets/updates)

C. Approvals and Permits

1. Record of permit submittal and requirements from external agencies.

2. Record of permit submittal and requirements from City.

D. Construction Management

1. Construction bid documents
2. Bid analysis
3. Copy of Contract (contract negotiation communication)
4. Administrative support documents (staff reports, schedule by milestone and progress, budget update sheets, etc.)
5. Management Plan (responsibility assignment matrix, emergency response plan, safety plan, QA/ Inspection plan, dispute/claims management plan)
6. RFIs
7. Change orders
8. Progress payment documentation
9. Submittals
10. Punch Lists

E. Project Closeout

1. Contract close-out records
2. Final payment documentation
3. Notice of completion and improvements acceptance
4. Bond release documents
5. Record drawings and reports

SCOPE, SCHEDULE, & BUDGET MANAGEMENT

HR Green maintains a formalized and documented project management and quality control manual adhered to by our staff. This promotes consistency of best practices and processes related to scope, schedule, and budget management. Our internal processes can be modified to coincide with specific client needs and expectations. Below are some of the best practice tools and techniques we use to complete projects within your proposed time frames.

Scope & Schedule Management

When a defined scope and budget is negotiated and prepared for a specific work order assignment, a schedule will be developed. Our staff is fluent in various scheduling tools, including Microsoft Project. Our schedules will specifically include Quality Control deliverable milestones that list the significant Quality Control activities including: task level reviews, project manager and constructability reviews, schedule reviews, budget reviews and, most importantly, construction document reviews. We will develop, resource load, baseline, and consistently monitor project progress.

Our schedule update is essential to give the City an overview of the project status, issues, budgets and most importantly, delivery date. We will include the critical path in the project schedule. Each of these tools can produce a CPM Gantt chart to identify items that are critical in the production of our work so that we can be proactive. We will be updating this schedule regularly and providing copies to the team at each Project Development Team (PDT) meeting. At the PDT meetings, we will review the schedule, task list, progress reports, and the recovery plans to be sure that we continue to make progress throughout the project lifecycle.

Decision Tracking/Risk Management

HR Green project managers maintain decision logs for critical individual design projects that keep track of key design decisions made throughout the life of a project. The logs contain a description of the decision, the date it was made, the key decision maker, as well as the reasoning and objective of the decision. With issues being raised and decisions being made through different types of communication, phone, email, meetings, having a single document is critical.

Budget Management

We will track the costs on each project through the use of our enterprise system, VantagePoint, that gives us web-based, real-time access to manage budgets and baselines; provide multiple forecasts for projected costs and revenue; and



graphically analyze and report for accurate revenue forecasts, cost management and project success.

An in-house budget tracking spreadsheet will be updated on a weekly basis to monitor project expenditures and ensure that the required work is completed within the project budget. For each task, we will utilize several tools to quickly monitor and control the labor and costs being applied to the project to maintain accountability among staff and team members, as well as keep the project aligned with the budget and schedule to allow us to make prompt changes in the allocation of resources or direction of effort in order to keep the project on track. The following tools and approaches will be utilized:

- ▶ Advanced accounting system utilizing electronic timecards provides up-to-date job cost information daily
- ▶ 24/7 web access to an array of accounting reports that will track labor, expenses, subconsultants, and all job costs
- ▶ Monthly status reports of effort expended (including subconsultants) will be generated showing real time costs to date
- ▶ Track/monitor project costs vs. actual work completed to identify areas that may be exceeding initial project budget
- ▶ Make corrective actions as necessary to the project plan to compensate for areas drifting beyond budget to bring the project back on track as soon as possible.



COMMUNICATION/COORDINATION

HR Green approaches each project in the spirit and process of the client's expectations. We have gained this experience from working with numerous clients throughout California and the U.S. (cities, counties, special districts, agencies, CALTRANS). The purpose of the Communication Process is to:

- ▶ Facilitate the project development process with the goal of reducing development time while maintaining the integrity and quality of the project;
- ▶ Foster cooperation among the client, stakeholders, and regulatory agencies; and
- ▶ Comply with the required regulatory needs of each project.

The goal of our Communication Process is to reduce, or streamline, the time required to complete the overall project development process, while ensuring consideration of impacts are evident in the design phase. Our communication effort, frequency, and consistency results in fewer surprises in the construction phase that often can negatively impact schedule and budget. Many clients have communication expectations that HR Green dovetails into each project work plan that we undertake. In addition, HR Green often utilizes previous projects communication tactics that we have found successful that align with the goals of specific new projects. For example, we have utilized the following communication vehicles to keep clients and stakeholders apprised of project information:

- ▶ Design development team daily and weekly coordination.
- ▶ Regular scheduled Project Management Team (PMT) meetings throughout the design development.
- ▶ Project controls govern internal document management that provide a registry of project activities.

- ▶ Regular scheduled stakeholder public informational meetings.
- ▶ Regular scheduled design development review meetings with clients and governing agencies.
- ▶ Website, social media, and electronic communications as agreed upon.
- ▶ Consistent design development status updates in between our project manager and the key client contact, or designated client contact via telephone, e-mail, and/or in person.
- ▶ Mailers, flyers, and/or other printed media as agreed upon.
- ▶ Other specific to client interfaces such as client information portal exchanges if required.

From an ongoing staff management perspective we have formalized performance reviews multiple times a year, establish and track key performance metrics, offer a wide variety of project management and technical training (in-house and external), as well as an open door policy for staff to approach their supervisors on any areas of concern at any time to resolve issues in a timely and constructive manner.

We are structured to seamlessly leverage thought leaders and multi-disciplined capabilities to maximize value to our public agency clients and our projects. For example, when other municipal clients approached us about additional needs, we incorporated additional personnel, oriented them to their standards and expectations, and provided the project management leadership to deliver these new services in a timely and efficient manner (design standards updates, reviews, etc.).



HR Green understands that Quality Assurance (QA) and Quality Control (QC) relies on more than just a quality product; it relies on the processes and management that it takes to deliver that product. The benefit of this to the City of Moreno Valley is working with a consultant who has established a Quality Management Plan that is distributed company-wide, which streamlines processes and identifies roles on a project-by-project basis.

Mike Aguilar, PE will be our QA/QC Manager with the responsibility for verifying that the QC processes outlined in the Quality Management Plan are adhered to by using an ongoing QA audit process. He has over 35 years of experience utilizing this role for the Counties of San Diego and Los Angeles, overseen project controls for Caltrans projects, delivered roadway projects in Riverside County, where he resides in Murrieta.

Quality Assurance / Quality Control Program Elements

1. Quality Management Plan (QMP)

A QMP will be prepared by the Project Manager and approved by the Quality Manager for each project. It will be reviewed and adopted by the team at the kickoff meeting. This plan will set forth the quality control and assurance procedures to be used, key staff and their roles and schedules for the various reviews to be conducted.

2. Risk Management Plan

A Risk Management meeting will be held and a Risk Management Plan will be prepared. The purpose of this plan is to identify and mitigate technical risks which would endanger the project schedule or budget. This meeting is chaired by the Project Manager assisted by the QM and includes all discipline leads. Example risks include determining acquisition needs, construction cost, and permitting. All three of these can delay the project, but early identification and mitigation will help keep the project moving.

3. Intra-Discipline Check

Ongoing quality control checking of documents will be the responsibility of the Task Leaders in accordance with the project QMP. The Task Leader will perform the check or assign an experienced member of the designer's discipline to complete the check. In addition, a QA review will take place prior to contract submittals to affirm the QC procedures have been followed.

4. Inter-Discipline Reviews

These reviews focus on coordination between disciplines, interference checks and systems integration. This review would take place before each submittal and be performed by senior technical staff with experience in multiple disciplines.



5. Constructibility / Value Engineering Review

Prior to each contractual submittal, a Constructibility/value engineering review will take place. This review is performed by construction staff and focuses on construction methods and techniques to identify problems and optimize schedule and cost.

6. Peer Reviews

Prior to the conceptual design completion submittal, a peer review will be performed by a senior engineer not previously involved with the project. The focus of this review will include key elements as well as mitigation issues from the Risk Management Plan.

Each team member has specific quality assurance responsibilities; however, the primary responsibility for quality assurance rests with the Project Manager. The project manager is responsible for client communications, acts as the liaison among the project team members, and is responsible for meeting the project schedule.

Attachment: Agreement with HR Green Pacific (6330 : AUTHORIZATION TO AWARD AGREEMENTS FOR PROFESSIONAL CONSULTING

Recognized Leader in Understanding What Communities Need to Work Efficiently

HR Green understands and acts on complex municipal issues. **Our staff members have served public agencies for more than 120 years combined experience.** There is also the high-profile nature of your projects which demands the experience of someone like Mike Aguilar. He has worked in the industry for over 35 years, is straightforward in his dealings, transparent in reporting, and communicates well. You will find that he is highly regarded in this field not only by his peers, but by the clients he has served over the years. You will be working with a proven team with the needed technical knowledge, and support personnel, each with practical experience and understanding of municipal operations, tailored to serve your needs. Highly accomplished in all phases of municipal administration management, **our seasoned professionals will seamlessly interface with your staff, constituents, and agency stakeholders to produce positive results.**

Technical Competency & Proficient/Innovative Solutions to Deliver Quality & Streamline Processes

On the following pages we have provided case studies of similar projects to the word that the City of Moreno Valley is seeking. The following chart provides an additional glimpse of the agencies served delivering similar services to those being requested. Additional examples and references can be provided if requested.

PROJECT SCOPE RELATED AGENCIES SERVED	SERVICES PROVIDED											TYPES OF PROJECTS					
	Project / Program Management	Staff Augmentation	Engineering Plan Review	Map Review	Land Development Coordination	City Engineer and/or City Surveyor	Design Management	PS&E Preparation	Bid / Construction Support	Technology Implementation / Electronic Review	Traffic Engineering	Traffic Operations / ITS	Roadways	Bridges / Interchanges	Wet Utilities	Dry Utilities	Drainage
City of Moreno Valley	●	●	●	●	●	●	●	●	●	●	●	●	●	●	●	●	●
City of Jurupa Valley	●	●	●	●	●	●	●	●	●	●	●	●	●	●	●	●	●
City of Hemet	●	●	●	●	●	●	●	●	●	●	●	●	●	●	●	●	●
City of Beaumont	●	●	●	●	●	●	●	●	●	●	●	●	●	●	●	●	●
City of Corona	●	●	●	●	●	●	●	●	●	●	●	●	●	●	●	●	●
City of Cathedral City	●	●	●	●	●	●	●	●	●	●	●	●	●	●	●	●	●
City of Palm Desert	●	●	●	●	●	●	●	●	●	●	●	●	●	●	●	●	●
City of Rancho Mirage	●	●	●	●	●	●	●	●	●	●	●	●	●	●	●	●	●
City of La Quinta	●	●	●	●	●	●	●	●	●	●	●	●	●	●	●	●	●
City of Lake Elsinore	●	●	●	●	●	●	●	●	●	●	●	●	●	●	●	●	●
City of Pomona	●	●	●	●	●	●	●	●	●	●	●	●	●	●	●	●	●
City of Claremont	●	●	●	●	●	●	●	●	●	●	●	●	●	●	●	●	●
City of Pico Rivera	●	●	●	●	●	●	●	●	●	●	●	●	●	●	●	●	●
City of Victorville	●	●	●	●	●	●	●	●	●	●	●	●	●	●	●	●	●
City of Hesperia	●	●	●	●	●	●	●	●	●	●	●	●	●	●	●	●	●
City of Lancaster	●	●	●	●	●	●	●	●	●	●	●	●	●	●	●	●	●
City of Upland	●	●	●	●	●	●	●	●	●	●	●	●	●	●	●	●	●
City of Palos Verdes Estates	●	●	●	●	●	●	●	●	●	●	●	●	●	●	●	●	●
County of Orange	●	●	●	●	●	●	●	●	●	●	●	●	●	●	●	●	●
County of Los Angeles	●	●	●	●	●	●	●	●	●	●	●	●	●	●	●	●	●
City of Placentia	●	●	●	●	●	●	●	●	●	●	●	●	●	●	●	●	●
City of Anaheim	●	●	●	●	●	●	●	●	●	●	●	●	●	●	●	●	●
City of Diamond Bar	●	●	●	●	●	●	●	●	●	●	●	●	●	●	●	●	●
City of Rancho Cucamonga	●	●	●	●	●	●	●	●	●	●	●	●	●	●	●	●	●

Attachment: Agreement with HR Green Pacific (6330 : AUTHORIZATION TO AWARD AGREEMENTS FOR PROFESSIONAL CONSULTING





Engineering Services

City of Jurupa Valley, California

CHALLENGE: Upon Jurupa Valley incorporation, City operations needed to hit the ground running and provide for a seamless transition from County-provided services to City-responsible services. Given our established working relationships with County/ regional stakeholders and depth of locally-accessible, available staff, HR Green has been able to handle all City Administration, Engineering, Public Works, Building & Safety, and Development needs. Over the past 10 years we have helped the City Manager and City Council identify, prioritize, and address goals/challenges, and also develop a roadmap for continuing and sustained success.

SOLUTION: Our proven approach has allowed us to leverage multi-faceted staff in different roles to do more with limited staff compared to other similar sized municipalities (cross-trained staff who can seamlessly handle multiple duties and address changing needs). We have embedded 40+ staff conceptualizing, implementing, and managing programs and projects for the public works, engineering, and building departments. Our engineers have provided overall planning, coordination and control of CIP projects (\$9+M annual CIP) from inception to completion in order to produce functionally and financially viable projects completed on time within authorized costs and to the required quality standards. Our staff members have overseen CIP projects that have been planned and designed by both HR Green personnel as well as other consultants.

BENEFIT: Due to the poor condition of City roadways upon City incorporation, estimated to cost up to \$128M to repair, HR Green aggressively pursued funding opportunities. The City has maximized the use of Measure A, Gas Tax, SB1, ATP, CalRecycle, TUMF, DIF, COP bond funds, CFDs, SB-821, HBRR, STIP, HSIP, CDBG, and developer monies to fund high-priority infrastructure needs to advance critical projects. Our staff has prepared applications and obtained \$5+M in new funding through Caltrans, the Riverside County Transportation Commission, CDBG, HSIP, CalRecycle, and other grant programs to support Safe Routes to School and Active Transportation Program (ATP) projects, beverage container recycling, and “green,” cost-effective pavement rehabilitation methods. For

REFERENCE

Rod Butler
City Manager

City of Jurupa Valley
8930 Limonite Avenue
Jurupa Valley, CA 92509
P: 951.332.6464
E: rbutler@jurupavalley.org

“The City of Jurupa Valley continues to be very pleased with the services that we are receiving from HR Green. HR Green provides highly competent and experienced staff at reasonable hourly rates. In an active and fast-growing city like Jurupa Valley, being able to supplement our internal team with well-managed contract staff makes us all the more effective in serving our residents and the development community.”

Rod Butler, City Manager,
City of Jurupa Valley



Engineering Services

City of Palos Verde Estates, California

CHALLENGE: Since 2015, HR Green has provided full staffing services, including, but not limited to building and safety administration, construction and project management, inspection, building official, plan check, city engineering, public works engineering, transportation planning, traffic engineering, CIP program management, and grant writing/administration.

SOLUTION: HR Green currently provides full-service public works engineering services. Our staff helps prioritize maintenance activities, catch basin cleaning, and placement of water quality BMPs due to El Nino.

We have successfully helped the City initiate parking modifications, including signage replacement, and prepared work orders to initiate signage and striping modifications performed by City public works staff for Malaga Cove Plaza parking modifications. We have also completed a Pavement Management Program, which was prepared by integrating data from an older program and assessed by a StreetSaver Certified Pavement Condition Rater, providing accurate insights into road conditions.

In addition, HR Green has assisted the City in preparing contract documents for advertising bids and providing project implementation/oversight for various projects, including the installation of full capture treatment systems in catch basins tributary to Machado Lake. We have also modified turning radius for a stop sign intersection to allow trucks to make a turn onto major street, Granvia Altamira at City limit entrance, utilizing AutoCAD with AutoTurn.

BENEFITS: In addition to other staff augmentation and program management services, we currently provide construction management and inspection of roadway, pavement rehabilitation, and drainage, as well as project management of forcemains. HR Green prepared the Palos Verdes Drive West Corridor Feasibility Study and has reviewed TIAs and resident requests regarding traffic issues and operations.

When requested, we have provided next-day and same-day inspections, and plan checks per designated turnaround schedule.

REFERENCE

Anastasia Seims
Public Works Director

City of Palos Verdes Estates
340 Palos Verdes Dr. West
Palos Verdes Estates, CA
90274
310.378.0383
aseims@pvestates.org

“[HR Green staff] go above and beyond to provide services to residents, contractors, utility companies, and other City Staff. [They] address every problem with a solution-oriented attitude and always strive to improve and build upon the processes in place. [HR Green] is a great asset to the City and a core member of our team.”

Anastasia Seims, Public Works
Director
City of Palos Verdes Estates

Project Management and Support

City of Pomona, California

CHALLENGE: Since 2013 HR Green has maintained various on-call construction and project management, civil engineering, plan check, and project management contracts with the City. HR Green served as an on-call consultant providing the City with design engineering, construction management, project management, civil engineering plan check and WQMP review services.

SOLUTION: We have established processes and checklists, and implemented a paperless intake/routing/tracking system to accelerate turnaround review schedules. We have provided on-call project management, staff augmentation, and plan review for the Gold Line light rail project, including the extension of the Light Rail Transit line through the City, two bridges at Garey and Town Avenues, and a flyover heavy rail west of Towne Avenue. Comprehensive review services include civil, traffic, railway, environmental and structural engineering, surveying, architecture, landscape, planning, CEQA/NEPA and related proposed work.

SAMPLE PROJECT EXPERIENCE

Mission Boulevard

Construction management for the installation of Americans with Disability Act (ADA) improvements, signal conduit and minor drainage improvements on Mission Boulevard. The \$4 million project is immediately adjacent to commercial and residential properties that needed to be kept informed as to the progress of the project as well as given advanced notice anytime access to their property would be impacted.

HR Green worked proactively with the City's contractor to minimize disruption and resident complaints. Also required oversight of contractor claims, federal funding requirements and field operations to verify the project was completed in conformance with contract documents and that the City had all the necessary documentation to be expeditiously reimbursed by state and/or federal agencies. Activities included developing an emergency response plan, QA/Inspection plan, disputes/claims management plan and a variety of documentation and records management.

REFERENCE

Matt Pilarz
City of Pomona

505 South Garey Avenue,
Pomona, CA 91766
909.602.3652
matt_pilarz@ci.pomona.ca.us

"I want to say great work to . . . the HR Green Team for their hard earned work in getting us to this point with this Clean California Grant and our Holt project. I am very pleased with the team attitude and the respect, care, and loyalty that HR Green has shown through all our projects. I am confident that we will be able to have an executed agreement and a Holt project that will deliver the criteria we have defined as we set out to make it a reality for our residents. Great work!"

Arnold E. Dichosa, PE
City Engineer

Project management is one of HR Green’s core services that we provide to numerous municipalities across Southern California. We understand that flexibility in scheduling is paramount when providing these services and we have the capability to easily scale our services to your specific needs. The proposed team has been carefully selected for numerous reasons, including their experience and availability to the City.

The proposed candidates are currently working with other municipalities on a temporary basis, but should Moreno Valley choose HR Green to fulfill your project management needs with these candidates, we will work with the City in transitioning their availability to the City to best suit your needs.

Current staff commitments/projects:

- As requested in the RFP, our proposed Senior Engineer will be available to allocate between 20-40 hours per week for project management. Mike is currently working one (1) day a week with other agencies.
- Jorge Perez, Assistant Engineer, is currently working two (2) days a week with other agencies.
- Berlyn Pimentel, Engineering Technician, is currently working two (2) days a week with other agencies.
- Our Client Services Manager, Steve Loriso, is currently working two (2) days a week with other agencies.

The following table represents an estimate for staff/resource allocation for projects. The number of hours will be based on the scope of the project assigned to HR Green by the City, our team will provide an updated resource allocation matrix at time of assignment inclusive of anticipated hours.

Our team aims to provide all project management related services as outlined in the RFP, our services are centered around quality community responsiveness and keep upfront project sustainability and budget consciousness. The matrix below shows typical tasks performed as part of project management services but it is not inclusive of all tasks that the HR Green team will be providing as part of its services.

TASK	Client Services Manager		Senior Engineer		Assistant Engineer		Engineering Technician	
	%	Hours	%	Hours	%	Hours	%	Hours
Client coordination	100%	4	0					
Project Understanding and Project Controls	2%	1	80%	40	10%	5	8%	4
Project Planning, Re-sourcing & Initiation Phase	2%	1	60%	30	30%	15	8%	4
Project Design Management	2%	1	73%	37	30%	15	0%	0
Bid / Construction Support	2%	1	50%	25	40%	20	8%	4
Construction Management and Inspection	2%	7	68%	255	20%	116	10%	60

Attachment: Agreement with HR Green Pacific (6330 : AUTHORIZATION TO AWARD AGREEMENTS FOR PROFESSIONAL CONSULTING





4.3 Proposed Staff/Team

Attachment: Agreement with HR Green Pacific (6330 : AUTHORIZATION TO AWARD AGREEMENTS FOR PROFESSIONAL CONSULTING

Key Personnel and Back-Up Personnel

Your primary point of contact is **Mike Aguilar, PE**, our assigned **Senior Engineer**. Mike will be Moreno Valley's day-to-day contact and will see that all resources are allocated to your projects as needed, serve as part of our QA/QC team, and will be available for requested meetings with the City. Mike's resume and work experience, along with that of the other key personnel, appear in the following pages.



Attachment: Agreement with HR Green Pacific (6330 : AUTHORIZATION TO AWARD AGREEMENTS FOR PROFESSIONAL CONSULTING



CERTIFICATE OF LIABILITY INSURANCE

DATE (MM/DD/YYYY)
12/14/2022

THIS CERTIFICATE IS ISSUED AS A MATTER OF INFORMATION ONLY AND CONFERS NO RIGHTS UPON THE CERTIFICATE HOLDER. THIS CERTIFICATE DOES NOT AFFIRMATIVELY OR NEGATIVELY AMEND, EXTEND OR ALTER THE COVERAGE AFFORDED BY THE POLICIES BELOW. THIS CERTIFICATE OF INSURANCE DOES NOT CONSTITUTE A CONTRACT BETWEEN THE ISSUING INSURER(S), AUTHORIZED REPRESENTATIVE OR PRODUCER, AND THE CERTIFICATE HOLDER.

IMPORTANT: If the certificate holder is an ADDITIONAL INSURED, the policy(ies) must have ADDITIONAL INSURED provisions or be endorsed. If SUBROGATION IS WAIVED, subject to the terms and conditions of the policy, certain policies may require an endorsement. A statement on this certificate does not confer rights to the certificate holder in lieu of such endorsement(s).

PRODUCER 1-800-300-0325 Holmes Murphy & Associates - CR 201 First Street SE, Suite 700 Cedar Rapids, IA 52401	CONTACT NAME: Ashley Hampsher PHONE (A/C No, Ext): 319-896-7664 E-MAIL ADDRESS: ahampsher@holmesmurphy.com FAX (A/C, No): INSURER(S) AFFORDING COVERAGE INSURER A: Zurich American Insurance Company NAIC # 16535 INSURER B: Travelers Property Casualty Company of 25674 INSURER C: XL SPECIALTY INS CO 37885 INSURER D: INSURER E: INSURER F:
INSURED HR Green Pacific, Inc. 1260 Corona Point Court Suite 305 Corona, CA 92879-5013	

COVERAGES

CERTIFICATE NUMBER: 67305304

REVISION NUMBER:

THIS IS TO CERTIFY THAT THE POLICIES OF INSURANCE LISTED BELOW HAVE BEEN ISSUED TO THE INSURED NAMED ABOVE FOR THE POLICY PERIOD INDICATED. NOTWITHSTANDING ANY REQUIREMENT, TERM OR CONDITION OF ANY CONTRACT OR OTHER DOCUMENT WITH RESPECT TO WHICH THIS CERTIFICATE MAY BE ISSUED OR MAY PERTAIN, THE INSURANCE AFFORDED BY THE POLICIES DESCRIBED HEREIN IS SUBJECT TO ALL THE TERMS, EXCLUSIONS AND CONDITIONS OF SUCH POLICIES. LIMITS SHOWN MAY HAVE BEEN REDUCED BY PAID CLAIMS.

INSR LTR	TYPE OF INSURANCE	ADDL INSD	SUBR WVD	POLICY NUMBER	POLICY EFF (MM/DD/YYYY)	POLICY EXP (MM/DD/YYYY)	LIMITS	
A	<input checked="" type="checkbox"/> COMMERCIAL GENERAL LIABILITY <input type="checkbox"/> CLAIMS-MADE <input checked="" type="checkbox"/> OCCUR GEN'L AGGREGATE LIMIT APPLIES PER: <input type="checkbox"/> POLICY <input checked="" type="checkbox"/> PRO-JECT <input checked="" type="checkbox"/> LOC <input type="checkbox"/> OTHER:			GLO373096713	01/01/23	01/01/24	EACH OCCURRENCE	\$ 2,000,000
							DAMAGE TO RENTED PREMISES (Ea occurrence)	\$ 300,000
							MED EXP (Any one person)	\$ 10,000
							PERSONAL & ADV INJURY	\$ 2,000,000
							GENERAL AGGREGATE	\$ 4,000,000
							PRODUCTS - COMP/OP AGG	\$ 4,000,000
								\$
A	<input checked="" type="checkbox"/> AUTOMOBILE LIABILITY <input checked="" type="checkbox"/> ANY AUTO <input type="checkbox"/> OWNED AUTOS ONLY <input checked="" type="checkbox"/> HIRED AUTOS ONLY <input type="checkbox"/> SCHEDULED AUTOS NON-OWNED AUTOS ONLY			BAP373096813	01/01/23	01/01/24	COMBINED SINGLE LIMIT (Ea accident)	\$ 2,000,000
							BODILY INJURY (Per person)	\$
							BODILY INJURY (Per accident)	\$
							PROPERTY DAMAGE (Per accident)	\$
								\$
B	<input checked="" type="checkbox"/> UMBRELLA LIAB <input checked="" type="checkbox"/> OCCUR <input type="checkbox"/> EXCESS LIAB <input type="checkbox"/> CLAIMS-MADE DED <input checked="" type="checkbox"/> RETENTION \$ 10,000			CUP8S97473323NF	01/01/23	01/01/24	EACH OCCURRENCE	\$ 10,000,000
							AGGREGATE	\$ 10,000,000
								\$
A	WORKERS COMPENSATION AND EMPLOYERS' LIABILITY ANY PROPRIETOR/PARTNER/EXECUTIVE OFFICER/MEMBER EXCLUDED? (Mandatory in NH) If yes, describe under DESCRIPTION OF OPERATIONS below <input type="checkbox"/> Y <input checked="" type="checkbox"/> N N/A			WC373096613	01/01/23	01/01/24	<input checked="" type="checkbox"/> PER STATUTE <input type="checkbox"/> OTHER	
							E.L. EACH ACCIDENT	\$ 1,000,000
							E.L. DISEASE - EA EMPLOYEE	\$ 1,000,000
							E.L. DISEASE - POLICY LIMIT	\$ 1,000,000
C	<input checked="" type="checkbox"/> Professional Liability (Claims Made Coverage)			DPR5006485	01/01/23	01/01/24	Per Claim	5,000,000
							Aggregate	10,000,000

DESCRIPTION OF OPERATIONS / LOCATIONS / VEHICLES (ACORD 101, Additional Remarks Schedule, may be attached if more space is required)

CERTIFICATE HOLDER To Whom It May Concern For Information Purposes Only	CANCELLATION SHOULD ANY OF THE ABOVE DESCRIBED POLICIES BE CANCELLED BEFORE THE EXPIRATION DATE THEREOF, NOTICE WILL BE DELIVERED IN ACCORDANCE WITH THE POLICY PROVISIONS. AUTHORIZED REPRESENTATIVE
---	--

ACORD 25 (2016/03)
ahampsher-cr
67305304

The ACORD name and logo are registered marks of ACORD

© 1988-2015 ACORD CORPORATION. All rights reserved.



Professional Services for Senior Engineer Services

HRGreen. City of Moreno Valley
PACIFIC

Attachment: Agreement with HR Green Pacific (6330 : AUTHORIZATION TO AWARD AGREEMENTS FOR PROFESSIONAL CONSULTING



Mike Aguilar, PE

Senior Engineer

Michael is a resident of Riverside and has over 35 years in Capital Improvement Project (CIP) management and civil engineering. Mike has managed a spectrum of CIPs, ranging from street widening and storm drain systems to pipeline projects, with budgets spanning from \$300,000 to \$16 million. He has overseen project design and construction phases, and managed project teams coordinating with numerous departments and agencies. Mike has also conducted constructability reviews, negotiated contracts, and provided construction engineering support, which has provided to significant cost reductions and streamlined processes.

Mike has worked for multiple Caltrans Districts in the delivery and schedule management of highway projects valued at up to \$500 million.

SELECTED PROJECT EXPERIENCE

► Engineering Services and CIP Management, City of Murrieta

Managed Capital Improvement Projects from \$300K to \$1.5M, including street widening of Murrieta Hot Springs Road, new street including Fig Street, and storm drain system including Old Towne Drainage Improvements. Directed the design and construction of projects, including soliciting SOQs, negotiating design contracts and design change orders. Managed environmental consultant through final approval of Mitigated Negative Declaration. Managed the bid, award, contract administration, pre-construction and weekly construction meetings. Reviewed and approved submittals. Negotiated and processed change orders to decrease and increase the original contract amount. Monitored CIP budgets and issued purchase orders for geotechnical and other services and products required to complete the construction of various projects. Coordinated with various wet and dry utility agencies to resolve utility conflicts. Reported to CIP Manager.

► Road Rehabilitation Preservation, and Engineering Services, County of Los Angeles

Inspected and prepared construction documentation for road rehabilitation projects that included digouts, coldmilling of bridge decks, scrub sealing, microsurfacing, BMP implementation, traffic control, and striping. Road rehabilitation and preservation extended over three projects with an accumulative coverage of 40 miles and an estimated value of \$4.7M. Reviewed construction submittals. Negotiated and processed change orders. Prepared project closeout documents. Reporting to Chief County Inspector.

► CIP Management, County of San Diego

Managed Capital Improvement Projects with budgets from \$500K to \$16M, including street widening, new street, storm drain systems, and road resurfacing and culvert replacement projects. Directed the design and provided construction support for projects, negotiating design contracts and design change orders. Coordinated with supporting departments, (Flood Control, Traffic, Operation and Maintenance, Survey, Construction, Property, Environmental, Accounting, Risk Management, Legal). Monitored CIP budgets and authored Budget Modification Reports as needed, drafted Board Letters, developed and made presentations to Community Planning Groups and Revitalization Meetings. Reported to the Lead Project Manager and Program Manager. Managed a staff of 4 to 9 personnel.

EXPERIENCE

35+ Years

EDUCATION

BS, Civil Engineer

REGISTRATION / LICENSE

Registered Civil Engineer, CA #44614

RECOGNITION

Letters of Recommendations from District Supervisors for Districts 1, 2, and 5.

Recognized by Community Planning Groups of Ramona, Fallbrook, Spring Valley, Valle De Oro, Lakeside, Sweetwater, Boulevard for outstanding service to the community, within San Diego County.

Commended by the City officials from the City of Murrieta and the residents for projects that improved traffic flow and enhanced the community.



Desiree Flores, PE

Senior Engineer (Back-Up)

A multi-talented and bilingual licensed civil engineer, Desiree has more than eight years of comprehensive experience providing engineering support in planning development reviews, plan review for grading and building permits, Capital Improvement Program (CIP) management and design, and structural and civil design for residential and commercial projects. Her support has included preparation of conditions of approval, meeting with developers; assistance with special assessment districts; coordination with Caltrans, Federal Emergency Management Agency (FEMA), and Union Pacific Railroad (UPRR) for special permits; review of engineering technical reports and documents; review and preparation of grading, drainage, and erosion control plans including Low Impact Development (LID) to comply with National Pollutant Discharge Elimination System (NPDES) regulations; and construction drawing review and preparation of plans for the Building and Safety Department. Desiree's background in design, sound engineering practice, constant attention to detail, and effective communication and coordination with multidisciplinary stakeholders has made her a pivotal player for the municipalities she supports.

Desiree has provided land development engineering support and has served as a liaison for various cities including the Cities of Jurupa Valley, Hemet, Pomona, Palos Verdes Estates, Claremont, and Pico Rivera.

SELECTED PROJECT EXPERIENCE

▷ CIP Design, Project / Program Management Support & Land Development Processing, City of Jurupa Valley

CIP project/program management support, infrastructure design, plan review, and Caltrans coordination. Has prepared plans and specifications for the city-wide guardrail project, a Federally-funded (HSIP) project that includes over 2,000 feet of upgraded guardrail (approximately \$90,000 in construction). She has also provided overall project management/labor compliance for the City's \$1.5 million Pedley Road safety enhancement project over 1.6 miles, a Federally-funded (HSIP) project that includes the addition of left turn lanes at six intersections along a 45MPH arterial road, and relocation of drainage headwalls and construction of storm drain modifications to accommodate the widening. Project Manager for \$500K annual slurry seal project covering 180,000 SY of slurry with pavement patching and repair. Responsibilities included labor compliance, review of contractor submittals, weekly reports, monitoring project schedule, reviewing daily inspector reports, negotiating pricing on change orders, verifying licenses, managing citizen complaints and other project administration.

▷ Design & Project / Program Management Support, City of Palos Verdes Estates

Project/program management and support to prioritize and manage CIP projects as well as designs various CIP infrastructure (road, sewer, drainage, pavement rehabilitation) projects.

▷ CIP Design & Project / Program Management Support, City of Hemet

CIP design and management, project management, quality assurance/quality control, and construction management to help prioritize and program CIP road and drainage projects involving a large backlog that needs to be expedited through design and construction.

EXPERIENCE

10 Years

EDUCATION

MS, Civil Engineering

BS, Civil Engineering

REGISTRATION / LICENSE

Professional Engineer, CA
#89868



Steve Loriso, PE, QSD/QSP

CIP Project Manager

Steve has more than 25 years of design, CIP program management, design management, plan review, NPDES/water quality compliance, and construction management experience of municipal public improvement projects. Types of projects include roads, drainage, water, sewer, traffic, grading, and parking lots. Steve has managed the implementation of the Municipal Separate Storm Sewer System (MS4) Permit for various municipalities, performed review of compliance documents for private and public developments, acted as the owner's representative and liaison between design teams and general contractors on facility and infrastructure construction projects.

Steve has served as City Engineer/Director of Public Works for several cities throughout Southern California and provided services directly to the City of Moreno Valley.

SELECTED PROJECT EXPERIENCE

▷ Citywide Pavement Rehabilitation Program, City of Moreno Valley

Program Management and Quality Control for the grind and overlay or slurry seal of streets throughout the City. In addition to the rehabilitation or maintenance of existing pavement, the project also included new signing and striping of all streets, including the addition of new Class II and Class III bikeways as well as several bicycle boulevards. **At the City's request to expedite the project, HR Green was able to complete the design of all forty miles within six (6) months.**

▷ City Engineer, City of Hemet

City Engineer overseeing land development management, CIP project management, quality assurance/quality control, and construction management to help manage land development projects and prioritize and program CIP road and drainage projects involving a large backlog that needs to be expedited through design and construction.

▷ Program Management, Cities of Hemet and Lake Elsinore

CIP management, land development management, project management, quality assurance/quality control, and construction management to help prioritize and program of CIP road and drainage projects involving a large backlog that needs to be expedited through design and construction.

▷ Civil / LID / WQMP Plan Check, Cities of Jurupa Valley, Pomona, Hemet, San Gabriel, Claremont, Monrovia, Bradbury, Norco, Chino, and Banning; County of Orange

Project Manager for the review of grading, water, sewer, drainage, street, traffic, and Stormwater Urban Mitigation Plans (SUSMPs)/Water Quality Management Plans (WQMPs) associated with residential, mixed-use, and commercial projects/developments.

▷ Municipal Engineering, City of Jurupa Valley

City Engineer responsible for managing City's Capital Improvement budget, plan checking of land development projects, overseeing the design and construction of all capital projects, facilitating the MS4 Permit and stormwater quality compliance requirements, and grant writing/administration. Some design projects have involved improvements to arterials/corridors and incorporation of Complete Streets elements. Coordinated the design and construction of Jurupa Community Services District \$60 million water and sewer CIP Program, comprised mostly of water and sewer pipeline (new and replacement) within the City right-of-way. Project Manager for design and construction of nearly \$750K worth of drainage improvements.

EXPERIENCE

25 Years

EDUCATION

BS, Civil Engineer

REGISTRATION / LICENSE

Registered Civil Engineer,
CA #64701

Qualified SWPPP
Developer/Practitioner
(QSD/QSP), CA #00503



Jorge Perez, EIT

Assistant Engineer

Jorge brings six years of construction experience for public and private sectors, including services for the City of Moreno Valley. He has performed responsibilities in geotechnical investigations, inspections and testing, construction management and cost estimating. Quality control/quality assurance background for lab testing methods and procedures according to Caltrans standards and ASTM test methods, field inspection duties and collaborating with owners, architects and contractors. His design experience includes roadway improvements, sidewalk rehabilitations, stage construction and drainage projects throughout San Bernardino County and Riverside County.

EXPERIENCE

6 Years

EDUCATION

BS, Civil Engineer

REGISTRATION / LICENSE

Engineer In Training, CA
#163747

Jorge has delivered complete construction plan sets using AutoCAD and Microstation drafting software, and is proficient with AutoCAD/Civil 3D, Microstation/InRoads, Bluebeam, Culvert Master, Hydraulic Toolbox, Procore.

SELECTED PROJECT EXPERIENCE

- ▷ Citywide Pavement Rehabilitation, City of Moreno Valley
- ▷ City Engineering for CIP FY 2022, City of Hemet
- ▷ Engineering Design Services, City of Diamond Bar



Berlyn Pimentel

Engineering Technician

Berlyn is a seasoned professional with 11 years of experience working for municipal governments including the City of Moreno Valley. She has expertise in plan review and permit processing, reviewing traffic control plans and coordinating with applicants and contractors. In addition, Berlyn has reviewed development projects for small additions, ADUs, and minor site plan modifications. She is proficient in handling public document requests and utilizing city and county GIS and records data to determine site restrictions. Berlyn has provided support to Engineering and Public Works Technicians and assisted in the annexation processes. She is skilled in accounting and financial transactions, including verification, recording, and maintenance of database records. Berlyn is proficient in customer service and translation services, and provided assistance to residents, vendors, and developers.

EXPERIENCE

11 Years

EDUCATION

Community Emergency
Response Team

College Coursework

Berlyn routinely prepares and maintains database records, and generates reports on a regular and as-needed basis, including the preparation of monthly, quarterly, and year-end financial, summary, and other technical reports in various systems, including Accela.

SELECTED PROJECT EXPERIENCE

- ▷ Citywide Pavement Rehabilitation, City of Moreno Valley
- ▷ Plan Review and Permit Processing, City of Palos Verdes Estates
- ▷ Plan Review and Permit Processing, City of Jurupa Valley



4.4 Required Statements

Attachment: Agreement with HR Green Pacific (6330 : AUTHORIZATION TO AWARD AGREEMENTS FOR PROFESSIONAL CONSULTING

- 4.4.1 HR Green agrees this RFP shall be incorporated in its entirety as a part of the Consultant's Proposal.
- 4.4.2 HR Green agrees that this RFP and the Consultant's Proposal will jointly become part of the Agreement for Professional Consultant Services for this project when said Agreement is fully executed by the Consultant and the City Manager of Moreno Valley.
- 4.4.3 HR Green agrees that the Consultant's Services to be provided, and fees therefore, will be in accordance with the City's RFP except as otherwise specified in the Appendix under the heading "ADDITIONS OR EXCEPTIONS TO THE CITY'S REQUEST FOR PROPOSAL."
- 4.4.4 HR Green has provided a single and separate section with the heading "ADDITIONS OR EXCEPTIONS TO THE CITY'S REQUEST FOR PROPOSAL" containing a complete and detailed description of all of the exceptions to the provisions and conditions of this Request for Proposal upon which the Consultant's Proposal is contingent and which shall take precedent over this RFP.
- 4.4.5 HR Green has provided qualifications applicable to this project including the names, qualifications and proposed duties of the Consultant's Staff to be assigned to this project; a listing of recent similar projects completed including the names, titles, addresses and telephone numbers of the appropriate persons whom the City could contact. Hr Green agrees that if one or more of the Consultant's staff should become unavailable, the Consultant may substitute other staff of at least equal competence only after prior written approval by the City.
- 4.4.6 HR Green has provided the requested resource allocation matrix with this proposal as part of 4.2 Technical Proposal.
- 4.4.7 HR Green does not foresee the use of any subconsultants for this contract. However, should the City require them, HR Green will provide a statement of sub-consultant's (include relief personnel) qualifications applicable to this project including the names, qualifications and proposed duties of the sub-consultant's staff to be assigned to this project; a listing of recent similar projects completed including the names, titles, addresses, and telephone numbers of the appropriate persons whom the City could contact.
- 4.4.8 HR Green agrees that the Consultant acknowledges and understands that the Consultant will not be allowed to change the sub-consultant without written permission from the City.
- 4.4.9 HR Green agrees that all charges for Consultant (construction) services is a "Not-to-Exceed Fee" which must include conservatively estimated reimbursable expenses, as submitted with and made a part of said Consultant's Proposal.
- 4.4.10 HR Green agrees to document and provide the results of the work in a manner consistent with professional standard of care. This may include preparation of field and final reports, or similar evidence of attainment of the Agreement objectives.
- 4.4.11 HR Green agrees to promptly document and notify the City of any defects or hazardous conditions observed in the vicinity of the project site prior, during, or after the construction work when such site reviews are part of Consultant's scope of work, and such reporting commensurate with professional standard of care associated with the scope as described.
- 4.4.12 HR Green's hourly rate schedule—submitted under separate cover—is part of our proposal.
- 4.4.13 HR Green agrees to not discriminate against any employee or applicant for employment because of race, color, religion, sex, or national origin.
- 4.4.14 HR Green agrees that all applicable federal laws and regulations shall be adhered to notwithstanding any state or local laws and regulations. In a case of conflict between federal, state or local laws or regulations the strictest shall be adhered to.

4.4.15 HR Green agrees to allow all authorized federal, state, county, and City officials access to place of work, books, documents, papers, fiscal, payroll, materials, and other relevant contract records pertinent to this special project. All relevant records shall be retained for at least three years.

4.4.16 HR Green agrees comply with the Davis-Bacon Fair Labor Standards Act (40 USC 276-a through a-7), and the implementation regulations issued pursuant thereto (29 CFR Section 1, 5), any amendments thereof and the California Labor Code. Pursuant to the said regulations, entitled "Federal Labor Standards Provisions," Federal Prevailing Wage Decision" and State of California prevailing wage rates, respectively.

4.4.17 HR Green agrees comply with the Copeland Anti-Kickback Act (18 USC 874) and the Implementation Regulation (29 CFR 3) issued pursuant thereto, and any amendments thereof.

4.4.18 HR Green agrees to assign to the City all rights, title, and interest in and to all causes of action it may have under Section 4 of the Clayton Act (15 USC Sec. 15) or under the Cartwright Act (Chapter 2 [commencing with Section 16700] of Part 2 of Division 7 of the Business and Professions Code), arising from purchases of goods, services, or materials pursuant to the public works or the subcontract. This assignment shall be made and become effective at the time the City tenders final payment to the Consultant, without further acknowledgment by the parties..



4.5 Required Forms

Attachment: Agreement with HR Green Pacific (6330 : AUTHORIZATION TO AWARD AGREEMENTS FOR PROFESSIONAL CONSULTING

NONCOLLUSION DECLARATION

(To be executed by Bidder and Submitted with Bid)

The undersigned declares:

I am the President of HR Green Pacific, Inc., the party making the foregoing bid.

The bid is not made in the interest of, or on behalf of, any undisclosed person, partnership, company, association, organization, or corporation. The bid is genuine and not collusive or sham. The bidder has not directly or indirectly induced or solicited any other bidder to put in a false or sham bid. The bidder has not directly or indirectly colluded, conspired, connived, or agreed with any bidder or anyone else to put in a sham bid, or to refrain from bidding. The bidder has not in any manner, directly or indirectly, sought by agreement, communication, or conference with anyone to fix the bid price of the bidder or any other bidder, or to fix any overhead, profit, or cost element of the bid price, or of that of any other bidder. All statements contained in the bid are true. The bidder has not, directly or indirectly, submitted his or her bid price or any breakdown thereof, or the contents thereof, or divulged information or data relative thereto, to any corporation, partnership, company, association, organization, bid depository, or to any member or agent thereof, to effectuate a collusive or sham bid, and has not paid, and will not pay, any person or entity for such purpose.

Any person executing this declaration on behalf of a bidder that is a corporation, partnership, joint venture, limited liability company, limited liability partnership, or any other entity, hereby represents that he or she has full power to execute, and does execute, this declaration on behalf of the bidder.

I declare under penalty of perjury under the laws of the State of California that the foregoing is true and correct and that this declaration is executed on 9-18-2023 at Corona [city], CA [state].

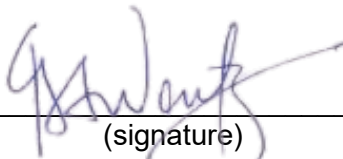
By: 
(signature)

Printed Name: George A. Wentz

Title: Vice President, Governmental Services

Attachment: Agreement with HR Green Pacific (6330 : AUTHORIZATION TO AWARD AGREEMENTS FOR PROFESSIONAL CONSULTING



EXHIBIT 10-01 CONSULTANT PROPOSAL DBE COMMITMENT

1. Local Agency: City of Moreno Valley 2. Contract DBE Goal: To be Determined (TBD)
 3. Project Description: Professional Consultant Senior Engineer Services
 4. Project Location: Within City of Moreno Valley Limits
 5. Consultant's Name: HR Green Pacific, Inc. 6. Prime Certified DBE:

7. Description of Work, Service, or Materials Supplied	8. DBE Certification Number	9. DBE Contact Information	10. DBE %
Perform project management and implementation			TBD
Local Agency to Complete this Section			
17. Local Agency Contract Number: _____ 18. Federal-Aid Project Number: _____ 19. Proposed Contract Execution Date: _____ 20. Consultant's Ranking after Evaluation: _____ Local Agency certifies that all DBE certifications are valid and information on this form is complete and accurate.		11. TOTAL CLAIMED DBE PARTICIPATION	TBD
21. Local Agency Representative's Signature _____ 22. Date _____ 23. Local Agency Representative's Name _____ 24. Phone _____ 25. Local Agency Representative's Title _____		IMPORTANT: Identify all DBE firms being claimed for credit, regardless of tier. Written confirmation of each listed DBE is required.  12. Preparer's Signature _____ Steve Loriso 13. Date _____ 9-18-2023 14. Preparer's Name _____ CIP Project Manager 15. Phone _____ 951.475.3619 16. Preparer's Title _____	

The Consultant is to fill out Exhibit 10-02 prior to working on a federal or state funded project with specific DBE goal to meet.

DISTRIBUTION: Original – Included with consultant's proposal to local agency.

ADA Notice: For individuals with sensory disabilities, this document is available in alternate formats. For information call (916) 654-6410 or TDD (916) 654-3880 or write Records and Forms Management, 1120 N Street, MS-89, Sacramento, CA 95814.



Attachment: Agreement with HR Green Pacific (6330 : AUTHORIZATION TO AWARD AGREEMENTS FOR PROFESSIONAL CONSULTING

HR Green has no lobbying activities to disclose.

EXHIBIT 10-Q DISCLOSURE OF LOBBYING ACTIVITIES

COMPLETE THIS FORM TO DISCLOSE LOBBYING ACTIVITIES PURSUANT TO 31 U.S.C. 1352

1. Type of Federal Action: <input type="checkbox"/> a. contract <input type="checkbox"/> b. grant <input type="checkbox"/> c. cooperative agreement <input type="checkbox"/> d. loan <input type="checkbox"/> e. loan guarantee <input type="checkbox"/> f. loan insurance	2. Status of Federal Action: <input type="checkbox"/> a. bid/offer/application <input type="checkbox"/> b. initial award <input type="checkbox"/> c. post-award	3. Report Type: <input type="checkbox"/> a. initial <input type="checkbox"/> b. material change For Material Change Only: year _____ quarter _____ date of last report _____
4. Name and Address of Reporting Entity <input type="checkbox"/> Prime <input type="checkbox"/> Subawardee Tier _____, if known Congressional District, if known _____	5. If Reporting Entity in No. 4 is Subawardee, Enter Name and Address of Prime: Congressional District, if known _____	
6. Federal Department/Agency: _____	7. Federal Program Name/Description: _____ CFDA Number, if applicable _____	
8. Federal Action Number, if known: _____	9. Award Amount, if known: _____	
10. Name and Address of Lobby Entity (If individual, last name, first name, MI) (attach Continuation Sheet(s) if necessary)	11. Individuals Performing Services (including address if different from No. 10) (last name, first name, MI)	
12. Amount of Payment (check all that apply) \$ _____ <input type="checkbox"/> actual <input type="checkbox"/> planned	14. Type of Payment (check all that apply) <input type="checkbox"/> a. retainer <input type="checkbox"/> b. one-time fee <input type="checkbox"/> c. commission <input type="checkbox"/> d. contingent fee <input type="checkbox"/> e. deferred <input type="checkbox"/> f. other, specify _____	
13. Form of Payment (check all that apply): <input checked="" type="checkbox"/> a. cash <input type="checkbox"/> b. in-kind; specify: nature _____ Value _____		
15. Brief Description of Services Performed or to be performed and Date(s) of Service, including officer(s), employee(s), or member(s) contacted, for Payment Indicated in Item 12: (attach Continuation Sheet(s) if necessary)		
16. Continuation Sheet(s) attached: Yes <input type="checkbox"/> No <input type="checkbox"/>		
17. Information requested through this form is authorized by Title 31 U.S.C. Section 1352. This disclosure of lobbying reliance was placed by the tier above when his transaction was made or entered into. This disclosure is required pursuant to 31 U.S.C. 1352. This information will be reported to Congress semiannually and will be available for public inspection. Any person who fails to file the required disclosure shall be subject to a civil penalty of not less than \$10,000 and not more than \$100,000 for each such failure.		
		Signature: _____ Print Name: <u>George A. Wentz</u> Title: <u>Vice President, Governmental Services</u> Telephone No.: <u>(951) 475-3601</u> Date: <u>09-18-2023</u>
Federal Use Only:		Authorized for Local Reproduction Standard Form - LLL

Standard Form LLL Rev. 04-28-06

Attachment: Agreement with HR Green Pacific (6330 : AUTHORIZATION TO AWARD AGREEMENTS FOR PROFESSIONAL CONSULTING





Appendix—Additions or Exceptions to the City’s Request for Proposal

Attachment: Agreement with HR Green Pacific (6330 : AUTHORIZATION TO AWARD AGREEMENTS FOR PROFESSIONAL CONSULTING

The sample contract provided contains language that should be modified or clarified to be more specific to the services being delivered. Based on our review, we believe revisions will provide greater clarity as to contractual obligations as well as compliance with state law requirements, which will benefit both parties. If selected, HR Green would like the opportunity to work with the City to develop the proposed agreement and address very specific issues. We would be prepared to discuss these matters immediately upon selection to assure that no time is lost and that the proposed work can be carried out in a timely manner.

As HR Green is currently under contract with the City, we are prepared to discuss these matters immediately upon selection and foresee a timely outcome.

For example:

Section 21(c)(iii) to be removed from the agreement as it has been removed from all previous agreements with Moreno Valley.

Special Provisions Exhibit, we would like to modify the Indemnification language as follows:

14. Indemnification.

a. Design Professional Services. To the fullest extent permitted by law, including but not limited to Civil Code Section 2782.8, in performing “design professional services” as defined in Section 2782.8, the Consultant agrees to indemnify, ~~defend,~~ and ^{hold} ~~save~~ the City, the Moreno Valley Community Services District (CSD), and the Moreno Valley Housing Authority (MVHA), their officers, ~~agents~~ and employees harmless from any and all liability, ~~claims,~~ ~~demands,~~ damages, or injuries to any person, including injury to the Consultant's employees and ^{costs to the extent caused by} ~~all claims which arise from or are connected with the~~ negligent, reckless, or willful misconduct in the performance of ~~or failure to perform the work or other obligations of the~~ Consultant under this RFP and/or related Agreement, or are caused ~~or claim to be caused by~~ the negligent acts of the Consultant, its officers, agents or employees, or its subconsultant(s) or any person acting for the Consultant or under its control or direction; provided, however, that this indemnification and hold harmless shall not include claims arising from the ~~sole~~ negligence, active negligence, or willful misconduct of the City, MVHA, and CSD, their officers, agents or employees; and does not apply to any passive negligence of City ~~unless caused at least in part by Consultant.~~



EXHIBIT "C"CITY - SERVICES TO BE PROVIDED
TO CONSULTANT

1. Furnish the Consultant all in-house data which is pertinent to services to be performed by the Consultant and which is within the custody or control of the City, including, but not limited to, copies of record and off-record maps and other record and off-record property data, right-of-way maps and other right-of-way data, pending or proposed subject property land division and development application data, all newly developed and pertinent design and WORK specification data, and such other pertinent data which may become available to the City.
2. Provide timely review, processing, and reasonably expeditious approval of all submittals by the Consultant.
3. Provide timely City staff liaison with the Consultant when requested and when reasonably needed.

EXHIBIT "D"

TERMS OF PAYMENT

1. The Consultant's compensation shall not exceed \$ **TBD** .
2. The Consultant will obtain, and keep current during the term of this Agreement, the required City of Moreno Valley business license. Proof of a current City of Moreno Valley business license will be required prior to any payments by the City. Any invoice not paid because the proof of a current City of Moreno Valley business license has not been provided will not incur any fees, late charges, or other penalties. Complete instructions for obtaining a City of Moreno Valley business license are located at: <http://www.moval.org/biz-lic>.
3. The Consultant will electronically submit an invoice to the City along with documentation evidencing services completed to date as specified in the Request for Proposal. Progress payments will be made in accordance with the payment schedule outlined in the Request for Proposal, but in no case will progress payments be made to the Consultant more frequently than once per month. The progress payment is based on actual time and materials expended in furnishing authorized professional services during the preceding calendar month. At no time will the City pay for more services than have been satisfactorily completed and the City Engineer's determination of the amount due for any progress payment shall be final. The consultant will submit all original invoices to Accounts Payable staff at TechInfo-CapProj@moval.org. Accounts Payable questions can be directed to (951) 413-3130.
4. The Consultant agrees that City payments will be received via Automated Clearing House (ACH) Direct Deposit and that the required ACH Authorization form will be

completed prior to any payments by the City. Any invoice not paid because the completed ACH Authorization Form has not been provided will not incur any fees, late charges, or other penalties. The ACH Authorization Form is located at:

http://www.moval.org/city_hall/forms.shtml#bf

5. The minimum information required on all invoices is:
 - A. Vendor Name, Mailing Address, and Phone Number
 - B. Invoice Date
 - C. Vendor Invoice Number
 - D. City-provided Reference Number (e.g. WORK, Activity)
 - E. Detailed work hours by class title (e.g. Manager, Technician, or Specialist), services performed and rates, explicit portion of a contract amount, or detailed billing information that is sufficient to justify the invoice amount; single, lump amounts without detail are not acceptable.
6. The City shall pay the Consultant for all invoiced, authorized professional services within thirty (30) days of receipt of the invoice for same.



Professional Consultant Senior Engineer Services

COST PROPOSAL FOR
City of Moreno Valley

SEPTEMBER 18, 2023



Attachment: Agreement with HR Green Pacific (6330 : AUTHORIZATION TO AWARD AGREEMENTS FOR PROFESSIONAL CONSULTING

Steve Loriso, PE, QSD/QSP

1260 Corona Pointe Court, Suite 305
Corona, CA 92879-5013

Direct 951.475.3619 + Mobile 909.630.2577

sloriso@hrgreen.com

4.6 Cost Proposal

Our hourly fees/rates shall remain effective through December 31, 2024 and may be adjusted annually thereafter as negotiated with and agreed to by the agency. Our anticipated escalation rate per year will be based on an increase of the region's Consumer Price Index (CPI) but not to exceed 4%.

Personnel Classification	Hourly Billing Rate
Client Services Manager	\$240
Senior Engineer	\$200
Assistant Engineer	\$130
Engineering Technician	\$125

The table below shows an anticipated staff/resource allocation for projects (%). The hours provided represent an estimate for a typical street rehabilitation project with an approximate total budget of \$500,000; hours are based on our past experience delivering projects of this value and complexity and are intended to be a basis of negotiation with the City.

TASK	Client Services Manager		Senior Engineer		Assistant Engineer		Engineering Technician	
	%	Hours	%	Hours	%	Hours	%	Hours
Client coordination	100%	4	0					
Project Understanding and Project Controls	2%	1	80%	40	10%	5	8%	4
Project Planning, Re-sourcing & Initiation Phase	2%	1	60%	30	30%	15	8%	4
Project Design Management	2%	1	73%	37	30%	15	0%	0
Bid / Construction Support	2%	1	50%	25	40%	20	8%	4
Construction Management and Inspection	2%	7	68%	255	20%	116	10%	60

Notes:

1. Other classifications are available based upon the needs of the agency.
2. All general engineering tasks will be negotiated on a case by case basis using the hourly rates provided for personnel assigned to the contract.

Attachment: Agreement with HR Green Pacific (6330 : AUTHORIZATION TO AWARD AGREEMENTS FOR PROFESSIONAL CONSULTING



Professional Reimbursement / Hourly and Overtime Rates:

The hourly billing rates include the cost of salaries of the HR Green employees, plus sick leave, vacation, holiday and other fringe benefits. The percentage added to salary costs includes indirect overhead costs and fee (profit). All employees classified as “non-exempt” by the U.S. Department of Labor will be compensated at 1.5 times salary, as per state and Federal wage and hour for overtime hours. Billing rates will be calculated accordingly for overtime hours.

Direct/Reimbursable Expenses and Subconsultants:

Reimbursement for direct expenses, as listed below, incurred in connection with the work, will be at cost plus 10% for items such as:

- a. Maps, photographs, reproductions, printing, equipment rental and special supplies related to the work.
- b. Subconsultants and other outside services, if needed.
- c. Specific telecommunications and delivery charges.
- d. Special fees, insurance, permits, and licenses applicable to the work.
- e. Outside computer processing, computation, and proprietary programs purchased for the work.
- f. Mileage and vehicle costs directly related to agency services.
- g. Travel expenses (e.g., hotel, meals, transportation, etc.).



EXHIBIT "E"

INSURANCE REQUIREMENTS

Minimum Scope of Insurance

Coverage shall be at least as broad as:

1. The most current version of Insurance Services Office (ISO) Commercial General Liability Coverage Form CG 00 01, which shall include insurance for "bodily injury," "property damage" and "personal and advertising injury" with coverage for premises and operations, products and completed operations, and contractual liability.
2. The most current version of Insurance Service Office (ISO) Business Auto Coverage Form CA 00 01, which shall include coverage for all owned, hired, and non-owned automobiles or other licensed vehicles (Code 1- Any Auto).
3. Workers' Compensation insurance as required by the California Labor Code and Employer's Liability Insurance.
4. Professional Liability (Errors and Omissions) insurance appropriate to Consultant's profession.

Minimum Limits of Insurance

Consultant shall maintain limits of liability of not less than:

1. General Liability:
 - \$1,000,000 per occurrence for bodily injury and property damage
 - \$1,000,000 per occurrence for personal and advertising injury
 - \$2,000,000 aggregate for products and completed operations
 - \$2,000,000 general aggregate
2. Automobile Liability:
 - \$1,000,000 per accident for bodily injury and property damage
3. Employer's Liability:
 - \$1,000,000 each accident for bodily injury
 - \$1,000,000 disease each employee
 - \$1,000,000 disease policy limit

Attachment: Agreement with HR Green Pacific (6330 : AUTHORIZATION TO AWARD AGREEMENTS FOR PROFESSIONAL CONSULTING

4. Professional Liability (Errors and Omissions):

\$1,000,000 per claim/occurrence
\$2,000,000 policy aggregate

Umbrella or Excess Insurance

In the event Consultant purchases an Umbrella or Excess insurance policy(ies) to meet the "Minimum Limits of Insurance," this insurance policy(ies) shall "follow form" and afford no less coverage than the primary insurance policy(ies).

Deductibles and Self-Insured Retentions

Consultant shall be responsible for payment of any deductibles contained in any insurance policy(ies) required hereunder and Consultant shall also be responsible for payment of any self-insured retentions. Any deductibles or self-insured retentions must be declared to, and approved by, the City Manager or his/her designee. At the option of the City Manager or his/her designee, either (i) the insurer shall reduce or eliminate such deductibles or self-insured retentions as respects The City of Moreno Valley, the City of Moreno Valley Community Services District, the Moreno Valley Housing Authority, and each of their officers, officials, employees, agents and volunteers; or (ii) Consultant shall provide a financial guarantee, satisfactory to the City Manager or his/her designee, guaranteeing payment of losses and related investigations, claim administration and defense expenses. At no time shall City be responsible for the payment of any deductibles or self-insured retentions.

Other Insurance Provisions

The General Liability and Automobile Liability insurance policies are to contain, or be endorsed to contain, the following provisions:

1. The City of Moreno Valley, the City of Moreno Valley Community Services District, the Moreno Valley Housing Authority, and each of their officers, officials, employees, agents and volunteers are to be covered as additional insureds.
2. The coverage shall contain no special limitations on the scope of protection afforded to the City of Moreno Valley, the City of Moreno Valley Community Services District, the Moreno Valley Housing Authority, and each of their officers, officials, employees, agents and volunteers.
3. Consultant's insurance coverage shall be primary and no contribution shall be required of City.

The Workers' Compensation insurance policy is to contain, or be endorsed to contain, the following provision: Consultant and its insurer shall waive any right of subrogation against the City of Moreno Valley, the City of Moreno Valley Community Services District, the Moreno Valley Housing Authority, and each of their officers, officials, employees, agents and volunteers.

If the Professional Liability (Errors and Omissions) insurance policy is written on a claims-made

form:

1. The retroactive date must be shown, and must be before the effective date of the Agreement or the commencement of work by Consultant.
2. Insurance must be maintained and evidence of insurance must be provided for at least 3 years after any expiration or termination of the Agreement or, in the alternative, the policy shall be endorsed to provide not less than a 3-year discovery period.
3. If coverage is canceled or non-renewed, and not replaced with another claims-made policy form with a retroactive date prior to the effective date of the Agreement or the commencement of work by Consultant, Consultant must purchase extended reporting coverage for a minimum of 3 years following the expiration or termination of the Agreement.
4. A copy of the claims reporting requirements must be submitted to City for review.
5. These requirements shall survive expiration or termination of the Agreement.

All policies of insurance required hereunder shall be endorsed to provide that the coverage shall not be cancelled, non-renewed, reduced in coverage or in limits except after 30 calendar day written notice by certified mail, return receipt requested, has been given to City. Upon issuance by the insurer, broker, or agent of a notice of cancellation, non-renewal, or reduction in coverage or in limits, Consultant shall furnish City with a new certificate and applicable endorsements for such policy(ies). In the event any policy is due to expire during the work to be performed for City, Consultant shall provide a new certificate, and applicable endorsements, evidencing renewal of such policy not less than 15 calendar days prior to the expiration date of the expiring policy.

Acceptability of Insurers

All policies of insurance required hereunder shall be placed with an insurance company(ies) admitted by the California Insurance Commissioner to do business in the State of California and rated not less than "A-VII" in Best's Insurance Rating Guide; or authorized by the City Manager or his/her designee.

Verification of Coverage

Consultant shall furnish City with all certificate(s) and **applicable endorsements** effecting coverage required hereunder. All certificates and **applicable endorsements** are to be received and approved by the City Manager or his/her designee prior to City's execution of the Agreement and before work commences.

**AGREEMENT FOR
PROFESSIONAL CONSULTANT SENIOR ENGINEER AND
RELATED ADMINISTRATIVE SERVICES FOR CAPITAL PROJECTS DIVISION**

This Agreement (hereinafter, this “Agreement”) is made and entered into this ____ day of _____ 2023 (“Effective Date”), by and between the City of Moreno Valley, a municipal corporation in the County of Riverside, State of California, hereinafter referred to as the “City,” and **CWE**, (California corporation, partnership, sole ownership), hereinafter referred to as “Consultant.”

RECITALS

WHEREAS, the City has determined it is in the public interest to proceed with the professional consultant senior engineer and administrative services hereinafter described as "WORK"; and

WHEREAS, the City has determined the WORK involves the performance of professional and technical services of a temporary nature as more specifically described in Exhibit "A" (City's Request for Proposal) and Exhibit "B" (Consultant's Proposal) hereto; and

WHEREAS, the City does not have available employees to perform the services for the WORK; and

WHEREAS, the City has requested the Consultant to perform such services for the WORK; and

WHEREAS, the Consultant is professionally qualified in California to perform the professional and technical services required for the WORK, and hereby represents that it desires to and is professionally and legally capable of performing the services called for by this Agreement;

THEREFORE, the City and the Consultant, for the consideration hereinafter described, mutually agree as follows:

Attachment: Agreement with CWE (6330 : AUTHORIZATION TO AWARD AGREEMENTS FOR PROFESSIONAL CONSULTING SENIOR

**AGREEMENT FOR PROFESSIONAL CONSULTANT
SENIOR ENGINEER AND ADMINISTRATIVE SERVICES**

DESCRIPTION OF WORK

1. The WORK is described as Professional Consultant Senior Engineer and Administrative Services.

SCOPE OF SERVICES

2. The Consultant's scope of service is described on Exhibit "B" attached hereto and incorporated herein by this reference. In the event of a conflict, the City's Request for Proposal shall take precedence over the Consultant's Proposal.

3. The City's responsibility is described on Exhibit "C" attached hereto and incorporated herein by this reference.

PAYMENT TERMS

4. The City agrees to pay the Consultant and the Consultant agrees to receive a "Not-to-Exceed" fee of \$ TBD in accordance with the payment terms provided on Exhibit "D" attached hereto and incorporated herein by this reference.

TIME FOR PERFORMANCE

5. The Consultant shall commence services upon receipt of written direction to proceed from the City.

6. The Consultant shall perform the work described on Exhibit "A" in accordance with the schedule set forth in Exhibit "B" attached hereto and incorporated by this reference.

7. This Agreement shall be effective from effective date and shall continue in full force and effect date through December 30, 2026, subject to any earlier termination in accordance with this Agreement. The services of Consultant shall be completed in a sequence assuring expeditious completion, but in any event, all such services shall be completed prior to expiration of this Agreement.

8. (a) The Consultant agrees that the personnel, including the principal WORK

**AGREEMENT FOR PROFESSIONAL CONSULTANT
SENIOR ENGINEER AND ADMINISTRATIVE SERVICES**

Manager, and all subconsultants assigned to the WORK by the Consultant, shall be subject to the prior approval of the City.

(b) No change in subconsultants or key personnel shall be made by the Consultant without written prior approval of the City.

SPECIAL PROVISIONS

9. It is understood and agreed that the Consultant is, and at all times shall be, an independent consultant and nothing contained herein shall be construed as making the Consultant or any individual whose compensation for services is paid by the Consultant, an agent or employee of the City, or authorizing the Consultant to create or assume any obligation or liability for or on behalf of the City.

10. The Consultant may also retain or subcontract for the services of other necessary consultants with the prior written approval of the City. Payment for such services shall be the responsibility of the Consultant. Any and all subconsultants employed by the Consultant shall be subject to the terms and conditions of this Agreement, except that the City shall have no obligation to pay any subconsultant for services rendered on the WORK.

11. The Consultant and the City agree to use reasonable care and diligence to perform their respective services under this Agreement.

12. The Consultant shall comply with applicable federal, state, and local laws in the performance of work under this Agreement.

13. To the extent required by controlling federal, state and local law, Consultant shall not employ discriminatory practices in the provision of services, employment of personnel, or in any other respect on the basis of race, religious creed, color, national origin, ancestry, physical disability, mental disability, medical condition, marital status, sex, age, sexual orientation, ethnicity, status as a disabled veteran or veteran of the Vietnam era. Subject to the foregoing

**AGREEMENT FOR PROFESSIONAL CONSULTANT
SENIOR ENGINEER AND ADMINISTRATIVE SERVICES**

and during the performance of this Agreement, Consultant agrees as follows:

(a) Consultant will comply with all applicable laws and regulations providing that no person shall, on the grounds of race, religious creed, color, national origin, ancestry, physical disability, mental disability, medical condition, marital status, sex, age, sexual orientation, ethnicity, status as a disabled veteran or veteran of the Vietnam era be excluded from participation in, be denied the benefits of, or be subject to discrimination under any program or activity made possible by or resulting from this Agreement.

(b) Consultant will not discriminate against any employee or applicant for employment because of race, religious creed, color, national origin, ancestry, physical disability, mental disability, medical condition, marital status, sex, age, sexual orientation, ethnicity, status as a disabled veteran or veteran of the Vietnam era. Consultant shall ensure that applicants are employed, and the employees are treated during employment, without regard to their race, religious creed, color, national origin, ancestry, physical disability, mental disability, medical condition, marital status, sex, age, sexual orientation, ethnicity, status as a disabled veteran or veteran of the Vietnam era. Such requirements shall apply to Consultant's employment practices including, but not be limited to, the following: employment, upgrading, demotion or transfer; recruitment or recruitment advertising; layoff or termination; rates of pay or other forms of compensation; and selection for training, including apprenticeship. Consultant agrees to post in conspicuous places, available to employees and applicants for employment, notices setting forth the provision of this nondiscrimination clause.

(c) Consultant will, in all solicitations or advertisements for employees placed by or on behalf of Consultant in pursuit hereof, state that all qualified applicants will receive consideration for employment without regard to race, religious creed, color, national origin, ancestry, physical disability, mental disability, medical condition, marital status, sex, age, sexual

**AGREEMENT FOR PROFESSIONAL CONSULTANT
SENIOR ENGINEER AND ADMINISTRATIVE SERVICES**

orientation, ethnicity, status as a disabled veteran or veteran of the Vietnam era.

(d) If Consultant should subcontract all or any portion of the services to be performed under this Agreement, Consultant shall cause each subconsultant to also comply with the requirements of this Section 13.

14. Indemnification.

a. Design Professional Services. To the fullest extent permitted by law, including but not limited to Civil Code Section 2782.8, in performing “design professional services” as defined in Section 2782.8, the Consultant agrees to indemnify, defend, and save the City, the Moreno Valley Community Services District (CSD), and the Moreno Valley Housing Authority (MVHA), their officers, agents and employees harmless from any and all liability, claims, demands, damages, or injuries to any person, including injury to the Consultant's employees and all claims which arise from or are connected with the negligent, reckless, or willful misconduct in the performance of or failure to perform the work or other obligations of the Consultant under this RFP and/or related Agreement, or are caused or claim to be caused by the negligent acts of the Consultant, its officers, agents or employees, or its subconsultant(s) or any person acting for the Consultant or under its control or direction; provided, however, that this indemnification and hold harmless shall not include claims arising from the sole negligence, active negligence, or willful misconduct of the City, MVHA, and CSD, their officers, agents or employees; and does not apply to any passive negligence of City unless caused at least in part by Consultant.

b. Non-Design Professional Services. For all non-design professional services, Consultant shall indemnify, defend, and save the City, the Moreno Valley Community Services District (CSD), and the Moreno Valley Housing Authority (MVHA), their officers, agents and employees harmless from any and all liability, claims, demands, damages, or injuries to any

**AGREEMENT FOR PROFESSIONAL CONSULTANT
SENIOR ENGINEER AND ADMINISTRATIVE SERVICES**

person, including injury to the Consultant's employees and all claims which arise from or are connected with the performance of or failure to perform the work or other obligations of the Consultant, or are caused or claim to be caused by the acts of the Consultant, its officers, agents or employees, or its subconsultant(s) or any person acting for the Consultant or under its control or direction; provided, however, that this indemnification and hold harmless shall not include claims arising from the sole negligence or willful misconduct of the City, MVHA, and CSD, their officers, agents or employees.

c. If Consultant should subcontract all or any portion of the services to be performed under this Agreement, Consultant shall require each subconsultant to indemnify, hold harmless and defend City, CSD, Housing Authority and each of their officers, officials, employees, agents and volunteers in accordance with the terms of the preceding paragraph.

d. CalPERS Indemnity. To the fullest extent permitted by law, in addition to obligations set forth in this section, in the event that any person providing services under this Agreement is determined by a court of competent jurisdiction or CalPERS to be eligible for enrollment in CalPERS as an employee of the City, to the fullest extent of the law, Consultant shall indemnify, defend, and hold harmless City for any costs and expenses incurred by City, including without limitation, payment that City is required as a result to make to CalPERS, whether in the form of employee and/or employer contributions, taxes, or any similar obligations, as well as for the payment of any penalties and interest.

15. CalPERS Participation. As set forth in this Agreement and in the Request for Qualifications, City has an obligation to treat all persons working for or under the direction of Consultant as an independent Consultant of City and agents and employees of Consultant, and not as agents or employees of City. Consultant and City acknowledge and agree that City participates in a defined benefit plan ("CalPERS"), and that it is possible that CalPERS may find

**AGREEMENT FOR PROFESSIONAL CONSULTANT
SENIOR ENGINEER AND ADMINISTRATIVE SERVICES**

that persons providing services pursuant to this Agreement are employees of City and should be registered with the CalPERS as employees of City.

16. CalPERS Retiree Disclosure. Consultant hereby expressly agrees to clearly and conspicuously disclose to City in writing any and all persons working for Consultant who are retirees under the California Public Employees' Retirement System (CalPERS) whom receives a monthly CalPERS retirement allowance, and whom are, subject to City approval, assigned by Consultant to provide services to City under the Agreement, prior to such person performing any services hereunder. Nothing herein shall be deemed or interpreted to limit a CalPERS retiree's obligations under applicable law, rules or regulations.

Joint Cooperation. In the event that CalPERS initiates an inquiry that includes examination of whether individuals providing services under this Agreement to City are City's employees, Consultant shall within five days and share all communications and documents from CalPERS that it may legally share. In the event that either Consultant or City files an appeal or court challenge, Consultant and City each agree to cooperate with each other in responding to the inquiry and any subsequent administrative appeal or court challenge of an adverse determination.

This section shall survive termination or expiration of this Agreement.

17. Insurance.

(a) Throughout the life of this Agreement, Consultant shall pay for and maintain in full force and effect all insurance as required in **Exhibit E** or as may be authorized in writing by the City Manager or his/her designee at any time and in his/her sole discretion.

(b) If at any time during the life of the Agreement or any extension, Consultant or any of its subconsultant fail to maintain any required insurance in full force and effect, all services and work under this Agreement shall be discontinued immediately, and all payments

**AGREEMENT FOR PROFESSIONAL CONSULTANT
SENIOR ENGINEER AND ADMINISTRATIVE SERVICES**

due or that become due to Consultant shall be withheld until notice is received by City that the required insurance has been restored to full force and effect and that the premiums therefore have been paid for a period satisfactory to City. Any failure to maintain the required insurance shall be sufficient cause for City to terminate this Agreement. No action taken by City pursuant to this section shall in any way relieve Consultant of its responsibilities under this Agreement. The phrase "fail to maintain any required insurance" shall include, without limitation, notification received by City that an insurer has commenced proceedings, or has had proceedings commenced against it, indicating that the insurer is insolvent.

(c) The fact that insurance is obtained by Consultant shall not be deemed to release or diminish the liability of Consultant, including, without limitation, liability under the indemnity provisions of this Agreement. The duty to indemnify City shall apply to all claims and liability regardless of whether any insurance policies are applicable. The policy limits do not act as a limitation upon the amount of indemnification to be provided by Consultant. Approval or purchase of any insurance contracts or policies shall in no way relieve from liability nor limit the liability of Consultant, its principals, officers, agents, employees, persons under the supervision of Consultant, vendors, suppliers, invitees, consultants, sub-consultants, subconsultants or anyone employed directly or indirectly by any of them.

(d) Upon request of City, Consultant shall immediately furnish City with a complete copy of any insurance policy required under this Agreement, including all endorsements, with said copy certified by the underwriter to be a true and correct copy of the original policy. This requirement shall survive expiration or termination of this Agreement.

(e) If Consultant should subcontract all or any portion of the services to be performed under this Agreement, Consultant shall require each subconsultant to provide insurance protection in favor of City and each of its officers, officials, employees, agents and

**AGREEMENT FOR PROFESSIONAL CONSULTANT
SENIOR ENGINEER AND ADMINISTRATIVE SERVICES**

volunteers in accordance with the terms of this section, except that any required certificates and applicable endorsements shall be on file with Consultant and City prior to the commencement of any services by the subconsultant.

18. The waiver by either party of a breach by the other of any provision of this Agreement shall not constitute a continuing waiver or a waiver of any subsequent breach of either the same or a different provision of this Agreement. No provisions of this Agreement may be waived unless in writing and signed by all parties to this Agreement. Waiver of any one provision herein shall not be deemed to be a waiver of any other provision herein.

19. Consultant and subconsultants shall pay prevailing wage rates when required by the Labor Laws of the State of California. Consultant and all of Consultant's subcontractors, if any, shall pay each employee engaged in all applicable trades or occupation not less than the prevailing hourly wage rate for work of a similar character in the locality in which the public work is performed, and not less than the general prevailing rate of per diem wages for holiday and overtime work. In accordance with the provisions of Section 1770 of the California Labor Code ("Labor Code"), the Director of Department of Industrial Relations of the State of California has determined the general prevailing rates of wages and employer payments for health and welfare, pension, vacation, travel time, and subsistence pay as provided for in Labor Code Section 1773.8, apprenticeship or other training programs authorized by Labor Code Section 3093 and similar purposes applicable to the work to be done. Said wages are available through the California Department of Industrial Relations' Internet website at <http://www.dir.ca.gov/dlsr/PWD/index.htm> and are on file at City Hall, as provided in Section 1773.2 of the Labor Code. Said rates shall be posted at the WORK site where work is to be performed, in accordance with Labor Code Section 1773.2. Consultant shall access a copy of the wage rate determination and shall make all subcontractors, if any, aware of the

**AGREEMENT FOR PROFESSIONAL CONSULTANT
SENIOR ENGINEER AND ADMINISTRATIVE SERVICES**

determination. As the wage determination for each craft reflects an expiration date, it shall be the Consultant's responsibility to ensure that the prevailing wage rates of concern are current and paid. Subject to the safe harbor provisions of Labor Code Section 1775, Consultant shall forfeit to the City an amount not to exceed two hundred dollars (\$200) for each calendar day or portion thereof, as set by the Labor Commissioner in accordance with the terms of Labor Code section 1775, for each laborer, workmen or mechanics employed that is paid less than the general prevailing rate of wages herein referred to and stipulated for any work done under the proposed contract, by him, or by any subcontractor under him, in violation of the provisions of the Labor Code, and in particular, Sections 1770 to 1781 inclusive. Consultant and any and all or its subcontractors shall forfeit to the City twenty-five dollars (\$25) for each worker employed in the performance of this Agreement for each calendar day during which the worker is required or permitted to work more than eight (8) hours in any one calendar day and forty (40) hours in any one calendar week in violation of the provisions of Section 1813 of the Labor Code. In the event the total cost of the WORK is thirty thousand dollars (\$30,000.00) or more, Consultant shall further comply with provisions set forth in Labor Code Section 1777.5 pertaining to employment of properly registered apprentices, including without limitation the obligation to (i) pay employed apprentices the prevailing rate of per diem wages for apprentices in the trade to which he or she is registered and shall be employed only at the work of craft or trade to which he or she is registered; (ii) employ apprentices in at least the ratio as set forth in said section; (iii) submit contract award information to an applicable apprenticeship program; and (iv) contribute to California Apprenticeship Council.

Consultant and all subcontractors hired to perform any work under the WORK shall keep accurate payroll records, including the name, address, social security number, work classification, straight time and overtime hours worked each day and week, and the actual per

**AGREEMENT FOR PROFESSIONAL CONSULTANT
SENIOR ENGINEER AND ADMINISTRATIVE SERVICES**

diem wages paid to each worker, in accordance with Section 1776 of the Labor Code. Payroll records shall be on forms provided by the Division of Labor Standards Enforcement (“DLSE”) or in a manner containing the same information as the forms provided by the DLSE. Failure to comply with the above may result in monetary penalties to the Consultant or affected subcontractor. Payroll records shall be verified by written declaration made under penalty of perjury, that the information contained in the records is true and correct. Consultant and any and all subcontractors shall make a certified copy of all payroll records available for inspection by DLSE, the City or any member of the public and otherwise provide certified copies of such records to any of the foregoing within ten (10) days of Consultant’s and subcontractor’s receipt of written request therefor. Failure to comply with the above may result in monetary penalties, in accordance with Labor Code Section 1776(d) and (h).

Notwithstanding anything else to the contrary, Consultant hereby acknowledges that all contractors and subcontractors must be registered with the Department of Industrial Relations (“Department”) pursuant to Labor Code Section 1725.5 in order to be qualified to bid on, be listed in a bid proposal, subject to the requirements of Section 4104 of the Public Contract Code, or engage in the performance of any public work contract, including this Agreement, that is subject to the payment of prevailing wages. The WORK is subject to compliance monitoring and enforcement by the Department of Industrial Relations. In accordance with Section 3700 of the Labor Code, Consultant must secure payment of compensation to all Consultant’s employees. Consultant represents and warrants that Consultant is registered with the Department in the manner prescribed by the Department and has paid the requisite application fee, as required by Labor Code Section 1725.5. Moreover, prior to Consultant entering into any contracts with any subcontractor, Consultant shall obtain proof that all such subcontractors have also registered with the Department in accordance with Section 1725.5.

**AGREEMENT FOR PROFESSIONAL CONSULTANT
SENIOR ENGINEER AND ADMINISTRATIVE SERVICES**

20. (a) The Consultant shall deliver to the [Public Works Director/City Engineer or his/her designated representative](#), fully completed and detailed WORK-related documents which shall become the property of the City. The Consultant may retain, for its files, copies of any and all material, including drawings, documents, and specifications, produced by the Consultant in performance of this Agreement.

(b) The Consultant shall be entitled to copies of all furnished materials for his files and his subconsultants, if any.

(c) The City agrees to hold the Consultant free and harmless from any claim arising from any unauthorized use of computations, maps, and other documents prepared or provided by the Consultant under this Agreement, if used by the City on other work without the permission of the Consultant. Consultant acknowledges that Consultant work product produced under this agreement may be public record under State law.

21. (a) This Agreement shall terminate without any liability of City to Consultant upon the earlier of: (i) Consultant's filing for protection under the federal bankruptcy laws, or any bankruptcy petition or petition for receiver commenced by a third party against Consultant; (ii) 10 calendar days prior written notice with or without cause by City to Consultant; (iii) City's non-appropriation of funds sufficient to meet its obligations hereunder during any City fiscal year of this Agreement, or insufficient funding for the WORK; or (iv) expiration of this Agreement. The written notice shall specify the date of termination. Upon receipt of such notice, the Consultant may continue services on the WORK through the date of termination, provided that no service(s) shall be commenced or continued after receipt of the notice, which is not intended to protect the interest of the City. The City shall pay the Consultant within thirty (30) days after the date of termination for all non-objected to services performed by the Consultant in accordance herewith

**AGREEMENT FOR PROFESSIONAL CONSULTANT
SENIOR ENGINEER AND ADMINISTRATIVE SERVICES**

through the date of termination. Consultant shall not be paid for any work or services performed or costs incurred which reasonably could have been avoided.

(b) In the event of termination due to failure of Consultant to satisfactorily perform in accordance with the terms of this Agreement, City may withhold an amount that would otherwise be payable as an offset to, but not in excess of, City's damages caused by such failure. In no event shall any payment by City pursuant to this Agreement constitute a waiver by City of any breach of this Agreement which may then exist on the part of Consultant, nor shall such payment impair or prejudice any remedy available to City with respect to the breach.

(c) Upon any breach of this Agreement by Consultant, City may (i) exercise any right, remedy (in contract, law or equity), or privilege which may be available to it under applicable laws of the State of California or any other applicable law; (ii) proceed by appropriate court action to enforce the terms of the Agreement; and/or (iii) recover all direct, indirect, consequential, economic and incidental damages for the breach of the Agreement. If it is determined that City improperly terminated this Agreement for default, such termination shall be deemed a termination for convenience.

(d) Consultant shall be liable for default unless nonperformance is caused by an occurrence beyond the reasonable control of Consultant and without its fault or negligence such as, acts of God or the public enemy, acts of City in its contractual capacity, fires, floods, epidemics, quarantine restrictions, strikes, unusually severe weather, and delays of common carriers. Consultant shall notify City in writing as soon as it is reasonably possible after the commencement of any excusable delay, setting forth the full particulars in connection therewith, and shall remedy such occurrence with all reasonable dispatch, and shall promptly give written notice to Administrator of the cessation of such occurrence.

22. This Agreement is binding upon the City and the Consultant and their successors

**AGREEMENT FOR PROFESSIONAL CONSULTANT
SENIOR ENGINEER AND ADMINISTRATIVE SERVICES**

and assigns. Except as otherwise provided herein, neither the City nor the Consultant shall assign, sublet, or transfer its interest in this Agreement or any part thereof without the prior written consent of the other.

23. A City representative shall be designated by the City and a Consultant representative shall be designated by the Consultant. The City representative and the Consultant representative shall be the primary contact person for each party regarding performance of this Agreement. The City representative shall cooperate with the Consultant, and the Consultant's representative shall cooperate with the City in all matters regarding this Agreement and in such a manner as will result in the performance of the services in a timely and expeditious fashion.

24. This Agreement represents the entire and integrated Agreement between the City and the Consultant, and supersedes all prior negotiations, representations or Agreements, either written or oral. This Agreement may be modified or amended only by a subsequent written Agreement signed by both parties.

25. Where the payment terms provide for compensation on a time and materials basis, the Consultant shall maintain adequate records to permit inspection and audit of the Consultant's time and materials charges under this Agreement. The Consultant shall make such records available to the City at the Consultant's office during normal business hours upon reasonable notice. Nothing herein shall convert such records into public records. Except as may be otherwise required by law, such records will be available only to the City. Such records shall be maintained by the Consultant for three (3) years following completion of the services under this Agreement.

26. The City and the Consultant agree, that to the extent permitted by law, until final approval by the City, all data shall be treated as confidential and will not be released to third

**AGREEMENT FOR PROFESSIONAL CONSULTANT
SENIOR ENGINEER AND ADMINISTRATIVE SERVICES**

parties without the prior written consent of both parties.

27. (a) Consultant shall comply, and require its subconsultants to comply, with all applicable (i) professional canons and requirements governing avoidance of impermissible client conflicts; and (ii) federal, state and local conflict of interest laws and regulations including, without limitation, California Government Code Section 1090 et. seq., the California Political Reform Act (California Government Code Section 87100 et. seq.) and the regulations of the Fair Political Practices Commission concerning disclosure and disqualification (2 California Code of Regulations Section 18700 et. seq.). At any time, upon written request of City, Consultant shall provide a written opinion of its legal counsel and that of any subconsultant that, after a due diligent inquiry, Consultant and the respective subconsultant(s) are in full compliance with all laws and regulations. Consultant shall take, and require its subconsultants to take, reasonable steps to avoid any appearance of a conflict of interest. Upon discovery of any facts giving rise to the appearance of a conflict of interest, Consultant shall immediately notify City of these facts in writing.

(b) In performing the work or services to be provided hereunder, Consultant shall not employ or retain the services of any person while such person either is employed by City or is a member of any City council, commission, board, committee, or similar City body. This requirement may be waived in writing by the City Manager, if no actual or potential conflict is involved.

(c) Consultant represents and warrants that it has not paid or agreed to pay any compensation, contingent or otherwise, direct or indirect, to solicit or procure this Agreement or any rights/benefits hereunder.

(d) Neither Consultant, nor any of Consultant's subconsultants performing any services on this WORK, shall bid for, assist anyone in the preparation of a bid for, or perform

**AGREEMENT FOR PROFESSIONAL CONSULTANT
SENIOR ENGINEER AND ADMINISTRATIVE SERVICES**

any services pursuant to, any other contract in connection with this WORK unless fully disclosed to and approved by the City Manager, in advance and in writing. Consultant and any of its subconsultants shall have no interest, direct or indirect, in any other contract with a third party in connection with this WORK unless such interest is in accordance with all applicable law and fully disclosed to and approved by the City Manager, in advance and in writing. Notwithstanding any approval given by the City Manager under this provision, Consultant shall remain responsible for complying with Section 25(a), above.

(e) If Consultant should subcontract all or any portion of the work to be performed or services to be provided under this Agreement, Consultant shall include the provisions of this Section 25 in each subcontract and require its subconsultants to comply therewith.

(f) This Section 25 shall survive expiration or termination of this Agreement.

28. All Plans, drawings, Specifications, reports, logs, and other documents prepared by the Consultant in its performance under this Agreement shall, upon completion of the WORK, be delivered to and be the property of the City, provided that the Consultant shall be entitled, at its own expense, to make copies thereof for its own use.

29. The laws of the State of California shall govern the rights, obligations, duties, and liabilities of the parties to this Agreement, and shall also govern the interpretation of this Agreement. Venue shall be vested in the Superior Court of the State of California, County of Riverside.

30. Consultant expressly waives any and all rights and benefits conferred upon it by the provisions of Section 1542 of the California Civil Code which reads as follows:

“A general release does not extend to claims that the creditor or releasing party does not know or suspect to exist in his or her favor at the time of

**AGREEMENT FOR PROFESSIONAL CONSULTANT
SENIOR ENGINEER AND ADMINISTRATIVE SERVICES**

executing the release and that, if known by him or her, would have materially affected his or her settlement with the debtor or released party.”

Initials

This waiver shall be effective as a bar to any and all actions, fees, damages, losses, claims, liabilities and demands of whatsoever character, nature and kind that are known or unknown, or suspected or unsuspected, including, without limitation, claims of entitlements under the California Public Employees’ Retirement System (CalPERS) that are only afforded to employees and not independent contractors. Consultant further represents and warrants that it understands this waiver and that if it does not understand this waiver, it shall seek the advice of a qualified attorney before executing this Agreement.

Consultant hereby expressly agrees to clearly and conspicuously disclose to City in writing any and all persons working for Consultant who are retirees under the California Public Employees’ Retirement System (CalPERS) whom receives a monthly CalPERS retirement allowance, which may provide services to City under the Agreement, prior to such person performing any services thereunder. Nothing herein shall be deemed or interpreted to limited a CalPERS retiree’s obligations under applicable law, rules or regulations.

SIGNATURE PAGE FOLLOWS

Attachment: Agreement with CWE (6330 : AUTHORIZATION TO AWARD AGREEMENTS FOR PROFESSIONAL CONSULTING SENIOR

IN WITNESS HEREOF, the parties have each caused their authorized representative to execute this Agreement.

City of Moreno Valley

CWE

BY: _____
Mike Lee, City Manager

Date

BY: _____

Name: _____

TITLE: _____
(President or Vice President)

Date

BY: _____

Name: _____

TITLE: _____
(Corporate Secretary)

Date

<u>INTERNAL USE ONLY</u>
APPROVED AS TO LEGAL FORM:

City Attorney

Date
RECOMMENDED FOR APPROVAL:

Public Works Director/City Engineer

Date

- Enclosures:
- Exhibit "A" – City Scope of Services
 - Exhibit "B" – Consultant Proposal
 - Exhibit "C" – City Services
 - Exhibit "D" – Terms of Payment
 - Exhibit "E" – Insurance Requirements

Attachment: Agreement with CWE (6330 : AUTHORIZATION TO AWARD AGREEMENTS FOR PROFESSIONAL CONSULTING SENIOR

EXHIBIT "A"

REQUEST FOR PROPOSAL

2023-020

PROFESSIONAL CONSULTANT SENIOR ENGINEER SERVICES

City of Moreno Valley
14177 Frederick St.
Moreno Valley, CA 92552



RELEASE DATE: August 28, 2023

DEADLINE FOR QUESTIONS: September 11, 2023

RESPONSE DEADLINE: September 18, 2023, 2:00 pm

RESPONSES MUST BE SUBMITTED ELECTRONICALLY TO:

<https://secure.procurenow.com/portal/morenovalley>

City of Moreno Valley
REQUEST FOR PROPOSAL

Professional Consultant Senior Engineer Services

- 1. NOTICE TO BIDDERS.....
- 2. SCOPE OF SERVICES
- 3. GENERAL INFORMATION
- 4. PROPOSAL CONTENT
- 5. PROSPECTIVE BIDDER QUALIFICATIONS.....
- 6. SUBMISSION OF PROPOSALS
- 7. EVALUATION AND RANKING OF PROPOSALS
- 8. AWARD
- 9. SPECIAL TERMS AND CONDITIONS.....
- 10. Vendor Questionnaire.....

Attachments:

- A - Non-Collusion Declaration
- B - Exhibit 10-O1 Consultant Proposal DBE Commitment
- C - Exhibit 10-Q Disclosure of Lobbying Activities
- D - Sample Consultant Agreement for Professional Consultant Senior Engineer Services

Attachment: Agreement with CWE (6330 : AUTHORIZATION TO AWARD AGREEMENTS FOR PROFESSIONAL CONSULTING SENIOR

1. NOTICE TO BIDDERS

1.1. Summary

The City of Moreno Valley is seeking qualified firms whose staff has in-depth experience in project management and implementation to serve as staff extension for the City's Public Works Department to manage various capital improvement plan (CIP) projects and perform project-related senior engineer and administrative duties as assigned.

You are hereby invited to submit a proposal for providing professional consultant senior engineer services for the Public Works Department. The selected consultants could be retained to serve the City for a period of three (3) years subject to the approval of the City Council.

1.2. Background

Moreno Valley was incorporated in 1984 as a General Law City, merging the communities of Moreno, Sunnymead, and Edgemont. The City operates under a Council-Manager form of government. The City Council is comprised of an elected Mayor and four Council Members elected by district. The City has a committed customer-service oriented workforce comprised of more than 450 employees who provide a wide-range of municipal services including Public Works, Economic Development, Community Development, Parks and Community Services, Financial and Management Services and Library services. The City contracts with Riverside County for Police and Fire services.

1.3. Timeline

Due Dates and RFP-Contract Award Schedule

The Request for Proposal (RFP) release, proposal review and consultant selection processes that leads to the award of a contract for the requested services are anticipated to be completed per the following schedule:

RFP Release Date	August 28, 2023
Questions & Answer Deadline	September 11, 2023, 2:00pm
Proposal Due Date	September 18, 2023, 2:00pm
Proposal Review	September 20, 2023
City Council Awards Contract	October 3, 2023
Notice to Proceed with Services	October 23, 2023

2. SCOPE OF SERVICES

2.1. General

Under general direction, the selected staff from successful firm shall provide Professional Consultant Senior Engineer Services for a contract time of up to three (3) years subject to the approval of the City Council. The duration of work shall be on an as-needed basis.

The consultant shall manage, oversee, evaluate, monitor, and participate in the management of multiple complex capital improvement plan (CIP) projects through all phases (planning, design and construction); supervise and oversee the work of professional, technical, and administrative support staff and/or other consultants; and perform other special assignment or related senior engineer and administrative duties as assigned. Depending on the workload and project needs, City anticipates a commitment of minimum of 20 hours/week up to 40 hours/week with a requirement of two (2) full days working in-person at the City Hall.

2.2. Specific Tasks and Duties

- 2.2.1 Works independently or with staff and/or other consultants to develop, implement, and monitor work plans to achieve assigned goals and objectives; contributes to development of and monitoring of performance against the division and project budgets; participates in developing, implementing and evaluating work programs, plans, processes, systems, and procedures to achieve division and City goals, objectives and performance measures consistent with the City's quality and service expectations.
- 2.2.2 Works with staff to ensure a high performance, customer service-oriented work environment which supports achieving City objectives and service expectations; provides leadership and participates in programs and activities that promote a positive employee relations environment.
- 2.2.3 Acts as Project Manager and manages, oversees, evaluates, and monitors assigned capital improvement projects through planning, design, or construction phases; prepares and maintains detailed project cost estimates and schedules; obtains all necessary regulatory approvals and permits to implement projects; responds to requests for information and clarifies and interprets engineering issues, regulations, codes, and requirements; chairs preconstruction meetings, reviews construction schedules, and prepares preconstruction meeting minutes; verifies available project funds and prepares purchase requisitions; reviews, evaluates, processes, initiates, and prepares change orders, amendments to agreements, schedule revisions, and updates, etc.; drafts reimbursement invoices to funding agencies and ensures payment; files notices of completion with County Recorder; releases retention payments to contractors; prepares and provides regular project status reports to division management; and other close-out documentation.
- 2.2.4 Participates in the selection and supervision of project consultants and contractors; prepares requests for proposals for outside services; reviews consultant plans,

- specifications, submittals, estimates, designs, drawings, and schedules of values for completeness, accuracy, scope of work, constructability, and compliance with federal, state, and local requirements; provides recommendations for acceptable alternative solutions to design errors and other issues; interviews contractor employees and verifies compliance with federal and state prevailing wage rates and notifies contractors of discrepancies; verifies rating of contractor bonds and insurance requirements and submits to City Attorney for approval; evaluates bids and recommends awarding of contracts; monitors consultant performance and inspects work for conformance with plans and specifications; assesses, identifies and facilitates complete resolution of noncompliance issues; reviews, verifies and processes consultant and contractor invoices and pay requests for payment.
- 2.2.5 Prepares complete project bid documents which include Plans, Specifications and Estimates (PS&E). Manages and participates in advertisement and bidding processes for projects; prepares bid notices; sets bid opening times and dates and attends as assigned; prepares necessary addenda; verifies bid results and bid numbers to identify errors and omissions and provides information to the City Attorney as necessary; performs detailed records and reference checks for contractors and subcontractors; prepares and submits required documentation to funding agencies to ensure compliance with bid requirements.
- 2.2.6 Coordinates project activities with other City departments and divisions, consultants, and external agencies for plan review and permitting; conducts and facilitates regular project staff meetings.
- 2.2.7 Serves as primary liaison between the City and contractors and consultants; works with contractors, consultants, and others to resolve conflicts and facilitate solutions; inspects project sites to ensure compliance with project specifications and City policies and resolve issues.
- 2.2.8 Prepares and updates a variety of complex and technical engineering project documentation, including staff reports, bid notices, project plans and specifications, requests to advertise and adopt plans and specifications, grant applications, various notices, statements of working days, final maps, bonds, agreements, right-of-way acquisitions and other documents; drafts interagency agreements for reimbursement and conveyance of easements; prepares future project cost estimates and schedules for the City's Capital Improvement Plan.
- 2.2.9 Analyzes and responds to requests for information and complaints from other public and governmental agencies, community and business groups, citizens, the media, and the public; represents the City and makes presentations at various meetings and public hearings.

- 2.2.10 Identifies, evaluates, selects, and submits grants for City Council approval; prepares and submits applications for various federal and state grant funding programs; ensures project compliance with grant requirements.
- 2.2.11 Oversees project right-of-way acquisition processes; performs research on project areas to ensure they are within existing City rights-of-way; recommends the acquisition of additional rights-of-way as necessary.

3. GENERAL INFORMATION

Proposals must be submitted electronically via the City of Moreno Valley e-Procurement System, OpenGov, **before the Due Date and Time as shown on Section 1.3 of this RFP**, at:

<https://procurement.opengov.com/portal/morenovalley>

The proposer shall provide a separate file for technical proposal and a separate file for cost proposal.

(Note: Cost proposals will not be opened during the review and rating of the technical proposals. Once the consultant ranking is made and top-ranked consultant is identified, only the cost proposal of the top-ranked consultant will be opened for review and contract negotiation purposes.)

Unless otherwise specified, proposals submitted by any other method such as hard copy, fax, or e-mail will be disqualified.

Proposals may be withdrawn on the OpenGov vendor portal prior to the scheduled submittal time and date for receipt of proposals.

Prospective bidder's are encouraged to not wait until deadline to submit proposals, as system-related questions may arise.

All questions, technical, commercial, or contractual in nature shall be directed to the Questions & Answers Section on the e-Procurement System, OpenGov. No phone calls will be allowed. Contact of the City of Moreno Valley personnel directly regarding this RFP is prohibited and may be grounds for elimination from the selection process. All questions regarding this RFP must be submitted through OpenGov no later than **the Questions & Answers Deadline as shown on Section 1.3 of this RFP**.

Bidders experiencing any technical difficulties with the bid submission process may contact OpenGov at (650) 336-7167 or utilize the chat bubble in the system. Neither the City, nor OpenGov, makes any guarantee as to the timely availability of assistance, or assurance that any given problem will be resolved by the bid submission deadline.

Right to Reject Proposals: City reserves the right to reject any and all proposals, to waive any non-material irregularities or informalities in any proposal, and to accept or reject any item or combination of items.

Execution of Agreement: If a prospective bidder is not able to execute an agreement within 10 days after being notified of selection, City reserves the right to select the next most qualified bidder or call for new proposals, whichever City deems most appropriate. (Sample template of agreement is attached).

Incorporation of RFP/Proposal: This RFP and the firm's response, including all promises, warranties, commitments, and representations made in the successful proposal will become binding contractual obligations and will be incorporated by reference in any agreement between City and prospective bidder.

Authorized Signatories: Company personnel signing the cover letter of the proposal, or any other related forms submitted must be authorized signers with the requisite authority to represent their firm and to enter into binding contracts.

Request For Proposal #2023-020
Title: Professional Consultant Senior Engineer Services

Validity of Proposals: Proposed services and related pricing contained in the proposal must be valid for a period of 60 Days after the due date.

Attachment: Agreement with CWE (6330 : AUTHORIZATION TO AWARD AGREEMENTS FOR PROFESSIONAL CONSULTING SENIOR

4. PROPOSAL CONTENT

The Consultant's Proposal shall be no more than 20 pages, excluding executive summary, resumes, dividers, and certificates. Proposals failing to provide sufficient information and assurances of performance to accurately assess each category of the required services and failing to comply with requirements and conditions of the RFP will not be given further consideration.

4.1. Executive Summary

The Consultant shall include an executive summary with general firm's information including full legal name and contact information, organizational structure (corporation, LLC, etc.), name(s) and title(s) of the principal owner(s), person(s) authorized to make commitments for your company identified in the corporate resolution, firm history and length of relevant experience, and current number of employees with emphasis on key personnel. The executive summary shall be limited to a maximum of one page.

4.2. Technical Proposal

The Consultant shall include, but not be limited to, the following items in the body of the proposal:

- 4.2.1 Proposer's approach and understanding of all necessary tasks and steps involved in completing the required services.
- 4.2.2 Responses with sufficient detail to enable City to evaluate your understanding of City's requirements, the suitability of your services and/or product(s) to meet City's requirements, the strength of your work plan, previous experience, and current workload.
- 4.2.3 A detailed work plan to reflect the methods and procedures that the proposer intends to use to provide the required services. The scope of services outlined in this RFP is only provided as a guide and does not include all the tasks as required to complete the work.
- 4.2.4 A list of deliverables or goals to be achieved for this service contract.
- 4.2.5 Procedures for perform Quality Assurance and Quality Control (QA/QC) on the services to be provided.
- 4.2.6 Related experience including relevant experience date, name of agency, and reference name/contact information.
- 4.2.7 A resource allocation matrix (exclude cost information).

4.3. Proposed Staff/Team

- 4.3.1 Information on key personnel who is expected to remain in service until completion of the contract.
- 4.3.2 Information on the back-up personnel in the event of the key personnel not available to provide the contracted services for certain short period during the contract duration.
- 4.3.3 Provide resumes of proposed staff/team members.

4.4. Required Statements

The Consultant's Proposal shall include the following:

- 4.4.1 A statement that this RFP shall be incorporated in its entirety as a part of the Consultant's Proposal.
- 4.4.2 A statement that this RFP and the Consultant's Proposal will jointly become part of the Agreement for Professional Consultant Services for this project when said Agreement is fully executed by the Consultant and the City Manager of Moreno Valley.
- 4.4.3 A statement that the Consultant's Services to be provided, and fees therefore, will be in accordance with the City's RFP except as otherwise specified in the Consultant's Proposal under the heading "ADDITIONS OR EXCEPTIONS TO THE CITY'S REQUEST FOR PROPOSAL."
- 4.4.4 A single and separate section with the heading "ADDITIONS OR EXCEPTIONS TO THE CITY'S REQUEST FOR PROPOSAL" (if needed) containing a complete and detailed description of all of the exceptions to the provisions and conditions of this Request for Proposal upon which the Consultant's Proposal is contingent and which shall take precedent over this RFP.
- 4.4.5 A statement of qualifications applicable to this project including the names, qualifications and proposed duties of the Consultant's Staff to be assigned to this project; a listing of recent similar projects completed including the names, titles, addresses and telephone numbers of the appropriate persons whom the City could contact. If one or more of the Consultant's staff should become unavailable, the Consultant may substitute other staff of at least equal competence only after prior written approval by the City.
- 4.4.6 A resource allocation matrix must be submitted with the Proposal. The resource allocation matrix must list detailed tasks in rows and the appropriate individual (Job Title Only) as well as the number of hours that these individuals will be working on each task listed, will be included in adjacent columns. The resource allocation matrix and the project design schedule are required of both the primary consultant, as well as any sub-consultant. In addition, the applicable construction support services consultant must list the type and number or hours of geotechnical tests being proposed, as well as the type and number of hours of inspection or survey work within the Proposal. Failure to do so will result in the Consultant's Proposal being deemed incomplete and it will not receive further consideration. The construction support services Consultant is not required to provide a Project Schedule with milestones.
- 4.4.7 A statement of sub-consultant's (include relief personnel) qualifications applicable to this project including the names, qualifications and proposed duties of the sub-consultant's staff to be assigned to this project; a listing of recent similar projects completed including the names, titles, addresses, and telephone numbers of the appropriate persons whom the City could contact.
- 4.4.8 A statement that the Consultant acknowledges and understands that the Consultant will not be allowed to change the sub-consultant without written permission from the City.
- 4.4.9 A statement that all charges for Consultant (construction) services is a "Not-to-Exceed Fee" which must include conservatively estimated reimbursable expenses, as submitted with and made a part of said Consultant's Proposal.
- 4.4.10 A statement that the Consultant will document and provide the results of the work to the satisfaction of the City. This may include preparation of field and final reports, or similar evidence of attainment of the Agreement objectives.
- 4.4.11 A statement that the Consultant will immediately document and notify the City of any defects or hazardous conditions observed in the vicinity of the project site prior, during, or after the construction work.

- 4.4.12 A copy of the Consultant's hourly rate schedule and a statement that said hourly rate schedule is part of the Consultant's Proposal for use in invoicing for progress payments and for extra work incurred that is not part of this RFP. An itemized cost breakdown for the work described herein must be submitted in a separate file, entitled Cost file, as part of the Consultant's Proposal submittal. All extra work will require prior approval from the City.
- 4.4.13 A statement that the Consultant will not discriminate against any employee or applicant for employment because of race, color, religion, sex, or national origin.
- 4.4.14 A statement that all federal laws and regulations shall be adhered to notwithstanding any state or local laws and regulations. In a case of conflict between federal, state or local laws or regulations the strictest shall be adhered to.
- 4.4.15 A statement that the Consultant shall allow all authorized federal, state, county, and City officials access to place of work, books, documents, papers, fiscal, payroll, materials, and other relevant contract records pertinent to this special project. All relevant records shall be retained for at least three years.
- 4.4.16 A statement that the Consultant shall comply with the Davis-Bacon Fair Labor Standards Act (40 USC 276-a through a-7), and the implementation regulations issued pursuant thereto (29 CFR Section 1, 5), any amendments thereof and the California Labor Code. Pursuant to the said regulations, entitled "Federal Labor Standards Provisions," Federal Prevailing Wage Decision" and State of California prevailing wage rates, respectively.
- 4.4.17 A statement that the Consultant shall comply with the Copeland Anti-Kickback Act (18 USC 874) and the Implementation Regulation (29 CFR 3) issued pursuant thereto, and any amendments thereof.
- 4.4.18 A statement that the Consultant offers and agrees to assign to the City all rights, title, and interest in and to all causes of action it may have under Section 4 of the Clayton Act (15 USC Sec. 15) or under the Cartwright Act (Chapter 2 [commencing with Section 16700] of Part 2 of Division 7 of the Business and Professions Code), arising from purchases of goods, services, or materials pursuant to the public works or the subcontract. This assignment shall be made and become effective at the time the City tenders final payment to the Consultant, without further acknowledgment by the parties.

4.5. [Required Forms](#)

- 4.5.1 Non-Collusion Declaration Form
- 4.5.2 Exhibit 10-O1, Consultant Proposal DBE Commitment
- 4.5.3 Exhibit 10-Q, Disclosure of Lobbying Activities

4.6. [Cost Proposal](#)

- 4.6.1 A Cost Proposal that includes all costs associated with the requested services for the anticipated service length of up to three (3) years.
- 4.6.2 A rate schedule aligned with titles in the resource allocation matrix in Technical Proposal.
- 4.6.3 The general Scope of Services outlined herein is only provided as a guide in this Request for Proposal.

4.6.4 Itemized tasks and corresponding costs must be identical to the detailed Scope of Services included as part of the Proposer’s Technical Proposal.

Attachment: Agreement with CWE (6330 : AUTHORIZATION TO AWARD AGREEMENTS FOR PROFESSIONAL CONSULTING SENIOR

5. PROSPECTIVE BIDDER QUALIFICATIONS

5.1. Prospective Bidder Qualifications

The intent of this RFP is to evaluate the proposals, determine the prospective bidder's that are in the competitive range, and select proposers that will provide the highest level of professional services for City.

5.2. Minimum Qualifications:

The proposed staff who will be providing consultant senior engineer services shall have the knowledge of:

- 5.2.1 Theories, principles and practices of civil engineering design and construction.
- 5.2.2 Principles and modern techniques and commonly used materials and equipment used in design, construction, and maintenance of various public works projects.
- 5.2.3 Federal, state, and local laws, regulations, and court decisions applicable to public works projects.
- 5.2.4 Information technology and computer capabilities to perform daily engineering tasks.
- 5.2.5 Principles and practices of sound business communication, teamwork, and work ethics.

The proposed staff shall also possess the ability to:

- 5.2.6 Prepare, direct preparation of and review complex engineering designs, plans, specifications, and legal contracts.
- 5.2.7 Perform difficult technical research and analyze complex engineering and mathematical problems, evaluating alternatives and recommending or adopting effective courses of action.
- 5.2.8 Plan, organize, manage, and integrate engineering design and construction activities.
- 5.2.9 Design issues, analyze problems, evaluate alternatives, and develop sound and independent judgements and recommendations.
- 5.2.10 Understand, interpret, explain, and apply federal, state, and local policy, law, regulations, and court decisions applicable to public works project implementation.
- 5.2.11 Operate a personal computer using standard or customized software applications appropriate to assigned tasks.
- 5.2.12 Supervise and evaluate the work of professional consultants and construction contractors.
- 5.2.13 Prepare clear, concise, and comprehensive correspondence, reports, and other written materials.
- 5.2.14 Organize, set priorities, and exercise sound independent judgement within areas of responsibility.

- 5.2.15 Exercise tact and diplomacy in dealing with sensitive and complex issues and situations.
- 5.2.16 Establish and maintain effective working relationships with City management, staff, contractors, consultants, representatives of other governmental and utility agencies, business and community groups, citizens, the public and others encountered in the course of work.

5.3. Education, Training, and Licenses:

- 5.3.1 A bachelor's degree in civil engineering.
- 5.3.2 A minimum of five years of professional civil engineering experience.
- 5.3.3 At least three years' experience in a supervisory or program management capacity.
- 5.3.4 A valid California Civil Engineering License.
- 5.3.5 A valid California driver's license and the ability to maintain insurability under City's vehicle insurance policy.

6. SUBMISSION OF PROPOSALS

Written responses to the RFP must be prepared as specified in proposal content, as to form, content, and sequence. No changes to responses may be made after the submittal deadline.

The Proposal for the requested shall be uploaded to OPENGOV on or before, but no later **the Date and Time as shown on Section 1.3 of this RFP**. Any responses received after this time will not be considered by the City.

The response shall be signed by an officer, or officers, authorized to execute legal documents on behalf of the respondent.

The City reserves the right to waive informalities in any proposal, to reject any or all proposals, to reject one part of a proposal and accept the other, except to the extent that proposals are qualified by specific limitations, and to make awards to the Consultants whose proposal is most beneficial to the needs of the City. Bidders are solely responsible for on time submission of their electronic bid. The City will only consider bids that have been transmitted successfully and have been issued an ebid confirmation number with a time stamp from the Bid Management System indicating that the bid was submitted successfully. Transmission of bids by any other means will not be accepted. Bidders shall be solely responsible for informing themselves with respect to the proper utilization of the bid management system, for ensuring the capability of their computer system to upload the required documents, and for the stability of their internet service. Failure of the bidders to successfully submit electronic bids shall be at the bidders' sole risk and no relief will be given for late and/or improperly submitted bids. Bidders experiencing any technical difficulties with the bid submission process may contact OpenGov at (650) 336-7167 or utilize the chat bubble in the system. Neither the City, nor OpenGov, makes any guarantee as to the timely availability of assistance, or assurance that any given problem will be resolved by the bid submission deadline.

7. EVALUATION AND RANKING OF PROPOSALS

In accordance with the Chapter 3.12 PURCHASING City Municipal Code's objective of selecting the most qualified consultant for providing the requested services, a Review Board which is composed of appropriate staff representatives and/or qualified outside representatives, will review the proposals received and select the most qualified firms. Review Board shall rank the prospective bidder's based upon the following criteria:

No.	Evaluation Criteria	Scoring Method	Weight (Points)
1.	<p>The Firm's General Experience and Qualification Information (20 points)</p> <p>Information about the company (and all sub-Consultants) including professional licenses held; ability to furnish required insurance and meet stipulations of the City's "boiler plate" agreement; details about comparable projects completed by the firm, as well as local experience; and its ability to provide the required services in an efficient and expeditious manner.</p>	0-100 Points	<p>20 (20% of Total)</p>
2.	<p>Experience of Key Personnel (60 points)</p> <p>Background on key personnel (including all sub-consultants) qualifications, abilities, familiarity with state and federal procedures, local experience on comparable projects and length of service with the firm, reference information preferably with municipal agencies, and proven track record and depth of understanding/knowledge of the proposed staff.</p>	0-100 Points	<p>60 (60% of Total)</p>
3.	<p>3. Project Approach/Understanding (20 points)</p> <p>Understanding of requested services and how the Consultant team plans to address them; the approach, methods, and procedures to be used on managing and implementing CIP projects; the management approach and organization necessary to complete the specific project or projects; and outline quality control measures to ensure delivery of a quality services on time, within budget that provides a cost efficient, timely and predictable execution of the project implementation.</p>	0-100 Points	<p>20 (20% of Total)</p>

8. AWARD

- 8.1 After conclusion of the Evaluation and Ranking of Proposals processes, a Notification of Intent to Award may be sent to any prospective bidder's selected. City may make multiple awards.
- 8.2 Award is contingent upon the successful negotiation of final contract terms and the approval of City. Negotiations shall be confidential and not subject to disclosure to competing prospective bidder's unless an agreement is reached. If contract negotiations cannot be concluded successfully, City may negotiate a contract with the next best qualified prospective bidder's or withdraw the RFP. In the event City does not approve the recommendation to award, the RFP may be cancelled without any cost or obligation of City.
- 8.3 Prices are firm fixed prices during each contract period.
- 8.4 Prices shall be negotiated for each mutually exercised optional renewal period.

9. SPECIAL TERMS AND CONDITIONS

9.1. Termination

- 9.1.1 If, in the opinion of the City of Moreno Valley, the awarded consultant fails to perform or provide prompt, efficient service, the City must have the right to terminate or cancel the Agreement upon 10 calendar day's prior written notice with or without cause and pay Consultant for the value of the actual work satisfactorily performed to the date of termination.
- 9.1.2 The City of Moreno Valley must have the right to terminate or cancel the Agreement upon 30-day's written notice without cause and pay Consultant for the value of actual work satisfactorily performed to the date of termination.
- 9.1.3 These rights are in addition to any other rights that City may have available.

9.2. Public Employees Retirement Law (CalPERS)

- 9.2.1 CalPERS Indemnity. To the fullest extent permitted by law, in addition to obligations set forth in this section, in the event that any person providing services under this Agreement is determined by a court of competent jurisdiction or CalPERS to be eligible for enrollment in CalPERS as an employee of the City, to the fullest extent of the law, Consultant shall indemnify, defend, and hold harmless City for any costs and expenses incurred by City, including without limitation, payment that City is required as a result to make to CalPERS, whether in the form of employee and/or employer contributions, taxes, or any similar obligations, as well as for the payment of any penalties and interest.
- 9.2.2 CalPERS Participation. As set forth in this Agreement and in the Request for Proposal, City has an obligation to treat all persons working for or under the direction of Consultant as an independent contractor of City and agents and employees of Consultant, and not as agents or employees of City. Consultant and City acknowledge and agree that City participates in a defined benefit plan ("CalPERS"), and that it is possible that CalPERS may find that persons providing services pursuant to this Agreement are employees of City and should be registered with the CalPERS as employees of City.
- 9.2.3 CalPERS Retiree Disclosure. Consultant hereby expressly agrees to clearly and conspicuously disclose to City in writing any and all persons working for Consultant who are retirees under the California Public Employees' Retirement System (CalPERS) whom receives a monthly CalPERS retirement allowance, and whom are, subject to City approval, assigned by Consultant to provide services to City under the Agreement, prior to such person performing any services hereunder. Nothing herein shall be deemed or interpreted to limit a CalPERS retiree's obligations under applicable law, rules or regulations.
- 9.2.4 Joint Cooperation. In the event that CalPERS initiates an inquiry that includes examination of whether individuals providing services under this Agreement to City are City's employees, Consultant shall within five days and share all communications and documents from CalPERS that it may legally share. In the event that either Consultant or City files an appeal or court challenge, Consultant and City each agree to cooperate with each other in responding to the inquiry and any subsequent administrative appeal or court challenge of an adverse determination.

9.3. Managing Federal and State Funded Projects

As part of the senior engineer services, the Consultant may be assigned to manage certain federal and state funded projects under FHWA, HUD, FEMA, and/or State Bills (SB). The work and/or services to be provided by the Consultant shall comply with all pertinent local, State, and Federal laws and regulations. The Consultant, therefore, shall be legally able to perform services for Federal or State funded projects.

A contract DBE goal has not established for the purpose of this RFP. However, the Consultant is required to submit the Consultant Proposal DBE Commitment (Exhibit 10-O1) as included in this RFP along with the proposal to meet Caltrans Local Assistance DBE commitment requirements. Prior to starting to work on a Federal or State funded project, the Consultant shall submit to the City for approval the Consultant Contract DBE Commitment (Exhibit 10-O2) with the Contract DBE Goal specifically determined/approved for that project.

The Consultant shall also be required to submit the Disclosure of Lobbying Activities (Exhibit 10-Q) as included in this RFP along with the proposal.

9.4. 9.4 Indemnification

- 9.4.1 Design Professional Services. To the fullest extent permitted by law, including but not limited to Civil Code Section 2782.8, in performing “design professional services” as defined in Section 2782.8, the Consultant agrees to indemnify, defend, and save the City, the Moreno Valley Community Services District (CSD), and the Moreno Valley Housing Authority (MVHA), their officers, agents and employees harmless from any and all liability, claims, demands, damages, or injuries to any person, including injury to the Consultant's employees, and all claims which arise from or are connected with the negligent, reckless, or willful misconduct in the performance of or failure to perform the work or other obligations of the Consultant under this RFP and/or related Agreement, or are caused or claim to be caused by the negligent, reckless or willful misconduct of the Consultant, its officers, agents or employees, or its subconsultant(s) or any person acting for the Consultant or under its control or direction; provided, however, that this indemnification and hold harmless shall not include claims arising from the sole negligence or willful misconduct of the City, MVHA, and CSD, their officers, agents or employees.
- 9.4.2 For all non-design professional services, Consultant shall indemnify, defend, and save the City, the Moreno Valley Community Services District (CSD), and the Moreno Valley Housing Authority (MVHA), their officers, agents and employees harmless from any and all liability, claims, demands, damages, or injuries to any person, including injury to the Consultant's employees and all claims which arise from or are connected with the performance of or failure to perform the work or other obligations of the Consultant, or are caused or claim to be caused by the acts of the Consultant, its officers, agents or employees, or its subconsultant(s) or any person acting for the Consultant or under its control or direction; provided, however, that this indemnification and hold harmless shall not include claims arising from the sole negligence or willful misconduct of the City, MVHA, and CSD, their officers, agents or employees.
- 9.4.3 The protections in this Section shall be in addition to those set forth in Section 9.2 of this Request for Proposals.

10. VENDOR QUESTIONNAIRE

10.1. Please download the documents below, complete and upload.*

Please download the below documents, complete, and upload.

- [\[B\] Exhibit 10-O1 Consultant...](#)
- [\[C\] Exhibit 10-Q Disclosure...](#)
- [Non-Collusion Declaration.pdf](#)

*Response required

EXHIBIT "B"



Creating a Better Tomorrow, Today.™

Proposal for Professional Consultant
Senior Engineer Services

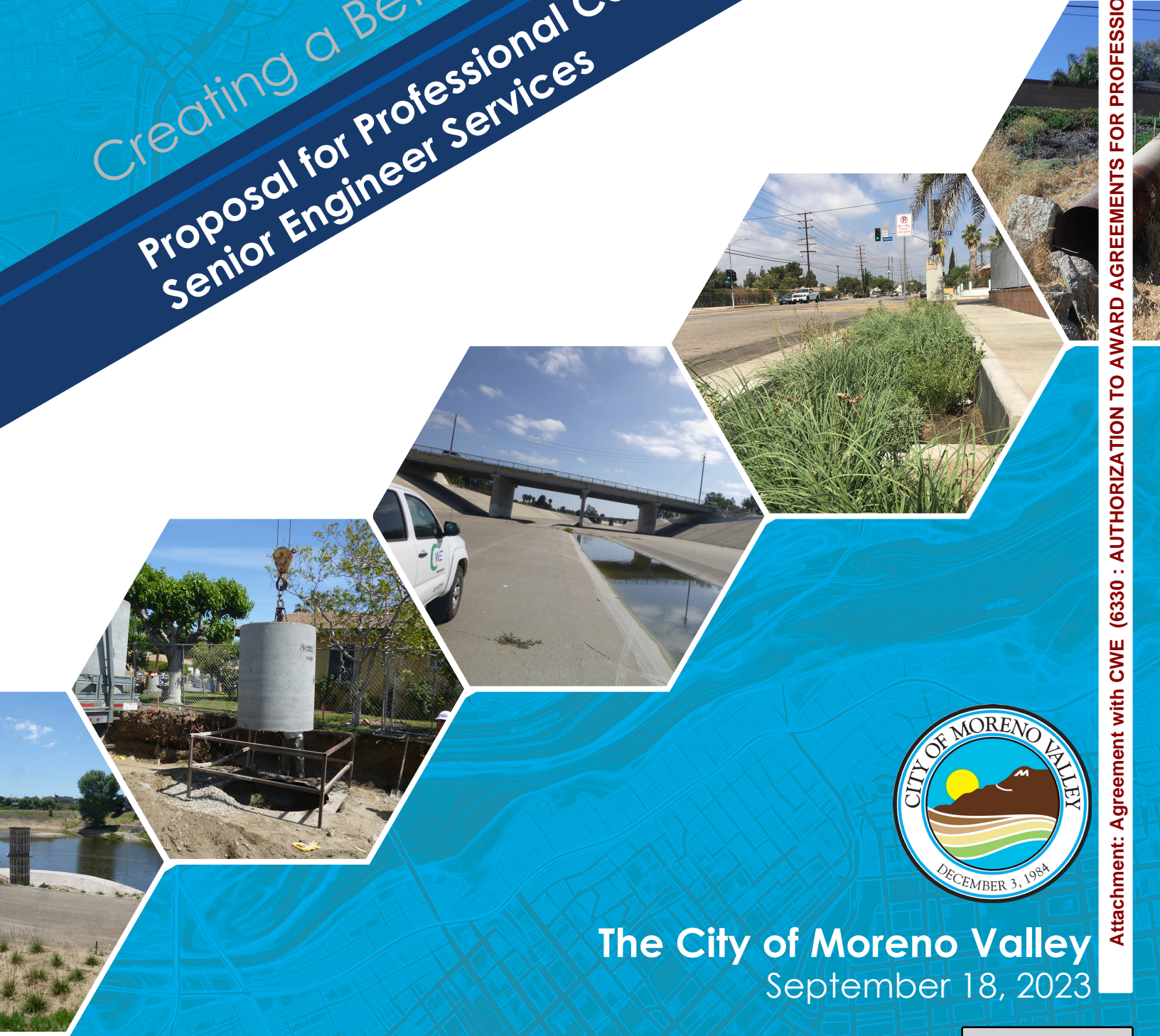

The City of Moreno Valley
September 18, 2023

Attachment: Agreement with CWE (6330 : AUTHORIZATION TO AWARD AGREEMENTS FOR PROFESSIONAL CONSULTING SENIOR

**CWE**

1561 E. ORANGETHORPE AVENUE
 SUITE 240
 FULLERTON, CA 92831-5202
 (714) 526-7500 PHONE
 (714) 526-7004 FAX
 www.cwecorp.com

September 18, 2023

City of Moreno Valley
 14177 Frederick St.
 Moreno Valley, CA 92552

Proposal for Professional Consultant Senior Engineer Services

To Whom It May Concern,

The City of Moreno Valley has emerged as one of the fastest growing Cities in the United States. With a population of over 213,000, Moreno Valley is the second largest city in Riverside County with high disposable income growth and a booming daytime employment population. To accommodate this burgeoning population and workforce, the City Council approved the continuation of *Momentum MoVal* to manage and maximize Moreno Valley's public infrastructure to ensure an excellent quality of life; develop and implement innovative, cost-effective infrastructure maintenance programs, public facilities, management strategies, and capital improvement programming; and efficient project delivery. CWE is well-versed in facilitating the implementation of Capital Improvement Programs (CIPs) to deliver municipal infrastructure, roadway/street improvement and rehabilitation design services, and project and program management to flourishing cities in Southern California.

Our team features a 28-year veteran design delivery Principal, Vik Bapna, PE, ENV SP, CPSWQ, QSD/P, as well as award-winning personnel who are experienced with myriad street design projects of different sizes and scopes. Vik will be supported by Resource Manager, Farooq Qureshi, MBA, ENV SP who has over 20 years of experience delivering public infrastructure staff augmentation programs to ensure the right resources are mobilized for the continuity of services. Our designated on-site Senior Engineer for this contract is Alexander Torres, PE. Alex understands the local environment around Moreno Valley as a resident of neighboring Rancho Cucamonga.

We look forward to working with the City and welcome the opportunity to further discuss our qualifications. I am authorized to bind CWE to the terms of this proposal and enter CWE into a contractual commitment with the City. CWE has the ability to furnish required insurance and meet stipulations of the City's "boiler plate" agreement. We have read and acknowledge the addenda, and Questions and Answers posted on the electronic bid system. The contents of this Proposal will remain valid for a period of sixty (60) days. If you have any questions or require additional information, please contact me via phone at (714) 262-0180, or vbapna@cwecorp.com.

Respectfully submitted,

CWE

Vik Bapna, PE, ENV SP, CPSWQ, QSD/P
 Principal



Table of Contents



TABLE OF CONTENTS..... II

1. EXECUTIVE SUMMARY 1

2. TECHNICAL PROPOSAL 2

 2.1 UNDERSTANDING, APPROACH, AND WORK PAN 2

 2.2 PROGRAM MANAGEMENT QUALITY ASSURANCE/QUALITY CONTROL 5

 2.3 RELATED EXPERIENCE 7

 2.4 STAFFING AND RESOURCE MANAGEMENT PLAN 11

3. PROPOSED STAFF/TEAM 13

 3.1 MEET YOUR SENIOR ENGINEER 14

4. REQUIRED STATEMENTS 37

5. REQUIRED FORMS 38

6. COST PROPOSAL..... 38

7. ADDITIONS OR EXCEPTIONS TO THE CITY'S RFP 38





City of Moreno Valley
 Consultant Senior Engineer Services

1. Executive Summary

Founded in 2006 by Principals Vik Bapna, PE and Jason Pereira, PE, CWE’s trusted and distinguished civil engineering, water resources, and environmental engineering have enhanced the quality of life of our esteemed communities. We have served over 250 public municipalities, utility companies, and federal agencies by consistently delivering on our promise of **Creating a Better Tomorrow, Today™**. Our award-winning industry leaders cultivate the engineering protégés and environmental stewards of tomorrow to deliver forward-thinking results for the communities we live work and play in, leaving them better for the next generation. This is the CWE standard.

Our work’s positive impact on local communities has been recognized on a local and national scale. 12 of our projects have received 23 awards from the US Environmental Protection Agency (EPA), American Society of Civil Engineers (ASCE), American Public Works Association (APWA), Engineering News Record (ENR), California Stormwater Quality Association (CASQA), American Academy of Environmental Engineers and Scientists (AAEES), and *Stormwater Solutions* magazine.



CWE has extensive experience working with Southern California municipalities to secure over \$109 million in grant money for environmental improvement projects. We assisted the City of San Fernando with \$10 million in grant funding assistance for the Regional Park Infiltration Project. Furthermore, our engineers suggested the City include street reconstruction as part of this stormwater project’s multiple benefits to enable the City to pay for street improvements with a stormwater grant. Other relevant project experience includes El Monte On-Call General Professional Services, City of Torrance Green Streets, Laurel Canyon Boulevard Green Street, and City of Los Angeles TOS 14 LA River.

Our key personnel in this proposal is **Senior Engineer (On-Site) Alex Torres, PE, QSD/P**. He will be supported by technical and management resources Steven Bell, PE, ENV SP, CFM, QSD, Katie Harrell, PE, ENV SP, QSD, and Larry Tortuya PE, ENV SP, CFM, QSD/P, in addition to other home office support personnel.

CWE has been recognized as a “Hot Firm” by the Zweig Group four times and a “Best Firm to Work For” seven times. These honors highlight not only CWE’s significant business growth but also our growing staff’s sense of purpose and happiness at CWE. We are eager to show the City what benefits our dedicated engineers can bring to your communities and demonstrate how engaged employees with the same goal of **Creating a Better Tomorrow, Today™** prompt clients to return.



Firm Name/Type	CWE (S-Corporation)
Headquarters	1561 E Orangethorpe Ave, Suite 240, Fullerton, CA 92831 714-526-7500
Principal Owners:	Vik Bapna (Contractual Signatory), Jason Periera, Farooq Qureshi, Katie Harrel

With 57 total staff and 16 professional engineers (PEs), CWE is fully prepared to fulfill the orders of this contract. Our talented professionals include registered civil engineers and environmental engineers; engineers-in-training, licensed surveyors; Computer Aided Design (CAD) drafters; Qualified SWPPP Developers and Practitioners (QSD/Ps); Geographic Information System (GIS) specialists; Envision™ Sustainability Professionals (ENV SP), environmental scientists, inspectors, field technicians, and related technical and project support personnel.





2. Technical Proposal

2.1 Understanding, Approach, and Work Plan

This section describes our understanding, approach and work plan to delivering services for the complex Capital Improvement Plan (CIP) projects that will be included under this contract. Our understanding and approach differentiate us from other respondents due to our unparalleled expertise and experience in On-Call/As-Needed contracts and program management. CWE is no stranger to On-Call/As-Needed contracts and has been successfully providing professional services to multiple concurrent clients on a task order basis. Our project professionals are accustomed to responding on short notice and providing highly specialized services. Our depth of resources facilitates our availability for this type of contract vehicle with the City of Moreno Valley.

CWE proposes to meet the objectives of services needed, including in-house city projects, capital improvement projects assigned to consultants, oversight of design from consultants, and grant acquisitions. Workplans will be implemented at the onset of these services as they are assigned. Each workplan will include the tasks necessary for each milestone deliverable and the hours of effort needed to accomplish each task on a weekly basis. The workplan will not be limited to CWE's involvement in the project but will include the city forces and other consultants/subconsultants that are part of the project. These workplans will be in-line with CWE's project management approach that implements project management through a combination of administrative steps and procedures to assure that project scope and objectives are met, on-time and within budget. Project management elements are characterized by frequent client communication, project team coordination, decision documentation, and multi-step quality control. CWE will work with the project team to determine the best approaches to communication, working through concerns, and providing timely responses. CWE has used this management program with great success on many project types and sizes. CWE has received numerous letters of commendation from satisfied clients attesting to the success of our project management program.

CWE has reviewed the City's CIP and observed the following categorical breakdown of projects on recently completed projects, current projects, and future projects:

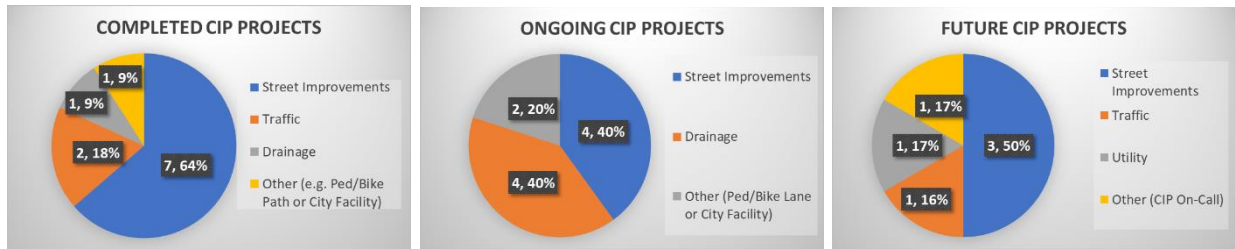

The trend of project types suggest most CIP projects are either drainage or street projects with a small percentage of projects being traffic, pedestrian and bike lanes, and utility like the MVU Integrated Resource Plan currently being advertised. CWE understands that we will be providing an on-site Senior Engineer to support the CIP and other initiatives of the City. The role may be 20-40 hours per week or on an as-needed basis. This role will manage, oversee, evaluate, monitor and participate in the planning, design, construction, and management of projects for the City over the next three (3) years. Our preference would be to have personnel positioned on-site for the performance of all services, but we are open to a hybrid work model if that is what the City prefers. CWE will provide mobile phone connectivity, email access, as well as a laptop computer to our assigned staff. If the City has a dedicated workstation and workspace available, and would like to assign a City email address to our staff, that would be beneficial.

Alex Torres, PE, QSD/P, the designated **On-Site Senior Engineer** on this proposal, contributed to the completed SR-60/World Logistics Center (WLC) Interchange project, and the ongoing Sunnymead and Moreno MDP projects, in he which a key participant in advancing the design and ensuring it met all





City of Moreno Valley
 Consultant Senior Engineer Services

City guidelines and requirements. In the SR-60/WLC project, which is a reconfiguration of the interchange to increase traffic capacity for travel to the WLC, which is a proposed corporate campus of 29 warehouse sites acting as a central hub for 40% of the nation’s imports coming from the ports of Los Angeles and Long Beach, while also being an environmentally sustainable Net Zero GHG project, the largest of its kind in the nation. On this project, Alex provided the stormwater treatment within Caltrans and Moreno Valley MS4’s and managed the traffic study during the planning (PA/ED) phases. Alex’s contributions on the Sunnymead and Moreno MDP projects consisted of leading the technical analysis and design of storm drain improvements to alleviate flooding within those Riverside County Flood Control master planned watersheds. These project experiences have provided close collaboration with City officials that have enriched CWE’s understanding of City requirements and guidelines and are also in parallel with the majority of CIP projects, which are street and drainage projects. While not with the City, CWE also has worked extensively with other agencies providing design services for traffic, utility, and pedestrian and bike lanes, like the current LA River Bike Lanes Project with the City of Cudahy.

CWE has the proven ability to lead and produce deliverables for all of these project types, while also assisting the City with oversight of other CIP projects contracted to consultants and assisting with all other tasks and duties under this contract. For each task assigned, CWE will deploy the following task order process:

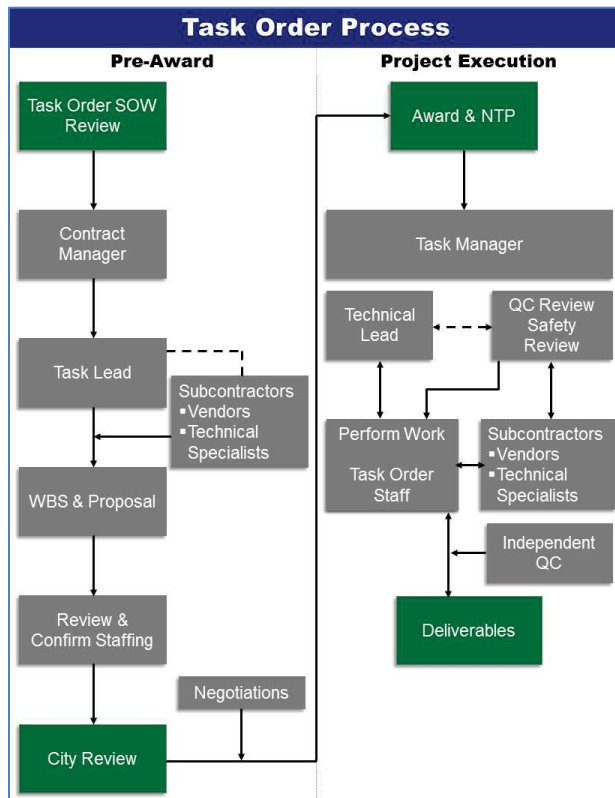

CWE will apply this task management approach to the pertinent phase the project at hand is in. Whether it’s being involved during the planning, design, and construction phases or just one or two of the phases, CWE will ensure the project is delivered per schedule and budget requirements. **Our goals and deliverables are focused around: Communication, Schedule and Cost Control, Robust PS&Es, and Funding Sources (Grants).** The CWE lead will coordinate team activities and keep the City informed of important progress and transmittals. We have found that a critical key to successful project completion is maintaining communication with the client to discuss progress, identify problems, assign priorities, coordinate the implementation of solutions, and accept feedback. Coordination, coupled with progress meetings, avoids delays and ensures that projects are completed on schedule and within budget. We will communicate with the project team as frequently as necessary to ensure that the efforts for the project are coordinated and moving forward on schedule. Resolution of concerns and questions as quickly as possible will keep the project on schedule. Of course, CWE will

keep a log of all correspondences including emails and prepare meeting agendas and meeting minutes for all meetings. If the project is in the construction stage, CWE will ensure that contractor submittals are consistent with project plans and specifications while promptly providing RFI requests and dynamic solutions on the field.

This successful work plan management process would not be possible without CWE’s vast experience in CIP projects. Whether it’s a complete streets project, a water or sewer improvement, or a storm drain plan, CWE has implemented workplans that successfully deliver these projects adhering to city of Moreno Valley and other local stakeholders criteria like Riverside County Flood Control and Water Conservation

Attachment: Agreement with CWE (6330 : AUTHORIZATION TO AWARD AGREEMENTS FOR PROFESSIONAL CONSULTING SENIOR





City of Moreno Valley
Consultant Senior Engineer Services

District (RCFC&WCD), Riverside County Transportation Department (RCTD) and California Department of Transportation (Caltrans). CWE will ensure the designs have been validated by proper hydrology and hydraulic analysis and that any required Low-Impact Development (LID) Best Management Practices (BMPs) and other treatment BMPs are implemented in accordance with the Water Quality Management Plan (WQMP) for the Santa Ana River Watershed of Riverside County. CWE is aware of the new 2022 Construction General Permit (CGP) by the California State Water Resources Control Board (WRCB) effective on September 1st, 2023, and specifically how the threshold of redevelopment projects requiring treatment was reduced from 10,000 SF to 5,000 SF of new impervious surface. Lastly, CWE will ensure all bid items are covered in the cost estimate using real-time unit prices and are correctly represented in the Greenbook specifications.

Goal: Coordination/Communication

The CWE lead will coordinate team activities and keep the City informed of important progress and transmittals. We have found that a critical key to successful project completion is maintaining communication with the client to discuss progress, identify problems, assign priorities, implement solutions, and accept feedback. Coordination both internally and with other stakeholders and agencies, coupled with progress meetings, avoids delays and ensures that projects are completed on schedule and within budget. We will communicate with the City as frequently as necessary to ensure that efforts for the project are coordinated and moving forward on schedule. Resolving concerns and questions as quickly as possible will keep the project on schedule.

Goal: Project Scheduling

The CWE lead will develop and use comprehensive project schedules to regularly monitor progress and upcoming work items. This has proven successful in keeping track of forthcoming critical issues and decisions. The CWE lead will keep the City apprised of planned work, project progress, and deliverables. The CWE lead will notify the City of any critical issues and changes in the anticipated project progress and delivery of key tasks.

Goal: Budget Control

Two methods for maintaining budgetary control are frequent project accomplishment evaluations and periodic project expenditure monitoring. The CWE lead will regularly evaluate the project scope of work and the City's objectives to monitor and identify changes that may affect project costs. This approach has proven successful in reducing client costs and developing a clear time schedule for project delivery. CWE recognizes the need for project budget and progress tracking in order to minimize the risk of cost overruns or project deficiencies. Each week, our lead reviews the task charges to ensure accuracy. Each month, our lead receives project summary reports detailing hours charged and costs for that particular period and for the project to date. Our monthly invoices include hours and costs charged to the job for that month, and a summary that shows the amount spent to date and the budget remaining. They are accompanied by a project status report that shows tasks worked on for the month, their percent complete, and critical items for the tasks that remain to be resolved. Regular communication with City staff is always a high priority for the CWE lead to ensure surprises do not occur on the project.

Goal: Constructible, Maintainable PS&Es

At CWE, we pride ourselves on developing solid PS&Es that are sensible and constructible. Our team members have extensive experience in the construction management of civil engineering projects, which gives them a foundation of sound, realistic engineering principles and the know-how to understand what project elements will work best in any given site and design. This experience matters: CWE-designed projects have an average rate of just 4% change orders during construction, compared to the industry average of 10%. Our expertise has saved our clients hundreds of thousands of dollars in change orders.

CWE takes O&M costs into consideration at every stage of the project, from conceptualization through final design. Our O&M expertise stems from our staff's experience at Los Angeles County DPW (LACDPW) and other Southern California Agencies, and ensures projects are maintainable after construction. The



health and safety of O&M employees maintaining the systems is very important to us, as we share the LACDPW’s “Safety” value and incorporate O&M safety considerations into each of our projects.

Goal: Grant/Funding Support

We have extensive experience providing comprehensive support to our clients in identifying grant opportunities as part of long-term planning efforts. CWE has prepared numerous grant applications and successfully obtained funding for plans and projects, resulting in over \$109 million in grant funding for our clients.

CWE has worked on over 35 grant-funded projects receiving funding from 15 agencies including the Los Angeles County Flood Control District (LACFCD), US Bureau of Reclamation, State Water Resources Control Board (SWRCB), California Department of Transportation (Caltrans), Santa Monica Bay Restoration Commission, and Metropolitan Water District of Southern California (MWD) to name a few. These projects include the San Bernardino County Flood Control District Stormwater Resource Plan, City of Bell Gardens John Anson Ford Park Infiltration Cistern, San Gabriel Valley Council of Governments (SGVCOG) Rio Hondo Load Reduction Strategy (LRS), City of San Fernando Regional Park Infiltration, and award-winning City of Los Angeles Laurel Canyon Boulevard Green Street Design-Build projects.

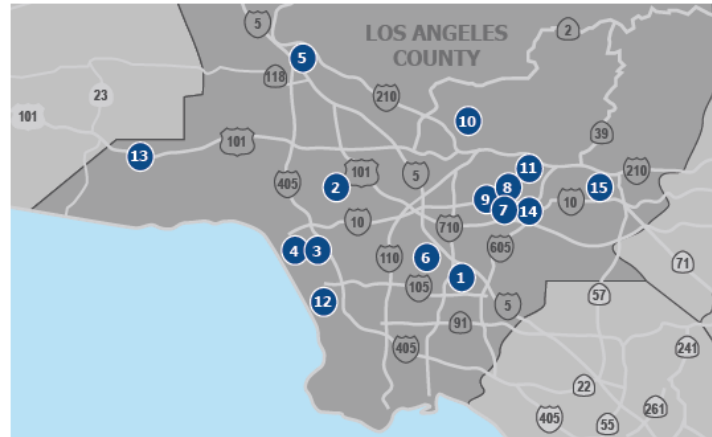

#	PROJECT	AWARDED
1	JOHN ANSON FORD PARK INFILTRATION CISTERN	\$10M
2	BURTON WAY MEDIAN GREEN STREET	\$5M
3	MESMER LOW-FLOW DIVERSION	\$950K
4	WASHINGTON BOULEVARD P3 URBAN RUNOFF DIVERSION	\$3.6M
5	SAN FERNANDO REGIONAL PARK INFILTRATION	\$9.2M
6	SALT LAKE PARK INFILTRATION CISTERN	\$20M
7	ALHAMBRA WASH DRY-WEATHER DIVERSION	\$2.7M
8	EATON WASH DRY-WEATHER DIVERSION	\$1.8M
9	RUBIO WASH DRY-WEATHER DIVERSION	\$2.9M
10	ALTADENA MARIPOSA GREEN STREET DEMONSTRATION PROJECT	\$700K
11	PLYMOUTH SCHOOL NEIGHBORHOOD SW CAPTURE DEMONSTRATION	\$500K
12	28TH STREET STORM DRAIN INFILTRATION	\$17.6M
13	AGOURA HILLS COUNTY YARD TREATMENT	\$4.6M
14	GARVEY AVENUE GRADE SEPARATION	\$4M
15	WINGATE PARK REGIONAL EWMP	\$24M

We are deeply familiar with the challenges and constraints of working on grant-funded projects such as grant-related reporting and coordination, operating on strict and condensed timelines, and staying within stringent budget limitations. We understand the necessity of accurate cost estimation to stay within grant limitations and design our projects with future operations and maintenance costs in mind. CWE’s primary goal for this engineering services contract is to deliver successful CIP projects that will benefit the City and residents of Moreno Valley. CWE believes each completed milestone at any phase in the project at-hand will result in a people-friendly infrastructure providing vibrant and inviting public spaces that will engage neighborhoods to be active in their community.

2.2 Program Management Quality Assurance/Quality Control

The work performed by the CWE team will be conducted using our thorough, proven Quality Management Process (QMP). The QMP ensures that quality work products and services are delivered to our clients on a consistent basis. The QMP is the essential foundation for the execution of any CWE project, and it consists of two parts: Quality Assurance and Quality Control.

Attachment: Agreement with CWE (6330 : AUTHORIZATION TO AWARD AGREEMENTS FOR PROFESSIONAL CONSULTING SENIOR





City of Moreno Valley
 Consultant Senior Engineer Services

- **Quality Assurance** consists of the written procedures that drive quality. Specific procedures start with a joint City and CWE project kick-off meeting to verify that everyone understands the intent, objectives, tasks, budgets, schedules, milestones, and deliverables; the kick-off meeting also identifies responsible individuals for implementing work tasks. The QA procedures also require a standardized checking process, including technical reviews.
- **Quality Control** is the system for verifying that the quality assurance procedures are actually being implemented. Quality control activities are the actual checking and validation of the work product at every stage of its development. These critical activities include internal quality control reviews by senior experts; they also include a rigorous cross-checking process for making sure that comments, revisions or corrections to any deliverable are correctly completed. This same checking process will also be used to document actions taken for comments made by County reviewers.

Our QA/QC procedures will be based on CWE's QMP and the City's standards and preferences. To maintain consistency, CWE team members will be required to comply with the QMP requirements in addition to their own established procedures. The written QMP will be project-specific and meet both City and CWE quality standards and procedures. CWE will incorporate the City's QA/QC procedures into the QMP including the development of QA/QC checklists, discipline and interdisciplinary checks, and calculation checks. Incorporating County procedures into CWE's quality procedures results in a high-quality project that the City Project Manager can easily review for compliance. Based on the QMP, the QA/QC design reviews will include, at a minimum, the following:

- Pre-Design Review
- Design Reviews
- Value Engineering
- Construction Reviews
- O&M Reviews
- Utility Coordination
- Ready to Advertise Checklist

The QMP will establish the necessary processes to accomplish the following:

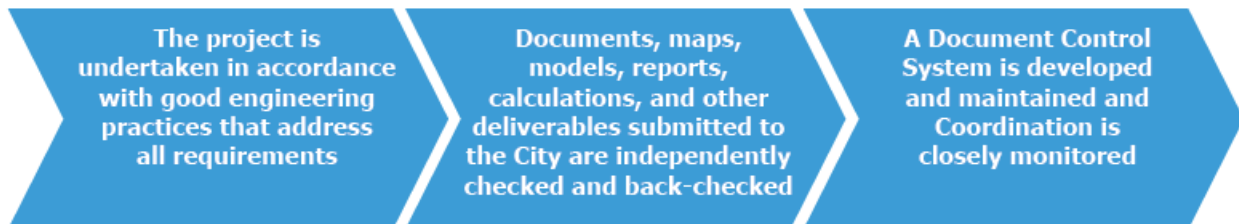

Bill Young, PE will be assigned as the **QA/QC Manager** for this contract. He will be responsible for performing quality control checks and managing the independent peer review process of completed deliverables. With over 40 years of public agency engineering experience, he has the background and expertise to make sure submittals are accurate, complete, and in compliance with the required standards.

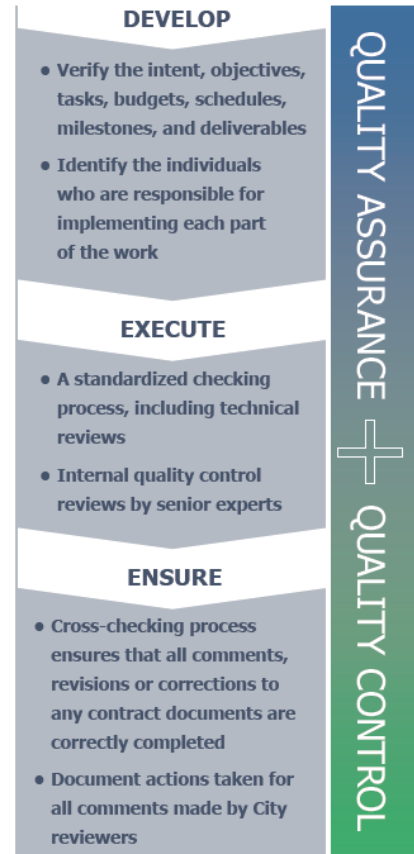

Attachment: Agreement with CWE (6330 : AUTHORIZATION TO AWARD AGREEMENTS FOR PROFESSIONAL CONSULTING SENIOR





2.3 Related Experience

Moreno Valley NPDES Consulting and WQMP Plan Check Project Description



CWE is providing on-call stormwater management services to ensure compliance with the Riverside County Municipal NPDES Stormwater Permit, Construction General Permit (CGP), and bacteria and nutrient TMDLs for the Santa Ana River Watershed, and have assisted the City with a program audit performed by the Santa Ana Regional Water Quality Control Board (RWQCB). CWE has performed more than 250 plan check reviews of Preliminary and Final WQMPs associated with new development and significant redevelopment projects, program management, regulatory support, public education,

preparation of stormwater guidance materials, stormwater compliance inspections, municipal staff training, and review and recommendation of modifications to the City’s standard plans, details, codes, and ordinances to ensure compliance.

CWE has performed plan checking services on WQMPs for the City of Moreno Valley since 2010. CWE receives both preliminary and final WQMPs from developers and performs review services per the NPDES MS4 Permit, Riverside County Low Impact Development (LID) Best Management Practices (BMP) Design Manual and the Guidance Manual. The task involves careful inspection of submitted documents, thorough knowledge of the relevant local ordinances, and frequent communications with developers and with City planning and engineering staff members. Redlined plans, documents, a review checklist, and a comment letter are prepared and returned to the developer if changes are needed within 10 days, and CWE has never missed a deadline over the last nine years and hundreds of plan checks.

Date: December 2011-Present
Name of agency: City of Moreno Valley
Reference name/contact information: Hoang Nguyen, Associate Engineer, hoangn@moval.org , (951) 413-3216

San Bernardino County Stormwater Resource Plan



CWE prepared a Stormwater Resource Plan (SWRP) for the Santa Ana River Watershed portion of San Bernardino County based on the SWRP Guidelines developed by the SWRCB and grant agreement terms. CWE prepared a grant application for the SBCFCD, which resulted in an award of \$475,000 to develop an SWRP through the Proposition 1 Planning Grant Program. The SWRP provides water quality data assessment, review of existing and development of new tools and models to quantitatively assess projects with a goal of achieving water

quality objectives, assessment and prioritization of projects providing multiple benefits (such as water quality, water supply, flood management, environmental, and community benefits), monitoring to support future implementation, an implementation schedule, and public and stakeholder involvement. CWE provided project management, established a Technical Advisory Committee (TAC), performed data





City of Moreno Valley
 Consultant Senior Engineer Services

collection and watershed identification, developed the SWRP, and facilitated stakeholder/public outreach and education. Tasks included identifying watershed scope and characteristics, such as land use, soil types, rainfall depths, and runoff patterns; identifying water quality priorities to guide implementation efforts; identifying and prioritizing potential water-related projects; performing metrics-based analyses to quantify project benefits, including modeling, calculations, pollutant mass balances, and other analysis methods; preparing education and outreach materials; and coordinating stakeholder/public outreach and education events.

Date: January 2017-January 2019
Name of agency: San Bernardino County Department of Public Works
Contact name/information: Arlene Chun Stormwater Program Manager, arlene.chun@dpw.sbcounty.gov

LA County Public Works Project Management Services

Since 2017, CWE has executed a diverse range of Capital Improvement Projects for Public Works, including highway, traffic, and drainage design, hydrologic calculations, materials engineering, mapping, utility coordination, and construction support. Projects encompassed pavement and flood control rehab, congestion relief, roadway widenings, grade separations, ADA compliance, roundabouts, lighting studies, traffic analysis, slide stabilization, guardrails, culvert upgrades, parkway improvements, intelligent transportation, traffic safety, and pedestrian access enhancements. Relevant service areas include highway and bridge design, traffic design, water resources design, hydrologic and flood control facility, and project management.

Date: October 2022
Name of agency: LA County Public Works
Contact name/information: Wendy Bui, Senior Civil Engineer, wbui@dpw.lacounty.org , (626) 300-4593

City of Los Angeles Laurel Canyon Boulevard Green Street Design-Build

This project received awards from the American Society of Civil Engineers (ASCE) Los Angeles Section, ASCE Metropolitan Los Angeles Branch (MLAB), and California Stormwater Quality Association (CASQA). CWE designed and performed construction management for roadway widening; curb, gutter, and sidewalk improvements; and over 2,100 square feet of bioretention systems and 13 fifty-foot-deep drywells along 1,000 linear feet of Laurel Canyon Boulevard for LA Sanitation – City of Los Angeles and the Los Angeles Conservation Corps. The project provided increased groundwater recharge, reduced flooding impacts, enhanced water quality, protected compatible beneficial uses, and improved the neighborhood quality of life. To accomplish this, CWE implemented CU-Structural Soil™ (CU Soil), which accommodates increased water storage in the bioswales, and therefore increases infiltration. This project will collect approximately 13 million gallons of stormwater runoff from a 125-acre drainage area and recharge the San Fernando Groundwater Basin. An additional 20 feet was added to the width of the street to accommodate Americans with Disabilities Act (ADA)-compliant curb ramps and sidewalks on the eastern side of Laurel Canyon Boulevard, which not only benefitted traffic flow and improved congestion during school hours and rush-hour traffic, but also reduced flooding on the streets and mitigated ponding





City of Moreno Valley
 Consultant Senior Engineer Services

at residential driveways and intersections after storm events. The project required considerable coordination with residents who voluntarily dedicated a portion of land across the width of the front of their property, the Los Angeles Bureau of Sanitation, Los Angeles Department of Water and Power (LADWP), Los Angeles Department of Transportation, Los Angeles Conservation Corps, and Los Angeles City Councilmember Felipe Fuentes, 7th District. CWE provided pre-, during, and post-construction support for this project.

Date: June 2014-May 2017
Name of agency: LA Sanitation – City of Los Angeles
Contact name/information: Wing Tam, Assistant Division Manager, wing.tam@lacity.org , (213) 485-3985

City of Torrance Beach Cities Green Streets



CWE is providing design services for the development of green streets in the Beach Cities of Torrance, Redondo Beach, Hermosa Beach, and Manhattan Beach to capture runoff generated from the 85th percentile storm event so that it doesn't reach the surf zone, as identified in the Beach Cities Enhanced Watershed Management Plan (EWMP). The project will collect stormwater from over 200 acres that generate runoff, reduce the volume of runoff, and filter out trash from entering the Herondo and 28th Street storm drains from the four Beach Cities. CWE is designing a variety of Best Management Practices (BMPs) including porous pavement; catch basin trash screens; biofiltration/bioretention systems; natural systems such as vegetated curb extensions, planters, swales, and rain gardens; and drywells to intercept, filter, and retain runoff between various locations. This project addresses water quality issues in the Santa Monica Bay, including Total

Maximum Daily Loads (TMDLs) for dry- and wet-weather bacteria, nearshore and offshore debris, and toxic chemicals such as dichlorodiphenyltrichloroethane (DDT) and polychlorinated biphenyl (PCB) that often result in beach closures. Tasks include project management; preliminary and final design Plans, Specifications, and Estimates (PS&Es); research, data collection, and analysis of utility and street plans, Geographic Information System (GIS) data, Beach Cities Reasonable Assurance Analysis (RAA) and Coordinated Integrated Monitoring Plan (CIMP) data, City-specific templates and plan sets, and stakeholder organizations; community outreach; geotechnical exploration; topographic survey; utility search and potholing; hydrologic analyses; permitting and preparing an Initial Study/Mitigated Negative Declaration (IS/MND) in accordance with the California Environmental Quality Act (CEQA); dry- and wet-weather monitoring and maintenance that includes a Monitoring and Reporting Program (MRP) and Quality Assurance Project Plan (QAPP); and providing engineering support during bid and construction phases.

Date: September 2020-September 2023
Name of agency: City of Torrance
Contact name/information: John Dettle, Former Engineering Manager, John.dettle@surfcity-hb.org (714) 343-0968





City of Moreno Valley
 Consultant Senior Engineer Services

City of Los Angeles Bureau of Engineering (BOE) Task Order Solicitation (TOS) 10 – Connecting San Pedro Multi-Modal Project

This Project aims to create a Complete Street environment with **VisionZero** at its heart to improve accessibility and safety in an area known to have a high number of collisions. CWE is developing civil plans which include sidewalk and roadway improvements, bus extensions, curb extensions, curb ramps, drainage features, and composite substructure and overhead utilities.

Improvements in the Project area encourage increased walking, biking, and public transit use, and provided better access to civil amenities

in the area such as the San Pedro Library Branch, Harbor Boulevard Parkway, schools/learning centers, markets, and more. Improvements are focused on 1st Street and 7th Street between Gaffey Street and Harbor Boulevard, along with the intersection of 10th Street and Gaffey Street. Curb ramps are being designed with new curb extensions to meet Americans with Disabilities Act (ADA) requirements as well as achieve traffic calming, Low Impact Development (LID), and improved safety. Project scope includes twelve intersections, one signal improvement, more than 70 curb ramps, and bus extensions to benefit four different bus operators (Metro, DASH, Commuter Express, and PVPTA). Design support during bid, award, and construction phases is also being provided.

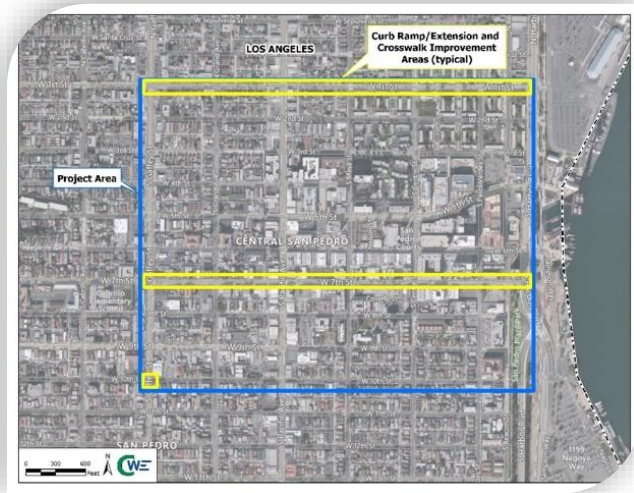

Date: April 2021-Present
Name of agency: City of Los Angeles Bureau of Engineering
Contact name/information: Fadi Abboud, Civil Engineer, Fadi.Abboud@lacity.org , 213-482-7477

City of Temecula Flood Control Channel Reconstruction and Repair

CWE prepared environmental services and designed reconstruction and repairs to flood control channels adjacent to or running through Pala Community Park, Margarita Community Park, and Long Canyon Creek Park. Tasks included: reviewing project plans and investigative reports, performing site review of existing facilities, hydrologic and hydraulic analysis of the creek systems, determining appropriate and cost-effective methods and materials to solve flood control channel erosion issues, preparing cost estimates, preparing schematic design of the preferred improvements chosen by the City, and seeking review and comment on the schematic design from resource agencies.



The second phase of the project involves developing plans, specifications, and cost estimates; assessing jurisdictional delineation; evaluating environmentally sensitive areas and potential species that could be impacted; coordinating work with local native tribes; coordinating the geotechnical investigation; and preparing permit packages





City of Moreno Valley
 Consultant Senior Engineer Services

for approval by regulatory agencies. CWE prepared an IS/MND for aesthetics, agriculture and forest resources, air quality, biological resources, cultural resources, tribal cultural resources, paleontological resources, geology and soils, greenhouse gas emissions, hazards and hazardous materials, hydrology and water quality, land use and planning, mineral resources, noise, population and housing, public services, recreation, transportation/traffic, and utilities and service systems. The IS/MND determined less than significant to no impact to all aspects of this phase.

Date: March 2014-December 2019
Name of agency: City of Temecula
Contact name/information: Nino Abad, Associate Civil Engineer, nino.abad@temeculaca.gov , (951) 308-6385

San Bernardino Valley Water Conservation District Debris Management Improvement and Design for Mill Creek Diversion

CWE designed a modified diversion system that redirects debris and sediment while allowing flows to be routed to the existing spreading grounds. The project involved hydraulic modeling; PS&Es development; and permitting support for the development of an improved water diversion system for the Mill Creek spreading basins to reduce and prevent debris from accumulating at the diversion gate. Tasks included: developing project concepts, schematic design drawings, and preliminary cost estimates for three alternative concepts; evaluating the performance and maintenance characteristics of the conceptual alternatives; determining the most cost-effective and maintainable design for the diversion system; analyzing existing conditions for flow depths, velocities, debris accumulation, and long-term channel sedimentation trends; calculating the hydrostatic, hydrodynamic, and debris impact loads for the 5-, 10-, 25-, 50-, and 100-year storms; and identifying required permits.

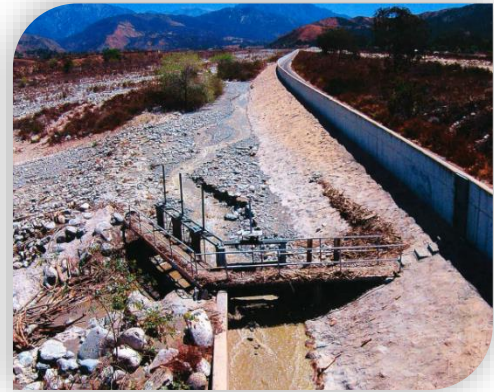

Date: May 2015-present
Name of agency: San Bernardino Valley Water Conservation District
Contact name/information: Erwin Ferguson, Project Manager, efogerson@sbvwcd.org , (909)-793-2503

2.4 Staffing and Resource Management Plan

The Staffing and Resource Management Plan was the first item we evaluated as we developed our team. It is crucial to provide the right resources for each task that we take on and are able to provide the right resources to get the work completed efficiently. CWE is committed to providing the necessary resources for work anticipated under this contract. Collectively, we have over 57 personnel that can assist the City in any needed capacity.

Attachment: Agreement with CWE (6330 : AUTHORIZATION TO AWARD AGREEMENTS FOR PROFESSIONAL CONSULTING SENIOR





City of Moreno Valley
 Consultant Senior Engineer Services

We have a core group of over 50 professionals and technical staff that are available and will primarily be responsible for the timely delivery of work to the City. These folks are dedicated to delivering the work products per the schedule for each of the task orders.

We resource load all of our work needs in our proprietary scheduling system. We specifically review our workload over the next four month look ahead schedule and forecast resource needs and demands. Our Project Managers meet weekly to discuss any changes and anticipated needs from clients. This allows us the flexibility to allocate internal resources or use our teaming partner’s resources for any upcoming needs. As we have a deep bench of resources that are at a minimum double stacked between firms for the work needs requested by the City, we can fulfill any needs that may arise under this contract.

The CWE team is available to assist the City on an emergency response basis. City staff is encouraged to contact our task leads directly in those emergency cases to ensure we deliver on the County’s requests right away.

Farooq Qureshi, MBA, our proposed **Resource Manager**, will fill those roles in consultation with our leads and the City. Our On-Site Senior Engineer lead will serve as a single point of contact for the City. By maintaining a single point of contact, the City will receive a consistent and single voice over all project tasks.

Resource Allocation and Availability

We are committed to assigning the personnel shown in our organizational chart presented in the next section. **Alex Torres, PE QSD/P** will be our designated **On-Site Senior Engineer** to support the City. Alex will serve as the single point of contact for these services, but will be supported by our Principal, Vik Bapna, PE, and **Resource Manager, Farooq Qureshi, MBA, ENV SP**. Vik and Farooq will fill resources in consultation with the City Subject Matter Experts and support personnel will be available from our home office as-needed. At no time shall CWE replace or remove personnel without explicit approval and/or discussions with the City. We anticipate our staff availability for this project as follows:

Name	Role	Year 1	Year 2	Year 3
CWE Key Staff Availability				
Alex Torres, PE, QSD/P	Senior Engineer (On-Site)	100%	100%	100%
Steven Bell, PE, ENV SP, CFM, QSD*	Technical / Management Support	50%	65%	80%
Katie Harrell, PE, ENV SP, QSD*	Technical / Management Support	50%	65%	80%
Larry Tortuya, PE, ENV SP, CFM, QSD/P*	Technical / Management Support	50%	65%	80%
Bill Young, PE	Technical / QA-QC / Management Support	40%	70%	90%
Vik Bapna, PE, ENV SP, CPSWQ, QSD/P,	Principal-In-Charge	10%	20%	30%
Farooq Qureshi, MBA, ENV SP	Resource Manager	10%	20%	30%
Mike Nguyen	Technical Support	40%	60%	80%
Lien Tran, EIT	Technical Support	40%	60%	80%
Angelique Silvestre, EIT, ENV SP	Technical Support	40%	60%	80%

* Personnel identified as "backup up" personnel for the identified Senior Engineer role.

Attachment: Agreement with CWE (6330 : AUTHORIZATION TO AWARD AGREEMENTS FOR PROFESSIONAL CONSULTING SENIOR





3. Proposed Staff/Team

Our proposed team has robust experience furnishing capital improvement projects to municipal clients with distinction. For over 20 years, the leadership team at CWE has been managing and deploying staff augmentation personnel for public agency clients and garnering recognition from reputable organizations such as ASCE, CASQA, and APWA. We are intimately familiar with providing civil engineering services to public agencies including design, planning, engineering calculations and modeling, roadway reconstruction, widening, and realignment; pavement improvement, bridge replacement, pedestrian facility upgrades, Americans with Disabilities Act (ADA) compliance, drainage improvements, retaining wall repair and construction; and water/sewer system planning, modeling, and design. Our team includes 5 Professional Engineers as well as engineers-in-training (EIT), CAD drafters; Qualified SWPPP Developers and Practitioners (QSD/Ps); Geographic Information System (GIS) specialists; and Envision™ Sustainability Professionals (ENV SP). To ensure thorough streamlined project delivery, our team will consistently maintain close, collaborative relationships with City staff.

Organizational Chart

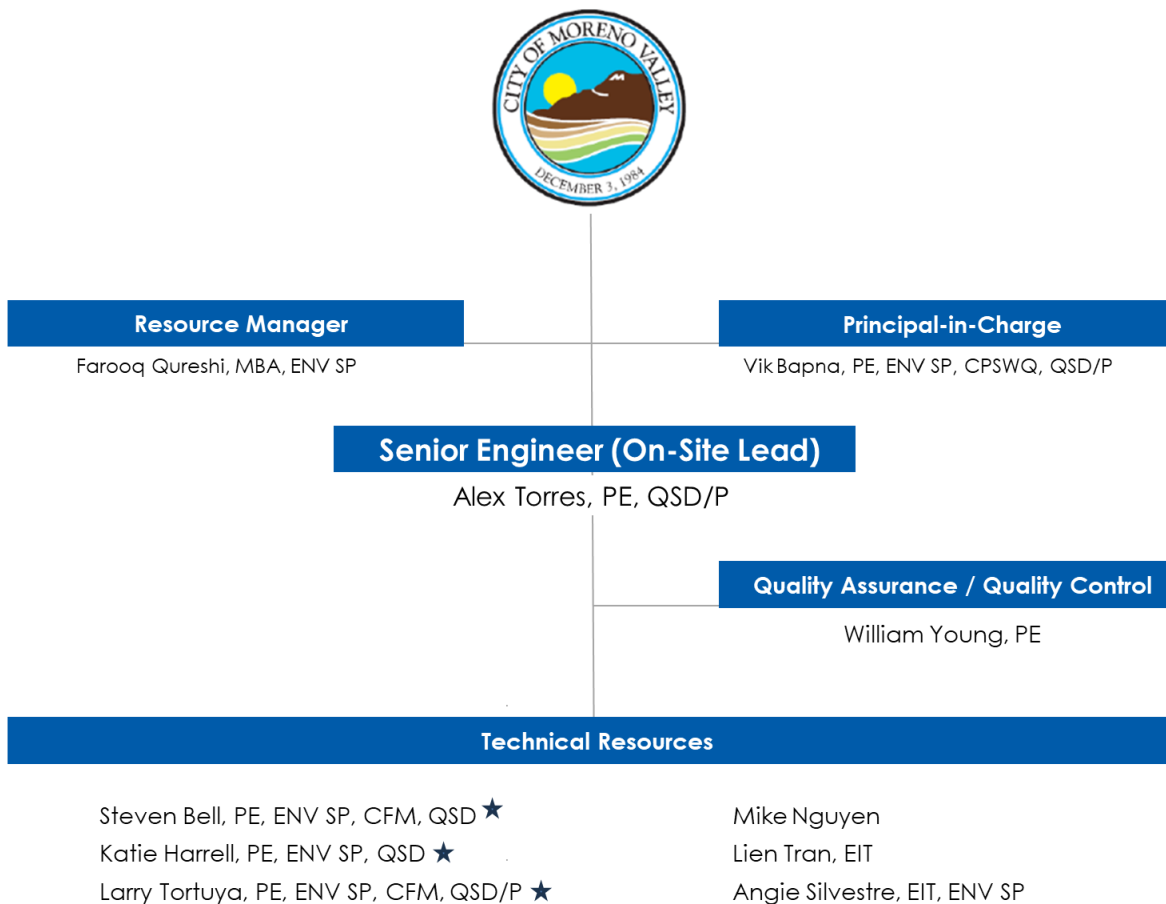

★ Denotes personnel available as "Back-Up" to the Senior Engineer





3.1 Meet Your Senior Engineer

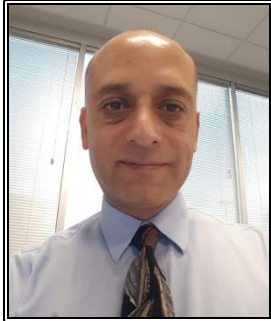

Alex Torres, PE, QSD/P, is CWE's designated Senior Engineer. He is committed to dedicate 20 to 40 hours a week, or as much effort as the City requires, as part of this Staff Augmentation request for Senior Engineer services. Over the last 11 years, Alex has been managing civil engineering projects for government agencies and municipalities in

Southern California, in addition to 21 years of technical experience in a broad range of civil engineering projects and services that heavily involved infrastructure, transportation, water resources, stormwater quality, traffic design, site

grading, sewer and water design, dry utility coordination, project management, construction support, and strategic communications. He has extensive experience coordinating large project teams to deliver over \$1 billion worth of comprehensive civil engineering and water-related projects to various public agency clients throughout Southern California, most of which includes city, county, state (Caltrans and DWR), special districts (WMWD, EMWD, EVMWD), and the City of Moreno Valley.

In recent times, Alex worked on the recently completed SR-60/World Logistics Center (WLC) Interchange, the ongoing Sunnymead Master Drainage Plan (Lines F and F-7) and the Moreno Master Drainage Plan Line F-18 and F-19. On the SR-60/WLC project, Alex successfully managed the traffic study and was the project engineer signing the Project Approval/Environmental Document (PA/ED) Stormwater Data Report (SWDR) which documented 116.4 acres of disturbed soil area (DSA) and 10.1 acres of new impervious area (NNI). 100% of the NNI is treated by infiltration basins and biofiltration swales totaling \$4M in constructions. The Report included cost estimates for Design Pollution Prevention BMPs (\$500,000) and Temporary Construction BMPs (\$625,000). On the Sunnymead and Moreno Master Drainage Plans, Alex was the lead drainage engineer for developing workplans and workflows for the analysis and design of the drainage facilities which included inlets/catch basins, storm drains, surface channels, and detention basins. He led and mentored three junior level engineers to assist with analysis, plan, production, and cost estimates.

Prior to these projects with the City, Alex worked as Senior Project Engineer for a Staff Augmentation Project with Caltrans District 8 from 2015 to 2017. His role was a Senior Project Engineer responsible for working on projects in the PA/ED and PS&E phases. He was Engineer of Record on the drainage plans, stormwater data report (SWDR) and drainage report for Cedar/I-10 Interchange in Bloomington, SR-395 in Adelanto from SR-18 to Kern County line, I-40 Culvert Extensions, Mt Vernon/I-215 Interchange in Colton, SR-74 Median in Hemet, and a storm drain relocation project on HWY 330 near Big Bear. Aside from drainage projects, Alex was tasked to author the Project Report for the SR-62 Median project in the Morongo Valley. The project report is required during the PA/ED phase of any Caltrans project to document the purpose and need of the project and to show approval from the Caltrans Functional Units that the project has met requirements to move to the PS&E Phase. This project report listed three

Why Alex?

- 21 years of cumulative experience, all in Public Works/CIP Projects
- Project Management experience over the last 11 years on over 30 relevant civil engineering projects
- Over 2 Years of On-Site Staff Augmentation Experience
- Plan, prepare, direct, manage deliverables and staff
- Federal, state, and local laws, regulations
- Effective Communicator
- Local to Moreno Valley



City of Moreno Valley
Consultant Senior Engineer Services

alternatives on the draft submittal for a median barrier to be installed on SR-62 from the I-10 to Yucca Valley and the purpose was for the barriers to reduce collisions on this two-lane highway. Alex ensured this report was approved by the Milestone goal Caltrans had programmed. Throughout this staff support services contract, Alex was instrumental in coordinating with the Functional Units including Environmental, Landscape, Structures, Geotechnical, Traffic Operations, Project Management, and Construction.

CWE understands that the majority of CIP projects for the City are street and drainage projects while others are for traffic improvements and multimodal bicycle and pedestrian routes. We consider Alex a highly qualified candidate to successfully lead this three-year program due to his well-rounded experience.

For further details on Alex's experience (including references), please refer to his resume at the end of this section.

Other Technical, Management, and Support Personnel

Alex will be supported by a team with hundreds of years of experience working in public infrastructure project engineering and management. Detailed personnel resumes are included at the end of this section.



Steven Bell, PE, ENV SP, CFM, QSD has 17 years of specialized experience in civil design, project management and technical advising, and water resources engineering. His impressive list of certifications includes a Professional Engineer since 2011, an Envision™ Sustainability Professional since 2019, a Certified Floodplain Manager since 2019, and Qualified Stormwater Pollution Prevention Plan (SWPPP) Developer (QSD) in California since 2017. These certifications reflect his commitment to sustainable infrastructure development. Steven is well-versed in numerous hydrologic, hydraulic, sediment transport, distribution, and water quality models including EPA-SWMM, EPANET, HEC-HMS, HEC-RAS, HEC-SSP, MODRAT, XP-SWMM, and XP-WSPG. These skills will be invaluable for capital improvement projects requiring precise processes, cost estimates, and compliance with regulations.



Katie Harrel, PE, ENV SP, QSD is a talented engineer with 11 years of experience in the management, feasibility assessment, and design of award-winning BMP projects. She effectively coordinates with clients, permittees, subconsultants, and project staff to ensure project completion on strict budgets and deadlines. Her duties have included developing master planning concepts, designing urban runoff treatment and control facilities, preparing pollution prevention assessments and reports, performing stormwater compliance inspections, performing water quality monitoring, conducting hydrology and hydraulic studies, modeling hydrology and hydraulic conditions, conducting utility research, traffic control planning, and obtaining required permitting. She has extensive experience coordinating with project staff to ensure project completion.



In addition, Katie has extensive experience assisting public agencies with complex grant applications as high as \$17 million.



Larry Tortuya PE, ENV SP, CFM, QSD/P has been providing comprehensive stormwater management engineering services and similar services throughout the state of California for more than two decades. He has worked as part of a collaborative design team creating storm drain master plans, PS&Es, floodplain management studies, and writing hydrology and hydraulics reports for both the public and private sectors. Larry is responsible for the planning, execution, and coordination of the design of stormwater-related improvements including grading, traffic control, water quality design, and construction support. His proficiency in modeling programs including XP-SWMM, AES, HS8, HEC-RAS, HEC-1, HEC-12, Visual Urban, Flow Master, WSPG/W, MORA, Storm, ArcGIS, AutoCAD Civil 3D, and Micro-station position him as an expert in cost-effective project execution.



Bill Young, PE is a respected leader in the California civil engineering community, with more than 40 years of experience managing large and small design projects from conceptualization and design through construction. Bill's experience covers a diverse range of community improvement projects involving parking lot, street, curb, and gutter repairs and improvements; highway design; flood control infrastructure; and irrigation lines. He also has experience obtaining necessary permits for these projects. His substantial background in pavement rehabilitation design including pervious pavement and interlocking pavers; bioswales and bioretention systems; stormwater BMPs, and irrigation lines demonstrates his aptitude for performing the precise plans, cost estimates, and regulatory approvals of CIPs.



Vik Bapna, PE, ENV SP, CPSWQ, QSD/P is an award-winning civil engineer with 32 years of experience in the planning, design, and construction of more than \$1 billion worth of civil engineering projects, ranging from single-lot developments to regional stormwater best management practice (BMP) projects with multiple stakeholders. His experience includes developing multi-benefit water quality enhancement projects, developing multiuse projects to infiltrate urban and stormwater runoff, designing structural treatment control BMPs, and developing project concepts. Vik was responsible for developing the first urban watershed plan that addressed flood protection, water quality enhancements, creation of open space and recreational opportunities, and habitat enhancements. His extensive experience covering work programs, multistakeholder coordination, and regulatory approvals aligns seamlessly with capital improvement projects.





City of Moreno Valley
Consultant Senior Engineer Services



Farooq Qureshi, MBA, ENV SP has over 20 years of experience in delivering public multidisciplinary projects, and is well versed in the contract administration of large and small engineering staff augmentation contracts. He has administered and supported over \$25M and 100+ resource personnel for City of Los Angeles Bureau of Engineering, County of Los Angeles Department of Public Works, NAVFAC and USACE on numerous task orders, including recruitment, placement, proposals, modifications, estimates, negotiations, cost/task tracking, purchasing, and stakeholder buy-in. He has expertise in quality assurance/control (QA/QC), data management, best management practices (BMPs), engineering controls, and integrating hardware and software solutions for A-E projects. Farooq's time overseeing this contract will not be charged to the City.



Mike Nguyen has 16 years of civil engineering experience involving design, public works construction, and land development projects. His recent experience includes managing capital improvement projects as well as PS&E and traffic control plan preparation for public works projects, including parking lot, street, water supply, park, and median improvement projects. Mike also provides design for grading and drainage, street and highway design, LID, geometric layout, and pavement rehabilitation, which will be of great value in the planning, cost estimation and bid document completion for the City.



Lien Tran, EIT has over 20 years of experience preparing numerous conceptual and construction documents of stormwater, water, and wastewater projects that include pipeline plan and profile, channel and basin design, construction details and sections, traffic and erosion control plans, and right-of-way (ROW) acquisition drawings. She has experience preparing grading, street, sewer, water, and storm drain improvement plans for residential and public works projects while adhering to design standards, agency processing requirements, and client expectations. Lien also prepares hydrologic/hydraulic calculations and cost estimates related to capital improvement projects. She is proficient in Civil3D, MicroStation, ArcGIS, WSPGS, FlowMaster, HEC-RAS, BlueBeam, and Global Mapper.



Angelique Silvestre, EIT, ENV SP has broad experience completing roadway, utility, geometry, subdivision, site development grading, drainage, sewer, water, and storm drain projects. She has a proven track record in producing PS&Es for public and private clients in Southern California, including but not limited to traffic control, fiber optics, striping, and temporary street lighting plans and specifications for the installation, removal, and replacement of traffic signs, markings, protective structures and street lights, and temporary traffic control plans. She also collects and analyzes traffic data related to traffic hazards, accidents, volume, flow speed, direction, circulation, and road capacity. Additional experience includes providing CAD support, geotechnical engineering, understanding of NPDES requirements and preparation of erosion control plans, BMP reports for WQMPs, SUSMPs, and LID Plans.



City of Moreno Valley
Consultant Senior Engineer Services



Alex R. Torres

PE, QSD

Senior Engineer (On-Site Lead)

RELEVANT EXPERIENCE

City of Moreno Valley, Sunnymead Storm Drain Project

Lead Engineer authoring the drainage report that demonstrates proposed drainage facilities downstream of Sunnymead Boulevard safely convey the 100-year storm onto a Riverside County Flood Control and Water Conservation District (RCFC&WCD) concrete-lined trapezoidal channel, identified as Line "F" in the Sunnymead Master Drainage Plan (MDP). These improvements alleviate flooding from Hemlock Boulevard/Graham Street intersection and the Towngate Apartments north of SR-60. A series of drainage improvements were designed upstream of the proposed SMART basin South of Sunnymead Boulevard. This basin reduces the peak flow from 611 cubic feet per second (cfs) to 415 cfs while allowing a low-flow of 110 cfs to bypass the basin through natural swale down to a confluence from the outflow of the proposed Sunny Meadows Drive Basin. This flow then enters Line "F" and contains an additional foot of freeboard.

City of Moreno Valley and Caltrans District 8, SR-60 / World Logistics Parkway Interchange

Project Engineer producing the Stormwater Data Report (SWDR) aimed at enhancing traffic flow within the World Logistics Center by reconfiguring this interchange. The SWDR accounted for 116.4 acres of disturbed soil area (DSA) and 10.1 acres of new impervious area (NNI). 100% of the NNI is treated by infiltration basins and biofiltration swales totaling \$4M in construction. Report included cost estimates of Design Pollution Prevention BMPs (\$500,000) and Temporary Construction BMPs (\$625,000). Alex had a dual role in managing the traffic study for this project.

RCFC & WCD, Woodcrest Dam Outlet Project Engineer who performed culvert analysis supporting the upgrade of the intake structure of the 30" RCP culvert underneath the 67-year-old dam. Verified culvert rating (stage-discharge) curve calculations provided by RCFC&WCD were accurate and advanced to a 60% design level reflecting the latest outlet structure design by WSP. Concluded the governing



Years of Experience

21

Years with CWE

1

Education

B.S., Civil Engineering, Cal Poly Pomona, 2002

Registrations

Professional Engineer (Civil), CA, 78892

QSD, BPELS, CA, 2018

References

Quang Nguyen, P.E.
Capital Projects Principal Engineer
City of Moreno Valley Public Works
quang@moval.org
951-413-3159

Edwin Quinones
Watershed Protection Division Chief
Riverside County Flood Control and Water Conservation District
eequinon@rcvco.org
951-955-1265





City of Moreno Valley
Consultant Senior Engineer Services

outlet rating curve is under Inlet-Control Orifice. In addition, provided recommendations desilting upstream of the intake structure.

RCFC & WCD, Phoenix Storm Dain Stormwater Diversion Project Engineer who provided planning level analysis and recommendations for diverting dry-weather flows mainly consisting of irrigation water high in indicator bacteria to nearby sanitary sewer maintained by the City of Riverside. Recommended a SCADA controlled wet well (lift station) calibrated to pump dry-weather flows to sewer while stormwater was routed to Phoenix Storm Drain upstream of the Santa Ana River.

LA Metro Division 11, Drainage Improvements Adjacent to Universal Warehouse Project Manager who conducted site improvement consisting of proposed drainage facilities and permanent BMPs to address flooding and ponding issues at Metro Yard located on 208th Street in Carson. The project deliverables include PS&E and a hydrology and hydraulics study. Acted as Task Manager for Drainage Discipline on this design-build project.

Caltrans District 8, SR-62 Median Barrier Installation Project Manager providing design services for this Caltrans SHOPP project as part of an On-Call Agreement with the State of California, Department of Transportation (Caltrans), Caltrans Design Unit. The project scope entails design of raised curb median and double three beam barrier and coordination with various Caltrans functional units and the City of Morongo Valley. Tasks included compiling the Project Report (PR), PAED cost estimate, and short form Storm Water Data Report (SWDR) during the PA/ED phase. During the PS&E phase, provided assistance in the SWDR and Water Pollution Control estimates and specifications.

Caltrans District 8, I-40 Median Cross-Slopes Regrading Project Engineer providing design services for this Caltrans SHOPP project as part of an On-Call Agreement with the State of California, Department of Transportation (Caltrans), Caltrans Design Unit. Responsible for over 200 drainage systems mainly consisting of culvert extensions and installing drainage facilities. Tasks included hydraulic calculations, plan preparation, quantity take-offs, construction cost estimate, and slope staking notes for surveyor.

Caltrans District 8, I-15 Cajon Pass Pavement Rehabilitation Drainage Lead for this design-build project that rehabilitated the existing I-15 freeway from 0.4 miles north of Kenwood Avenue to 0.3 miles south of West Hesperia Overhead. The roadway rehabilitation work includes repairing the existing Portland Cement Concrete Pavement by replacing two outer lanes, asphalt concrete shoulders, and asphalt concrete patched areas with 40-year rigid pavement design. Performed design of drainage facilities and temporary water pollution control drawings. Also responsible for drainage investigation and attended focus meetings weekly and coordinated with JV partner for turnkey solutions. While the project was in construction, provides responses to any RFIs related to drainage design.

Riverside County Transportation Commission, SR-91 / SR-71 Interchange Project Drainage Lead for this project with a scope entailing PS&E, ROW, and utility coordination; including coordination with USACE, Chino Hills State Park, multiple resource agencies, Caltrans, and other local stakeholders. Record Engineer for drainage systems design and hydrology and hydraulics analysis. Delegated tasks to other staff and coordinated with other design disciplines and managers. Compiled structures hydraulics report which included deck drain design and Scour analysis via HEC-RAS.

Riverside County Transportation Department, Butterfield Stage Road Extension Project Engineer leading the drainage efforts involving H&H (hydrology/hydraulic) Study, WQMP(Water Quality Management Plan), and flood plain risk assessment of Tualota Creek where it crosses the proposed roadway alignment. Coordinated with RCFC&WCD to obtain the existing study of Tualota Creek that



City of Moreno Valley
Consultant Senior Engineer Services

would provide 100-year flood elevations at the roadway crossing. This project involved a bridge crossing over Tocalota Creek that would not alter the 100-year floodplain. Other tasks consist of addressing Hydrologic Conditions of Concern (HCOC's) by designing detention basins to attenuate 2-year and 10-year, 24-hour design storms to existing conditions.

San Bernardino County Transportation Authority (SBCTA), Redlands Passenger Rail Project (RPRP) Line, San Bernardino to Redlands Project Manager who reviewed the SWPPP and temporary water pollution control plans for SBCTA's RPRP. In addition, he also reviewed the Permit Registration Documents (PRDs) and risk assessment. The RPRP is an advanced regional transportation project designed to connect residents, businesses, and visitors to a variety of leisure, education, healthcare, and other destinations. This nine-mile rail project provides new transportation choices through the implementation of a new rail service that integrates conveniently with other modes such as auto, bus and bicycle.

Riverside County Transportation Commission (RCTC), I-215 South Connector Project, Murrieta, California Lead Engineer for this project that widened a six-mile section of I-215 from Murrieta Hot Springs Road to Scott Road in Menifee. One lane and a shoulder were added within the existing freeway median, creating three northbound lanes and three southbound lanes. In addition, Keller Road Undercrossing was widened by adding a median barrier. The existing pavement was repaired, and the freeway grading and drainage was adjusted. Alex compiled conceptual drainage design, preliminary drainage studies, and Storm Water Data Report (SWDR) for the PA/ED phase of this project.

Attachment: Agreement with CWE (6330 : AUTHORIZATION TO AWARD AGREEMENTS FOR PROFESSIONAL CONSULTING SENIOR





Steven Bell

PE, ENV SP, CFM, QSD

Project Manager

RELEVANT EXPERIENCE

Moreno Valley WQMP Plan Check Senior Engineer assisting the City of Moreno Valley with on-call stormwater management services to ensure compliance with the Riverside County Municipal NPDES Stormwater Permit, CGP, and bacteria and nutrient TMDLs for the Santa Ana River Watershed. Responsibilities include reviewing a portion of over 250 Preliminary and Final WQMPs associated with new development and significant redevelopment projects, program management, regulatory support, public education, preparation of stormwater guidance materials, stormwater compliance inspections, municipal staff training, and review and recommendation of modifications to the City's standard plans, details, codes, and ordinances to ensure compliance.

City of El Monte Garvey Avenue Grade Separation Drainage Improvement Hydrology and Hydraulics Support for improving drainage infrastructure in the City of El Monte by identifying and delineating tributary areas that contribute stormwater flow to the Garvey Avenue underpass. The project involves upgrades to the existing drainage system, including installation of new catch basins, inlets, and storm drain pipes; improvements to the existing pump station diverting the stormwater to the storm drain system; and implementation of green infrastructure initiatives to retain, reuse, or infiltrate the collected stormwater runoff. Tasks performed include providing hydraulic modeling for an existing system on Durfee Avenue and preparing a preliminary report, modeling alternative designs for the Maxon Road storm drain, and drafting and designing details around the pump house. Additional tasks include project management; stakeholder outreach; technical evaluations; ROW acquisition; obtaining regulatory permits from the USACE, RWQCB, and CDFW; preparing PS&Es; developing an O&M plan; and providing assistance with funding opportunities.



Years of Experience

17(2006)

Years with CWE

6

Education

MS, Civil Engineering,
University of Oklahoma

BS, Civil Engineering,
University of Oklahoma

Registrations

Civil Engineer, CA, 81531

Civil Engineer, OK, 24571

Envision™ Sustainability
Professional Credential,
30283

Certified Floodplain Manager,
US-19-11240

Qualified SWPPP Developer,
C81531

References

Hoang Nguyen, Associate
Engineer

City of Moreno Valley,
hoangn@moval.org
(951) 413-3216

Arlene Chun
Stormwater Program
Manager

San Bernardino County Flood
Control District
909-387-8109

Arlene.Chun@dpw.sbcounty.gov

Attachment: Agreement with CWE (6330 : AUTHORIZATION TO AWARD AGREEMENTS FOR PROFESSIONAL CONSULTING SENIOR





City of Moreno Valley
Consultant Senior Engineer Services

Torrance 190th/Prairie Avenue Neighborhood Water Main Replacement CWE is currently providing civil engineering design services to replace miscellaneous water mains in the City of Torrance. The City is in the process of replacing existing cast iron water mains with ductile iron water mains in the North Torrance neighborhood bounded by the 405 Freeway and 176th Street, to the west by Prairie Avenue, to the south by 182nd Street and the east by Yukon Avenue. Work includes the installation of approximately 9,100 linear feet of new water mains, valves, fire hydrants, services lines, meters, and the abandonment of the existing mains. Other tasks include the preparation of base maps, alignment alternatives, preliminary plans, 90% PS&Es, and 100% PS&Es, as well as providing bid-ready construction documents and attending design phase meetings.

Bell Gardens John Anson Ford Park Infiltration Project Hydrology and Hydraulics Support for developing design PS&Es for this urban runoff capture project. John Anson Ford Park is located in the City of Bell Gardens and the project helps the City and the Lower Los Angeles River Upper Reach 2 Watershed Management Group meet its NPDES MS4 Discharge requirements. The project captures dry weather and storm runoff from a highly industrialized urban catchment area of 2,295 acres. The project provides compliance with existing water quality objectives for the entire Rio Hondo watershed portion of the LAR UR2 WMA. Tasks included a geotechnical field analysis, utility search, hydrologic and hydraulic analysis, topographic mapping, preparation of design PS&Es, and construction engineering support.

Orange County Public Works Environmental Sciences On-Call Water Management Plan (WMP)-WQIP Best Management Practices associated with Water Quality Management Plans (WQMPs) are adequately designed, constructed, and maintained in accordance with permit requirements. Tasks include WQMP Design Reviews, WQMP Installation Reviews, Reporting and Additional Assistance, and Design Analysis and Recommendations for Existing BMPs.



City of Moreno Valley
Consultant Senior Engineer Services



Katie Harrell

PE, ENV SP, QSD

Project Manager

RELEVANT EXPERIENCE

Moreno Valley WQMP Plan Check Assistant Engineer assisting the City of Moreno Valley with on-call stormwater management services to ensure compliance with the Riverside County Municipal NPDES Stormwater Permit, CGP, and bacteria and nutrient TMDLs for the Santa Ana River Watershed. Responsibilities include reviewing a portion of over 250 Preliminary and Final WQMPs associated with new development and significant redevelopment projects, program management, regulatory support, public education, preparation of stormwater guidance materials, stormwater compliance inspections, municipal staff training, and review and recommendation of modifications to the City's standard plans, details, codes, and ordinances to ensure compliance.

Baldwin Park Barnes Park Multi-Benefit Project Project Manager for a project that will capture, treat and infiltrate approximately 440 acres of stormwater from various land uses within the City (mainly single-family residential, multi-family residential, and commercial). A diversion structure on the existing 81-inch diameter LACFCD Storm Drain (BI 9705) would divert stormwater from Bess Avenue into a pre-treatment device before being gravity fed into an underground infiltration gallery facility (BMP). Once stormwater fills the chamber, an actuated valve will close and take the system offline to prevent surcharge. The goal of this project is to treat, capture and infiltrate approximately 10 acre-feet of wet- and dry-weather flows, which is just shy of the stormwater runoff volume of the 85th percentile design storm. Engineering services include final design of a stormwater infiltration facility and above ground grading, specifications, and cost estimates for construction, O&M, and post-construction monitoring.

Culver City Washington Boulevard Assistant Project Manager assisting with the design of a diversion system to capture



Years of Experience

11

Years with CWE

11

Education

MS, Civil Engineering,
California State University,
Long Beach

BS, Civil Engineering,
California State University,
Long Beach

Registrations

Civil Engineer, CA, 85752

Civil Engineer, UT,
11267633-2202

Envision™ Sustainability
Professional Credential, 2333

Awards and Recognition

Civil + Structural magazine,
"Rising Star," 2018

Orange County Engineering
Council, "Young Engineer
Award," 2015

Storm Water Solutions
magazine, "Rising Star," 2015

References

Lee Torres, City Engineer,
11333 Valley Boulevard, El
Monte, California 91731-3293
(626) 580-2055

Iwen Tseng, Associate Civil
Engineer, 900 S. Fremont
Avenue
Alhambra, California 91803
(626) 458-4310





City of Moreno Valley
Consultant Senior Engineer Services

stormwater and urban runoff from a drainage area of approximately 40 acres for the City of Culver City. The project is located on Washington Boulevard near Walnut Avenue at the City boundary. The drainage area is comprised of commercial and residential land uses within the City boundaries. The system captures approximately 122,000 cubic feet of stormwater runoff. Tasks included review of the Geotechnical Investigation Report and Percolation Test Results, developing project concepts for diversion and biofiltration systems, conducting an environmental study, performing hydrologic and hydraulic analyses and preparing a report, coordinating with the LACPW, performing a topographic survey, conducting a utility search for the project site to identify existing or planned future utility conflicts along the proposed project components, preparing PS&Es, providing community outreach support, and providing construction support services.

Manhattan Beach 28th Street Stormwater Infiltration Project Manager for design services at the 26th Street Parking Facility referred to as the 28th Street Storm Drain Infiltration project, as runoff will be captured from the storm drain on 28th Street between Ocean Drive and the beach. The project, one of several CWE-identified implementation alternatives the City of Manhattan Beach could follow to improve water quality in accordance with the Beach Cities Enhanced Watershed Management Program (EWMP), will be designed with the goal of capturing up to 63 acre-feet of runoff during a single storm event, and includes drywells, a pumped diversion system, pretreatment unit, distribution piping, and an improved parking facility. Additional amenities, such as nature-based solutions (trees/landscape) and site-scale solar environmental improvements are being evaluated as part of the design process. Tasks include project management and meeting coordination; hydrologic and hydraulic analyses using WMS and WSPG software; utility coordination; obtaining a Los Angeles County Flood Control District (LACFCD) connection permit and California Coastal Connection (CCC) permit; property-related coordination and approval from the Los Angeles County Beaches and Harbors (LACBH); California Environmental Quality Act (CEQA) compliance and preparing an Initial Study/Mitigated Negative Declaration (IS/MND) to meet these requirements; cultural assessment and noise and vibration analysis; development of PS&Es; topographic survey; potholing; Supervisory Control and Data Acquisition (SCADA) integration; geotechnical exploration; preparing a construction Stormwater Pollution Prevention Plan (SWPPP); preparing an O&M manual; bid and construction support; assisting in securing funding for the project through the Safe, Clean Water Program (SCWP) Regional Program and California Natural Resources Agency Proposition 68; and Envision™ certification.

City of Los Angeles Connecting San Pedro Project Manager for the design of the Task Order Solicitation (TOS) 10, Connecting San Pedro: Pedestrian Improvement and Multimodal Access Project, which includes a variety of street/sidewalk improvements to enhance safety and support multiple modes of transportation. Several curb ramps were designed as part of this Project to meet Americans with Disabilities (ADA) Act as well as goals and objectives outlined in Vision Zero and Sustainable City pLAN.



City of Moreno Valley
Consultant Senior Engineer Services



Larry Tortuya

PE, ENV SP, CFM, QSD/P

Project Manager

RELEVANT EXPERIENCE

Palos Verdes Peninsula Multi-Benefit Flow Diversion

Project Project Manager for a Safe Clean Water Program (SCWP) Feasibility Study under Los Angeles County's Technical Resource Program (TRP). The project included the study of augmenting the City of Rolling Hills Estate water supply with captured storm water and groundwater from emerging springs as well as a water balance analysis and an irrigation supply analysis to determine service acreage that would be supplied by the additional captured water. CWE developed alternatives, assessed cost estimates for the alternatives, and evaluated the alternatives for constructability, ease of maintenance, schedule, and aesthetics. The project Feasibility Study and grant application will be submitted for consideration during the 2024-2025 SCWP call for projects.

Buena Park ADA, Fire Line, and Drainage Study

Project Manager for the development of the fire line size, location, and path along with the tie-in connection to the City's Water Main in Beach Boulevard. The design utilized City standards for water line appurtenances such as a backflow preventer, hot tap connection, detector check assembly and gate valve. As part of the project CWE also performed a drainage study of the parking lot, and an ADA sidewalk entrance ramp. CWE worked with a private developer to process the design plans through the City of Buena Park's permitting process.

City of Torrance Beach Cities Green Streets

Assistant Project Manager for the development of green streets in the Beach Cities of Torrance, Redondo Beach, Hermosa Beach, and Manhattan Beach to capture runoff generated from the 85th percentile storm event so that it doesn't reach the surf zone as identified in the Beach Cities Enhanced Watershed Management Plan. This project is funded by an SCC Grant. The project will collect stormwater from over 200 acres that generate runoff, reduce the volume of runoff, and filter out trash from entering the Herondo and 28th Street storm drains from the four Beach Cities. Hydrographs for each project site were



Years of Experience

22

Years with CWE

3

Education

BS, Civil Engineering,
California State Polytechnic
University, Pomona, 2004

Registrations

Civil Engineer, CA, 71502

Envision™ Sustainability
Professional Credential,
22637

Certified Floodplain Manager

US-17-09965

Qualified SWPPP Developer/
Practitioner, 27594

References

Paul Pham, Associate
Engineer, 300 North Coast
Highway, Oceanside,
California 92054,
760-435-5030,

Edward Frondoso, Deputy
Director, O&M, 601 North
Ross Street, Santa Ana,
California 92701
714-352-1118



City of Moreno Valley
Consultant Senior Engineer Services

produced using LA County Hydrocalc, and a 20-year simulation model was performed using EPA SWMMM. A variety of BMPs, including porous pavement; catch basin trash screens; biofiltration/bioretenion systems; natural systems such as vegetated curb extensions, planters, swales, and rain gardens; and drywells are being designed to intercept, filter, and retain runoff between various locations. This project addresses water quality issues in the Santa Monica Bay including TMDLs for dry- and wet-weather bacteria, nearshore and offshore debris, and toxic chemicals such as DDT and PCB that often result in beach closures. Tasks managed include project management; preliminary and final design PS&Es; research, data collection, and analysis of utility and street plans, GIS data, Beach Cities Reasonable Assurance Analysis (RAA) and CIMP data, City-specific templates and plan sets, and stakeholder organizations; community outreach; geotechnical exploration; topographic survey; utility search and potholing; hydrologic analyses; permitting and preparing an IS/MND in accordance with CEQA; dry- and wet-weather monitoring and maintenance that includes an MRP and QAPP; and providing engineering support during bid and construction phases.

City of Anaheim Modjeska Park Regional Stormwater BMP System Task Manager for the production of the Preliminary Design Report which assessed over 20 different underground systems for stormwater capture and infiltration, and was responsible for the sizing and design of the underground stormwater BMP. PCSWMM was used to optimize the design of the system and appropriately size the underground volume capacity. The project is funded by Proposition 1 grant, and has state requirements for design, schedule, and budget.

Attachment: Agreement with CWE (6330 : AUTHORIZATION TO AWARD AGREEMENTS FOR PROFESSIONAL CONSULTING SENIOR





City of Moreno Valley
Consultant Senior Engineer Services



Bill Young

PE

Senior Project Manager (QA/QC)

RELEVANT EXPERIENCE

Rancho Palos Verdes Storm Drain Project Manager for design services on the City of Rancho Palos Verdes Storm Drain Point Repair project. The City completed a storm drain lining project in 2013, and during that project, a number of pipes were identified as requiring replacement or significant repairs before lining could be completed. Tasks included replacement or repair design for over 1,500 feet of storm drains in 11 different locations, drainage course bank revetment, reviewing existing records and data, conducting hydrologic and hydraulic analyses for each of the sites, performing topographic surveys, performing geotechnical investigations, locating utilities, conducting biological assessments, obtaining necessary permits, and preparing PS&Es for each of the 11 project sites.

City of Hermosa Beach Repair Analysis Project Manager for civil engineering services on the design of repairs to the 122,000 square feet, three-level, North Pier Parking Structure. This task order included PS&Es for the repair of the structure concrete sections and railing, replacement of the sump pump system, and electrical system repairs including lighting and elevator. Also performed a condition assessment of these facilities that was presented in a report format with recommendations for repairs, maintenance, or additional nondestructive testing/monitoring if necessary. Structure assessment services were performed to document the existing condition of the structure in representative areas, determine if monitoring or invasive testing was warranted in determining the cause of cracks, and recommend conceptual repairs/provided an opinion of probable cost for the conceptual repairs.

City of Hermosa Beach Sidewalk Resurfacing Project Manager for the design of the curb grades, ADA ramps, and transitional areas. The design of the improvements was on the City sheet borders with plan view only and grades noted with rates and spot elevations prepared.

Burton Chase Park Design Lead for an irrigation plan of Burton Chase Park in Marina Del Rey to be incorporated into the Final Construction Plans along with specifications for the components in the irrigation system. Deliverables included Demolition Plan, Stormwater Pollution Prevention Plan, Refined Grading Plan, ADA Circulation Plan, Landscape Irrigation Plans, Specifications, and Cost estimates with the construction plans in PDF and AutoCAD 2018 DWG formats.

Garvey Avenue Grade Separation Design Lead for improving drainage infrastructure and landscaping for a 140-acre, two-mile rehabilitation project that will provide major upgrades to several streets, including construction of landscape median islands, ADA-compliant curb ramp enhancements,



Years of Experience

40

Years with CWE

8

Education

BS, Civil Engineering, 1979,
California State Polytechnic
University, Pomona

Registrations

Civil Engineer, CA, 35715

Awards and Recognition

American Society of Civil
Engineers



City of Moreno Valley
Consultant Senior Engineer Services

repairs to damaged sidewalks, driveways, and curb and gutter, and the installation of new Class II bike lanes. The project involved identifying and delineating tributary areas that contribute stormwater flow to the Garvey Avenue underpass; developing landscaping and irrigation enhancement plans that are consistent with the City’s Ramona Boulevard median landscape improvements; providing upgrades to the existing drainage system, including installation of new catch basins, inlets, and storm drain pipes; improvements to the existing pump station diverting the stormwater to the storm drain system; and implementation of green infrastructure initiatives to retain, reuse, or infiltrate the collected stormwater runoff. Drainage improvement tasks included project management; stakeholder outreach; technical evaluations; ROW acquisition; obtaining regulatory permits from the USACE, RWQCB, and California Department of Fish and Wildlife (CDFW); preparing PS&Es; developing an Operations and Maintenance (O&M) plan; and providing assistance with funding opportunities. Landscape improvement plans include utility research and investigation, field survey, potholing, preliminary and final design street improvement plans, striping and signage plans, streetlighting plans, monument signage, bike master plan, and wayfinding signs.

City of Burbank Johnny Carson Park Improvement and Stream Restoration Project Manager for civil design services for park improvements and the restoration of an urban stream through the 17-acre Johnny Carson Park in the City of Burbank. The restoration involved the removal of concrete and asphalt stream channel lining and its replacement with a bioengineered channel. The channel flows under two pedestrian bridges that required evaluation for loads as well as analysis for scour related to flow constrictions since the abutments were to remain in place. A topographic survey was conducted, the bridges were inspected, the channel hydraulics were analyzed, and a restored channel was designed. Other services included PS&Es for grading, drainage, access road enhancements, retaining walls, and walking trails.

Attachment: Agreement with CWE (6330 : AUTHORIZATION TO AWARD AGREEMENTS FOR PROFESSIONAL CONSULTING SENIOR





City of Moreno Valley
Consultant Senior Engineer Services



Vik Bapna

PE, ENV SP, CPSWQ, QSD/P

Principal (Principal-in-Charge)

RELEVANT EXPERIENCE

City of Los Angeles Laurel Canyon Boulevard Green Street

Project Manager for the design of bioswales with drywells along 1,000 linear feet of Laurel Canyon Boulevard for LA Sanitation – City of Los Angeles and the Los Angeles Conservation Corps. The project provided increased groundwater recharge, reduced flooding impacts, protected compatible beneficial uses, and improved the neighborhood quality of life. This was accomplished by the design of a series of infiltration swales and drywells along Laurel Canyon Boulevard between Kagel Canyon Street and Terra Bella Street with curb, gutter, and sidewalk improvements. The project collected stormwater runoff from an approximately 125-acre drainage area. Duties included developing civil design, landscaping, and traffic control plans, construction inspection and management, and conducting dry- and wet-weather monitoring. This project received awards from the ASCE Los Angeles Section, ASCE Metropolitan Los Angeles Branch, and CASQA.

City of Hermosa Beach Water Quality Monitoring During the Repair of the Hermosa Beach Pier

Principal-in-Charge for professional water quality monitoring services in conjunction with the City of Hermosa Beach for the Hermosa Beach Pier Repair Project. The project involved the repair of six spalled concrete piles, replacement of a 32-foot by 5-foot section of pier deck, and other minor bracket and conduit repairs. While the deck work was over beach sand with little risk of marine contamination, most of the damaged piles sections were over or, in one case, in the ocean. Since there was a potential risk of marine contamination during construction, especially during repair of the piles, water quality monitoring to document pre-, during-, and post-project conditions was performed. Tasks included drafting and submitting a water quality monitoring plan, implementing the approved monitoring plan, and preparing monthly and final monitoring reports.



Years of Experience

32

Years with CWE

17

Education

BS, Civil Engineering,
New Jersey Institute of
Technology

Registrations

Civil Engineer, CA, Number

Envision™ Sustainability
Professional Credential,
18196

Certified Professional in
Storm Water Quality, 543

Qualified SWPPP Developer/
Practitioner, 368

Awards and Recognition

Orange County Engineering
Council, "Outstanding
Engineering Merit Award,"
2015

Storm Water Solutions
magazine, "Industry Icon,"
2015

References

Wendy Bui
Senior Engineer
900 S. Fremont Avenue,
Alhambra, California 91803
(626) 300-4593

Kenneth Jones
Management Analyst
117 Macneil Street, San
Fernando, California 91340
(818) 898-1240





City of Moreno Valley
Consultant Senior Engineer Services

City of Torrance Machado Lake Trash Screen Catch Basin Construction Administration

Project Manager for the installation of full-capture trash screens on catch basins to assist the Cities of Torrance, Carson, Lomita, Los Angeles, Palos Verdes Estates, Rancho Palos Verdes, Redondo Beach, Rolling Hills, and Rolling Hills Estates, as well as Caltrans, Los Angeles County, and the LACFCD with continued Machado Lake Trash TMDL compliance. Tasks managed included monitoring the installation of catch basin trash screens; verifying construction compliance with PS&Es; monitoring traffic control; preparing daily inspection reports; reviewing construction submittals for compliance with PS&Es; processing payment requests; assisting with change order negotiations; reviewing proposed work plans and discussing discrepancies with contractor; developing "Punch List" items; serving as a liaison between the contractor and City; and preparing a set of as-built plans.

City of Claremont Foothill Boulevard Master Plan Implementation Project Manager for hydrology and hydraulic analyses services, design of storm drains, bioswales, and water quality systems and structures to meet LID Plan requirements. The project included the design and engineering of the improvements contained in the Foothill Boulevard Master Plan, which encompassed minor roadway and intersection improvements, pedestrian improvements at intersections that include bulb-outs and median refuge islands at five intersections, restriping, infill sidewalks, minor lighting improvements, bicycle lanes and protected bicycle lanes, removal of turf and installing drought-tolerant landscaping in medians and some parkway areas, bioswales, stormwater percolation devices, and a 1,000-foot-long section of new storm drain. The Master Plan spreads the improvements out over three phases and the project plans are to include all three phases. Tasks included a hydrology/hydraulic study, preparing SWPPP and stormwater permit/planning documents, developing project plans for bioswales and storm drains, developing a construction and maintenance budget and project specifications for drainage features, preparing PS&Es, responding to RFIs related to design, conducting field visits, preparing as-built drawings, and making plan revisions. This project was the recipient of the 2020 American Public Works Association (APWA) Best Award for Stormwater Quality.



City of Moreno Valley
Consultant Senior Engineer Services



Farooq Qureshi

MBA, ENV SP

Senior Project Manager (Resource Manager)

RELEVANT EXPERIENCE

LACPW Environmental Compliance Manager (ECM)

Support Services Project Manager for ECM Services to support Los Angeles County's Construction Program. Tasks managed include the monitoring of environmentally related construction operations like dewatering and the excavation, handling, and disposal of contaminated soil and water. Also managed materials detection, analysis, and handling as well as noise and air concerns.

City of LA Bureau of Engineering (BOE) Task Order Solicitation (TOS) 10 – Connecting San Pedro Multi-Modal Project

Client Manager for the TOS 10 - Connecting San Pedro: Pedestrian Improvement and Multimodal Access Project, which includes a variety of street/sidewalk improvements to enhance safety and support multiple modes of transportation. CWE submitted the Preliminary Design Report (PDR), 35% plans, 50% plans, and 90% plans for the Project. Additional tasks include the redesign of several corners by relocating the bus stops at this intersection as well as a new signal, two additional curb ramps, design of curb ramps, updated striping, and updated signal plans.

City of Santa Barbara Stormwater On-Call Program Manager for the design and construction of the City of Santa Barbara Bohnett Park stormwater treatment system. The project system captures, treats, and infiltrates storm water from two 18-inch storm drains. Tasks included project management and coordination, schedule and budget tracking, and coordination with the City Project Manager, data review of storm drain records and LiDAR maps, utilities within the park, design plans for park improvements, existing geotechnical information, and the City's Storm Water Best Management Practice Guidance Manual.

City of Fontana Design Support Program Manager responsible for creating a WQMP handbook to help streamline the WQMP process and educate City staff and developers. The handbook is an easy-to-use document that summarizes the guidelines associated with the San Bernardino County WQMP template and provides information specific to the City. The document covers basic WQMP requirements, such as the thresholds that identify whom must develop a WQMP and how the WQMP is to be developed; identify the City's pre-approved treatment methods based on the City's maintenance preferences and what the City believes the contractors are capable of adequately maintaining.



Years of Experience

24

Years with CWE

5

Education

MBA, Technology,
University of California, Irvine

BS, Biochemistry and
Computing, University of
California, Los Angeles

Registrations

Envision™ Sustainability
Professional Credential,
28214

Certified Network
Administrator (CAN), 1998





City of Moreno Valley
Consultant Senior Engineer Services



Mike Nguyen

Senior Engineer (Technical Resource)

RELEVANT EXPERIENCE

City of Manhattan Beach Santa Monica Bay Total Maximum Daily Load High Flow Capacity Trash Treatment Control Devices

Design and CAD Support for FCS devices in 12 locations that trap particles retained by a 5mm mesh screen and have a design treatment capacity of not less than the peak flow rate resulting from a 1-year, 1-hour storm in the subdrainage area. Under the Los Angeles RWQCB's Trash TMDL for Santa Monica Bay Nearshore and Offshore Marine Debris, cities, Los Angeles County, and Caltrans must take actions to reduce, and eventually eliminate discharges of anthropogenic trash from leaving their jurisdictions and entering downstream waterways and beaches. Providing design services that cover the evaluation and design of High Flow Capacity Trash Treatment Control Devices, sometimes also referred to as CDS or hydrodynamic separators, to meet waste load allocations for trash discharge under the Santa Monica Bay Marine Debris TMDL requirements. Additional tasks include project management, meetings, and quality control; public outreach and engagement; utility and agency coordination; background research, surveying, and field verification; potholing; geotechnical investigations; applying for and obtaining construction permits; developing O&M cost estimates; CEQA compliance; bid phase assistance; engineering services during construction; and preparation of record drawings.

East Los Angeles Dialysis Center Civil Design Senior Engineer providing civil engineering services for a proposed dialysis center in Los Angeles. Tasks included preparing a topographic survey; a site utility search to obtain information on domestic water, sanitary sewer, and electrical line availability; preparing a grading and drainage plan for the development and construction of the building pad and parking lot and to meet City of Los Angeles requirements; providing a site-specific LID Plan to incorporate post-construction BMPs and LID strategies to mitigate stormwater runoff; and preparing an erosion control plan that provides site-specific BMPs to control erosion and the discharge of sediments, manage non-stormwater discharges, and contain materials and wastes.

Mountains Recreation and Conservation Authority Mission Canyon Trailhead Design Support for the preparation of civil, structural, and electrical plans and specifications for the Mission Canyon Trailhead project. Civil engineering services include preparing a site grading plan using topographic survey and site layout, preparing site control and utility plans (electrical, sewer, and potable water), preparing drainage design and calculations, preparing water quality-required designs and reports, preparing Construction Specifications Institute (CSI) format civil specifications, providing permitting support, and coordinating with CEQA to provide estimate quantities of earthwork and pavement. Structural engineering services include reviewing geotechnical reports, preparing structural notes and calculations, and reviewing plans, elevations, sections, and details for the retaining wall and parking lot light foundation. Electrical engineering services include preparing electrical plans for modular restroom



Years of Experience

17

Years with CWE

8

Education

BS, Civil Engineering, 2005
California State Polytechnic
University, Pomona



City of Moreno Valley
Consultant Senior Engineer Services

and parking lot lighting, calculating electrical loads and Title 24 requirements, preparing CSI specifications, and preparing electrical site layout plans including wiring and grounding systems layouts, details, and properly wiring sizing for current carrying and ground wiring.

Placentia and Harvill LLC, Truck Maintenance and Fuel Facility Design Support for planning, environmental, and engineering services for the design of the Placentia and Harvill, LLC Truck Maintenance and Fuel Facility located on the Southeast corner of Harvill and Placentia Avenues in Mead Valley. The project included a 14,000 square foot maintenance facility, a 5,000+ square foot fuel island area, design of 543 feet of private storm drains and onsite utility connections, accommodations for 433 vehicles/trucks/trailers, and the design of two bioretention basins with a total volume of over 3.2 acre-feet. Additional environmental permits were acquired in line with State and Federal regulations, due to truck maintenance and fueling activities. Tasks included a drainage plan and preliminary drainage study, preliminary Water Quality Management Plan (WQMP), a site plan, preparing a parcel merger, preliminary plan processing, environmental documentation, preparing a biological assessment, a cultural resources assessment, air quality and greenhouse gas impact study, preparing an Initial Study (IS) and Mitigated Negative Declaration (MND), and providing a Mitigation Monitoring and Reporting Program (MMRP) and preparation of a site specific Stormwater Pollution Prevention Plan (SWPPP).

Attachment: Agreement with CWE (6330 : AUTHORIZATION TO AWARD AGREEMENTS FOR PROFESSIONAL CONSULTING SENIOR





City of Moreno Valley
Consultant Senior Engineer Services



Lien Tran

EIT

Senior Engineer (Technical Resource)

RELEVANT EXPERIENCE

City of Culver City Washington Boulevard P3 Urban

Runoff Diversion Senior Engineer for assisting with the design of a diversion system to capture stormwater and urban runoff from a drainage area of approximately 40 acres for the City of Culver City. The project is located on Washington Boulevard near Walnut Avenue at the City boundary. The drainage area is comprised of commercial and residential land uses completely within the City boundaries. The system captures approximately 122,000 cubic feet of stormwater runoff. Tasks included reviewing the Geotechnical Investigation Report and Percolation Test Results, developing project concepts for diversion and bio-filtration systems, conducting an environmental study, performing hydrologic and hydraulic analyses and preparing a report, coordinating with the LACPW, performing a topographic survey, conducting a utility search for the project site to identify existing or planned future utility conflicts along the proposed project components, preparing PS&Es, providing community outreach support, and providing construction support services.

Los Angeles County Public Works Bassett Channel Flood Control Facility Improvements

Senior Engineer for an invert access ramp near Basetdale Avenue. Tasks include developing a hydraulic 1-D model in HEC-RAS for the existing channel system using existing hydrologic flow rates provided by LACPW; identifying the best location for ramps based on the existing conditions hydraulic model so that potential impacts will be minimal to the water surface elevation of the channel; conducting a utility search located within the public right-of-way; providing a project concept report; providing a geotechnical evaluation, including six borings up to five feet in depth for the access road and one 30-foot boring and one 50-foot boring for the invert access ramp; topographic survey georeferenced using NAD83 for horizontal control and NAVD88 for vertical control; delivering 60%, 90%, and 100% PS&E packages; and regulatory permitting assistance.

20388 City of Torrance Beach Cities Green Streets Senior Engineer for the development of green streets in the Beach Cities of Torrance, Redondo Beach, Hermosa Beach, and Manhattan Beach to capture runoff generated from the 85th percentile storm event so that it doesn't reach the surf zone, as identified in the Beach Cities Enhanced Watershed Management Plan. The project will collect stormwater from over 200 acres that generate runoff, reduce the volume of runoff, and filter out trash from entering the Herondo and 28th Street storm drains from the four Beach Cities. A variety of BMPs, including porous



Years of Experience

20

Years with CWE

1

Education

BS, Civil Engineering, 2018,
California State University,
Fullerton

Registration

Engineer-in-Training, CA,
146082





City of Moreno Valley
Consultant Senior Engineer Services

pavement; catch basin trash screens; biofiltration/bioretenion systems; natural systems such as vegetated curb extensions, planters, swales, and rain gardens; and drywells are being designed to intercept, filter, and retain runoff between various locations. This project addresses water quality issues in the Santa Monica Bay, including TMDLs for dry- and wet-weather bacteria, nearshore and offshore debris, and toxic chemicals such as DDT and PCB that often result in beach closures. Tasks include project management; preliminary and final design PS&Es; research, data collection, and analysis of utility and street plans, GIS data, Beach Cities RAA and CIMP data, City-specific templates and plan sets, and stakeholder organizations; community outreach; geotechnical exploration; topographic survey; utility search and potholing; hydrologic analyses; permitting and preparing an IS/MND in accordance with CEQA; dry- and wet-weather monitoring and maintenance that includes an MRP and QAPP; and providing engineering support during bid and construction phases.

21431 City of El Monte Garvey Avenue Street and Landscape Improvements Senior Engineer assisting in pump comparison and selection that providing improvements to the existing stormwater pump station and related structures after the pump system failed. Tasks include replacing pumps and motors, replacing the control panel and electrical system, replacing corroded corrugated metal pipe (CMP) storm drains with equivalently-sized reinforced concrete pipe (RCP) or high-density polyethylene (HDPE) pipes, removing and replacing the curb and gutter on Garvey Avenue, conducting an outreach meeting to prepare the community for the necessity of the street closure, and obtaining Metrolink permitting. These improvements are part of a 140-acre, two-mile rehabilitation project that provides major upgrades to several streets, including construction of landscape median islands, ADA-compliant curb ramp enhancements, repairs to damaged sidewalks, driveways, and curb & gutter, and the installation of new Class II bike lanes. Additional tasks include providing utility research and investigation, field survey, potholing, preliminary and final design street improvement plans, striping and signage plans, streetlighting plans, landscaping and irrigation enhancement plans that are consistent with the Ramona Boulevard median landscape improvements, monument signage, bike master plan, and wayfinding signs.

Attachment: Agreement with CWE (6330 : AUTHORIZATION TO AWARD AGREEMENTS FOR PROFESSIONAL CONSULTING SENIOR





City of Moreno Valley
Consultant Senior Engineer Services



Angelique Silvestre

EIT, ENV SP

Staff Engineer (Technical Resource)

RELEVANT EXPERIENCE

City of El Monte Garvey Avenue Grade Separation

Drainage Improvement Grant Support for improving drainage infrastructure in the City of El Monte by identifying and delineating tributary areas that contribute stormwater flow to the Garvey Avenue underpass. The project involved upgrades to the existing drainage system, including installation of new catch basins, inlets, and storm drain pipes; improvements to the existing pump station diverting the stormwater to the storm drain system; and implementation of green infrastructure initiatives to retain, reuse, or infiltrate the collected stormwater runoff. Tasks included working on the project cost table, local cost share reduction attachment, and addressed City comments for Proposition 68 FMPRA.

City of Torrance Beach Cities Green Streets Staff Engineer assisting in the design for the development of green streets in the Beach Cities of Torrance, Redondo Beach, Hermosa Beach, and Manhattan Beach to capture runoff generated from the 85th percentile storm event. The project will collect stormwater from over 200 acres that generate runoff, reduce the volume of runoff, and filter out trash from entering the Herondo and 28th Street storm drains from the four Beach Cities. A variety of BMPs, including porous pavement; catch basin trash screens; biofiltration/bioretenion systems; natural systems such as vegetated curb extensions, planters, swales, and rain gardens; and drywells are being designed to intercept, filter, and retain runoff between various locations. Tasks include preliminary and final design PS&Es; research, data collection, and analysis of utility and street plans, GIS data, Beach Cities RAA and CIMP data, City-specific templates and plan sets, and stakeholder organizations; community outreach; geotechnical exploration; topographic survey; utility search and potholing; hydrologic analyses; permitting and preparing an IS/MND in accordance with CEQA; dry- and wet-weather monitoring and maintenance that includes an MRP and QAPP; and providing engineering support during bid and construction phases.

City of Los Angeles BOE TOS No. 10 – Design and Engineering Support Services for the Connecting San Pedro: Pedestrian Improvement and Multimodal Access Project

Angelique is Assistant Engineer aiding in the development of street improvement pre-design and pre-design reports which document existing conditions, the design approach, and 35% plan development. This Project is part of the Measure M Multi-Year Sub Regional Plan (Measure M MSP) – Transportation System and Mobility Improvements Program (TSMIP) adopted in May 2018, for which the primary goals include improved traffic flow/safety, repaired sidewalks, repaved streets, and improved connectivity.



Years of Experience

6

Years with CWE

3

Education

BS, Civil Engineering,
University of Portland

Registrations

Envision™ Sustainability
Professional, 46089



4. Required Statements

As instructed in the RFP, the following statements are incorporated into our proposal:

4.1: CWE acknowledges that the RFP shall be incorporated in its entirety as a part of CWE's Proposal.

4.2: CWE acknowledges that this RFP and CWE's Proposal will jointly become part of the Agreement for Professional Consultant Services for this project when said Agreement is fully executed by CWE and the City Manager of Moreno Valley.

4.3: CWE acknowledges that our services to be provided, and fees therefore, will be in accordance with the City's RFP except as otherwise specified in CWE's Proposal under the heading "ADDITIONS OR EXCEPTIONS TO THE CITY'S REQUEST FOR PROPOSAL."

4.4: CWE shall provide a single and separate section with the heading "ADDITIONS OR EXCEPTIONS TO THE CITY'S REQUEST FOR PROPOSAL" containing a complete and detailed description of all the exceptions to the provisions and conditions of this Request for Proposal upon which CWE's Proposal is contingent and which shall take precedence over this RFP.

4.5: CWE shall provide a statement of qualifications applicable to this project including the names, qualifications, and proposed duties of the Consultant's Staff to be assigned to this project; a listing of recent similar projects completed, including the names, titles, addresses, and telephone numbers of the appropriate persons whom the City could contact. If one or more of the Consultant's staff should become unavailable, CWE may substitute other staff of at least equal competence only after prior written approval by the City.

4.6: CWE shall submit a resource allocation matrix with the Proposal listing detailed tasks in rows and the appropriate individual (Job Title Only) as well as the number of hours/availability that these individuals will be working on each task listed. The resource allocation matrix and the project design schedule are required of both the primary consultant (CWE) as well as any subconsultant. In addition, the applicable construction support services must list the type and number of hours of geotechnical tests being proposed, as well as the type and number of hours of inspection or survey work within the Proposal. Failure to do so will result in CWE's Proposal being deemed incomplete and it will not receive further consideration. The construction support services Consultant is not required to provide a Project Schedule with milestones.

4.7: CWE is not proposing the use of, or intends to engage the use of, subconsultants on this project.

4.8: CWE acknowledges and understands that CWE will not be allowed to change subconsultants without written permission from the City.

4.9: CWE acknowledges that all charges for Consultant (construction) services are a "Not-to-Exceed Fee" which must include conservatively estimated reimbursable expenses, as submitted with and made a part of a Consultant's Proposal.

4.10: CWE will document and provide the results of the work to the satisfaction of the City. This may include the preparation of field and final reports or similar evidence of attainment of the Agreement objectives.

4.11: CWE will immediately document and notify the City of any defects or hazardous conditions observed in the vicinity of the project site prior, during, or after the construction work.



City of Moreno Valley
Consultant Senior Engineer Services

4.12: CWE shall provide a copy of our hourly rate schedule and a statement that said hourly rate schedule is part of the Consultant's Proposal for use in invoicing for progress payments and for extra work incurred that is not part of this RFP. An itemized cost breakdown for the work described herein must be submitted in a separate file, entitled Cost file, as part of the Consultant's Proposal submittal. All extra work will require prior approval from the City.

4.13: CWE will not discriminate against any employee or applicant for employment because of race, color, religion, sex, or national origin.

4.14: CWE shall adhere to all federal laws and regulations notwithstanding any state or local laws and regulations. In a case of conflict between federal, state, or local laws or regulations, the strictest shall be adhered to.

4.15: CWE shall allow all authorized federal, state, county, and City officials access to the place of work, books, documents, papers, fiscal, payroll, materials, and other relevant contract records pertinent to this special project. All relevant records shall be retained for at least three years.

4.16: CWE shall comply with the Davis-Bacon Fair Labor Standards Act (40 USC 276-a through a-7), and the implementation regulations issued pursuant thereto (29 CFR Section 1, 5), any amendments thereof, and the California Labor Code. Pursuant to the said regulations, entitled "Federal Labor Standards Provisions," Federal Prevailing Wage Decision" and State of California prevailing wage rates, respectively.

4.17: CWE shall comply with the Copeland Anti-Kickback Act (18 USC 874) and the Implementation Regulation (29 CFR 3) issued pursuant thereto, and any amendments thereof.

4.18: CWE offers and agrees to assign to the City all rights, title, and interest in and to all causes of action it may have under Section 4 of the Clayton Act (15 USC Sec. 15) or under the Cartwright Act (Chapter 2 [commencing with Section 16700] of Part 2 of Division 7 of the Business and Professions Code), arising from purchases of goods, services, or materials pursuant to the public works or the subcontract. This assignment shall be made and become effective at the time the City tenders final payment to CWE, without further acknowledgment by the parties.

5. Required Forms

The following RFP designated required forms are included at the end of this proposal:

- Non-Collusion Declaration Form
- Exhibit 10-Q1, Consultant Proposal DBE Commitment
- Exhibit 10-Q. Disclosure of Lobbying Activities

6. Cost Proposal

As instructed in the RFP, a cost proposal (Fee Schedule) has been submitted separately from this technical proposal.

7. Additions or Exceptions to the City's RFP

CWE has no additions or exceptions to the City's RFP.

NONCOLLUSION DECLARATION

(To be executed by Bidder and Submitted with Bid)

The undersigned declares:

I am the PRINCIPAL of CWE, the party making the foregoing bid.

The bid is not made in the interest of, or on behalf of, any undisclosed person, partnership, company, association, organization, or corporation. The bid is genuine and not collusive or sham. The bidder has not directly or indirectly induced or solicited any other bidder to put in a false or sham bid. The bidder has not directly or indirectly colluded, conspired, connived, or agreed with any bidder or anyone else to put in a sham bid, or to refrain from bidding. The bidder has not in any manner, directly or indirectly, sought by agreement, communication, or conference with anyone to fix the bid price of the bidder or any other bidder, or to fix any overhead, profit, or cost element of the bid price, or of that of any other bidder. All statements contained in the bid are true. The bidder has not, directly or indirectly, submitted his or her bid price or any breakdown thereof, or the contents thereof, or divulged information or data relative thereto, to any corporation, partnership, company, association, organization, bid depository, or to any member or agent thereof, to effectuate a collusive or sham bid, and has not paid, and will not pay, any person or entity for such purpose.

Any person executing this declaration on behalf of a bidder that is a corporation, partnership, joint venture, limited liability company, limited liability partnership, or any other entity, hereby represents that he or she has full power to execute, and does execute, this declaration on behalf of the bidder.

I declare under penalty of perjury under the laws of the State of California that the foregoing is true and correct and that this declaration is executed on 9/18/23[date], at FULLERTON [city], CA [state].

By: 
(signature)

Printed Name: VIK BAPNA

Title: PRINCIPAL

Attachment: Agreement with CWE (6330 : AUTHORIZATION TO AWARD AGREEMENTS FOR PROFESSIONAL CONSULTING SENIOR

EXHIBIT 10-01 CONSULTANT PROPOSAL DBE COMMITMENT

1. Local Agency: City of Moreno Valley 2. Contract DBE Goal: To be Determined (TBD)
 3. Project Description: Professional Consultant Senior Engineer Services
 4. Project Location: Within City of Moreno Valley Limits
 5. Consultant's Name: CWE 6. Prime Certified DBE:

7. Description of Work, Service, or Materials Supplied	8. DBE Certification Number	9. DBE Contact Information	10. DBE %
Perform project management and implementation			TBD
Local Agency to Complete this Section			11. TOTAL CLAIMED DBE PARTICIPATION TBD IMPORTANT: Identify all DBE firms being claimed for credit, regardless of tier. Written confirmation of each listed DBE is required.
17. Local Agency Contract Number: _____ 18. Federal-Aid Project Number: _____ 19. Proposed Contract Execution Date: _____ 20. Consultant's Ranking after Evaluation: _____ Local Agency certifies that all DBE certifications are valid and information on this form is complete and accurate.			
_____ 21. Local Agency Representative's Signature	_____ 22. Date	 12. Preparer's Signature	09/18/2023 13. Date
_____ 23. Local Agency Representative's Name	_____ 24. Phone	VIK BAPNA 14. Preparer's Name	714-526-7500 15. Phone
_____ 25. Local Agency Representative's Title	PRINCIPAL 16. Preparer's Title		

The Consultant is to fill out Exhibit 10-02 prior to working on a federal or state funded project with specific DBE goal to meet.

DISTRIBUTION: Original – Included with consultant's proposal to local agency.

ADA Notice: For individuals with sensory disabilities, this document is available in alternate formats. For information call (916) 654-6410 or TDD (916) 654-3880 or write Records and Forms Management, 1120 N Street, MS-89, Sacramento, CA 95814.

Attachment: Agreement with CWE (6330 : AUTHORIZATION TO AWARD AGREEMENTS FOR PROFESSIONAL CONSULTING SENIOR

INSTRUCTIONS – CONSULTANT PROPOSAL DBE COMMITMENTCONSULTANT SECTION

- 1. Local Agency** - Enter the name of the local or regional agency that is funding the contract.
- 2. Contract DBE Goal** - Enter the contract DBE goal percentage as it appears on the project advertisement.
- 3. Project Location** - Enter the project location as it appears on the project advertisement.
- 4. Project Description** - Enter the project description as it appears on the project advertisement (Bridge Rehab, Seismic Rehab, Overlay, Widening, etc.).
- 5. Consultant's Name** - Enter the consultant's firm name.
- 6. Prime Certified DBE** - Check box if prime contractor is a certified DBE.
- 7. Description of Work, Services, or Materials Supplied** - Enter description of work, services, or materials to be provided. Indicate all work to be performed by DBEs including work performed by the prime consultant's own forces, if the prime is a DBE. If 100% of the item is not to be performed or furnished by the DBE, describe the exact portion to be performed or furnished by the DBE. See LAPM Chapter 9 to determine how to count the participation of DBE firms.
- 8. DBE Certification Number** - Enter the DBE's Certification Identification Number. All DBEs must be certified on the date bids are opened.
- 9. DBE Contact Information** - Enter the name, address, and phone number of all DBE subcontracted consultants. Also, enter the prime consultant's name and phone number, if the prime is a DBE.
- 10. DBE %** - Percent participation of work to be performed or service provided by a DBE. Include the prime consultant if the prime is a DBE. See LAPM Chapter 9 for how to count full/partial participation.
- 11. Total Claimed DBE Participation %** - Enter the total DBE participation claimed. If the total % claimed is less than item "Contract DBE Goal," an adequately documented Good Faith Effort (GFE) is required (see Exhibit 15-H DBE Information - Good Faith Efforts of the LAPM).
- 12. Preparer's Signature** - The person completing the DBE commitment form on behalf of the consultant's firm must sign their name.
- 13. Date** - Enter the date the DBE commitment form is signed by the consultant's preparer.
- 14. Preparer's Name** - Enter the name of the person preparing and signing the consultant's DBE commitment form.
- 15. Phone** - Enter the area code and phone number of the person signing the consultant's DBE commitment form.
- 16. Preparer's Title** - Enter the position/title of the person signing the consultant's DBE commitment form.

LOCAL AGENCY SECTION

- 17. Local Agency Contract Number** - Enter the Local Agency contract number or identifier.
- 18. Federal-Aid Project Number** - Enter the Federal-Aid Project Number.
- 19. Proposed Contract Execution Date** - Enter the proposed contract execution date.
- 20. Consultant's Ranking after Evaluation** - Enter consultant's ranking after all submittals/consultants are evaluated. Use this as a quick comparison for evaluating most qualified consultant.
- 21. Local Agency Representative's Signature** - The person completing this section of the form for the Local Agency must sign their name to certify that the information in this and the Consultant Section of this form is complete and accurate.
- 22. Date** - Enter the date the DBE commitment form is signed by the Local Agency Representative.
- 23. Local Agency Representative's Name** - Enter the name of the Local Agency Representative certifying the consultant's DBE commitment form.
- 24. Phone** - Enter the area code and phone number of the person signing the consultant's DBE commitment form.
- 25. Local Agency Representative Title** - Enter the position/title of the Local Agency Representative certifying the consultant's DBE commitment form.

INSTRUCTIONS FOR COMPLETING EXHIBIT 10-Q DISCLOSURE OF LOBBYING ACTIVITIES

This disclosure form shall be completed by the reporting entity, whether subawardee or prime federal recipient at the initiation or receipt of covered federal action or a material change to previous filing pursuant to title 31 U.S.C. Section 1352. The filing of a form is required for such payment or agreement to make payment to lobbying entity for influencing or attempting to influence an officer or employee of any agency, a Member of Congress an officer or employee of Congress or an employee of a Member of Congress in connection with a covered federal action. Attach a continuation sheet for additional information if the space on the form is inadequate. Complete all items that apply for both the initial filing and material change report. Refer to the implementing guidance published by the Office of Management and Budget for additional information.

1. Identify the type of covered federal action for which lobbying activity is or has been secured to influence, the outcome of a covered federal action.
2. Identify the status of the covered federal action.
3. Identify the appropriate classification of this report. If this is a follow-up report caused by a material change to the information previously reported, enter the year and quarter in which the change occurred. Enter the date of the last, previously submitted report by this reporting entity for this covered federal action.
4. Enter the full name, address, city, state, and zip code of the reporting entity. Include Congressional District if known. Check the appropriate classification of the reporting entity that designates if it is or expects to be a prime or subaward recipient. Identify the tier of the subawardee, e.g., the first subawardee of the prime is the first tier. Subawards include but are not limited to: subcontracts, subgrants, and contract awards under grants.
5. If the organization filing the report in Item 4 checks "Subawardee" then enter the full name, address, city, state, and zip code of the prime federal recipient. Include Congressional District, if known.
6. Enter the name of the federal agency making the award or loan commitment. Include at least one organization level below agency name, if known. For example, Department of Transportation, United States Coast Guard.
7. Enter the federal program name or description for the covered federal action (item 1). If known, enter the full Catalog of Federal Domestic Assistance (CFDA) number for grants, cooperative agreements, loans and loan commitments.
8. Enter the most appropriate federal identifying number available for the federal action identification in item 1 (e.g., Request for Proposal (RFP) number, Invitation for Bid (IFB) number, grant announcement number, the contract grant, or loan award number, the application/proposal control number assigned by the federal agency). Include prefixes, e.g., "RFP-DE-90-001."
9. For a covered federal action where there has been an award or loan commitment by the Federal agency, enter the federal amount of the award/loan commitments for the prime entity identified in item 4 or 5.
10. Enter the full name, address, city, state, and zip code of the lobbying entity engaged by the reporting entity identified in Item 4 to influence the covered federal action.
11. Enter the full names of the individual(s) performing services and include full address if different from 10 (a). Enter Last Name, First Name and Middle Initial (MI).
12. Enter the amount of compensation paid or reasonably expected to be paid by the reporting entity (Item 4) to the lobbying entity (Item 10). Indicate whether the payment has been made (actual) or will be made (planned). Check all boxes that apply. If this is a material change report, enter the cumulative amount of payment made or planned to be made.
13. Check all boxes that apply. If payment is made through an in-kind contribution, specify the nature and value of the in-kind payment.
14. Check all boxes that apply. If other, specify nature.
15. Provide a specific and detailed description of the services that the lobbyist has performed or will be expected to perform and the date(s) of any services rendered. Include all preparatory and related activity not just time spent in actual contact with federal officials. Identify the federal officer(s) or employee(s) contacted or the officer(s) employee(s) or Member(s) of Congress that were contacted.
16. Check whether or not a continuation sheet(s) is attached.
17. The certifying official shall sign and date the form, and print his/her name title and telephone number.

Public reporting burden for this collection of information is estimated to average 30-minutes per response, including time for reviewing instruction, searching existing data sources, gathering and maintaining the data needed, and completing and reviewing the collection of information. Send comments regarding the burden estimate or any other aspect of this collection of information, including suggestions for reducing this burden, to the Office of Management and Budget, Paperwork Reduction Project (0348-0046), Washington, D.C. 20503. SF-LLL-Instructions Rev. 06-04

EXHIBIT "C"CITY - SERVICES TO BE PROVIDED
TO CONSULTANT

1. Furnish the Consultant all in-house data which is pertinent to services to be performed by the Consultant and which is within the custody or control of the City, including, but not limited to, copies of record and off-record maps and other record and off-record property data, right-of-way maps and other right-of-way data, pending or proposed subject property land division and development application data, all newly developed and pertinent design and WORK specification data, and such other pertinent data which may become available to the City.
2. Provide timely review, processing, and reasonably expeditious approval of all submittals by the Consultant.
3. Provide timely City staff liaison with the Consultant when requested and when reasonably needed.

EXHIBIT "D"

TERMS OF PAYMENT

1. The Consultant's compensation shall not exceed \$ **TBD** .
2. The Consultant will obtain, and keep current during the term of this Agreement, the required City of Moreno Valley business license. Proof of a current City of Moreno Valley business license will be required prior to any payments by the City. Any invoice not paid because the proof of a current City of Moreno Valley business license has not been provided will not incur any fees, late charges, or other penalties. Complete instructions for obtaining a City of Moreno Valley business license are located at: <http://www.moval.org/biz-lic>.
3. The Consultant will electronically submit an invoice to the City along with documentation evidencing services completed to date as specified in the Request for Proposal. Progress payments will be made in accordance with the payment schedule outlined in the Request for Proposal, but in no case will progress payments be made to the Consultant more frequently than once per month. The progress payment is based on actual time and materials expended in furnishing authorized professional services during the preceding calendar month. At no time will the City pay for more services than have been satisfactorily completed and the City Engineer's determination of the amount due for any progress payment shall be final. The consultant will submit all original invoices to Accounts Payable staff at TechInfo-CapProj@moval.org. Accounts Payable questions can be directed to (951) 413-3130.
4. The Consultant agrees that City payments will be received via Automated Clearing House (ACH) Direct Deposit and that the required ACH Authorization form will be

completed prior to any payments by the City. Any invoice not paid because the completed ACH Authorization Form has not been provided will not incur any fees, late charges, or other penalties. The ACH Authorization Form is located at:

http://www.moval.org/city_hall/forms.shtml#bf

5. The minimum information required on all invoices is:
 - A. Vendor Name, Mailing Address, and Phone Number
 - B. Invoice Date
 - C. Vendor Invoice Number
 - D. City-provided Reference Number (e.g. WORK, Activity)
 - E. Detailed work hours by class title (e.g. Manager, Technician, or Specialist), services performed and rates, explicit portion of a contract amount, or detailed billing information that is sufficient to justify the invoice amount; single, lump amounts without detail are not acceptable.
6. The City shall pay the Consultant for all invoiced, authorized professional services within thirty (30) days of receipt of the invoice for same.



Rate Sheet

City of Moreno Valley Professional Consultant Senior Engineer Services (2023-020)

The following rate sheet will be valid for the duration of the contract (Calendar Years 2023-2026)

<u>Engineer/Scientist</u>	<u>Rate/Hour</u>
Alex Torres – Senior Engineer (On-Site)	\$184
Principal	\$343
Senior Project Manager	\$330
Project Manager	\$294
Technical Manager	\$265
Task Leader	\$239
Principal Engineer	\$224
Senior Engineer	\$205
Project Engineer	\$191
Staff Engineer	\$170
Assistant Engineer	\$127
Senior Environmental Scientist	\$203
Environmental Scientist	\$156
Environmental Analyst	\$114
 <u>Construction Services</u>	
Construction Manager	\$238
Senior Construction Inspector	\$175
Construction Inspector	\$165
 <u>Field Survey</u>	
Licensed Surveyor	\$228
3-Person Survey Crew	\$436
2-Person Survey Crew	\$356
 <u>Support Services</u>	
GIS Specialist	\$156
Senior Engineering Technician	\$125
Engineering Technician	\$109
CADD Designer	\$104
Project Coordinator	\$146
Graphic Designer	\$145
Administrative Assistant	\$137
 <u>General</u>	
Direct Expenses	Cost + 10%
Subcontract Services	Cost + 10%
Specialized Computer Applications (per hour)	\$15
Mileage	Current IRS Rate
B&W Photocopies (per page)	\$0.10
Color Photocopies (per page)	\$0.50

Rates for field equipment, health and safety equipment, and graphical supplies presented upon request.

Based on CWE maintaining General Liability Insurance for bodily injury and property damage with an aggregate limit of \$2,000,000 per occurrence. In the event the client desires additional coverage, CWE will, upon the client's written request, obtain additional insurance and adjust the above billing rates accordingly.

Attachment: Agreement with CWE (6330) : AUTHORIZATION TO AWARD AGREEMENTS FOR PROFESSIONAL CONSULTING SENIOR

EXHIBIT "E"

INSURANCE REQUIREMENTS

Minimum Scope of Insurance

Coverage shall be at least as broad as:

1. The most current version of Insurance Services Office (ISO) Commercial General Liability Coverage Form CG 00 01, which shall include insurance for "bodily injury," "property damage" and "personal and advertising injury" with coverage for premises and operations, products and completed operations, and contractual liability.
2. The most current version of Insurance Service Office (ISO) Business Auto Coverage Form CA 00 01, which shall include coverage for all owned, hired, and non-owned automobiles or other licensed vehicles (Code 1- Any Auto).
3. Workers' Compensation insurance as required by the California Labor Code and Employer's Liability Insurance.
4. Professional Liability (Errors and Omissions) insurance appropriate to Consultant's profession.

Minimum Limits of Insurance

Consultant shall maintain limits of liability of not less than:

1. General Liability:
 - \$1,000,000 per occurrence for bodily injury and property damage
 - \$1,000,000 per occurrence for personal and advertising injury
 - \$2,000,000 aggregate for products and completed operations
 - \$2,000,000 general aggregate
2. Automobile Liability:
 - \$1,000,000 per accident for bodily injury and property damage
3. Employer's Liability:
 - \$1,000,000 each accident for bodily injury
 - \$1,000,000 disease each employee
 - \$1,000,000 disease policy limit

Attachment: Agreement with CWE (6330 : AUTHORIZATION TO AWARD AGREEMENTS FOR PROFESSIONAL CONSULTING SENIOR

4. Professional Liability (Errors and Omissions):

\$1,000,000 per claim/occurrence
\$2,000,000 policy aggregate

Umbrella or Excess Insurance

In the event Consultant purchases an Umbrella or Excess insurance policy(ies) to meet the "Minimum Limits of Insurance," this insurance policy(ies) shall "follow form" and afford no less coverage than the primary insurance policy(ies).

Deductibles and Self-Insured Retentions

Consultant shall be responsible for payment of any deductibles contained in any insurance policy(ies) required hereunder and Consultant shall also be responsible for payment of any self-insured retentions. Any deductibles or self-insured retentions must be declared to, and approved by, the City Manager or his/her designee. At the option of the City Manager or his/her designee, either (i) the insurer shall reduce or eliminate such deductibles or self-insured retentions as respects The City of Moreno Valley, the City of Moreno Valley Community Services District, the Moreno Valley Housing Authority, and each of their officers, officials, employees, agents and volunteers; or (ii) Consultant shall provide a financial guarantee, satisfactory to the City Manager or his/her designee, guaranteeing payment of losses and related investigations, claim administration and defense expenses. At no time shall City be responsible for the payment of any deductibles or self-insured retentions.

Other Insurance Provisions

The General Liability and Automobile Liability insurance policies are to contain, or be endorsed to contain, the following provisions:

1. The City of Moreno Valley, the City of Moreno Valley Community Services District, the Moreno Valley Housing Authority, and each of their officers, officials, employees, agents and volunteers are to be covered as additional insureds.
2. The coverage shall contain no special limitations on the scope of protection afforded to the City of Moreno Valley, the City of Moreno Valley Community Services District, the Moreno Valley Housing Authority, and each of their officers, officials, employees, agents and volunteers.
3. Consultant's insurance coverage shall be primary and no contribution shall be required of City.

The Workers' Compensation insurance policy is to contain, or be endorsed to contain, the following provision: Consultant and its insurer shall waive any right of subrogation against the City of Moreno Valley, the City of Moreno Valley Community Services District, the Moreno Valley Housing Authority, and each of their officers, officials, employees, agents and volunteers.

If the Professional Liability (Errors and Omissions) insurance policy is written on a claims-made

form:

1. The retroactive date must be shown, and must be before the effective date of the Agreement or the commencement of work by Consultant.
2. Insurance must be maintained and evidence of insurance must be provided for at least 3 years after any expiration or termination of the Agreement or, in the alternative, the policy shall be endorsed to provide not less than a 3-year discovery period.
3. If coverage is canceled or non-renewed, and not replaced with another claims-made policy form with a retroactive date prior to the effective date of the Agreement or the commencement of work by Consultant, Consultant must purchase extended reporting coverage for a minimum of 3 years following the expiration or termination of the Agreement.
4. A copy of the claims reporting requirements must be submitted to City for review.
5. These requirements shall survive expiration or termination of the Agreement.

All policies of insurance required hereunder shall be endorsed to provide that the coverage shall not be cancelled, non-renewed, reduced in coverage or in limits except after 30 calendar day written notice by certified mail, return receipt requested, has been given to City. Upon issuance by the insurer, broker, or agent of a notice of cancellation, non-renewal, or reduction in coverage or in limits, Consultant shall furnish City with a new certificate and applicable endorsements for such policy(ies). In the event any policy is due to expire during the work to be performed for City, Consultant shall provide a new certificate, and applicable endorsements, evidencing renewal of such policy not less than 15 calendar days prior to the expiration date of the expiring policy.

Acceptability of Insurers

All policies of insurance required hereunder shall be placed with an insurance company(ies) admitted by the California Insurance Commissioner to do business in the State of California and rated not less than "A-VII" in Best's Insurance Rating Guide; or authorized by the City Manager or his/her designee.

Verification of Coverage

Consultant shall furnish City with all certificate(s) and **applicable endorsements** effecting coverage required hereunder. All certificates and **applicable endorsements** are to be received and approved by the City Manager or his/her designee prior to City's execution of the Agreement and before work commences.



Report to City Council

TO: Mayor and City Council

FROM: Melissa Walker, Public Works Director/City Engineer

AGENDA DATE: October 17, 2023

TITLE: APPROVE RESOLUTION NO. 2023-XX AUTHORIZING SUBMITTAL OF APPLICATION(S) FOR ALL CALRECYCLE GRANTS FOR WHICH THE CITY OF MORENO VALLEY IS ELIGIBLE

RECOMMENDED ACTION

Recommendation:

1. Adopt the proposed Resolution No. 2023-XX approving submittal of application(s) for all CalRecycle grants for which the City of Moreno Valley is eligible.

SUMMARY

This report recommends adoption of Resolution No. 2023-XX approving submittal of potential applications for all CalRecycle grants for which the City is eligible to obtain funding for street pavement rehabilitation and related improvements.

DISCUSSION

The CalRecycle administers the Rubberized Pavement Grant Program and other various grants. A resolution approved by the applicant's governing body is required to support the recent preliminary submittal of a CalRecycle Rubberized Pavement Grant application, and to allow for the future submittal of CalRecycle grant applications. Adoption of the proposed resolution will ensure that the City's application complies with grant requirements.

The rubberized pavement grant reimburses up to 40% of the differential cost between conventional asphalt concrete and rubberized asphalt concrete. The total grant amount request is approximately \$250,000 which would supplement City funds for the upcoming Citywide Pavement Rehabilitation Program – FY 2023/24 and 24/25. This is the

maximum amount that Moreno Valley can apply for as the grant amount reduces year after year for entities that have received funding in the past.

Approval of the recommended actions would result in potential grant funding for public improvements and support Objective 4 of the Momentum MoVal Strategic Plan: “Manage and maximize Moreno Valley’s public infrastructure to ensure an excellent quality of life, develop and implement innovative, cost-effective infrastructure maintenance programs, public facilities management strategies, and capital improvement programming and project delivery.”

ALTERNATIVES

1. Adopt the proposed resolution approving submittal of application(s) for all CalRecycle grants for which the City of Moreno Valley is eligible and designating authority to administer all such grants. This will ensure compliance with CalRecycle grant requirements related to the recent Rubberized Pavement Grant application and allow the City to submit for all CalRecycle grants for which the City is eligible over the next five years.
2. Do not adopt the proposed resolution approving submittal of application(s) for all CalRecycle grants for which the City of Moreno Valley is eligible and designating authority to administer such grants. This may negatively impact the City’s eligibility to have the City’s recent Rubberized Pavement Grant application approved and receive grant funds from the Rubberized Pavement Grant Program.

FISCAL IMPACT

There is a potential grant revenue reimbursement for public road improvements for an estimated total grant award of up to \$250,000 for fiscal years 2023-24 and 2024-25 pavement repairs.

NOTIFICATION

Publication of the City Council Agenda.

PREPARATION OF STAFF REPORT

Prepared By:
Ricky Carrillo
Associate Engineer

Department Head Approval:
Melissa Walker, P.E.
Public Works Director/ City Engineer

Concurred By:
Quang Nguyen, P.E.
Principal Engineer

CITY COUNCIL GOALS

Public Facilities and Capital Projects. Ensure that needed public facilities, roadway improvements, and other infrastructure improvements are constructed and maintained.

Positive Environment. Create a positive environment for the development of Moreno Valley's future.

Community Image, Neighborhood Pride and Cleanliness. Promote a sense of community pride and foster an excellent image about our City by developing and executing programs which will result in quality development, enhanced neighborhood preservation efforts, including home rehabilitation and neighborhood restoration.

CITY COUNCIL STRATEGIC PRIORITIES

- 1. Economic Development
- 2. Public Safety
- 3. Library
- 4. Infrastructure
- 5. Beautification, Community Engagement, and Quality of Life
- 6. Youth Programs

ATTACHMENTS

To view large attachments, please click your “bookmarks”  on the left hand side of this document for the necessary attachment.

- 1. Resolution 2023-XX

APPROVALS

Budget Officer Approval	<u>✓ Approved</u>	10/09/23 8:57 AM
City Attorney Approval	<u>✓ Approved</u>	
City Manager Approval	<u>✓ Approved</u>	10/09/23 9:02 AM

RESOLUTION NO. 2023-XX

A RESOLUTION OF THE CITY COUNCIL OF THE CITY OF MORENO VALLEY, CALIFORNIA APPROVING SUBMITTAL OF APPLICATION(S) FOR ALL CALRECYCLE GRANTS FOR WHICH THE CITY OF MORENO VALLEY IS ELIGIBLE

WHEREAS, Public Resources Code sections 48000 et seq., 14581, and 42023.1(g), authorize the Department of Resources Recycling and Recovery (CalRecycle) to administer various grant and payment programs in furtherance of the State of California's (state) efforts to reduce, recycle and reuse solid waste generated in the state thereby preserving landfill capacity and protecting public health and safety and the environment; and

WHEREAS, in furtherance of this authority, CalRecycle is required to establish procedures governing the administration of the payment programs; and administration of the application, awarding, and management of the grant programs; and

WHEREAS, CalRecycle's procedures for administering payment and grant programs require, among other things, an applicant's governing body to declare by resolution certain authorizations related to the administration of the payment and grant program; and

NOW, THEREFORE, BE IT RESOLVED that the City Council of the City of Moreno Valley, California, is authorized to submit an application to CalRecycle for any and all grant and payment programs offered; and

BE IT FURTHER RESOLVED that the City Manager, and/or the Public Works Director/City Engineer, are hereby authorized and empowered to execute in the name of the City of Moreno Valley all documents, including but not limited to, applications, agreements, amendments and requests for payment, necessary to secure funds and implement the approved grant or payment project; and

BE IT FURTHER RESOLVED that these authorizations are effective five (5) years from the date of adoption of this Resolution.

1
Resolution No. 2023-XX
Date Adopted: October 17, 2023

Attachment: Resolution 2023-XX (6408 : APPROVE RESOLUTION NO. 2023-xx AUTHORIZING SUBMITTAL OF APPLICATION(S) FOR ALL

APPROVED AND ADOPTED this 17th day of October, 2023.

Mayor of the City of Moreno Valley

ATTEST:

City Clerk

APPROVED AS TO FORM:

City Attorney

2
Resolution No. 2023-XX
Date Adopted: October 17, 2023

Attachment: Resolution 2023-XX (6408 : APPROVE RESOLUTION NO. 2023-xx AUTHORIZING SUBMITTAL OF APPLICATION(S) FOR ALL

RESOLUTION JURAT

STATE OF CALIFORNIA)
COUNTY OF RIVERSIDE) ss.
CITY OF MORENO VALLEY)

I, Jane Halstead, City Clerk of the City of Moreno Valley, California, do hereby certify that Resolution No. 2023-XX was duly and regularly adopted by the City Council of the City of Moreno Valley at a regular meeting thereof held on the 17th day of October, 2023 by the following vote:

AYES:

NOES:

ABSENT:

ABSTAIN:

(Council Members, Mayor Pro Tem and Mayor)

City Clerk

(SEAL)

3
Resolution No. 2023-XX
Date Adopted: October 17, 2023

Attachment: Resolution 2023-XX (6408 : APPROVE RESOLUTION NO. 2023-xx AUTHORIZING SUBMITTAL OF APPLICATION(S) FOR ALL



Report to City Council

TO: Mayor and City Council

FROM: Brian Mohan, Assistant City Manager

AGENDA DATE: October 17, 2023

TITLE: ADOPTION OF COUNTY ORDINANCE NUMBER 987 REGARDING UNLAWFUL POSSESSION OF CATALYTIC CONVERTERS (ORD. NO. XXXX)

RECOMMENDED ACTION

Recommendations: That the City Council:

1. Introduce and conduct first reading of Ordinance No. XXXX, amending Title 11 of the City of Moreno Valley Municipal Code, adding Chapter 11.97, adopting by reference Riverside County Ordinance No. 987; and
2. Schedule a public hearing to receive public input regarding adoption of Ordinance No. XXXX on November 21, 2023, and consider adoption of Ordinance No. XXXX upon conclusion of said public hearing.

SUMMARY

Pursuant to California Government Code 50022.2, adoption of certain ordinances by reference requires specific procedural steps. If the City Council approves the first reading of the ordinance, the City Council should then set a date and time for public hearing regarding adoption of the ordinance; City must publish a public hearing notice under Government Code 6066; and, after said public hearing, the City Council may then amend, adopt or reject adoption of the ordinance.

DISCUSSION

The Board of Supervisors of Riverside County finds that the theft of catalytic converters has been an increasing problem in Riverside County in recent years. The external location of catalytic converters and the use of valuable precious metals, including rhodium, palladium and platinum, in catalytic converters makes these devices a target

for thieves. Individuals in possession of stolen catalytic converters often recycle them for substantial profit, while victims of these thefts suffer the consequences of paying thousands of dollars in repairs, the inconvenience of repairing their vehicles, and feeling unsafe in the community. Finding the victim of these crimes is extremely difficult due to the manner in which the catalytic converter thefts occur and lack of identifying markers on catalytic converters to link a stolen catalytic converter to the victim. The inability to identify the victims of catalytic converter thefts can inhibit the ability to successfully prosecute individuals for the thefts. This ordinance is necessary to provide the County a means to protect the public, deter this criminal activity and promote a more productive use of Riverside County resources.

Catalytic converter theft is an increasing problem within Riverside County and causes significant financial damage to the victims. The purpose and intent of this ordinance is to curb the theft of catalytic converters throughout the County and to provide the County with reasonable means to address the impact on the community and the victims posed by increasing catalytic converter thefts.

Adoption of this Ordinance by reference will enable Riverside County the ability to enforce their Ordinance in the City of Moreno Valley.

ALTERNATIVES

The City Council has following alternatives to consider:

1. Introduce and conduct the first reading of the proposed Ordinance adopting by reference Riverside County Ordinance No. 987, pursuant to California Government Code 50022.2, and schedule a public hearing to receive public input regarding adoption of proposed ordinance as outlined in this report and consider adoption of said ordinance. *Staff recommends this alternative.*
2. Do not introduce, nor pursue, the adoption of the proposed Ordinance adopting by reference Riverside County Ordinance No. 987 as outlined in this report. *Staff does not recommend this alternative.*

FISCAL IMPACT

There is no fiscal impact with the adoption of this Ordinance.

NOTIFICATION

Publication of the Agenda.

PREPARATION OF STAFF REPORT

Prepared By:
Brian Mohan
Assistant City Manager/CFO/Treasurer

Department Head Approval:
Brian Mohan
Assistant City Manager/CFO/Treasurer

CITY COUNCIL GOALS

Public Safety. Provide a safe and secure environment for people and property in the community, control the number and severity of fire and hazardous material incidents, and provide protection for citizens who live, work and visit the City of Moreno Valley.

Positive Environment. Create a positive environment for the development of Moreno Valley's future.

CITY COUNCIL STRATEGIC PRIORITIES

- 1. Economic Development
- 2. Public Safety
- 3. Library
- 4. Infrastructure
- 5. Beautification, Community Engagement, and Quality of Life
- 6. Youth Programs

ATTACHMENTS

To view large attachments, please click your “bookmarks”  on the left hand side of this document for the necessary attachment.

- 1. 10.17.23 ORDINANCE ADOPTING BY REFERENCE RIVERSIDE COUNTY ORDINANCES 987 CATALYTIC CONVERTERS(10.11.23)

APPROVALS

Budget Officer Approval	<u>✓ Approved</u>	10/09/23 2:06 PM
City Attorney Approval	<u>✓ Approved</u>	
City Manager Approval	<u>✓ Approved</u>	10/09/23 2:35 PM

ORDINANCE NO. ____

AN ORDINANCE OF THE CITY COUNCIL OF THE CITY OF MORENO VALLEY, CALIFORNIA, ADDING CHAPTER 11.97 (“UNLAWFUL POSSESSION OF A CATALYTIC CONVERTER”) TO TITLE 11 (“PEACE, MORALS, AND SAFTETY”) OF THE MORENO VALLEY MUNICIPAL CODE, ADOPTING BY REFERENCE RIVERSIDE COUNTY ORDINANCE NO. 987, “AN ORDINANCE OF THE COUNTY OF RIVERSIDE RELATING TO THE UNLAWFUL POSSESSION OF A CATALYTIC CONVERTER”

WHEREAS, the City of Moreno Valley (the “City”) is a general law city organized pursuant to Article XI of the California Constitution; and

WHEREAS, in 2022, the Governor signed into law Senate Bill 1087, amending Section 21610 of the California Business and Professions Code and Section 10852.5 of the California Vehicle Code, prohibiting any person from purchasing a used catalytic converter from anybody other than certain specified sellers; prohibited core recycler from purchasing a catalytic converter from anybody other than specified sellers; and making a violation of the provisions to be an infraction, punishable by a fine; and

WHEREAS, the County of Riverside (“County”) adopted Ordinance No. 987, an “Ordinance of the County of Riverside Relating to the Unlawful Possession of a Catalytic Converter,” (“Ordinance 987”), to curb the theft of catalytic converters throughout the County and to provide the Count with reasonable means to address the impact on the community and the victims posed by increasing catalytic converter thefts; and

WHEREAS, City staff recommends that the City adopt and incorporate by reference Ordinance 987 into Title 11 (“Peace, Morals, and Safety”) of the Moreno Valley Municipal Code, as set forth herein, providing the County a means to protect the public and deter certain criminal activity.

NOW THEREFORE, THE CITY COUNCIL OF THE CITY OF MORENO VALLEY DOES ORDAIN AS FOLLOWS:

Section 1. RECITALS

That the above recitals are true and correct and are incorporated as though fully set forth herein.

Section 2. ADOPTION OF RIVERSIDE COUNTY ORDINANCE NO. 987 BY REFERENCE, ADDING CHAPTER 11.97 (“UNLAWFUL POSSESSION OF A CATALYTIC CONVERTER”) TO TITLE 11 OF THE MORENO VALLEY MUNICIPAL CODE

A. That the City Council hereby adopts Riverside County Ordinance No. 987, an “Ordinance of the County of Riverside Relating to the Unlawful Possession of a Catalytic

Attachment: 10.17.23 ORDINANCE ADOPTING BY REFERENCE RIVERSIDE COUNTY ORDINANCES 987 CATALYTIC CONVERTERS(10.11.23)

Converter” as may be amended, which is incorporated by reference as though set forth at length herein, upon the effective date of this ordinance.

B. That Chapter 11.97 (“Unlawful Possession of a Catalytic Converter”) is hereby added to Title 11 of the Moreno Valley Municipal Code as follows:

11.97 RIVERSIDE COUNTY ORDINANCE NO. 987 UNLAWFUL POSSESSION OF A CATALYTIC CONVERTER

11.97.010 Adopted.

Riverside County Ordinance No. 987, an “Ordinance of the County of Riverside Relating to the Unlawful Possession of a Catalytic Converter,” (“Ordinance No. 987”) as may be amended in the future, is adopted and made a part of this chapter by reference.

11.97.020 Definitions

All words and terms used herein without definition shall have the meanings assigned to them in Ordinance No. 987.

11.97.030 Violations and Enforcement

A. Misdemeanor Penalty. Any person who violates any provision of this ordinance is guilty of a misdemeanor, and upon conviction shall be punished by a fine not exceeding one thousand dollars (\$1,000), or by imprisonment in the county jail for a term not exceeding one year, or by both. Upon any second or subsequent conviction of the offense, the person shall be punished by the penalties of a fine of one thousand dollars (\$1,000) and by imprisonment in the County jail for one year.

B. State Penalties Apply. Nothing in this ordinance shall be intended to limit any of the penalties provided for under California law, including but not limited to the Penal Code, with regard to the sale, use, possession, delivery, and/or receipt of catalytic converters.

C. Administrative Civil Penalty. In addition to any other penalties provided by law, whenever an Enforcement Officer determines a violation of this ordinance has occurred, the Enforcement Officer shall have the authority to issue an administrative citation with an administrative civil penalty to any person responsible for the violation. Any administrative civil penalty shall be one thousand dollars (\$1,000) for the first offense, two thousand dollars (\$2,000) for the second offense within thirty-six (36) months, and five thousand dollars (\$5,000) for each subsequent offense within thirty-six (36) months. The administrative citation shall contain the following information: (1) date, location and approximate time the violation was observed; (2) the amount of the administrative civil penalty imposed for the violation; (3) instructions for the payment of the administrative civil penalty, the time period by which it shall be paid, and the consequences of failure to pay the administrative civil penalty within this time; (4) instructions on how to appeal the administrative citation; and (5) the signature of the Enforcement Officer. The failure of the administrative citation to set forth

all required contents shall not affect the validity of the administrative citation or any proceedings to enforce said citation. The administrative civil penalty may be imposed via the administrative process set forth in this ordinance or may be imposed by the court if the violation requires court enforcement without an administrative process.

D. **Separate Offenses.** Acts, omissions, or conditions in violation of this ordinance that continue, exist, or occur on more than one day constitute separate violations on each day. Violations continuing, existing, or occurring on the service date, the effective date, and each day between the service date and the effective date are separate violations. A person is guilty of a separate offense for each and every day or portion thereof during which he or she commits, continues, or permits a violation of this ordinance. A person is deemed guilty of a separate offense for each and every violation of this ordinance, or any portion thereof. Likewise, a person shall be deemed guilty of a separate offense for each and every catalytic converter in the person's possession that is not attached to a vehicle unless the person has a valid proof of ownership of the catalytic converter.

E. **Non-Exclusive Remedies and Penalties.** All remedies and penalties for violations of the prohibitions in this ordinance shall be cumulative and not exclusive. Enforcement by use of any administrative, criminal or civil action, citation or administrative proceeding or abatement remedy does not preclude the use of additional citations or other remedies as authorized by other ordinance or law. Enforcement remedies may be employed concurrently or consecutively. Conviction and punishment of or enforcement against any person hereunder shall not relieve such person from the responsibility of correcting, removing or abating a violation, nor prevent the enforced correction, removal or abatement thereof.

Section 4. ENFORCEMENT AUTHORITY

That the City Council hereby delegates the authority to the County to administer and enforce the provisions of Ordinance No. 987, as adopted and incorporated herein, within the jurisdictional boundaries of the City, which shall not preclude the City from taking any enforcement action as it deems necessary at any time in accordance with applicable law.

Section 5. SEVERABILITY

That the City Council declares that, should any provision, section, paragraph, sentence or word of this ordinance be rendered or declared invalid by any final court action in a court of competent jurisdiction or by reason of any preemptive legislation, the remaining provisions, sections, paragraphs, sentences or words of this ordinance as hereby adopted shall remain in full force and effect.

Section 6. REPEAL OF CONFLICTING PROVISIONS

That all the provisions of the Moreno Valley Municipal Code as heretofore adopted by the City of Moreno Valley that are in conflict with the provisions of this ordinance are hereby repealed.

Section 7. EFFECTIVE DATE

That this ordinance shall take effect thirty (30) days after its adoption.

Section 8. AMENDING OF BAIL SCHEDULE

That the City Attorney is hereby directed to determine whether this ordinance necessitates amendment of the City's Bail Schedule and to cause such necessary amendments to be made and filed with the local branches of the Superior Court of the County of Riverside.

Section 9. CERTIFICATION

That the City Clerk shall certify to the passage of this ordinance and shall cause the same to be published according to law.

[REMAINDER OF THIS PAGE INTENTIONALLY LEFT BLANK]

The foregoing Ordinance was approved and adopted at a meeting of the City Council held on _____, 2023, by the following vote:

- Ayes:
- Noes:
- Abstain:
- Absent:

Ulises Cabrera, Mayor

ATTEST:

Jane Halstead, City Clerk

APPROVED AS TO FORM:

Steven B. Quintanilla, City Attorney

Attachment: 10.17.23 ORDINANCE ADOPTING BY REFERENCE RIVERSIDE COUNTY ORDINANCES 987 CATALYTIC CONVERTERS(10.11.23)