

**GEOTECHNICAL INVESTIGATION
PROPOSED WAREHOUSE**

14050 Day Street
Moreno Valley, California
for
First Industrial Realty Trust, Inc.



**SOUTHERN
CALIFORNIA
GEOTECHNICAL**
A California Corporation



**SOUTHERN
CALIFORNIA
GEOTECHNICAL**
A California Corporation

February 15, 2022

First Industrial Realty Trust, Inc.
898 N. Pacific Coast Highway. STE 175
El Segundo, CA 90245

Attention: Mr. Michael Goodwin
Director of Development

Project No.: **21G291-1**

Subject: **Geotechnical Investigation**
Proposed Warehouse
14050 Day Street
Moreno Valley, California

Dear Mr. Goodwin:

In accordance with your request, we have conducted a geotechnical investigation at the subject site. We are pleased to present this report summarizing the conclusions and recommendations developed from our investigation.

We sincerely appreciate the opportunity to be of service on this project. We look forward to providing additional consulting services during the course of the project. If we may be of further assistance in any manner, please contact our office.

Respectfully Submitted,

SOUTHERN CALIFORNIA GEOTECHNICAL, INC.

A handwritten signature in blue ink, appearing to read "Joseph Lozano Leon".

Joseph Lozano Leon
Staff Engineer

A handwritten signature in blue ink, appearing to read "Robert G. Trazo".

Robert G. Trazo, GE 2655
Principal Engineer



Distribution: (1) Addressee

TABLE OF CONTENTS

1.0 EXECUTIVE SUMMARY	1
2.0 SCOPE OF SERVICES	3
3.0 SITE AND PROJECT DESCRIPTION	4
3.1 Site Conditions	4
3.2 Proposed Development	4
4.0 SUBSURFACE EXPLORATION	6
4.1 Scope of Exploration/Sampling Methods	6
4.2 Geotechnical Conditions	6
5.0 LABORATORY TESTING	8
6.0 CONCLUSIONS AND RECOMMENDATIONS	10
6.1 Seismic Design Considerations	10
6.2 Geotechnical Design Considerations	13
6.3 Site Grading Recommendations	16
6.4 Construction Considerations	20
6.5 Foundation Design and Construction	22
6.6 Floor Slab Design and Construction	23
6.7 Exterior Flatwork Design and Construction	24
6.8 Retaining Wall Design and Construction	25
6.9 Pavement Design Parameters	27
7.0 GENERAL COMMENTS	30
8.0 REFERENCES	31
APPENDICES	
A Plate 1: Site Location Map Plate 2: Boring Location Plan	
B Boring Logs	
C Laboratory Test Results	
D Grading Guide Specifications	
E Seismic Design Parameters	
F Liquefaction Evaluation Spreadsheets	

1.0 EXECUTIVE SUMMARY

Presented below is a brief summary of the conclusions and recommendations of this investigation. Since this summary is not all inclusive, it should be read in complete context with the entire report.

Geotechnical Design Considerations

- The Riverside County GIS website indicates that the site is located in a designated high to moderate liquefaction susceptibility. Therefore, the scope of this investigation included a detailed liquefaction evaluation in order to determine the site-specific liquefaction potential.
- Our site-specific liquefaction evaluation indicates that the on-site soils are not subject to liquefaction during the design seismic event. No design considerations related to liquefaction are considered warranted for this project.
- All of the borings encountered artificial fill materials, extending to depths of 4½ to 5½± feet below the existing site grades. The fill soils possess varying strengths and densities, and are considered to represent undocumented fill. These soils, in their present condition, are not considered suitable for support of the foundation loads of the new structure.

Site Preparation

- Demolition of the existing structure, including foundations, floor slab, pavements, concrete flatwork, and any subsurface improvements, which will not be utilized as part of the new development, will be required. Debris resulting from demolition activities should be disposed of off-site in accordance with local regulations. Alternatively, concrete and asphalt debris may be pulverized to a maximum 2-inch particle size, well mixed with the on-site sands, and incorporated into new structural fills or it may be crushed and made into crushed miscellaneous base (CMB), if desired.
- Initial site stripping should include removal of the surficial vegetation from the site. Stripping should include native grass, weeds, shrubs and trees. Root systems associated with the trees should be removed in their entirety, and the resultant excavations should be backfilled with compacted structural fill soils. These materials should be properly disposed of off-site.
- The proposed building pad area should be overexcavated to a depth of at least 3 feet below existing grade and to a depth of at least 3 feet below proposed pad grade, whichever is deeper. Overexcavation within the new foundation areas is recommended to extend to a depth of at least 2 feet below proposed foundation bearing grade.
- After overexcavation has been completed, the subgrade soils should be evaluated by the geotechnical engineer to identify any additional soils that should be overexcavated. The resulting subgrade should then be scarified to a depth of 12 inches, moisture conditioned or air dried to 2 to 4 percent above optimum, and recompacted to at least 90 percent of the ASTM D-1557 maximum dry density. The previously excavated soils may then be replaced as compacted structural fill.
- The new pavement and flatwork subgrade soils are recommended to be scarified to a depth of 12± inches, moisture conditioned and recompacted to at least 90 percent of the ASTM D-1557 maximum dry density.

Building Foundations

- Spread footing foundations, supported in newly placed structural fill soils.
- Maximum, net allowable soil bearing pressure: 2,500 lbs/ft².
- Reinforcement consisting of at least four (4) No. 5 rebar (2 top and 2 bottom) in strip footings.
- Additional reinforcement may be necessary for structural considerations.

Building Floor Slab

- Conventional Slab on Grade, at least 6 inches thick
- Modulus of Subgrade Reaction: k = 100 psi/in
- Minimum slab reinforcement: Reinforcement of the floor slab should consist of No. 3 bars at 18-inches on center in both directions due to presence of low expansive soils.
- The actual thickness and reinforcement of the floor slab should be determined by the structural engineer.

Pavements

ASPHALT PAVEMENTS (R = 30)					
Materials	Thickness (inches)				
	Auto Parking and Auto Drive Lanes (TI = 4.0 to 5.0)	Truck Traffic			
		TI = 6.0	TI = 7.0	TI = 8.0	TI = 9.0
Asphalt Concrete	3	3½	4	5	5½
Aggregate Base	6	8	10	11	13
Compacted Subgrade	12	12	12	12	12

PORTLAND CEMENT CONCRETE PAVEMENTS (R = 30)				
Materials	Thickness (inches)			
	Autos and Light Truck Traffic (TI = 6.0)	Truck Traffic		
		(TI =7.0)	(TI =8.0)	(TI =9.0)
PCC	5	5½	6½	8
Compacted Subgrade (95% minimum compaction)	12	12	12	12

2.0 SCOPE OF SERVICES

The scope of services performed for this project was in accordance with our Proposal No. 21P518, dated December 23, 2021. The scope of services included a visual site reconnaissance, subsurface exploration, field and laboratory testing, and geotechnical engineering analysis to provide criteria for preparing the design of the building foundations, building floor slab, and parking lot pavements along with site preparation recommendations and construction considerations for the proposed development. Based on the location of this site, the geotechnical investigation also included a site-specific liquefaction evaluation. The evaluation of the environmental aspects of this site was beyond the scope of services for this geotechnical investigation.

3.0 SITE AND PROJECT DESCRIPTION

3.1 Site Conditions

The subject site is located on the east side of Day Street, 690± feet south of the intersection of Day Street and Alessandro Boulevard in Moreno Valley, California. The site is also referenced by the street address 14050 Day Street. The site is bounded to the west by Day Street, and to the south, east and north by industrial/commercial buildings. The general location of the site is illustrated on the Site Location Map, included as Plate 1 in Appendix A of this report.

The subject site consists of a near rectangular-shaped parcel, 8.01± acres in size. The site is currently developed with an industrial building, 65,000± ft² in size, located in the west-central area of the site. The building is a single-story structure of metal frame construction, and assumed to be supported on conventional shallow foundations with a concrete slab-on-grade floor. Silos and above ground storage tanks (AST's) are located immediately north of the building. Some large trees are present in the landscaped area immediately southeast from the building. The building is generally surrounded by asphaltic concrete (AC) pavements in the parking and drive lanes, and Portland cement concrete (PCC) pavements in the product storage areas in the northern and southern areas of the site. The existing pavements are in poor to fair condition, with moderate to severe cracking throughout. Earthen swales are present in area along the western and southern property lines.

Detailed topographic information was not available at the time of this report. Based on elevations obtained from Google Earth and visual observations made at the time of the subsurface investigation, the overall site generally slopes downward to the south at a gradient of less than 1 percent.

3.2 Proposed Development

A preliminary site plan, identified as Scheme 01 and prepared by RGA, for the proposed development was provided to our office by the client. Based on this plan, the subject site will be developed with a 163,242± ft² warehouse, located in the western portion of the site. Dock-high doors will be constructed along a portion of the east building wall. The proposed building is expected to be surrounded by AC pavements in the parking and drive areas, PCC pavements in the loading dock area, and concrete flatwork and landscaped planters throughout the site.

Detailed structural information has not been provided. It is assumed that the new building will be a single-story structure of tilt-up concrete construction, supported on a conventional shallow foundation system with a concrete slab-on-grade floor. Based on the assumed construction, maximum column and wall loads are expected to be on the order of 100 kips and 4 to 7 kips per linear foot, respectively.

No significant amounts of below-grade construction, such as basements or crawl spaces, are

expected to be included in the proposed development. Based on the assumed topography, cuts and fills of up to 3± feet are expected to be necessary to achieve the proposed building pad grades. It should be noted that this estimate does not include any remedial grading recommendations which are presented in a subsequent section of this report.

4.0 SUBSURFACE EXPLORATION

4.1 Scope of Exploration/Sampling Methods

The subsurface exploration conducted for this project consisted of five (5) borings (identified as Boring Nos. B-1 through B-5) advanced to depths of 20 to 50± feet below the existing site grades. Two of these borings were advanced to a depth of 50± feet as a part of the liquefaction evaluation. All of the borings were logged during drilling by a member of our staff.

The borings were advanced with hollow-stem augers, by a conventional truck-mounted drilling rig. Representative bulk and relatively undisturbed soil samples were taken during drilling. Relatively undisturbed soil samples were taken with a split barrel "California Sampler" containing a series of one inch long, 2.416± inch diameter brass rings. This sampling method is described in ASTM Test Method D-3550. In-situ samples were also taken using a 1.4± inch inside diameter split spoon sampler, in general accordance with ASTM D-1586. Both of these samplers are driven into the ground with successive blows of a 140-pound weight falling 30 inches. The blow counts obtained during driving are recorded for further analysis. Bulk samples were collected in plastic bags to retain their original moisture content. The relatively undisturbed ring samples were placed in molded plastic sleeves that were then sealed and transported to our laboratory.

The approximate locations of the borings are indicated on the Boring Location Plan, included as Plate 2 in Appendix A of this report. The Boring Logs, which illustrate the conditions encountered at the boring locations, as well as the results of some of the laboratory testing, are included in Appendix B.

4.2 Geotechnical Conditions

Pavements

Boring No. B-1 was drilled within the existing PCC pavements. The pavement section at this location consists of 7± inches of unreinforced PCC with no discernible layer of underlying aggregate base. Boring Nos. B-2, B-3, B-4 and B-5 were drilled within the existing AC pavements. The pavement sections at these locations consist of 1 to 3± inches of AC, underlain by 4 to 5± inches of aggregate base. A Petromat geotextile material was clearly observed between the AC and base sections at Boring Nos. B-2 and B-5.

Artificial Fill

Artificial fill soils were encountered beneath the existing pavements at all of the boring locations, extending to depths of 4½ to 5½± feet below the existing site grades. The fill soils generally consist of loose to dense silty sands and clayey sands. The fill soils possess a disturbed and

mottled appearance, and some samples possess debris such as concrete fragments, resulting in their classification as artificial fill.

Alluvium

Native alluvial soils were encountered beneath the fill soils at all of the boring locations, extending to at least the maximum depth explored of 50± feet below the existing site grades. The alluvial soils generally consist of stiff to very stiff sandy clays, silty clays and clayey silts, and medium dense to dense clayey sands and silty sands, with occasional medium dense to very dense well graded sands and medium dense sandy silts.

Groundwater

Free water was encountered during drilling at Boring Nos. B-1 and B-4 at depths of 32 and 27± feet below the ground surface, respectively. Delayed groundwater level readings, approximately 3 hours after the completion of drilling, were taken within the inside of the augers at these boring locations. These readings indicated that the groundwater was at depths of 21½ and 23± feet, respectively. Therefore, the static groundwater table is considered to have been present at depths of 21½ and 23± feet below the existing site grades at the time of subsurface exploration.

As part of our research, we reviewed available groundwater data in order to determine the historic high groundwater level for the site. The primary reference used to determine the historic groundwater depths in this area is the Western Municipal Water District and the San Bernardino Valley Water Conservation District Cooperative Well Measuring Program. High water level from the nearest well is included below:

State Well ID	Approximate Distance from Subject Site	Measuring Point Elevation MSL (feet)	High Water Level MSL (feet)
03S/04W-10Q	< 2640 feet	1532.67	1518.29

Based on the well information provided in the above table, the high groundwater level is 14± feet below the ground surface. Therefore, a groundwater depth of 14± feet is considered to be conservative with respect to the more recent site conditions.

5.0 LABORATORY TESTING

The soil samples recovered from the subsurface exploration were returned to our laboratory for further testing to determine selected physical and engineering properties of the soils. The tests are briefly discussed below. It should be noted that the test results are specific to the actual samples tested, and variations could be expected at other locations and depths.

Classification

All recovered soil samples were classified using the Unified Soil Classification System (USCS), in accordance with ASTM D-2488. The field identifications were then supplemented with additional visual classifications and/or by laboratory testing. The USCS classifications are shown on the Boring Logs and are periodically referenced throughout this report.

Dry Density and Moisture Content

The density has been determined for selected relatively undisturbed ring samples. These densities were determined in general accordance with the method presented in ASTM D-2937. The results are recorded as dry unit weight in pounds per cubic foot. The moisture contents are determined in accordance with ASTM D-2216, and are expressed as a percentage of the dry weight. These test results are presented on the Boring Logs.

Consolidation

Selected soil samples were tested to determine their consolidation potential, in accordance with ASTM D-2435. The testing apparatus is designed to accept either natural or remolded samples in a one-inch high ring, approximately 2.416 inches in diameter. Each sample is then loaded incrementally in a geometric progression and the resulting deflection is recorded at selected time intervals. Porous stones are in contact with the top and bottom of the sample to permit the addition or release of pore water. The samples are typically inundated with water at an intermediate load to determine their potential for collapse or heave. The results of the consolidation testing are plotted on Plates C-1 through C-4 in Appendix C of this report.

Maximum Dry Density and Optimum Moisture Content

One representative bulk sample has been tested for its maximum dry density and optimum moisture content. The results have been obtained using the Modified Proctor procedure, per ASTM D-1557 and are presented on Plate C-5 in Appendix C of this report. This test is generally used to compare the in-situ densities of undisturbed field samples, and for later compaction testing. Additional testing of other soil types or soil mixes may be necessary at a later date.

Expansion Index

The expansion potential of the on-site soils was determined in general accordance with ASTM D-4829. The testing apparatus is designed to accept a 4-inch diameter, 1-in high, remolded sample. The sample is initially remolded to 50 ± 1 percent saturation and then loaded with a surcharge

equivalent to 144 pounds per square foot. The sample is then inundated with water, and allowed to swell against the surcharge. The resultant swell or consolidation is recorded after a 24-hour period. The results of the expansion index (EI) testing are as follows:

<u>Sample Identification</u>	<u>Expansion Index</u>	<u>Expansive Potential</u>
B-3 @ 0 to 5 feet	33	Low
B-4 @ 0 to 5 feet	21	Low

Soluble Sulfates

One representative sample of the near-surface soil was submitted to a subcontracted analytical laboratory for determination of soluble sulfate content. Soluble sulfates are naturally present in soils, and if the concentration is high enough, can result in degradation of concrete which comes into contact with these soils. The results of the soluble sulfate testing are presented below, and are discussed further in a subsequent section of this report.

<u>Sample Identification</u>	<u>Soluble Sulfates (%)</u>	<u>Sulfate Classification</u>
B-3 @ 0 to 5 feet	0.002	Not Applicable (S0)

Corrosivity Testing

One representative sample of the near-surface soils was submitted to a subcontracted corrosion engineering laboratory to identify potentially corrosive characteristics with respect to common construction materials. The corrosivity testing included a determination of the electrical resistivity, pH, and chloride and nitrate concentrations of the soils, as well as other tests. The results of some of these tests are presented below.

<u>Sample Identification</u>	<u>Saturated Resistivity (ohm-cm)</u>	<u>pH</u>	<u>Chlorides (mg/kg)</u>	<u>Nitrates (mg/kg)</u>
B-3 @ 0 to 5 feet	4,000	7.6	4.5	9.4

Grain Size Analysis

Limited grain size analyses have been performed on several selected samples, in accordance with ASTM D-1140. These samples were washed over a #200 sieve to determine the percentage of fine-grained material in each sample, which is defined as the material which passes the #200 sieve. The weight of the portion of the sample retained on each screen is recorded and the percentage finer or coarser of the total weight is calculated. The results of these laboratory tests are shown on the attached Boring Logs.

6.0 CONCLUSIONS AND RECOMMENDATIONS

Based on the results of our review, field exploration, laboratory testing and geotechnical analysis, the proposed development is considered feasible from a geotechnical standpoint. The recommendations contained in this report should be taken into the design, construction, and grading considerations.

The recommendations are contingent upon all grading and foundation construction activities being monitored by the geotechnical engineer of record. The recommendations are provided with the assumption that an adequate program of client consultation, construction monitoring, and testing will be performed during the final design and construction phases to verify compliance with these recommendations. Maintaining Southern California Geotechnical, Inc., (SCG) as the geotechnical consultant from the beginning to the end of the project will provide continuity of services. The geotechnical engineering firm providing testing and observation services shall assume the responsibility of Geotechnical Engineer of Record.

The Grading Guide Specifications, included as Appendix D, should be considered part of this report, and should be incorporated into the project specifications. The contractor and/or owner of the development should bring to the attention of the geotechnical engineer any conditions that differ from those stated in this report, or which may be detrimental for the development.

6.1 Seismic Design Considerations

The subject site is located in an area which is subject to strong ground motions due to earthquakes. The performance of a site-specific seismic hazards analysis was beyond the scope of this investigation. However, numerous faults capable of producing significant ground motions are located near the subject site. Due to economic considerations, it is not generally considered reasonable to design a structure that is not susceptible to earthquake damage. Therefore, significant damage to structures may be unavoidable during large earthquakes. The proposed structures should, however, be designed to resist structural collapse and thereby provide reasonable protection from serious injury, catastrophic property damage and loss of life.

Faulting and Seismicity

Research of available maps indicates that the subject site is not located within an Alquist-Priolo Earthquake Fault Zone. Furthermore, SCG did not identify any evidence of faulting during the geotechnical investigation. Therefore, the possibility of significant fault rupture on the site is considered to be low.

The potential for other geologic hazards such as seismically induced settlement, lateral spreading, tsunamis, inundation, seiches, flooding, and subsidence affecting the site is considered low. Based on Map Number 06065C0745G, dated August 28, 2008, prepared by FEMA Flood Maps, the project site is in an area designated as Zone X which is determined to be outside the 0.2% annual chance floodplain.

Seismic Design Parameters

The 2019 California Building Code (CBC) provides procedures for earthquake resistant structural design that include considerations for on-site soil conditions, occupancy, and the configuration of the structure including the structural system and height. The seismic design parameters presented below are based on the soil profile and the proximity of known faults with respect to the subject site.

Based on standards in place at the time of this report, the proposed development is expected to be designed in accordance with the requirements of the 2019 edition of the California Building Code (CBC), which was adopted on January 1, 2020.

The 2019 CBC Seismic Design Parameters have been generated using the SEAOC/OSHPD Seismic Design Maps Tool, a web-based software application available at the website www.seismicmaps.org. This software application calculates seismic design parameters in accordance with several building code reference documents, including ASCE 7-16, upon which the 2019 CBC is based. The application utilizes a database of risk-targeted maximum considered earthquake (MCE_R) site accelerations at 0.01-degree intervals for each of the code documents. The table below was created using data obtained from the application. The output generated from this program is included as Plate E-1 in Appendix E of this report.

The 2019 CBC requires that a site-specific ground motion study be performed in accordance with Section 11.4.8 of ASCE 7-16 for Site Class D sites with a mapped S_1 value greater than 0.2. However, Section 11.4.8 of ASCE 7-16 also indicates an exception to the requirement for a site-specific ground motion hazard analysis for certain structures on Site Class D sites. The commentary for Section 11 of ASCE 7-16 (Page 534 of Section C11 of ASCE 7-16) indicates that "In general, this exception effectively limits the requirements for site-specific hazard analysis to very tall and or flexible structures at Site Class D sites." **Based on our understanding of the proposed development, the seismic design parameters presented below were calculated assuming that the exception in Section 11.4.8 applies to the proposed structure at this site. However, the structural engineer should verify that this exception is applicable to the proposed structure.** Based on the exception, the spectral response accelerations presented below were calculated using the site coefficients (F_a and F_v) from Tables 1613.2.3(1) and 1613.2.3(2) presented in Section 16.4.4 of the 2019 CBC.

2019 CBC SEISMIC DESIGN PARAMETERS

Parameter		Value
Mapped Spectral Acceleration at 0.2 sec Period	S_S	1.500
Mapped Spectral Acceleration at 1.0 sec Period	S_1	0.600
Site Class	---	D
Site Modified Spectral Acceleration at 0.2 sec Period	S_{MS}	1.500
Site Modified Spectral Acceleration at 1.0 sec Period	S_{M1}	1.020
Design Spectral Acceleration at 0.2 sec Period	S_{DS}	1.000
Design Spectral Acceleration at 1.0 sec Period	S_{D1}	0.680

It should be noted that the site coefficient F_v and the parameters S_{M1} and S_{D1} were not included in the SEAOC/OSHPD Seismic Design Maps Tool output for the ASCE 7-16. We calculated these parameters based on Table 11.4-2 in Section 11.4.4 of ASCE 7-16 using the value of S_1 obtained from the Seismic Design Maps Tool, assuming that a site-specific ground motion hazards analysis is not required for the proposed building at this site.

Ground Motion Parameters

For the purposes of the liquefaction analysis performed for this study, we utilized a site acceleration consistent with maximum considered earthquake ground motions, as required by the 2019 CBC. The peak ground acceleration (PGA) was determined in accordance with Section 11.8.3 of ASCE 7-16. The parameter PGA_M is the maximum considered earthquake geometric mean (MCE_G) PGA, multiplied by the appropriate site coefficient from Table 11.8-1 of ASCE 7-16. The web-based software application SEAOC/OSHPD Seismic Design Maps Tool (described in the previous section) was used to determine PGA_M , which is 0.622g. A portion of the program output is included as Plate E-1 of this report. An associated earthquake magnitude was obtained from the USGS Unified Hazard Tool, Interactive Deaggregation application available on the USGS website. The deaggregated mean magnitude is 6.94, based on the peak ground acceleration and soil classification D.

Liquefaction

The Riverside County GIS website indicates that the site is located in a designated high to moderate liquefaction susceptibility. Therefore, the scope of this investigation included a detailed liquefaction evaluation in order to determine the site-specific liquefaction potential.

Liquefaction is the loss of strength in generally cohesionless, saturated soils when the pore-water pressure induced in the soil by a seismic event becomes equal to or exceeds the overburden pressure. The primary factors which influence the potential for liquefaction include groundwater table elevation, soil type and plasticity characteristics, relative density of the soil, initial confining pressure, and intensity and duration of ground shaking. The depth within which the occurrence of liquefaction may impact surface improvements is generally identified as the upper 50 feet below the existing ground surface. Liquefaction potential is greater in saturated, loose, poorly graded fine sands with a mean (d_{50}) grain size in the range of 0.075 to 0.2 mm (Seed and Idriss, 1971). Non-sensitive clayey (cohesive) soils which possess a plasticity index of at least 18 (Bray and Sancio, 2006) are generally not considered to be susceptible to liquefaction, nor are those soils which are above the historic static groundwater table.

The liquefaction analysis was conducted in accordance with the requirements of Special Publication 117A (CDMG, 2008), and currently accepted practice (SCEC, 1997). The liquefaction potential of the subject site was evaluated using the empirical method developed by Boulanger and Idriss (Boulanger and Idriss, 2008, 2014). This method predicts the earthquake-induced liquefaction potential of the site based on a given design earthquake magnitude and peak ground acceleration at the subject site. This procedure essentially compares the cyclic resistance ratio (CRR) [the cyclic stress ratio required to induce liquefaction for a cohesionless soil stratum at a given depth] with the earthquake-induced cyclic stress ratio (CSR) at that depth from a specified design earthquake (defined by a peak ground surface acceleration and an associated earthquake moment magnitude). CRR is determined as a function of the corrected SPT N-value $(N_1)_{60-cs}$,

adjusted for fines content. The factor of safety against liquefaction is defined as CRR/CSR. Based on Special Publication 117A, a factor of safety of at least 1.3 is required in order to demonstrate that a given soil stratum is non-liquefiable. Additionally, in accordance with Special Publication 117A, clayey soils which do not meet the criteria for liquefiable soils defined by Bray and Sancio (2006), loose soils with a plasticity index (PI) less than 12 and moisture content greater than 85% of the liquid limit, are considered to be unsusceptible to liquefaction. Non-sensitive soils with a PI greater than 18 are also considered non-liquefiable.

The liquefaction analysis procedure is tabulated on the spreadsheet forms included in Appendix F of this report. The liquefaction analysis was performed for Boring Nos. B-1 and B-4, which were advanced to depths of 50± feet. The liquefaction potential was analyzed at the boring locations utilizing a PGA_M of 0.622g related to a 6.94 magnitude seismic event. The liquefaction evaluation was performed using the reported historic high groundwater depth of 14 feet.

If liquefiable soils are identified, the potential settlements that could occur as a result of liquefaction are determined using the equation for volumetric strain due to post-cyclic reconsolidation (Yoshimine et. al, 2006). This procedure uses an empirical relationship between the induced cyclic shear strain and the corrected N-value to determine the expected volumetric strain of saturated sands subjected to earthquake shaking. This analysis is also documented on the spreadsheets included in Appendix F.

Conclusions and Recommendations

The results of the liquefaction analysis identified no potentially liquefiable soils at the site. The soils present below the historic groundwater table possess factors of safety in excess of 1.3 and are therefore considered non-liquefiable. Based on the results of this analysis, no design considerations related to liquefaction are considered warranted for this project.

6.2 Geotechnical Design Considerations

General

Artificial fill soils were encountered beneath the pavements at all of the boring locations, extending to depths of 4½ to 5½± feet below the existing site grades. Based on a lack of documentation regarding the placement and compaction of the existing fill materials, these soils are considered to consist of undocumented fill, and are not suitable for the support of the foundation loads of the proposed structure. Additionally, it is anticipated that demolition of the existing structure and associated improvements will cause disturbance of the upper 4 to 5± feet of soil. However, deeper excavations will be necessary if the existing structure and/or AST's are supported on deep foundations. Therefore, remedial grading will be necessary to remove all of the undocumented fill soils in their entirety, the upper portion of the near-surface native alluvial soils, and any soils disturbed during the demolition process, and replace these materials as compacted structural fill soils.

Settlement

The recommended remedial grading will remove the existing undocumented fill soils and a portion of the near-surface native alluvial soils and replace these materials as compacted structural fill. The native soils that will remain in place below the recommended depth of overexcavation will not be subject to significant stress increases from the foundations of the new structure. Provided that the recommended remedial grading is completed, the post-construction static settlements of the proposed structure are expected to be less than 1.0 and 0.5 inches for total and differential settlements of shallow foundations, respectively.

Expansion

Laboratory testing performed on representative samples of the near-surface soils indicates that these materials possess a low expansion potential ($EI = 21$ and 33). Based on the presence of expansive soils at this site, care should be given to proper moisture conditioning of all building pad subgrade soils to a moisture content of 2 to 4 percent above the ASTM D-1557 optimum during site grading. In addition to adequately moisture conditioning the subgrade soils and fill soils during grading, special care must be taken to maintaining moisture content of these soils at 2 to 4 percent above the optimum moisture content. This will require the contractor to frequently moisture condition these soils throughout the grading process, unless grading occurs during a period of relatively wet weather.

Soluble Sulfates

The result of the soluble sulfate testing indicates that the tested soil sample possesses a level of soluble sulfates that is considered to be "not applicable" (S0) with respect to the American Concrete Institute (ACI) Publication 318-14 Building Code Requirements for Structural Concrete and Commentary, Section 4.3. Therefore, specialized concrete mix designs are not considered to be necessary, with regard to sulfate protection purposes. It is, however, recommended that additional soluble sulfate testing be conducted at the completion of rough grading to verify the soluble sulfate concentrations of the soils which are present at pad grade within the building area.

Corrosion Potential

The results of laboratory testing indicate that the on-site soils possess a saturated resistivity of 4,000 ohm-cm, and a pH value of 7.6. These test results have been evaluated in accordance with guidelines published by the Ductile Iron Pipe Research Association (DIPRA). The DIPRA guidelines consist of a point system by which characteristics of the soils are used to quantify the corrosivity characteristics of the site. Resistivity and pH are two of the five factors that enter into the evaluation procedure. Redox potential, relative soil moisture content and sulfides are also included. Although sulfide testing was not part of the scope of services for this project, we have evaluated the corrosivity characteristics of the on-site soils using resistivity, pH and moisture content. Based on these factors, and utilizing the DIPRA procedure, the on-site soils are not considered to be corrosive to ferrous pipes. Therefore, corrosion protection is not expected to be required for cast iron or ductile iron pipes.

Based on American Concrete Institute (ACI) Publication 318 Building Code Requirements for Structural Concrete and Commentary, reinforced concrete that is exposed to external sources of

chlorides requires corrosion protection for the steel reinforcement contained within the concrete. ACI 318 defines concrete exposed to moisture and an external source of chlorides as "severe" or exposure category C2. ACI 318 does not clearly define a specific chloride concentration at which contact with the adjacent soil will constitute a "C2" or severe exposure. However, the Caltrans Memo to Designers 10-5, Protection of Reinforcement Against Corrosion Due to Chlorides, Acids and Sulfates, dated June 2010, indicates that soils possessing chloride concentrations greater than 500 mg/kg are considered to be corrosive to reinforced concrete. The results of the laboratory testing indicate chloride concentrations of 4.5 mg/kg. Although the soils contain some chlorides, we do not expect that the chloride concentrations of the tested soils are high enough to constitute a "severe" or C2 chloride exposure. Therefore, a chloride exposure category of C1 is considered appropriate for this site.

Nitrates present in soil can be corrosive to copper tubing at concentrations greater than 50 mg/kg. The tested sample possesses a nitrate concentration of 9.4 mg/kg. Based on this test result, the on-site soils are not considered to be corrosive to copper pipe.

Since SCG does not practice in the area of corrosion engineering, we recommend that the client contact a corrosion engineer to provide a more thorough evaluation of these test results.

Shrinkage/Subsidence

Removal and recompaction of the near-surface existing soils is estimated to result in an average shrinkage of 3 to 13 percent. However, shrinkage estimates for the individual samples range between 1 and 16 percent based on the results of density testing and the assumption that the onsite soils will be compacted to about 92 percent of the ASTM D-1557 maximum dry density. It should be noted that the shrinkage estimate is based on the results of dry density testing performed on small-diameter samples of the existing soils taken at the boring locations. If a more accurate and precise shrinkage estimate is desired, SCG can perform a shrinkage study involving several excavated test-pits where in-place densities are determined using in-situ testing methods instead of laboratory density testing on small-diameter samples. Please contact SCG for details and a cost estimate regarding a shrinkage study, if desired.

Minor ground subsidence is expected to occur in the soils below the zone of removal, due to settlement and machinery working. The subsidence is estimated to be 0.15 feet. This estimate may be used for grading in areas that are underlain by native alluvial soils.

These estimates are based on previous experience and the subsurface conditions encountered at the boring locations. The actual amount of subsidence is expected to be variable and will be dependent on the type of machinery used, repetitions of use, and dynamic effects, all of which are difficult to assess precisely.

Grading and Foundation Plan Review

Grading and foundation plans were not available at the time of this report. It is therefore recommended that we be provided with copies of the preliminary grading and foundation plans, when they become available, for review with regard to the conclusions, recommendations, and assumptions contained within this report.

6.3 Site Grading Recommendations

The grading recommendations presented below are based on the subsurface conditions encountered at the boring locations and our understanding of the proposed development. We recommend that all grading activities be completed in accordance with the Grading Guide Specifications included as Appendix D of this report, unless superseded by site-specific recommendations presented below.

Site Stripping and Demolition

Demolition of the existing structure, pavements and any associated improvements will be necessary to facilitate the construction of the proposed development. Demolition of the existing structure should include all foundations, floor slab, and any associated utilities. Any septic systems encountered during demolition and/or grading (if present) should be removed in their entirety. Any associated leach fields or other existing underground improvements should also be removed in their entirety. Debris resultant from demolition should be disposed of off-site. All applicable federal, state and local specifications and regulations should be followed in demolition, abandonment, and disposal of the resulting debris. Alternatively, concrete and asphalt debris may be pulverized to a maximum 2-inch particle size, well mixed with the on-site sands, and incorporated into new structural fills or it may be crushed and made into crushed miscellaneous base (CMB), if desired.

As previously mentioned, a Petromat geotextile material was observed between the AC and base sections at two of the boring locations. The client may wish to contact a demolition contractor to provide a more thorough evaluation of the existing pavements.

Detailed structural information regarding the existing building or AST's have not been provided to our office. Therefore, the foundation systems supporting these structures are generally unknown by SCG. We expect that the existing structures are supported on conventional shallow foundations. However, if the existing structures are supported on deep foundations, any existing piles or drilled piers located within the proposed building area should be cut off at a depth of at least 2 feet below the bottom of the planned overexcavation. Where drilled pier or pile foundations are encountered within proposed pavement areas, they should be cut off at a depth of at least 2 feet below the proposed pavement subgrade or at a depth of at least 1 foot below the bottom of any planned utilities.

Initial site stripping should also include removal of any surficial vegetation from the unpaved areas of the site. This should include any weeds, grasses, shrubs, and trees. Root systems associated with the trees should be removed in their entirety, and the resultant excavations should be backfilled with compacted structural fill soils. The actual extent of site stripping should be determined in the field by the geotechnical engineer, based on the organic content and stability of the materials encountered. These materials should be disposed of off-site.

Treatment of Existing Soils: Building Pad

Remedial grading should be performed within the proposed building area in order to remove the existing undocumented fill soils, any soils disturbed during demolition, and the upper portion of

the near-surface native alluvium. Undocumented fill soils were encountered at most of the boring locations, extending to depths of 4½ to 5½± feet below the existing site grades. Based on conditions encountered at the boring locations, the existing soils within the proposed building area are recommended to be overexcavated to a depth of at least 3 feet below existing grades and to a depth of at least 3 feet below proposed building pad subgrade elevation, whichever is greater. Within the influence zones of the new foundations, the overexcavation should extend to a depth of at least 2 feet below proposed foundation bearing grade.

The overexcavation areas should extend at least 5 feet beyond the building and foundation perimeters, and to an extent equal to the depth of fill placed below the foundation bearing grade, whichever is greater. If the proposed structure incorporates any exterior columns (such as for a canopy or overhang) the area of overexcavation should also encompass these areas.

Following completion of the overexcavation, the subgrade soils within the building area should be evaluated by the geotechnical engineer to verify their suitability to serve as the structural fill subgrade, as well as to support the foundation loads of the new structure. This evaluation should include proofrolling and probing to identify any soft, loose or otherwise unstable soils that must be removed. Some localized areas of deeper excavation may be required if loose, porous, or low-density native soils are encountered at the base of the overexcavation.

After a suitable overexcavation subgrade has been achieved, the exposed soils should be scarified to a depth of at least 12 inches and moisture conditioned or air dried to achieve a moisture content of 2 to 4 percent above optimum moisture content. The subgrade soils should then be recompacted to at least 90 percent of the ASTM D-1557 maximum dry density. The building pad area may then be raised to grade with previously excavated soils or imported structural fill.

Treatment of Existing Soils: Retaining Walls and Site Walls

The existing soils within the areas of any proposed retaining walls and site walls should be overexcavated to a depth of 2 feet below foundation bearing grade and replaced as compacted structural fill as discussed above for the proposed building pad. Any undocumented fill soils or disturbed native alluvium within any of these foundation areas should be removed in their entirety. The overexcavation areas should extend at least 4 feet beyond the foundation perimeters, and to an extent equal to the depth of fill below the new foundations. Any erection pads for tilt-up concrete walls are considered to be part of the foundation system. Therefore, these overexcavation recommendations are applicable to erection pads. The overexcavation subgrade soils should be evaluated by the geotechnical engineer prior to scarifying, moisture conditioning to within 2 to 4 percent above the optimum moisture content, and recompacting the upper 12 inches of exposed subgrade soils. The previously excavated soils may then be replaced as compacted structural fill.

If the full lateral recommended remedial grading cannot be completed for the proposed retaining walls and site walls located along property lines, the foundations for those walls should be designed using a reduced allowable bearing pressure. Furthermore, the contractor should take necessary precautions to protect the adjacent improvements during rough grading. Specialized grading techniques, such as A-B-C slot cuts or temporary shoring, will likely be required during

remedial grading. The geotechnical engineer of record should be contacted if additional recommendations, such as shoring design recommendations, are required during grading.

Treatment of Existing Soils: Flatwork, Parking and Drive Areas

Based on economic considerations, overexcavation of the existing near-surface existing soils in the new parking and drive areas is not considered warranted, with the exception of areas where lower strength or unstable soils are identified by the geotechnical engineer during grading. Subgrade preparation in the new parking and drive areas should initially consist of removal of all soils disturbed during stripping and demolition operations.

The geotechnical engineer should then evaluate the subgrade to identify any areas of additional unsuitable soils. Any such materials should be removed to a level of firm and unyielding soil. The exposed subgrade soils should then be scarified to a depth of 12± inches, moisture conditioned to 2 to 4 percent above the optimum moisture content, and recompacted to at least 90 percent of the ASTM D-1557 maximum dry density. Based on the presence of variable strength surficial soils throughout the site, it is expected that some isolated areas of additional overexcavation may be required to remove zones of lower strength, unsuitable soils.

The grading recommendations presented above for the proposed parking and drive areas assume that the owner and/or developer can tolerate minor amounts of settlement within these areas. The grading recommendations presented above do not mitigate the extent of undocumented fill in the parking and drive areas. As such, some settlement and associated pavement distress could occur. Typically, repair of such distressed areas involves significantly lower costs than completely mitigating these soils at the time of construction. If the owner cannot tolerate the risk of such settlements, the parking and drive areas should be overexcavated to a depth of 2 feet below proposed pavement subgrade elevation, with the resulting soils replaced as compacted structural fill.

Treatment of Existing Soils: Flatwork Areas

Subgrade preparation in the new flatwork areas should initially consist of removal of all soils disturbed during stripping and demolition operations. The geotechnical engineer should then evaluate the subgrade to identify any areas of additional unsuitable soils. The subgrade soils should then be scarified to a depth of 12± inches, moisture conditioned or air dried to 2 to 4 percent above optimum, and recompacted to at least 90 percent of the ASTM D-1557 maximum dry density. Based on the presence of variable strength alluvial soils throughout the subject site, it is expected that some isolated areas of additional overexcavation may be required to remove zones of lower strength, unsuitable soils.

As noted previously, the subject site is underlain by low expansive soils. Support of new flatwork on low expansive soils carries additional risk with respect to flatwork movement and potential distress. This report provides recommendations for moisture conditioning and additional steel reinforcement in the flatwork areas in order to minimize the potential effects of the expansive soils. However, if additional protection is desired, the client should consider the placement of a 2-foot thick layer of non-expansive soil beneath all flatwork.

Fill Placement

- Fill soils should be placed in thin (6± inches), near-horizontal lifts, moisture conditioned (or air dried) to 2 to 4 percent above the optimum moisture content, and compacted.
- On-site soils may be used for fill provided they are cleaned of any debris to the satisfaction of the geotechnical engineer.
- All grading and fill placement activities should be completed in accordance with the requirements of the 2019 CBC and the grading code of the city of Moreno Valley.
- All fill soils should be compacted to at least 90 percent of the ASTM D-1557 maximum dry density. Fill soils should be well mixed.
- Compaction tests should be performed periodically by the geotechnical engineer as random verification of compaction and moisture content. These tests are intended to aid the contractor. Since the tests are taken at discrete locations and depths, they may not be indicative of the entire fill and therefore should not relieve the contractor of his responsibility to meet the job specifications.

Imported Structural Fill

All imported structural fill should consist of very low expansive ($EI < 20$), well graded soils possessing at least 10 percent fines (that portion of the sample passing the No. 200 sieve). Additional specifications for structural fill are presented in the Grading Guide Specifications, included as Appendix D.

Utility Trench Backfill

In general, all utility trench backfill should be compacted to at least 90 percent of the ASTM D-1557 maximum dry density. As an alternative, a clean sand (minimum Sand Equivalent of 30) may be placed within trenches and compacted in place (jetting or flooding is not recommended). It is recommended that materials in excess of 3 inches in size not be used for utility trench backfill. Compacted trench backfill should conform to the requirements of the local grading code, and more restrictive requirements may be indicated by the city of Moreno Valley. All utility trench backfills should be witnessed by the geotechnical engineer. The trench backfill soils should be compaction tested where possible; probed and visually evaluated elsewhere.

Utility trenches which parallel a footing, and extending below a 1h:1v (horizontal to vertical) plane projected from the outside edge of the footing should be backfilled with structural fill soils, compacted to at least 90 percent of the ASTM D-1557 standard. Pea gravel backfill should not be used for these trenches.

Any soils used to backfill voids around subsurface utility structures, such as manholes or vaults, should be placed as compacted structural fill. If it is not practical to place compacted fill in these areas, then such void spaces may be backfilled with lean concrete slurry. Uncompacted pea gravel or sand is not recommended for backfilling these voids since these materials have a potential to settle and thereby cause distress of pavements placed around these subterranean structures.

6.4 Construction Considerations

Excavation Considerations

The near-surface soils generally consist of moderate strength silty sands, sandy silts, silty clays and sandy clays. Some of these materials may be subject to minor to moderate caving within shallow excavations. Where caving does occur, flattened excavation slopes may be sufficient to provide excavation stability. On a preliminary basis, the inclination of temporary slopes should not exceed 2h:1v. In addition, the inclination of temporary slopes should not exceed 1.5h:1v within clayey soils. Deeper excavations may require some form of external stabilization such as shoring or bracing. Maintaining adequate moisture content within the near-surface soils will improve excavation stability. All excavation activities on this site should be conducted in accordance with Cal-OSHA regulations.

Moisture Sensitive Subgrade Soils

Some of the near-surface soils possess appreciable silt and clay content and may become unstable if exposed to significant moisture infiltration or disturbance by construction traffic. In addition, based on their granular content, some of the on-site soils will also be susceptible to erosion. The site should, therefore, be graded to prevent ponding of surface water and to prevent water from running into excavations.

If the construction schedule dictates that site grading will occur during a period of wet weather, allowances should be made for costs and delays associated with drying the on-site soils or import of a drier, less moisture sensitive fill material. Grading during wet or cool weather may also increase the depth of overexcavation in the pad areas as well as the need for a stabilization layer.

Expansive Soils

The near-surface soils within the subject site have been determined to possess a low expansion potential. Therefore, care should be given to proper moisture conditioning of all subgrade soils to a moisture content of 2 to 4 percent above the Modified Proctor optimum during site grading. All imported fill soils should have very low expansive ($EI < 20$) characteristics. **In addition to adequately moisture conditioning the subgrade soils and fill soils during grading, special care must be taken to maintain the moisture content of these soils at 2 to 4 percent above the Modified Proctor optimum. This will require the contractor to frequently moisture condition these soils throughout the grading process, unless grading occurs during a period of relatively wet weather.**

Due to the presence of expansive soils at this site, provisions should be made to limit the potential for surface water to penetrate the soils immediately adjacent to the new structure. These provisions should include directing surface runoff into rain gutters and area drains, reducing the extent of landscaped areas around the structure, and sloping the ground surface away from the building. Where possible, it is recommended that landscaped planters not be located immediately adjacent to the proposed building. If landscaped planters around the building are necessary, it is recommended that drought tolerant plants or a drip irrigation system be utilized, to minimize the

potential for deep moisture penetration around the structure. Presented below is a list of additional soil moisture control recommendations that should be considered by the owner, developer, and civil engineer:

- Ponding and areas of low flow gradients in unpaved walkways, grass and planter areas should be avoided. In general, minimum drainage gradients of 2 percent should be maintained in unpaved areas.
- Bare soil within five feet of proposed structure should be sloped at a minimum five percent gradient away from the structure (about three inches of fall in five feet), or the same area could be paved with a minimum surface gradient of one percent. Pavement is preferable.
- Decorative gravel ground cover tends to provide a reservoir for surface water and may hide areas of ponding or poor drainage. Decorative gravel is, therefore, not recommended and should not be utilized for landscaping unless equipped with a subsurface drainage system designed by a licensed landscape architect.
- Positive drainage devices, such as graded swales, paved ditches, and catch basins should be installed at appropriate locations within the area of proposed development.
- Concrete walks and flatwork should not obstruct the free flow of surface water to the appropriate drainage devices.
- Area drains should be recessed below grade to allow free flow of water into the drain. Concrete or brick flatwork joints should be sealed with mortar or flexible mastic.
- Gutter and downspout systems should be installed to capture all discharge from roof areas. Downspouts should discharge directly into a pipe or paved surface system to be conveyed off-site.
- Enclosed planters adjoining, or in close proximity to the proposed structure, should be sealed at the bottom and provided with subsurface collection systems and outlet pipes.
- Depressed planters should be raised with soil to promote runoff (minimum drainage gradient two percent or five percent, see above), and/or equipped with area drains to eliminate ponding.
- Drainage outfall locations should be selected to avoid erosion of slopes and/or properly armored to prevent erosion of graded surfaces. No drainage should be directed over or towards adjoining slopes.
- All drainage devices should be maintained on a regular basis, including frequent observations during the rainy season to keep the drains free of leaves, soil and other debris.
- Landscape irrigation should conform to the recommendations of the landscape architect and should be performed judiciously to preclude either soaking or excessive drying of the foundation soils. This should entail regular watering during the drier portions of the year and little or no irrigation during the rainy season. Automatic sprinkler systems should, therefore, be switched to manual operation during the rainy season. Good irrigation practice typically requires frequent application of limited quantities of water that are sufficient to sustain plant growth, but do not excessively wet the soils. Ponding and/or run-off of irrigation water are indications of excessive watering.

Other provisions, as determined by the landscape architect or civil engineer, may also be appropriate.

Groundwater

The historic groundwater table at this site is considered to exist at a depth greater than 14± feet. Therefore, groundwater is not expected to impact the grading or foundation construction activities.

6.5 Foundation Design and Construction

Based on the preceding grading recommendations, it is assumed that the new building pad will be underlain by structural fill soils used to replace existing undocumented fill soils and the upper portion of the near-surface native alluvium. These new structural fill soils are expected to extend to depths of at least 2 feet below proposed foundation bearing grade, underlain by 1± foot of additional soil that has been densified and moisture conditioned in place. Based on this subsurface profile, the proposed structure may be supported on conventional shallow foundations.

Foundation Design Parameters

New square and rectangular footings may be designed as follows:

- Maximum, net allowable soil bearing pressure: 2,500 lbs/ft².
- Maximum, net allowable soil bearing pressure: 1,500 lbs/ft² if the full recommended lateral extent of remedial grading cannot be achieved, typically for new footings along the property lines
- Minimum wall/column footing width: 14 inches/24 inches.
- Minimum longitudinal steel reinforcement within strip footings: Four (4) No. 5 rebars (2 top and 2 bottom).
- Minimum foundation embedment: 12 inches into suitable structural fill soils, and at least 18 inches below adjacent exterior grade. Interior column footings may be placed immediately beneath the floor slab.
- It is recommended that the perimeter building foundations be continuous across all exterior doorways. Any flatwork adjacent to the exterior doors should be doweled into the perimeter foundations in a manner determined by the structural engineer.

The allowable bearing pressures presented above may be increased by one-third when considering short duration wind or seismic loads. The minimum steel reinforcement recommended above is based on geotechnical considerations; additional reinforcement may be necessary for structural considerations. The actual design of the foundations should be determined by the structural engineer.

Foundation Construction

The foundation subgrade soils should be evaluated at the time of overexcavation, as discussed in Section 6.3 of this report. It is further recommended that the foundation subgrade soils be evaluated by the geotechnical engineer immediately prior to steel or concrete placement. Soils suitable for direct foundation support should consist of newly placed structural fill, compacted to at least 90 percent of the ASTM D-1557 maximum dry density. Any unsuitable materials should be removed to a depth of suitable bearing compacted structural fill or suitable native alluvium (where reduced bearing pressures are utilized), with the resulting excavations backfilled with

compacted fill soils. As an alternative, lean concrete slurry (500 to 1,500 psi) may be used to backfill such isolated overexcavations.

The foundation subgrade soils should also be properly moisture conditioned to 2 to 4 percent above the Modified Proctor optimum, to a depth of at least 12 inches below bearing grade. Since it is typically not feasible to increase the moisture content of the floor slab and foundation subgrade soils once rough grading has been completed, care should be taken to maintain the moisture content of the building pad subgrade soils throughout the construction process.

Estimated Foundation Settlements

Post-construction total and differential settlements of shallow foundations designed and constructed in accordance with the previously presented recommendations are estimated to be less than 1.0 and 0.5 inches, respectively. Differential movements are expected to occur over a 30-foot span, thereby resulting in an angular distortion of less than 0.002 inches per inch.

Lateral Load Resistance

Lateral load resistance will be developed by a combination of friction acting at the base of foundations and slab and the passive earth pressure developed by footings below grade. The following friction and passive pressure may be used to resist lateral forces:

- Passive Earth Pressure: 275 lbs/ft³
- Friction Coefficient: 0.28

These are allowable values, and include a factor of safety. When combining friction and passive resistance, the passive pressure component should be reduced by one-third. These values assume that footings will be poured directly against compacted structural fill soils. The maximum allowable passive pressure is 2,500 lbs/ft².

6.6 Floor Slab Design and Construction

Subgrades which will support the new floor slab should be prepared in accordance with the recommendations contained in the ***Site Grading Recommendations*** section of this report. Based on the anticipated grading which will occur at this site, the floor of the proposed structure may be constructed as conventional slab-on-grade supported on newly placed structural fill, extending to a depth of at least 3 feet below finished pad grade. Based on geotechnical considerations, the floor slab may be designed as follows:

- Minimum slab thickness: 6 inches.
- Modulus of Subgrade Reaction: 100 psi/in.
- Minimum slab reinforcement: No. 3 bars at 18-inches on-center, in both directions, due to presence of low expansive soils. The actual floor slab reinforcement should be determined by the structural engineer, based upon the imposed loading.

- Slab underlayment: If moisture sensitive floor coverings will be used then minimum slab underlayment should consist of a moisture vapor barrier constructed below the entire slab area where such moisture sensitive floor coverings are expected. The moisture vapor barrier should meet or exceed the Class A rating as defined by ASTM E 1745-97 and have a permeance rating less than 0.01 perms as described in ASTM E 96-95 and ASTM E 154-88. A polyolefin material such as 15 mil Stego® Wrap Vapor Barrier or equivalent will meet these specifications. The moisture vapor barrier should be properly constructed in accordance with all applicable manufacturer specifications. Given that a rock free subgrade is anticipated and that a capillary break is not required, sand below the barrier is not required. The need for sand and/or the amount of sand above the moisture vapor barrier should be specified by the structural engineer or concrete contractor. The selection of sand above the barrier is not a geotechnical engineering issue and hence outside our purview. Where moisture sensitive floor coverings are not anticipated, the vapor barrier may be eliminated.
- Moisture condition the floor slab subgrade soils to 2 to 4 percent above the Modified Proctor optimum moisture content, to a depth of 12 inches. The moisture content of the floor slab subgrade soils should be verified by the geotechnical engineer within 24 hours prior to concrete placement.
- Proper concrete curing techniques should be utilized to reduce the potential for slab curling or the formation of excessive shrinkage cracks.
- The floor slab should be structurally connected to the foundations as detailed by the structural engineer.

The actual design of the floor slab should be completed by the structural engineer to verify adequate thickness and reinforcement.

6.7 Exterior Flatwork Design and Construction

Subgrades which will support new exterior slabs-on-grade for sidewalks, patios, and other concrete flatwork, should be prepared in accordance with the recommendations contained in the ***Grading Recommendations*** section of this report. Based on geotechnical considerations, exterior slabs on grade may be designed as follows:

- Minimum slab thickness: 4½ inches.
- Minimum slab reinforcement: No. 3 bars at 18 inches on center, in both directions.
- The flatwork at building entry areas should be structurally connected to the perimeter foundation that is recommended to span across the door opening. This recommendation is designed to reduce the potential for differential movement at this joint.
- Moisture condition the slab subgrade soils to at least 2 to 4 percent of optimum moisture content, to a depth of at least 12 inches. Adequate moisture conditioning should be verified by the geotechnical engineer 24 hours prior to concrete placement.

- Proper concrete curing techniques should be utilized to reduce the potential for slab curling or the formation of excessive shrinkage cracks.
- Control joints should be provided at a maximum spacing of 8 feet on center in two directions for slabs and at 6 feet on center for sidewalks. Control joints are intended to direct cracking. Minor cracking of exterior concrete slabs on grade should be expected.

Expansion or felt joints should be used at the interface of exterior slabs on grade and any fixed structures to permit relative movement.

6.8 Retaining Wall Design and Construction

Based on the conceptual grading plan, retaining walls greater than 6 feet in height will be required to facilitate the new site grades. Retaining walls are also expected within the truck dock area of the proposed building. The parameters recommended for use in the design of these walls are presented below.

Retaining Wall Design Parameters

Based on the soil conditions encountered at the boring locations, the following parameters may be used in the design of new retaining walls for this site. The following parameters assume that only the on-site soils will be utilized for retaining wall backfill. The near-surface soils generally consist of silty sands and clayey sands, with occasional silty clays, sandy clays and clayey silts. Based on the results of laboratory testing, the on-site silty sands and clayey sands possess a friction angle of 30 degrees when compacted to at least 90 percent of the ASTM D-1557 maximum dry density. It is recommended that clays and clayey silts be excluded from use as retaining wall backfill.

If desired, SCG could provide design parameters for an alternative select backfill material behind the retaining walls. The use of select backfill material could result in lower lateral earth pressures. In order to use the design parameters for the imported select fill, this material must be placed within the entire active failure wedge. This wedge is defined as extending from the heel of the retaining wall upwards at an angle of approximately 60° from horizontal. If select backfill material behind the retaining wall is desired, SCG should be contacted for supplementary recommendations.

RETAINING WALL DESIGN PARAMETERS

Design Parameter		Soil Type
		On-Site Silty Sands and Clayey Sands
Internal Friction Angle (ϕ)		30°
Unit Weight		132 lbs/ft ³
Equivalent Fluid Pressure:	Active Condition (level backfill)	44 lbs/ft ³
	Active Condition (2h:1v backfill)	71 lbs/ft ³
	At-Rest Condition (level backfill)	66 lbs/ft ³

The walls should be designed using a soil-footing coefficient of friction of 0.28 and an equivalent passive pressure of 275 lbs/ft³. The structural engineer should incorporate appropriate factors of safety in the design of the retaining walls.

The active earth pressure may be used for the design of retaining walls that do not directly support structures or support soils that in turn support structures and which will be allowed to deflect. The at-rest earth pressure should be used for walls that will not be allowed to deflect such as those which will support foundation bearing soils, or which will support foundation loads directly.

Where the soils on the toe side of the retaining wall are not covered by a "hard" surface such as a structure or pavement, the upper 1 foot of soil should be neglected when calculating passive resistance due to the potential for the material to become disturbed or degraded during the life of the structure.

Retaining Wall Foundation Design

The retaining wall foundations should be underlain by at least 2 feet of newly placed structural fill. Foundations to support new retaining walls should be designed in accordance with the general Foundation Design Parameters presented in a previous section of this report.

Seismic Lateral Earth Pressures

In accordance with the 2019 CBC, any retaining walls more than 6 feet in height must be designed for seismic lateral earth pressures. If walls 6 feet or more are required for this site, the geotechnical engineer should be contacted for supplementary seismic lateral earth pressure recommendations.

Backfill Material

On-site soils may be used to backfill the retaining walls, provided that they are very low expansive (EI < 20) sandy soils. All backfill material placed within 3 feet of the back wall-face should have a particle size no greater than 3 inches. The retaining wall backfill materials should be well graded.

It is recommended that a minimum 1-foot thick layer of free-draining granular material (less than 5 percent passing the No. 200 sieve) be placed against the face of the retaining walls. This material should extend from the top of the retaining wall footing to within 1 foot of the ground surface on the back side of the retaining wall. This material should be approved by the geotechnical engineer. In lieu of the 1-foot thick layer of free-draining material, a properly installed prefabricated drainage composite such as the MiraDRAIN 6000XL (or approved equivalent), which is specifically designed for use behind retaining walls, may be used. If the layer of free-draining material is not covered by an impermeable surface, such as a structure or pavement, a 12-inch thick layer of a low permeability soil should be placed over the backfill to reduce surface water migration to the underlying soils. The layer of free draining granular material should be separated from the backfill soils by a suitable geotextile, approved by the geotechnical engineer.

All retaining wall backfill should be placed and compacted under engineering controlled conditions in the necessary layer thicknesses to ensure an in-place density between 90 and 93 percent of the maximum dry density as determined by the Modified Proctor test (ASTM D1557). Care should be taken to avoid over-compaction of the soils behind the retaining walls, and the use of heavy compaction equipment should be avoided.

Subsurface Drainage

As previously indicated, the retaining wall design parameters are based upon drained backfill conditions. Consequently, some form of permanent drainage system will be necessary in conjunction with the appropriate backfill material. Subsurface drainage may consist of either:

- A weep hole drainage system typically consisting of a series of 2-inch diameter holes in the wall situated slightly above the ground surface elevation on the exposed side of the wall and at an approximate 10-foot on-center spacing. Alternatively, 4-inch diameter holes at an approximate 20-foot on-center spacing can be used for this type of drainage system. In addition, the weep holes should include a 2 cubic foot pocket of open graded gravel, surrounded by an approved geotextile fabric, at each weep hole location.
- A 4-inch diameter perforated pipe surrounded by 2 cubic feet of gravel per linear foot of drain placed behind the wall, above the retaining wall footing. The gravel layer should be wrapped in a suitable geotextile fabric to reduce the potential for migration of fines. The footing drain should be extended to daylight or tied into a storm drainage system. The actual design of this type of system should be determined by the civil engineer to verify that the drainage system possesses the adequate capacity and slope for its intended use.

Weep holes or a footing drain will not be required for building stem walls.

6.9 Pavement Design Parameters

Site preparation in the pavement area should be completed as previously recommended in the ***Site Grading Recommendations*** section of this report. The subsequent pavement recommendations assume proper drainage and construction monitoring, and are based on either PCA or CALTRANS design parameters for a twenty (20) year design period. However, these

designs also assume a routine pavement maintenance program to obtain the anticipated 20-year pavement service life.

Pavement Subgrades

It is anticipated that the new pavements will be primarily supported on a layer of compacted structural fill, consisting of scarified, thoroughly moisture conditioned and recompacted existing soils. The near surface soils generally consist of silty sands and clayey sands, with occasional silty clays, sandy clays, and clayey silts. These soils are generally considered to possess fair pavement support characteristics with estimated R-values of 30 to 40. R-value testing was outside the scope of services. The subsequent pavement design is therefore based upon an assumed R-value of 30. Any fill material imported to the site should have support characteristics equal to or greater than that of the on-site soils and be placed and compacted under engineering controlled conditions. It is recommended that R-value testing be performed after completion of rough grading. Depending upon the results of the R-value testing, it may be feasible to use thinner pavement sections in some areas of the site.

Asphaltic Concrete

Presented below are the recommended thicknesses for new flexible pavement structures consisting of asphaltic concrete over a granular base. The pavement designs are based on the traffic indices (TI's) indicated. The client and/or civil engineer should verify that these TI's are representative of the anticipated traffic volumes. If the client and/or civil engineer determine that the expected traffic volume will exceed the applicable traffic index, we should be contacted for supplementary recommendations. The design traffic indices equate to the following approximate daily traffic volumes over a 20-year design life, assuming six operational traffic days per week.

Traffic Index	No. of Heavy Trucks per Day
4.0	0
5.0	1
6.0	3
7.0	11
8.0	35
9.0	93

For the purpose of the traffic volumes indicated above, a truck is defined as a 5-axle tractor trailer unit with one 8-kip axle and two 32-kip tandem axles. All of the traffic indices allow for 1,000 automobiles per day.

ASPHALT PAVEMENTS (R = 30)					
Materials	Thickness (inches)				
	Auto Parking and Auto Drive Lanes (TI = 4.0 to 5.0)	Truck Traffic			
		TI = 6.0	TI = 7.0	TI = 8.0	TI = 9.0
Asphalt Concrete	3	3½	4	5	5½
Aggregate Base	6	8	10	11	13
Compacted Subgrade	12	12	12	12	12

The aggregate base course should be compacted to at least 95 percent of the ASTM D-1557 maximum dry density. The asphaltic concrete should be compacted to at least 95 percent of the batch plant-reported maximum density. The aggregate base course may consist of crushed aggregate base (CAB) or crushed miscellaneous base (CMB), which is a recycled gravel, asphalt and concrete material. The gradation, R-Value, Sand Equivalent, and Percentage Wear of the CAB or CMB should comply with appropriate specifications contained in the current edition of the "Greenbook" Standard Specifications for Public Works Construction.

Portland Cement Concrete

The preparation of the subgrade soils within concrete pavement areas should be performed as previously described for proposed asphalt pavement areas. The minimum recommended thicknesses for the Portland Cement Concrete pavement sections are as follows:

PORTLAND CEMENT CONCRETE PAVEMENTS (R = 30)				
Materials	Thickness (inches)			
	Autos and Light Truck Traffic (TI = 6.0)	Truck Traffic		
		(TI =7.0)	(TI =8.0)	(TI =9.0)
PCC	5	5½	6½	8
Compacted Subgrade (95% minimum compaction)	12	12	12	12

The concrete should have a 28-day compressive strength of at least 3,000 psi. Any reinforcement within the PCC pavements should be determined by the project structural engineer. The maximum joint spacing within all of the PCC pavements is recommended to be equal to or less than 30 times the pavement thickness.

7.0 GENERAL COMMENTS

This report has been prepared as an instrument of service for use by the client, in order to aid in the evaluation of this property and to assist the architects and engineers in the design and preparation of the project plans and specifications. This report may be provided to the contractor(s) and other design consultants to disclose information relative to the project. However, this report is not intended to be utilized as a specification in and of itself, without appropriate interpretation by the project architect, civil engineer, and/or structural engineer. The reproduction and distribution of this report must be authorized by the client and Southern California Geotechnical, Inc. Furthermore, any reliance on this report by an unauthorized third party is at such party's sole risk, and we accept no responsibility for damage or loss which may occur. The client(s)' reliance upon this report is subject to the Engineering Services Agreement, incorporated into our proposal for this project.

The analysis of this site was based on a subsurface profile interpolated from limited discrete soil samples. While the materials encountered in the project area are considered to be representative of the total area, some variations should be expected between boring locations and sample depths. If the conditions encountered during construction vary significantly from those detailed herein, we should be contacted immediately to determine if the conditions alter the recommendations contained herein.

This report has been based on assumed or provided characteristics of the proposed development. It is recommended that the owner, client, architect, structural engineer, and civil engineer carefully review these assumptions to ensure that they are consistent with the characteristics of the proposed development. If discrepancies exist, they should be brought to our attention to verify that they do not affect the conclusions and recommendations contained herein. We also recommend that the project plans and specifications be submitted to our office for review to verify that our recommendations have been correctly interpreted.

The analysis, conclusions, and recommendations contained within this report have been promulgated in accordance with generally accepted professional geotechnical engineering practice. No other warranty is implied or expressed.

8.0 REFERENCES

California Division of Mines and Geology (CDMG), "Guidelines for Evaluating and Mitigating Seismic Hazards in California," State of California, Department of Conservation, Division of Mines and Geology, Special Publication 117A, 2008.

Idriss, I. M. and Boulanger, R. W., "Soil Liquefaction During Earthquakes," Earthquake Engineering Research Institute, 2008.

Idriss, I. M. and Boulanger, R. W., "SPT-Based Liquefaction Triggering Procedures," Earthquake Engineering Research Institute, 2010.

Boulanger, R. W. and Idriss, I. M., "CPT and SPT Based Liquefaction Triggering Procedures," Earthquake Engineering Research Institute, 2014.

National Research Council (NRC), "Liquefaction of Soils During Earthquakes," Committee on Earthquake Engineering, National Research Council, Washington D. C., Report No. CETS-EE-001, 1985.

Seed, H. B., and Idriss, I. M., "Simplified Procedure for Evaluating Soil Liquefaction Potential using field Performance Data," Journal of the Soil Mechanics and Foundations Division, American Society of Civil Engineers, September 1971, pp. 1249-1273.

Southern California Earthquake Center (SCEC), University of Southern California, "Recommended Procedures for Implementation of DMG Special Publication 117, Guidelines for Analyzing and Mitigating Liquefaction in California," Committee formed 1997.

Tokimatsu K., and Seed, H. B., "Evaluation of Settlements in Sands Due to Earthquake Shaking," Journal of the Geotechnical Engineering Division, American society of Civil Engineers, Volume 113, No. 8, August 1987, pp. 861-878.

Tokimatsu, K. and Yoshimi, Y., "*Empirical Correlations of Soil Liquefaction Based on SPT N-value and Fines Content*," Seismological Research Letters, Eastern Section Seismological Society Of America, Volume 63, Number 1, p. 73.

Youd, T. L. and Idriss, I. M. (Editors), "Proceedings of the NCEER Workshop on Evaluation of Liquefaction Resistance of Soils," Salt Lake City, UT, January 5-6 1996, NCEER Technical Report NCEER-97-0022, Buffalo, NY.

APPENDIX A

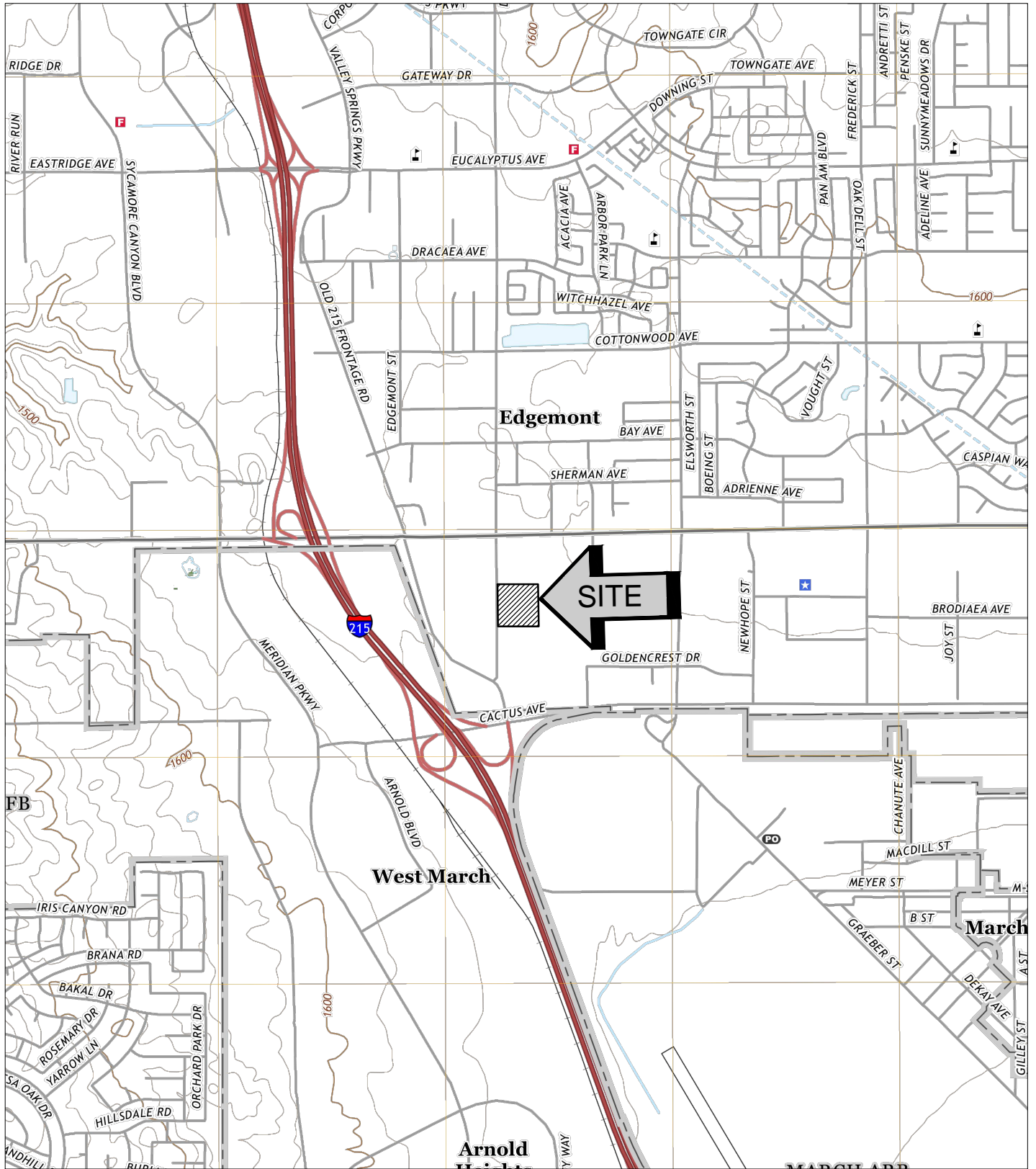

SOURCE: USGS TOPOGRAPHIC MAP OF THE RIVERSIDE EAST QUADRANGLE, RIVERSIDE COUNTY, CALIFORNIA, 2018.



SITE LOCATION MAP	
PROPOSED WAREHOUSE	
MORENO VALLEY, CALIFORNIA	
SCALE: 1" = 2000'	 SOUTHERN CALIFORNIA GEOTECHNICAL
DRAWN: JLL	
CHKD: RGT	
SCG PROJECT 21G291-1	
PLATE 1	

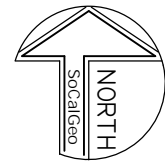
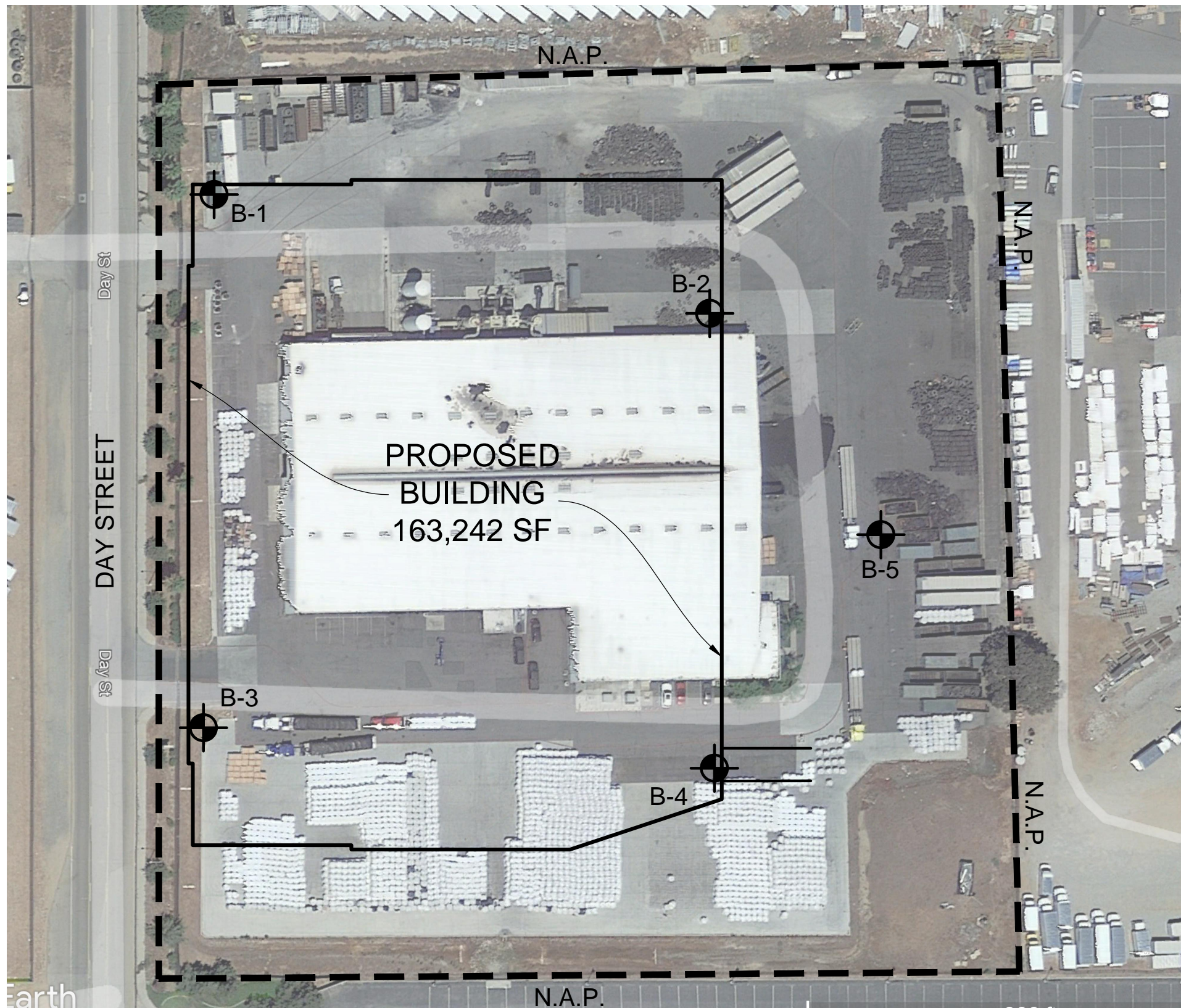

GEOTECHNICAL LEGEND







 APPROXIMATE BORING LOCATION

NOTE: PRELIMINARY SITE PLAN PREPARED BY RGA.
AERIAL PHOTOGRAPH OBTAINED FROM GOOGLE EARTH.

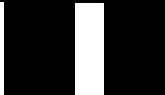
BORING LOCATION PLAN	
PROPOSED WAREHOUSE	
MORENO VALLEY, CALIFORNIA	
SCALE: 1" = 80'	 SOUTHERN CALIFORNIA GEOTECHNICAL
DRAWN: JLL	
CHKD: RGT	
SCG PROJECT 21G291-1	
PLATE 2	

APPENDIX B

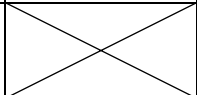
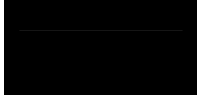
BORING LOG LEGEND

SAMPLE TYPE	GRAPHICAL SYMBOL	SAMPLE DESCRIPTION
AUGER		SAMPLE COLLECTED FROM AUGER CUTTINGS, NO FIELD MEASUREMENT OF SOIL STRENGTH. (DISTURBED)
CORE		ROCK CORE SAMPLE: TYPICALLY TAKEN WITH A DIAMOND-TIPPED CORE BARREL. TYPICALLY USED ONLY IN HIGHLY CONSOLIDATED BEDROCK.
GRAB		SOIL SAMPLE TAKEN WITH NO SPECIALIZED EQUIPMENT, SUCH AS FROM A STOCKPILE OR THE GROUND SURFACE. (DISTURBED)
CS		CALIFORNIA SAMPLER: 2-1/2 INCH I.D. SPLIT BARREL SAMPLER, LINED WITH 1-INCH HIGH BRASS RINGS. DRIVEN WITH SPT HAMMER. (RELATIVELY UNDISTURBED)
NSR		NO RECOVERY: THE SAMPLING ATTEMPT DID NOT RESULT IN RECOVERY OF ANY SIGNIFICANT SOIL OR ROCK MATERIAL.
SPT		STANDARD PENETRATION TEST: SAMPLER IS A 1.4 INCH INSIDE DIAMETER SPLIT BARREL, DRIVEN 18 INCHES WITH THE SPT HAMMER. (DISTURBED)
SH		SHELBY TUBE: TAKEN WITH A THIN WALL SAMPLE TUBE, PUSHED INTO THE SOIL AND THEN EXTRACTED. (UNDISTURBED)
VANE		VANE SHEAR TEST: SOIL STRENGTH OBTAINED USING A 4 BLADED SHEAR DEVICE. TYPICALLY USED IN SOFT CLAYS-NO SAMPLE RECOVERED.

COLUMN DESCRIPTIONS

DEPTH:

Distance in feet below the ground surface.

SAMPLE:

Sample Type as depicted above.

BLOW COUNT:

Number of blows required to advance the sampler 12 inches using a 140 lb hammer with a 30-inch drop. 50/3" indicates penetration refusal (>50 blows) at 3 inches. WH indicates that the weight of the hammer was sufficient to push the sampler 6 inches or more.

POCKET PEN.:

Approximate shear strength of a cohesive soil sample as measured by pocket penetrometer.

GRAPHIC LOG:

Graphic Soil Symbol as depicted on the following page.

DRY DENSITY:

Dry density of an undisturbed or relatively undisturbed sample in lbs/ft³.

MOISTURE CONTENT:

Moisture content of a soil sample, expressed as a percentage of the dry weight.

LIQUID LIMIT:

The moisture content above which a soil behaves as a liquid.

PLASTIC LIMIT:

The moisture content above which a soil behaves as a plastic.

PASSING #200 SIEVE:

The percentage of the sample finer than the #200 standard sieve.

UNCONFINED SHEAR:

The shear strength of a cohesive soil sample, as measured in the unconfined state.

SOIL CLASSIFICATION CHART

MAJOR DIVISIONS			SYMBOLS		TYPICAL DESCRIPTIONS	
			GRAPH	LETTER		
<p>COARSE GRAINED SOILS</p> <p>MORE THAN 50% OF MATERIAL IS LARGER THAN NO. 200 SIEVE SIZE</p>	<p>GRAVEL AND GRAVELLY SOILS</p>	<p>CLEAN GRAVELS</p> <p>(LITTLE OR NO FINES)</p>		GW	WELL-GRADED GRAVELS, GRAVEL - SAND MIXTURES, LITTLE OR NO FINES	
		<p>MORE THAN 50% OF COARSE FRACTION RETAINED ON NO. 4 SIEVE</p>	<p>GRAVELS WITH FINES</p> <p>(APPRECIABLE AMOUNT OF FINES)</p>		GP	POORLY-GRADED GRAVELS, GRAVEL - SAND MIXTURES, LITTLE OR NO FINES
			<p>GRAVELS WITH FINES</p> <p>(APPRECIABLE AMOUNT OF FINES)</p>		GM	SILTY GRAVELS, GRAVEL - SAND - SILT MIXTURES
		<p>MORE THAN 50% OF COARSE FRACTION PASSING ON NO. 4 SIEVE</p>	<p>CLEAN SANDS</p> <p>(LITTLE OR NO FINES)</p>		SW	WELL-GRADED SANDS, GRAVELLY SANDS, LITTLE OR NO FINES
	<p>MORE THAN 50% OF COARSE FRACTION PASSING ON NO. 4 SIEVE</p>		<p>SANDS WITH FINES</p> <p>(APPRECIABLE AMOUNT OF FINES)</p>		SP	POORLY-GRADED SANDS, GRAVELLY SAND, LITTLE OR NO FINES
		<p>SANDS WITH FINES</p> <p>(APPRECIABLE AMOUNT OF FINES)</p>		SM	SILTY SANDS, SAND - SILT MIXTURES	
	<p>SANDS WITH FINES</p> <p>(APPRECIABLE AMOUNT OF FINES)</p>		SC	CLAYEY SANDS, SAND - CLAY MIXTURES		
	<p>FINE GRAINED SOILS</p> <p>MORE THAN 50% OF MATERIAL IS SMALLER THAN NO. 200 SIEVE SIZE</p>	<p>SILTS AND CLAYS</p> <p>LIQUID LIMIT LESS THAN 50</p>		ML	INORGANIC SILTS AND VERY FINE SANDS, ROCK FLOUR, SILTY OR CLAYEY FINE SANDS OR CLAYEY SILTS WITH SLIGHT PLASTICITY	
				CL	INORGANIC CLAYS OF LOW TO MEDIUM PLASTICITY, GRAVELLY CLAYS, SANDY CLAYS, SILTY CLAYS, LEAN CLAYS	
				OL	ORGANIC SILTS AND ORGANIC SILTY CLAYS OF LOW PLASTICITY	
<p>SILTS AND CLAYS</p> <p>LIQUID LIMIT GREATER THAN 50</p>			MH	INORGANIC SILTS, MICACEOUS OR DIATOMACEOUS FINE SAND OR SILTY SOILS		
			CH	INORGANIC CLAYS OF HIGH PLASTICITY		
			OH	ORGANIC CLAYS OF MEDIUM TO HIGH PLASTICITY, ORGANIC SILTS		
<p>HIGHLY ORGANIC SOILS</p>				PT	PEAT, HUMUS, SWAMP SOILS WITH HIGH ORGANIC CONTENTS	

NOTE: DUAL SYMBOLS ARE USED TO INDICATE BORDERLINE SOIL CLASSIFICATIONS



JOB NO.: 21G291-1	DRILLING DATE: 1/5/22	WATER DEPTH: 21.5 feet
PROJECT: Proposed Warehouse	DRILLING METHOD: Hollow Stem Auger	CAVE DEPTH: 18 feet
LOCATION: Moreno Valley, California	LOGGED BY: Daryl Kas	READING TAKEN: 3 Hrs After Completion

FIELD RESULTS				GRAPHIC LOG	DESCRIPTION	LABORATORY RESULTS						COMMENTS
DEPTH (FEET)	SAMPLE	BLOW COUNT	POCKET PEN. (TSF)			DRY DENSITY (PCF)	MOISTURE CONTENT (%)	LIQUID LIMIT	PLASTIC LIMIT	PASSING #200 SIEVE (%)	ORGANIC CONTENT (%)	
SURFACE ELEVATION: --- MSL												
				[Concrete Symbol]	CONCRETE: 7± inches Portland Cement Concrete, no discernible Aggregate Base							
				[Fill Symbol]	FILL: Brown Silty fine Sand, little medium Sand, trace Clay, medium dense to dense-moist to very moist		11					
				[Alluvium Symbol]	ALLUVIUM: Gray Brown Silty Clay to Clayey Silt, trace to little fine Sand, very stiff-very moist		13					
			4.5	[Clay Symbol]	Brown Silty Clay, trace to little fine Sand, stiff-very moist		21					
			3.0	[Clay Symbol]	Brown Silty Clay, trace to little fine Sand, stiff-very moist		24					
				[Clay Symbol]	Brown Clayey fine Sand to fine Sandy Clay, trace to little Silt, medium dense to very stiff-damp to moist		11		41			
			4.5	[Clay Symbol]								
			3.0	[Clay Symbol]			13		40			
				[Clay Symbol]	Red Brown Clayey fine to medium Sand, little Silt, dense-wet		12		36			
			3.0	[Clay Symbol]								
			36	[Clay Symbol]	@ 30', trace Coarse Sand		15		24			

TBL 21G291-1.GPJ_SOCALGEO.GDT 2/14/22



JOB NO.: 21G291-1	DRILLING DATE: 1/5/22	WATER DEPTH: 21.5 feet
PROJECT: Proposed Warehouse	DRILLING METHOD: Hollow Stem Auger	CAVE DEPTH: 18 feet
LOCATION: Moreno Valley, California	LOGGED BY: Daryl Kas	READING TAKEN: 3 Hrs After Completion

FIELD RESULTS				GRAPHIC LOG	DESCRIPTION (Continued)	LABORATORY RESULTS						COMMENTS
DEPTH (FEET)	SAMPLE	BLOW COUNT	POCKET PEN. (TSF)			DRY DENSITY (PCF)	MOISTURE CONTENT (%)	LIQUID LIMIT	PLASTIC LIMIT	PASSING #200 SIEVE (%)	ORGANIC CONTENT (%)	
					Red Brown Clayey fine to medium Sand, little Silt, trace coarse Sand, dense-wet							
35		54			Brown fine to coarse Sand, little Silt, very dense-wet		12			10		
					Brown Silty fine to coarse Sand, dense-wet							
40		47			Brown Clayey fine to medium Sand, trace coarse Sand, trace Silt, dense-wet		14			17		
					Brown Silty fine Sand, trace Clay, dense-wet							
45		35			Gray Brown Clayey fine Sand, little Silt, dense-wet		16 15			30 32		
					Brown Silty fine Sand, trace to little medium Sand, trace Clay, dense-wet							
50		49					15			34		
					Boring Terminated at 50'							

TBL 21G291-1.GPJ_SOCALGEO.GDT 2/14/22



JOB NO.: 21G291-1	DRILLING DATE: 1/6/22	WATER DEPTH: Dry
PROJECT: Proposed Warehouse	DRILLING METHOD: Hollow Stem Auger	CAVE DEPTH: 19 feet
LOCATION: Moreno Valley, California	LOGGED BY: Daryl Kas	READING TAKEN: At Completion

FIELD RESULTS				GRAPHIC LOG	DESCRIPTION	LABORATORY RESULTS						COMMENTS
DEPTH (FEET)	SAMPLE	BLOW COUNT	POCKET PEN. (TSF)			DRY DENSITY (PCF)	MOISTURE CONTENT (%)	LIQUID LIMIT	PLASTIC LIMIT	PASSING #200 SIEVE (%)	ORGANIC CONTENT (%)	
SURFACE ELEVATION: --- MSL												
					3± inches Asphaltic Concrete, 5± inches Aggregate Base							
	X	14			FILL: Brown Clayey fine to medium Sand, trace coarse Sand, trace Silt, loose to medium dense-moist	103	11					
	X	33			FILL: Brown Silty fine Sand, trace medium to coarse Sand, trace Clay, medium dense-moist	112	12					
5	X	34			ALLUVIUM: Gray Brown Silty fine to medium Sand, trace Clay, medium dense-moist to very moist	118	12					
	X	29			Brown Silty fine Sand, little medium Sand, trace Clay, medium dense-moist to very moist	119	14					
10	X	25			Brown Silty fine to medium Sand, little coarse Sand, trace Clay, medium dense-moist to very moist	117	12					
	X	11	3.0		Gray Brown Silty Clay to Clayey Silt, little fine Sand, stiff-very moist		21					
15	X				Brown fine to medium Sandy Clay, little Silt, stiff-very moist							
	X	11	2.5		Gray Brown Silty Clay, little fine Sand, very stiff-very moist		34					
20	X				Gray Brown Silty Clay, little fine Sand, very stiff-very moist							
	X	15	3.0		Boring Terminated at 25'		18					
25	X											

TBL_21G291-1.GPJ_SOCALGEO.GDT_2/14/22



JOB NO.: 21G291-1	DRILLING DATE: 1/6/22	WATER DEPTH: Dry
PROJECT: Proposed Warehouse	DRILLING METHOD: Hollow Stem Auger	CAVE DEPTH: 17 feet
LOCATION: Moreno Valley, California	LOGGED BY: Daryl Kas	READING TAKEN: At Completion

FIELD RESULTS				GRAPHIC LOG	DESCRIPTION	LABORATORY RESULTS						COMMENTS
DEPTH (FEET)	SAMPLE	BLOW COUNT	POCKET PEN. (TSF)			DRY DENSITY (PCF)	MOISTURE CONTENT (%)	LIQUID LIMIT	PLASTIC LIMIT	PASSING #200 SIEVE (%)	ORGANIC CONTENT (%)	
SURFACE ELEVATION: --- MSL												
					3± inches Asphaltic Concrete, 4± inches Aggregate Base							
	X	10			FILL: Brown Silty fine to medium Sand, trace medium Sand, little Clay, loose-moist	120	10					EI = 33 @ 0 to 5 feet
	X	16			FILL: Brown Silty fine Sand, trace medium Sand, trace to little Clay, medium dense-moist to very moist	116	12					
5	X	35			ALLUVIUM: Gray Brown Clayey fine to medium Sand, little Silt, medium dense-damp to moist	116	11					
	X	41			Brown fine to coarse Sand, trace to little Clay, trace Silt, medium dense-very moist	114	9					
10	X	66			Red Brown Silty fine to medium Sand, little coarse Sand, little Clay, dense-very moist	111	23					
	X	32			Red Brown Clayey fine to medium Sand, trace Silt, medium dense-very moist	105	17					
	X	29			Gray Brown Silty fine Sand, little medium to coarse Sand, little Clay, medium dense-moist to very moist	123	11					
20					Boring Terminated at 20'							

TBL_21G291-1.GPJ_SOCALGEO.GDT 2/14/22



JOB NO.: 21G291-1 DRILLING DATE: 1/5/22 WATER DEPTH: 23 feet
 PROJECT: Proposed Warehouse DRILLING METHOD: Hollow Stem Auger CAVE DEPTH: 24 feet
 LOCATION: Moreno Valley, California LOGGED BY: Daryl Kas READING TAKEN: 3 Hrs After Completion

FIELD RESULTS				GRAPHIC LOG	DESCRIPTION	LABORATORY RESULTS						COMMENTS
DEPTH (FEET)	SAMPLE	BLOW COUNT	POCKET PEN. (TSF)			DRY DENSITY (PCF)	MOISTURE CONTENT (%)	LIQUID LIMIT	PLASTIC LIMIT	PASSING #200 SIEVE (%)	ORGANIC CONTENT (%)	
SURFACE ELEVATION: --- MSL												
					3± inches Asphaltic Concrete, 5± inches Aggregate Base							
		7			FILL: Brown Clayey fine to medium Sand, little Silt, mottled, loose-very moist		16					EI = 21 @ 0 to 5 feet
		9			FILL: Brown Silty fine to medium Sand, trace to little coarse Sand, trace Clay, loose-very moist		14					
5			4.0		ALLUVIUM: Brown fine Sandy Clay, little medium Sand, little Silt, stiff-moist				13			
		11										
		29			Light Brown fine Sandy Silt, trace medium Sand, little Clay, medium dense-very moist		24					
10												
		42			Brown Clayey fine to medium Sand, little Silt, dense-moist		12		42			
15												
		19	3.5		Gray Brown fine Sandy Clay, little Silt, very stiff-very moist		27		61			
20												
		30			Gray Brown Silty fine Sand, little medium Sand, trace Clay, dense-wet		13		38			
25												
		28	4.0		Gray Brown Clayey fine Sand to fine Sandy Clay, little medium Sand, trace Silt, medium dense to very stiff-wet		16		46			
					Brown Silty fine Sand, trace medium Sand, medium dense-wet		15		37			

TBL 21G291-1.GPJ_SOCALGEO.GDT 2/14/22



JOB NO.: 21G291-1	DRILLING DATE: 1/5/22	WATER DEPTH: 23 feet
PROJECT: Proposed Warehouse	DRILLING METHOD: Hollow Stem Auger	CAVE DEPTH: 24 feet
LOCATION: Moreno Valley, California	LOGGED BY: Daryl Kas	READING TAKEN: 3 Hrs After Completion

FIELD RESULTS				GRAPHIC LOG	DESCRIPTION	LABORATORY RESULTS						COMMENTS
DEPTH (FEET)	SAMPLE	BLOW COUNT	POCKET PEN. (TSF)			DRY DENSITY (PCF)	MOISTURE CONTENT (%)	LIQUID LIMIT	PLASTIC LIMIT	PASSING #200 SIEVE (%)	ORGANIC CONTENT (%)	
(Continued)					Brown Silty fine Sand, trace medium Sand, medium dense-wet							
35		37			Red Brown Silty fine to medium Sand, dense-wet		13			31		
40		41			Brown fine to coarse Sand, trace Silt, very dense-wet		13			33		
45		44					17			34		
50		50					15			6		
50					Boring Terminated at 50'							

TBL 21G291-1.GPJ_SOCALGEO.GDT 2/14/22



JOB NO.: 21G291-1	DRILLING DATE: 1/6/22	WATER DEPTH: Dry
PROJECT: Proposed Warehouse	DRILLING METHOD: Hollow Stem Auger	CAVE DEPTH: 15 feet
LOCATION: Moreno Valley, California	LOGGED BY: Daryl Kas	READING TAKEN: At Completion

FIELD RESULTS				GRAPHIC LOG	DESCRIPTION	LABORATORY RESULTS						COMMENTS
DEPTH (FEET)	SAMPLE	BLOW COUNT	POCKET PEN. (TSF)			DRY DENSITY (PCF)	MOISTURE CONTENT (%)	LIQUID LIMIT	PLASTIC LIMIT	PASSING #200 SIEVE (%)	ORGANIC CONTENT (%)	
SURFACE ELEVATION: --- MSL												
					1± inches Asphaltic Concrete, 4± inches Aggregate Base							
		15			FILL: Gray Brown Clayey fine to medium Sand, trace to little Silt, slightly mottled, medium dense-moist to very moist		13					
		18			FILL: Gray Brown Silty fine Sand, trace Portland cement concrete fragments, medium dense-damp to moist		7					
5												
		35			ALLUVIUM: Red Brown Silty fine Sand, trace medium Sand, trace Clay, dense-moist		11					
		32			Brown Silty fine to medium Sand, trace to little coarse Sand, dense-moist		8					
10												
		15	2.5		Gray Brown Silty Clay, trace to little fine Sand, stiff to very stiff-very moist		32					
15												
		21			Gray Brown fine Sandy Silt, trace to little Clay, medium dense-very moist		21					
20												
Boring Terminated at 20'												

TBL_21G291-1.GPJ_SOCALGEO.GDT 2/14/22

A P P E N D I X C

Consolidation/Collapse Test Results

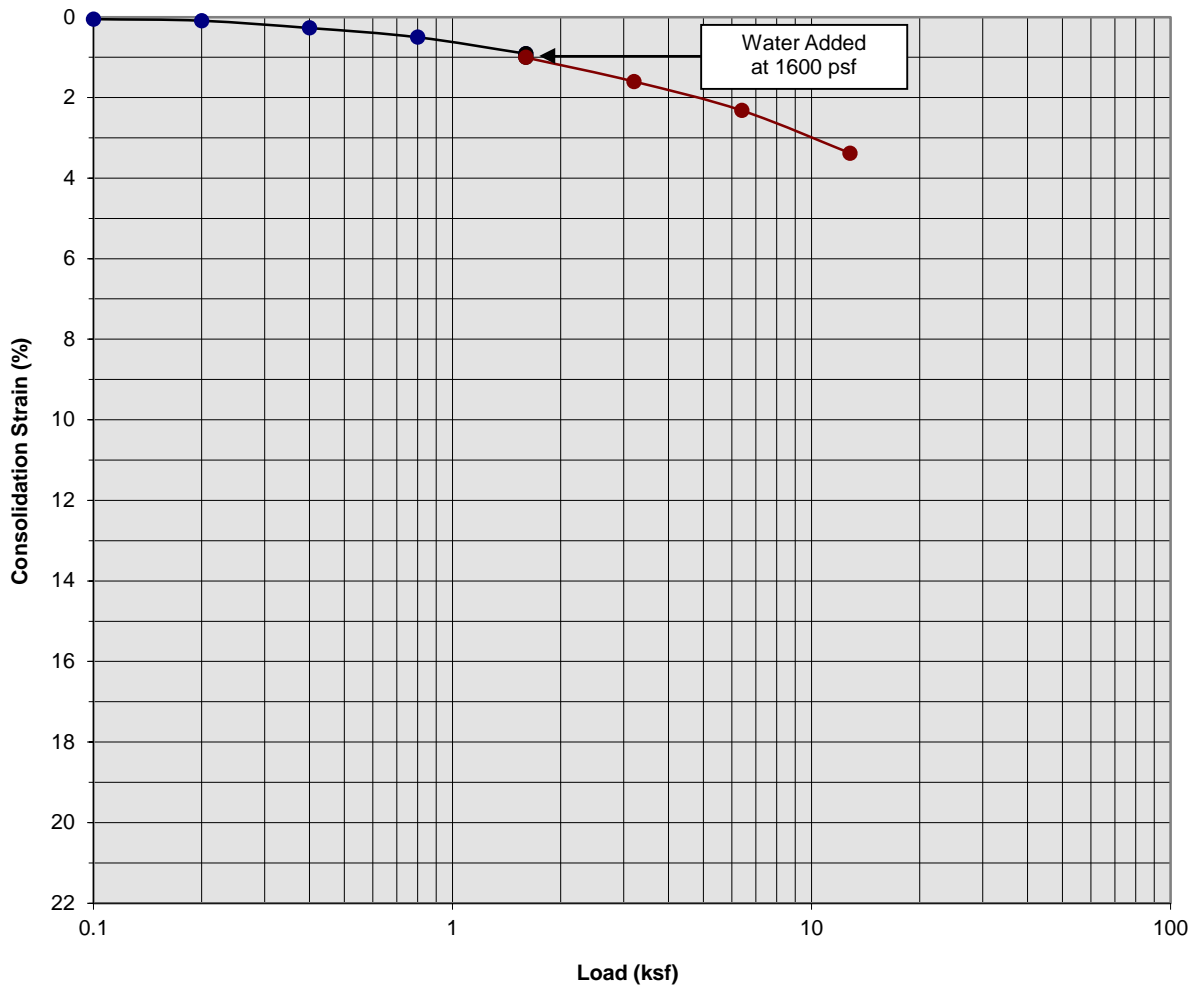

Classification: FILL: Brown Silty fine to medium Sand, trace coarse Sand, little Clay

Boring Number:	B-3	Initial Moisture Content (%)	10
Sample Number:	---	Final Moisture Content (%)	15
Depth (ft)	1 to 2	Initial Dry Density (pcf)	120.3
Specimen Diameter (in)	2.4	Final Dry Density (pcf)	124.0
Specimen Thickness (in)	1.0	Percent Collapse (%)	0.09

Proposed Warehouse
 Moreno Valley, California
 Project No. 21G291-1
PLATE C- 1



**SOUTHERN
 CALIFORNIA
 GEOTECHNICAL**
A California Corporation

Consolidation/Collapse Test Results

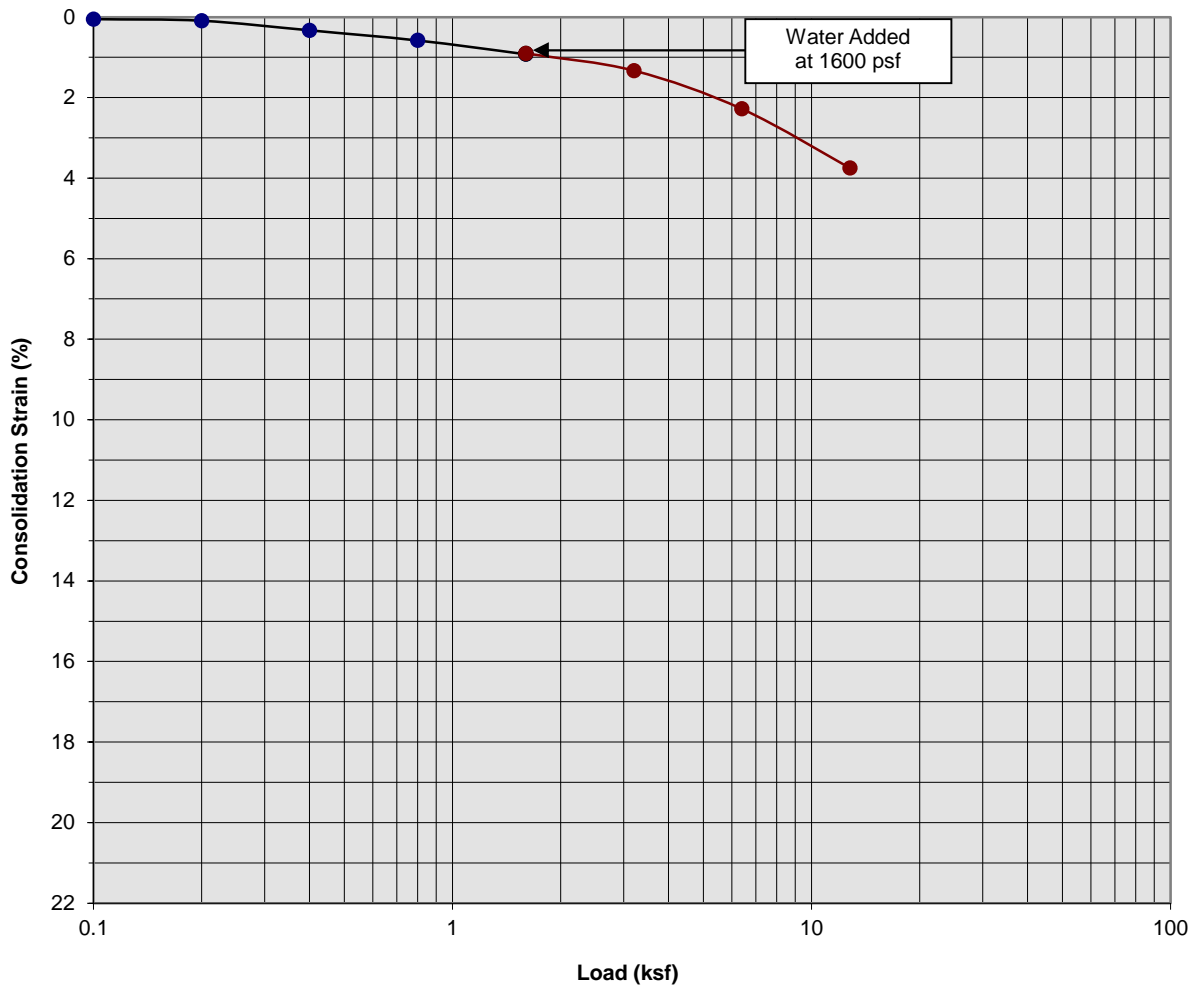

Classification: FILL: Brown Silty fine Sand, trace medium Sand, trace to little Clay

Boring Number:	B-3	Initial Moisture Content (%)	12
Sample Number:	---	Final Moisture Content (%)	15
Depth (ft)	3 to 4	Initial Dry Density (pcf)	116.4
Specimen Diameter (in)	2.4	Final Dry Density (pcf)	120.5
Specimen Thickness (in)	1.0	Percent Collapse (%)	-0.02

Proposed Warehouse
 Moreno Valley, California
 Project No. 21G291-1
PLATE C- 2



SOUTHERN CALIFORNIA GEOTECHNICAL
A California Corporation

Consolidation/Collapse Test Results

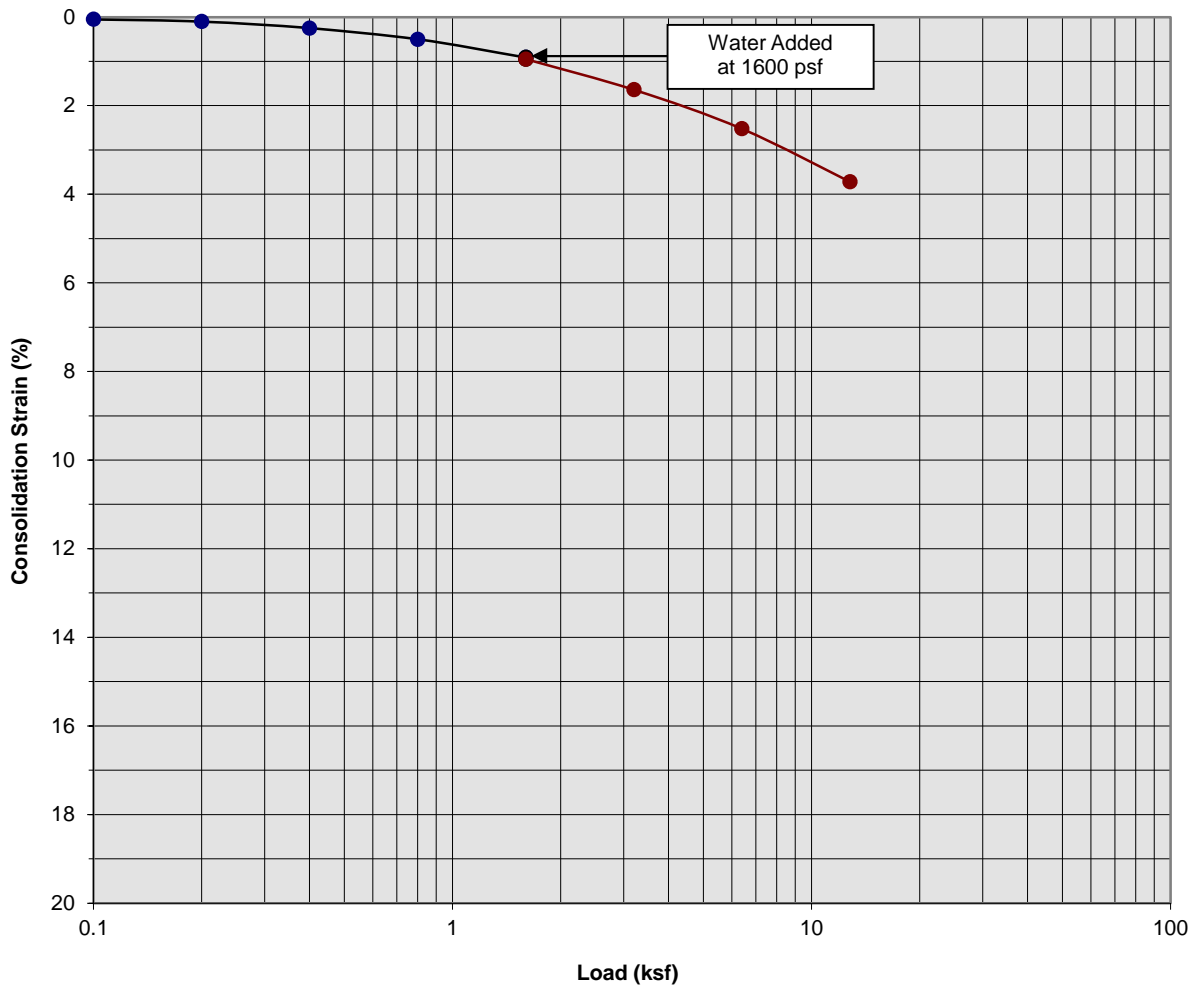

Classification: Gray Brown Clayey fine to medium Sand, little Silt

Boring Number:	B-3	Initial Moisture Content (%)	11
Sample Number:	---	Final Moisture Content (%)	18
Depth (ft)	5 to 6	Initial Dry Density (pcf)	116.1
Specimen Diameter (in)	2.4	Final Dry Density (pcf)	119.6
Specimen Thickness (in)	1.0	Percent Collapse (%)	0.04

Proposed Warehouse
 Moreno Valley, California
 Project No. 21G291-1
PLATE C- 3



**SOUTHERN
 CALIFORNIA
 GEOTECHNICAL**
A California Corporation

Consolidation/Collapse Test Results

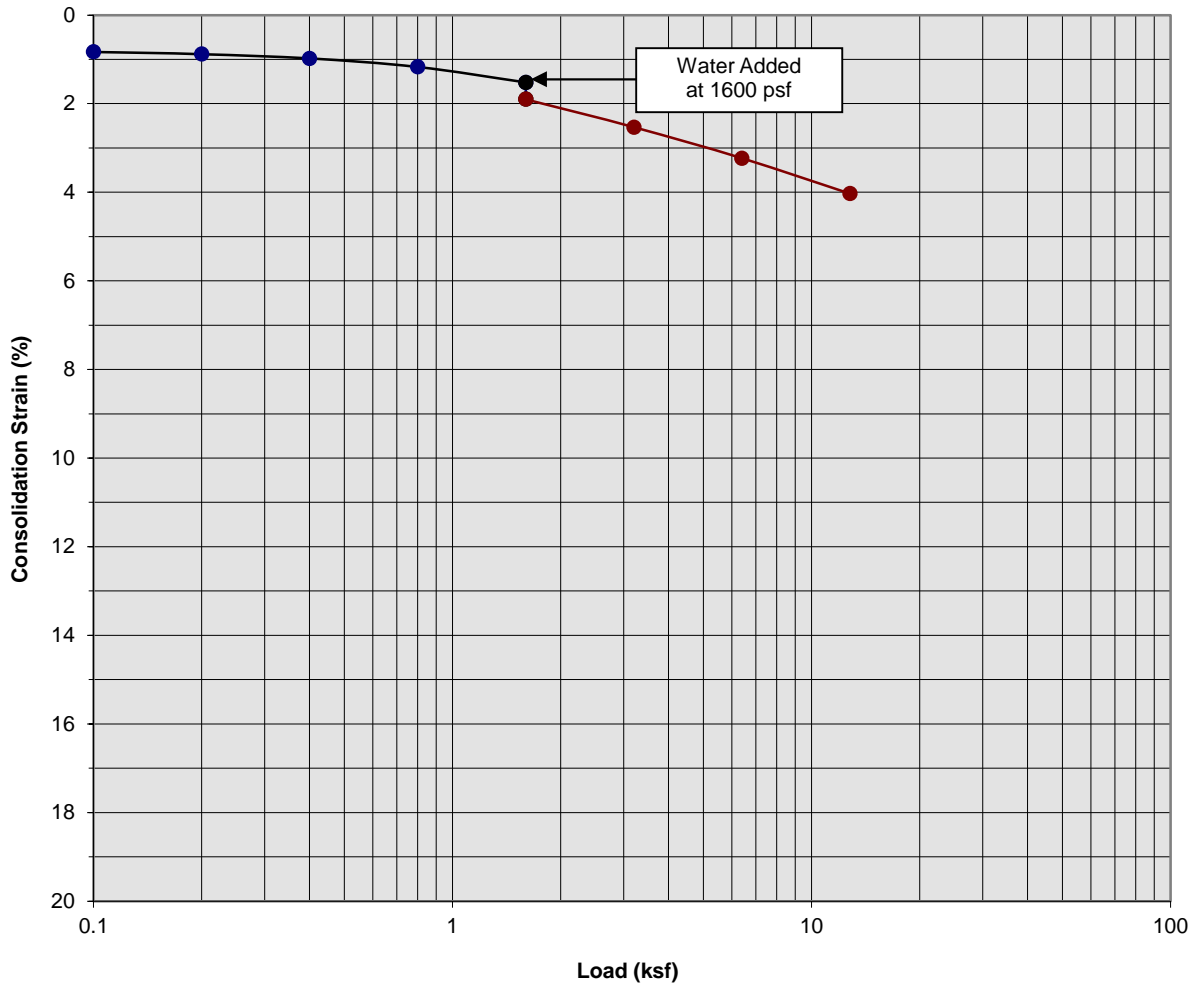

Classification: Brown fine to coarse Sand, trace to little Clay, trace Silt

Boring Number:	B-3	Initial Moisture Content (%)	9
Sample Number:	---	Final Moisture Content (%)	12
Depth (ft)	7 to 8	Initial Dry Density (pcf)	113.8
Specimen Diameter (in)	2.4	Final Dry Density (pcf)	120.4
Specimen Thickness (in)	1.0	Percent Collapse (%)	0.38

Proposed Warehouse
 Moreno Valley, California
 Project No. 21G291-1
PLATE C- 4



**SOUTHERN
 CALIFORNIA
 GEOTECHNICAL**
A California Corporation

Moisture/Density Relationship ASTM D-1557

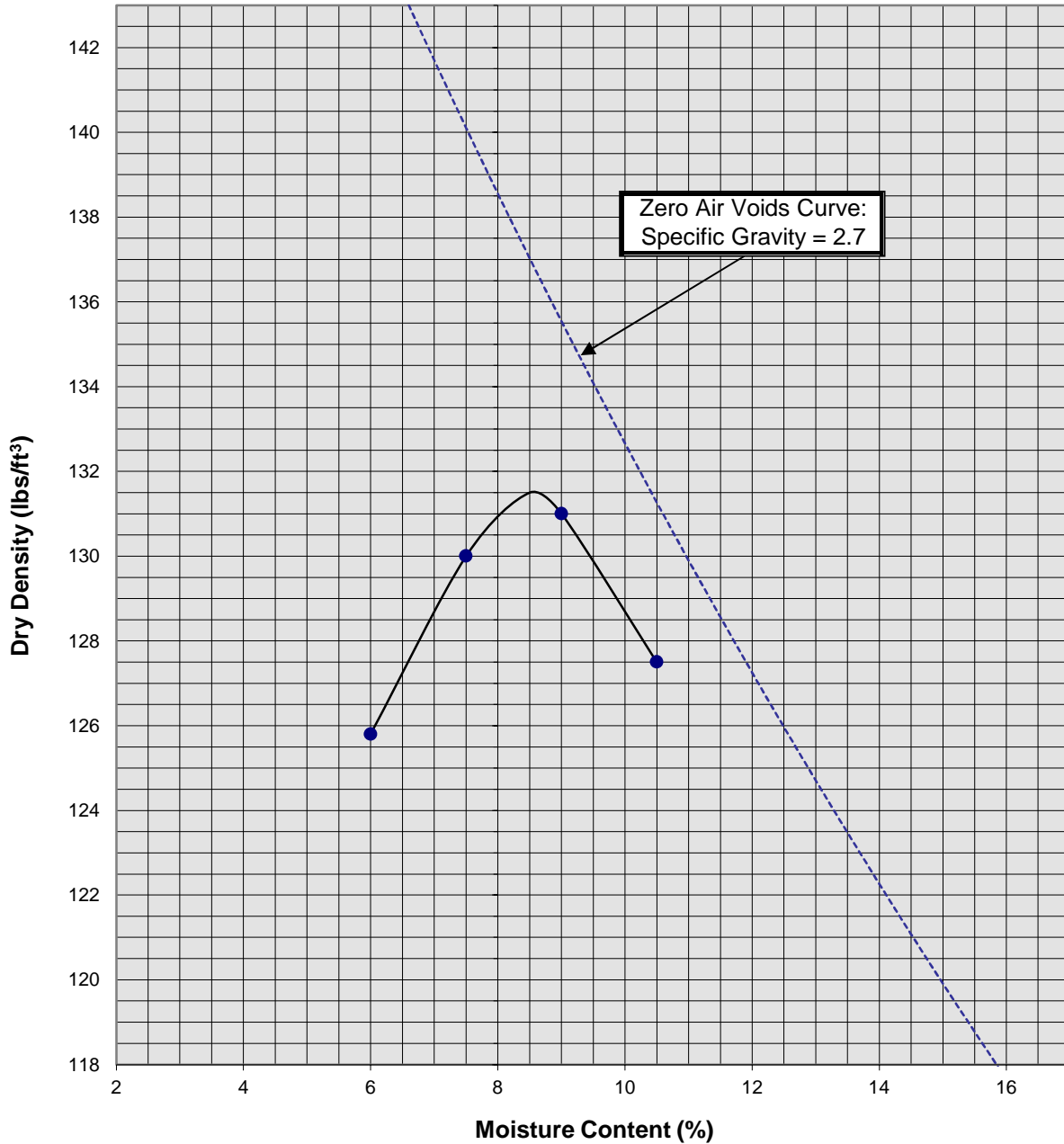

Soil ID Number	B-3 @ 0-5'
Optimum Moisture (%)	8.5
Maximum Dry Density (pcf)	131.5
Soil Classification	Brown Silty fine to medium Sand, little coarse Sand, little Clay

Proposed Warehouse
Moreno Valley, California
Project No. 21G291-1

PLATE C-5



SOUTHERN CALIFORNIA GEOTECHNICAL
A California Corporation

APPENDIX

GRADING GUIDE SPECIFICATIONS

These grading guide specifications are intended to provide typical procedures for grading operations. They are intended to supplement the recommendations contained in the geotechnical investigation report for this project. Should the recommendations in the geotechnical investigation report conflict with the grading guide specifications, the more site specific recommendations in the geotechnical investigation report will govern.

General

- The Earthwork Contractor is responsible for the satisfactory completion of all earthwork in accordance with the plans and geotechnical reports, and in accordance with city, county, and applicable building codes.
- The Geotechnical Engineer is the representative of the Owner/Builder for the purpose of implementing the report recommendations and guidelines. These duties are not intended to relieve the Earthwork Contractor of any responsibility to perform in a workman-like manner, nor is the Geotechnical Engineer to direct the grading equipment or personnel employed by the Contractor.
- The Earthwork Contractor is required to notify the Geotechnical Engineer of the anticipated work and schedule so that testing and inspections can be provided. If necessary, work may be stopped and redone if personnel have not been scheduled in advance.
- The Earthwork Contractor is required to have suitable and sufficient equipment on the job-site to process, moisture condition, mix and compact the amount of fill being placed to the approved compaction. In addition, suitable support equipment should be available to conform with recommendations and guidelines in this report.
- Canyon cleanouts, overexcavation areas, processed ground to receive fill, key excavations, subdrains and benches should be observed by the Geotechnical Engineer prior to placement of any fill. It is the Earthwork Contractor's responsibility to notify the Geotechnical Engineer of areas that are ready for inspection.
- Excavation, filling, and subgrade preparation should be performed in a manner and sequence that will provide drainage at all times and proper control of erosion. Precipitation, springs, and seepage water encountered shall be pumped or drained to provide a suitable working surface. The Geotechnical Engineer must be informed of springs or water seepage encountered during grading or foundation construction for possible revision to the recommended construction procedures and/or installation of subdrains.

Site Preparation

- The Earthwork Contractor is responsible for all clearing, grubbing, stripping and site preparation for the project in accordance with the recommendations of the Geotechnical Engineer.
- If any materials or areas are encountered by the Earthwork Contractor which are suspected of having toxic or environmentally sensitive contamination, the Geotechnical Engineer and Owner/Builder should be notified immediately.

- Major vegetation should be stripped and disposed of off-site. This includes trees, brush, heavy grasses and any materials considered unsuitable by the Geotechnical Engineer.
- Underground structures such as basements, cesspools or septic disposal systems, mining shafts, tunnels, wells and pipelines should be removed under the inspection of the Geotechnical Engineer and recommendations provided by the Geotechnical Engineer and/or city, county or state agencies. If such structures are known or found, the Geotechnical Engineer should be notified as soon as possible so that recommendations can be formulated.
- Any topsoil, slopewash, colluvium, alluvium and rock materials which are considered unsuitable by the Geotechnical Engineer should be removed prior to fill placement.
- Remaining voids created during site clearing caused by removal of trees, foundations basements, irrigation facilities, etc., should be excavated and filled with compacted fill.
- Subsequent to clearing and removals, areas to receive fill should be scarified to a depth of 10 to 12 inches, moisture conditioned and compacted
- The moisture condition of the processed ground should be at or slightly above the optimum moisture content as determined by the Geotechnical Engineer. Depending upon field conditions, this may require air drying or watering together with mixing and/or discing.

Compacted Fills

- Soil materials imported to or excavated on the property may be utilized in the fill, provided each material has been determined to be suitable in the opinion of the Geotechnical Engineer. Unless otherwise approved by the Geotechnical Engineer, all fill materials shall be free of deleterious, organic, or frozen matter, shall contain no chemicals that may result in the material being classified as "contaminated," and shall be very low to non-expansive with a maximum expansion index (EI) of 50. The top 12 inches of the compacted fill should have a maximum particle size of 3 inches, and all underlying compacted fill material a maximum 6-inch particle size, except as noted below.
- All soils should be evaluated and tested by the Geotechnical Engineer. Materials with high expansion potential, low strength, poor gradation or containing organic materials may require removal from the site or selective placement and/or mixing to the satisfaction of the Geotechnical Engineer.
- Rock fragments or rocks less than 6 inches in their largest dimensions, or as otherwise determined by the Geotechnical Engineer, may be used in compacted fill, provided the distribution and placement is satisfactory in the opinion of the Geotechnical Engineer.
- Rock fragments or rocks greater than 12 inches should be taken off-site or placed in accordance with recommendations and in areas designated as suitable by the Geotechnical Engineer. These materials should be placed in accordance with Plate D-8 of these Grading Guide Specifications and in accordance with the following recommendations:
 - Rocks 12 inches or more in diameter should be placed in rows at least 15 feet apart, 15 feet from the edge of the fill, and 10 feet or more below subgrade. Spaces should be left between each rock fragment to provide for placement and compaction of soil around the fragments.
 - Fill materials consisting of soil meeting the minimum moisture content requirements and free of oversize material should be placed between and over the rows of rock or

concrete. Ample water and compactive effort should be applied to the fill materials as they are placed in order that all of the voids between each of the fragments are filled and compacted to the specified density.

- Subsequent rows of rocks should be placed such that they are not directly above a row placed in the previous lift of fill. A minimum 5-foot offset between rows is recommended.
- To facilitate future trenching, oversized material should not be placed within the range of foundation excavations, future utilities or other underground construction unless specifically approved by the soil engineer and the developer/owner representative.
- Fill materials approved by the Geotechnical Engineer should be placed in areas previously prepared to receive fill and in evenly placed, near horizontal layers at about 6 to 8 inches in loose thickness, or as otherwise determined by the Geotechnical Engineer for the project.
- Each layer should be moisture conditioned to optimum moisture content, or slightly above, as directed by the Geotechnical Engineer. After proper mixing and/or drying, to evenly distribute the moisture, the layers should be compacted to at least 90 percent of the maximum dry density in compliance with ASTM D-1557-78 unless otherwise indicated.
- Density and moisture content testing should be performed by the Geotechnical Engineer at random intervals and locations as determined by the Geotechnical Engineer. These tests are intended as an aid to the Earthwork Contractor, so he can evaluate his workmanship, equipment effectiveness and site conditions. The Earthwork Contractor is responsible for compaction as required by the Geotechnical Report(s) and governmental agencies.
- Fill areas unused for a period of time may require moisture conditioning, processing and recompaction prior to the start of additional filling. The Earthwork Contractor should notify the Geotechnical Engineer of his intent so that an evaluation can be made.
- Fill placed on ground sloping at a 5-to-1 inclination (horizontal-to-vertical) or steeper should be benched into bedrock or other suitable materials, as directed by the Geotechnical Engineer. Typical details of benching are illustrated on Plates D-2, D-4, and D-5.
- Cut/fill transition lots should have the cut portion overexcavated to a depth of at least 3 feet and rebuilt with fill (see Plate D-1), as determined by the Geotechnical Engineer.
- All cut lots should be inspected by the Geotechnical Engineer for fracturing and other bedrock conditions. If necessary, the pads should be overexcavated to a depth of 3 feet and rebuilt with a uniform, more cohesive soil type to impede moisture penetration.
- Cut portions of pad areas above buttresses or stabilizations should be overexcavated to a depth of 3 feet and rebuilt with uniform, more cohesive compacted fill to impede moisture penetration.
- Non-structural fill adjacent to structural fill should typically be placed in unison to provide lateral support. Backfill along walls must be placed and compacted with care to ensure that excessive unbalanced lateral pressures do not develop. The type of fill material placed adjacent to below grade walls must be properly tested and approved by the Geotechnical Engineer with consideration of the lateral earth pressure used in the design.

Foundations

- The foundation influence zone is defined as extending one foot horizontally from the outside edge of a footing, and proceeding downward at a ½ horizontal to 1 vertical (0.5:1) inclination.
- Where overexcavation beneath a footing subgrade is necessary, it should be conducted so as to encompass the entire foundation influence zone, as described above.
- Compacted fill adjacent to exterior footings should extend at least 12 inches above foundation bearing grade. Compacted fill within the interior of structures should extend to the floor subgrade elevation.

Fill Slopes

- The placement and compaction of fill described above applies to all fill slopes. Slope compaction should be accomplished by overfilling the slope, adequately compacting the fill in even layers, including the overfilled zone and cutting the slope back to expose the compacted core
- Slope compaction may also be achieved by backrolling the slope adequately every 2 to 4 vertical feet during the filling process as well as requiring the earth moving and compaction equipment to work close to the top of the slope. Upon completion of slope construction, the slope face should be compacted with a sheepsfoot connected to a sideboom and then grid rolled. This method of slope compaction should only be used if approved by the Geotechnical Engineer.
- Sandy soils lacking in adequate cohesion may be unstable for a finished slope condition and therefore should not be placed within 15 horizontal feet of the slope face.
- All fill slopes should be keyed into bedrock or other suitable material. Fill keys should be at least 15 feet wide and inclined at 2 percent into the slope. For slopes higher than 30 feet, the fill key width should be equal to one-half the height of the slope (see Plate D-5).
- All fill keys should be cleared of loose slough material prior to geotechnical inspection and should be approved by the Geotechnical Engineer and governmental agencies prior to filling.
- The cut portion of fill over cut slopes should be made first and inspected by the Geotechnical Engineer for possible stabilization requirements. The fill portion should be adequately keyed through all surficial soils and into bedrock or suitable material. Soils should be removed from the transition zone between the cut and fill portions (see Plate D-2).

Cut Slopes

- All cut slopes should be inspected by the Geotechnical Engineer to determine the need for stabilization. The Earthwork Contractor should notify the Geotechnical Engineer when slope cutting is in progress at intervals of 10 vertical feet. Failure to notify may result in a delay in recommendations.
- Cut slopes exposing loose, cohesionless sands should be reported to the Geotechnical Engineer for possible stabilization recommendations.
- All stabilization excavations should be cleared of loose slough material prior to geotechnical inspection. Stakes should be provided by the Civil Engineer to verify the location and dimensions of the key. A typical stabilization fill detail is shown on Plate D-5.

- Stabilization key excavations should be provided with subdrains. Typical subdrain details are shown on Plates D-6.

Subdrains

- Subdrains may be required in canyons and swales where fill placement is proposed. Typical subdrain details for canyons are shown on Plate D-3. Subdrains should be installed after approval of removals and before filling, as determined by the Soils Engineer.
- Plastic pipe may be used for subdrains provided it is Schedule 40 or SDR 35 or equivalent. Pipe should be protected against breakage, typically by placement in a square-cut (backhoe) trench or as recommended by the manufacturer.
- Filter material for subdrains should conform to CALTRANS Specification 68-1.025 or as approved by the Geotechnical Engineer for the specific site conditions. Clean $\frac{3}{4}$ -inch crushed rock may be used provided it is wrapped in an acceptable filter cloth and approved by the Geotechnical Engineer. Pipe diameters should be 6 inches for runs up to 500 feet and 8 inches for the downstream continuations of longer runs. Four-inch diameter pipe may be used in buttress and stabilization fills.

CUT LOT

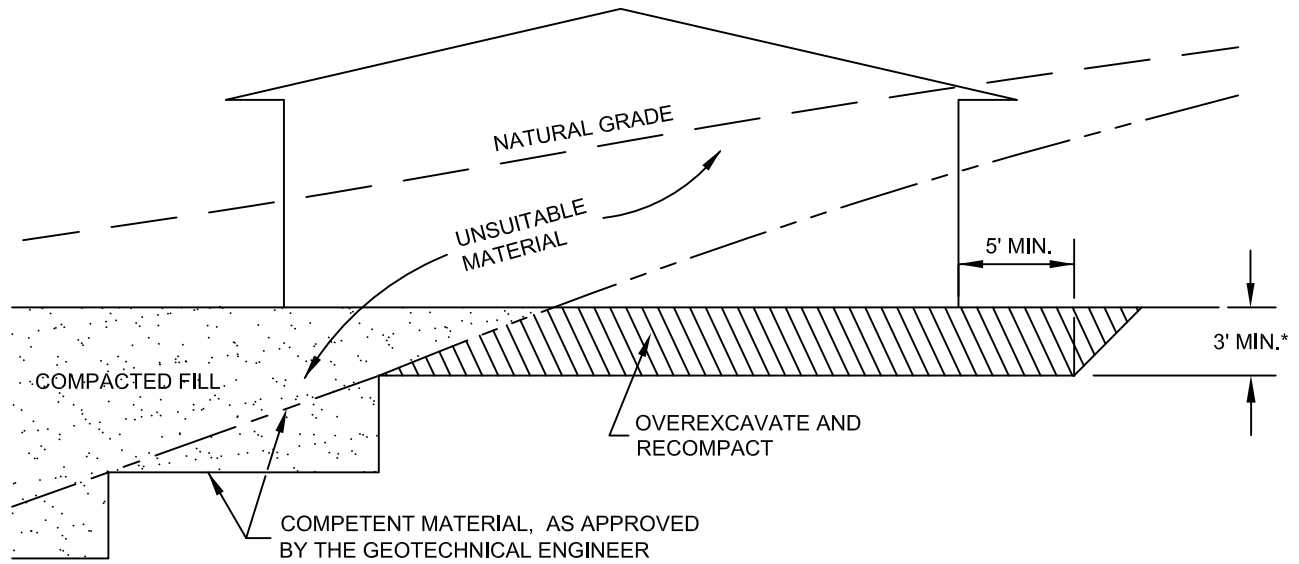

CUT/FILL LOT (TRANSITION)

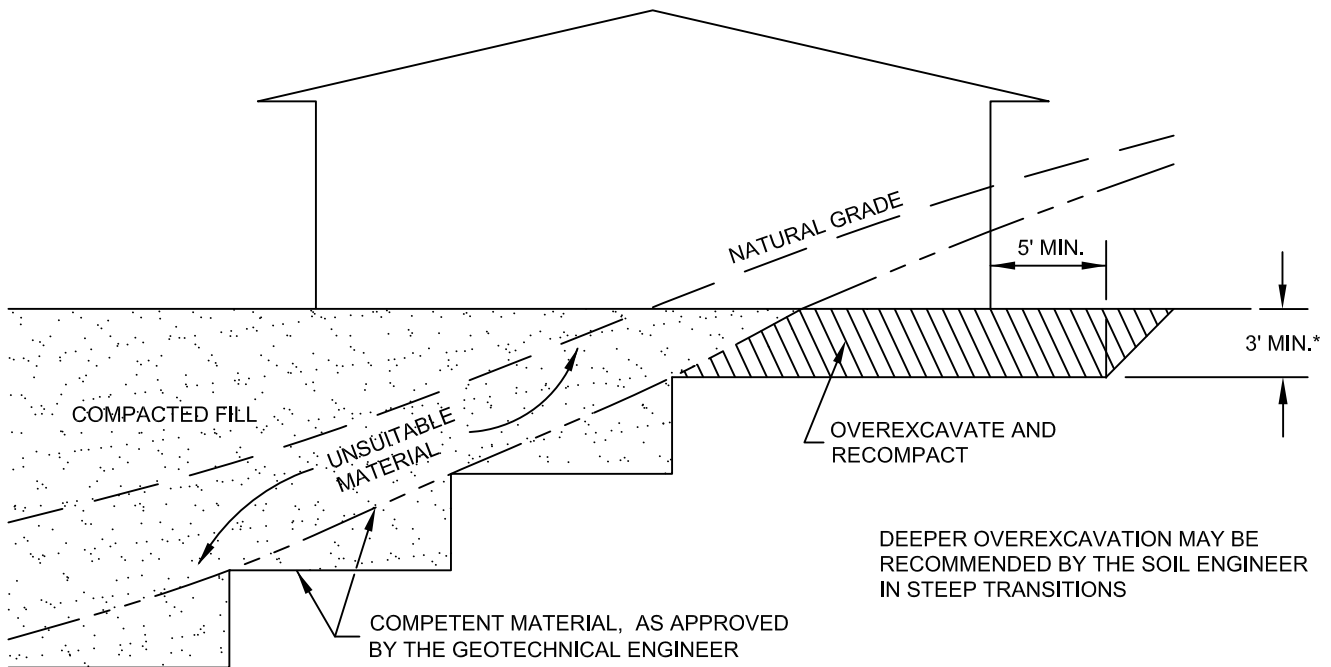

*SEE TEXT OF REPORT FOR SPECIFIC RECOMMENDATION. ACTUAL DEPTH OF OVEREXCAVATION MAY BE GREATER.

TRANSITION LOT DETAIL	
GRADING GUIDE SPECIFICATIONS	
NOT TO SCALE	 SOUTHERN CALIFORNIA GEOTECHNICAL
DRAWN: JAS CHKD: GKM	
PLATE D-1	

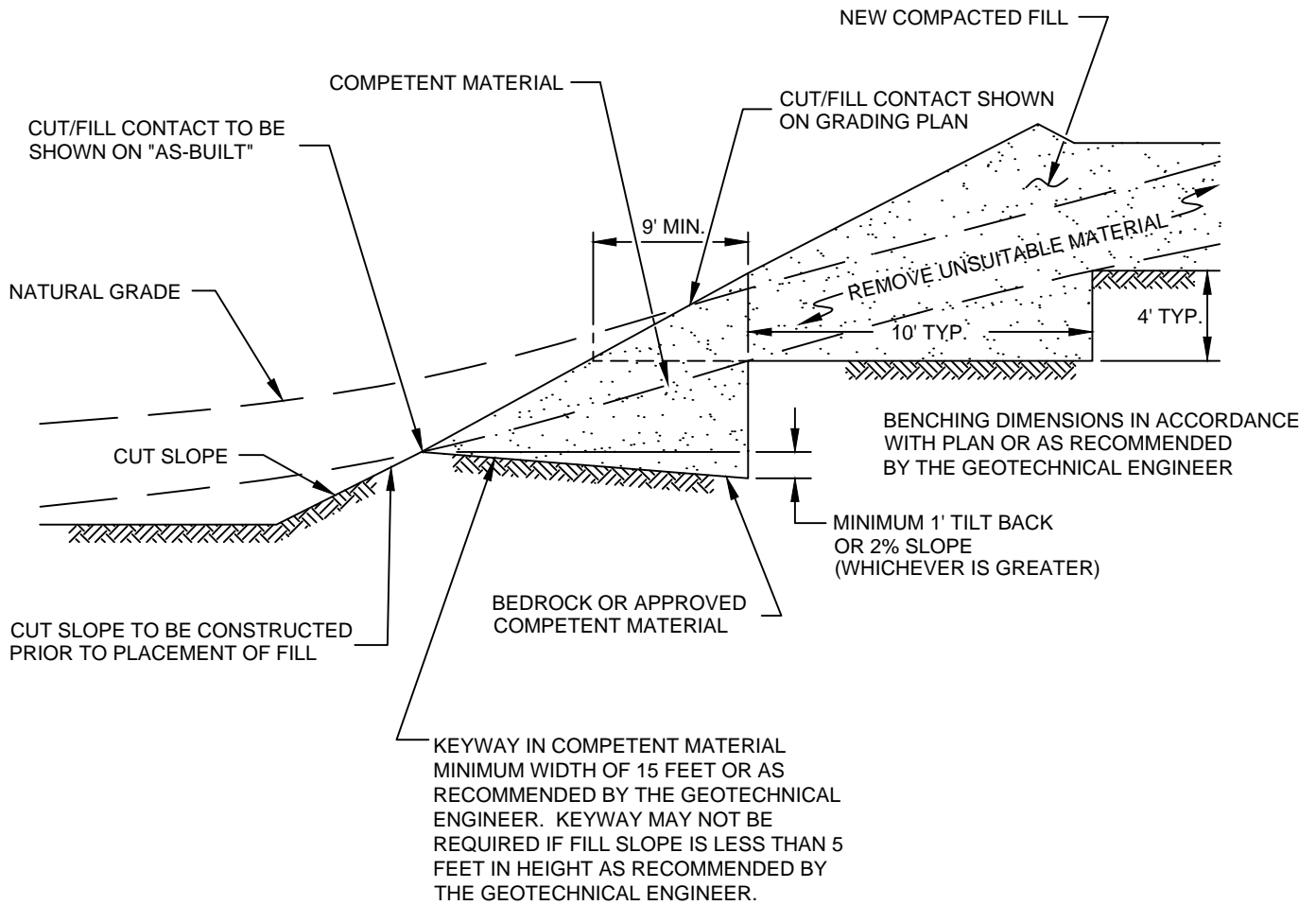

FILL ABOVE CUT SLOPE DETAIL	
GRADING GUIDE SPECIFICATIONS	
NOT TO SCALE	 SOUTHERN CALIFORNIA GEOTECHNICAL
DRAWN: JAS CHKD: GKM	
PLATE D-2	

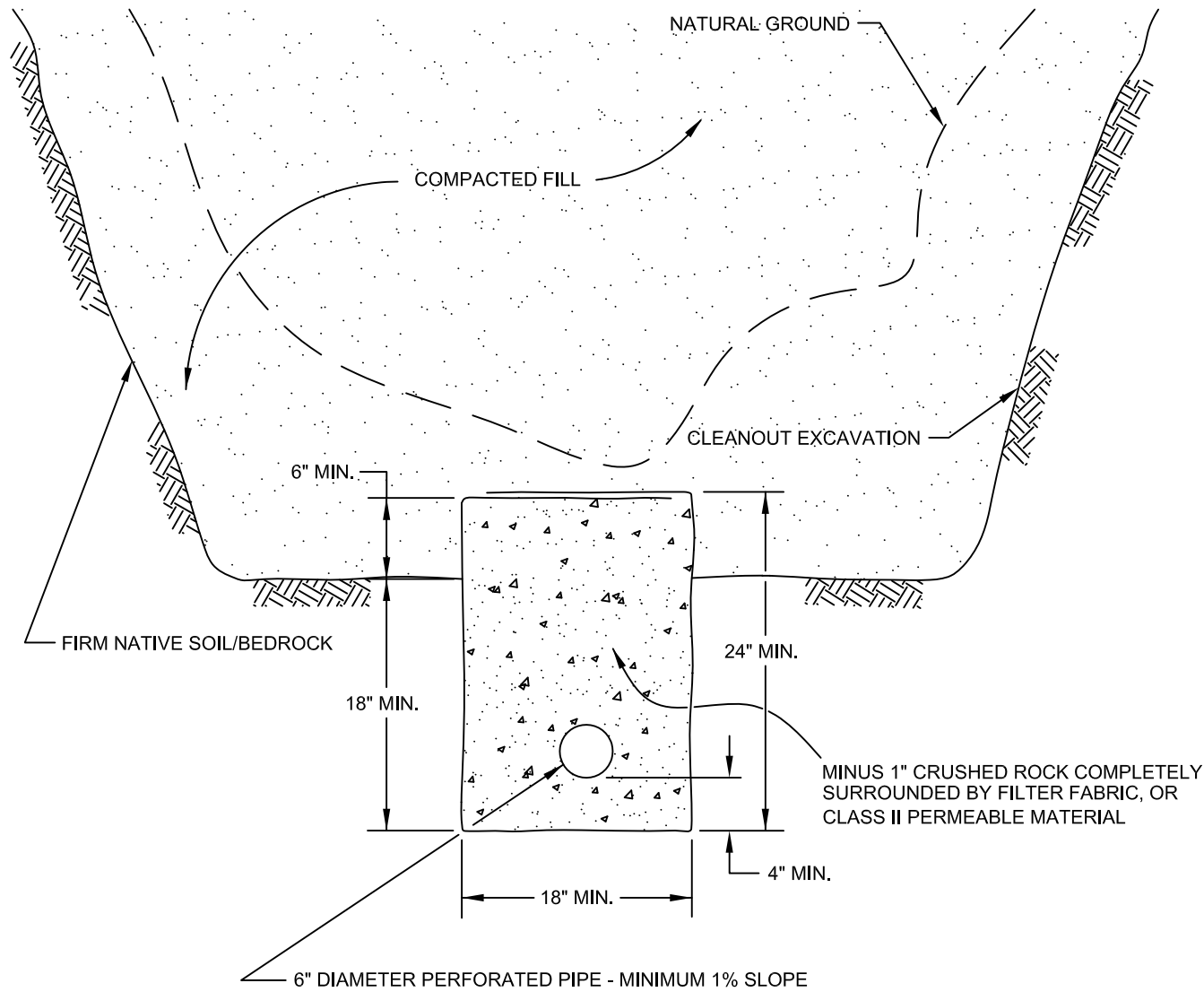

PIPE MATERIAL	DEPTH OF FILL OVER SUBDRAIN
ADS (CORRUGATED POLETHYLENE)	8
TRANSITE UNDERDRAIN	20
PVC OR ABS: SDR 35	35
SDR 21	100

**SCHEMATIC ONLY
NOT TO SCALE**

CANYON SUBDRAIN DETAIL	
GRADING GUIDE SPECIFICATIONS	
NOT TO SCALE	 SOUTHERN CALIFORNIA GEOTECHNICAL
DRAWN: JAS CHKD: GKM	
PLATE D-3	

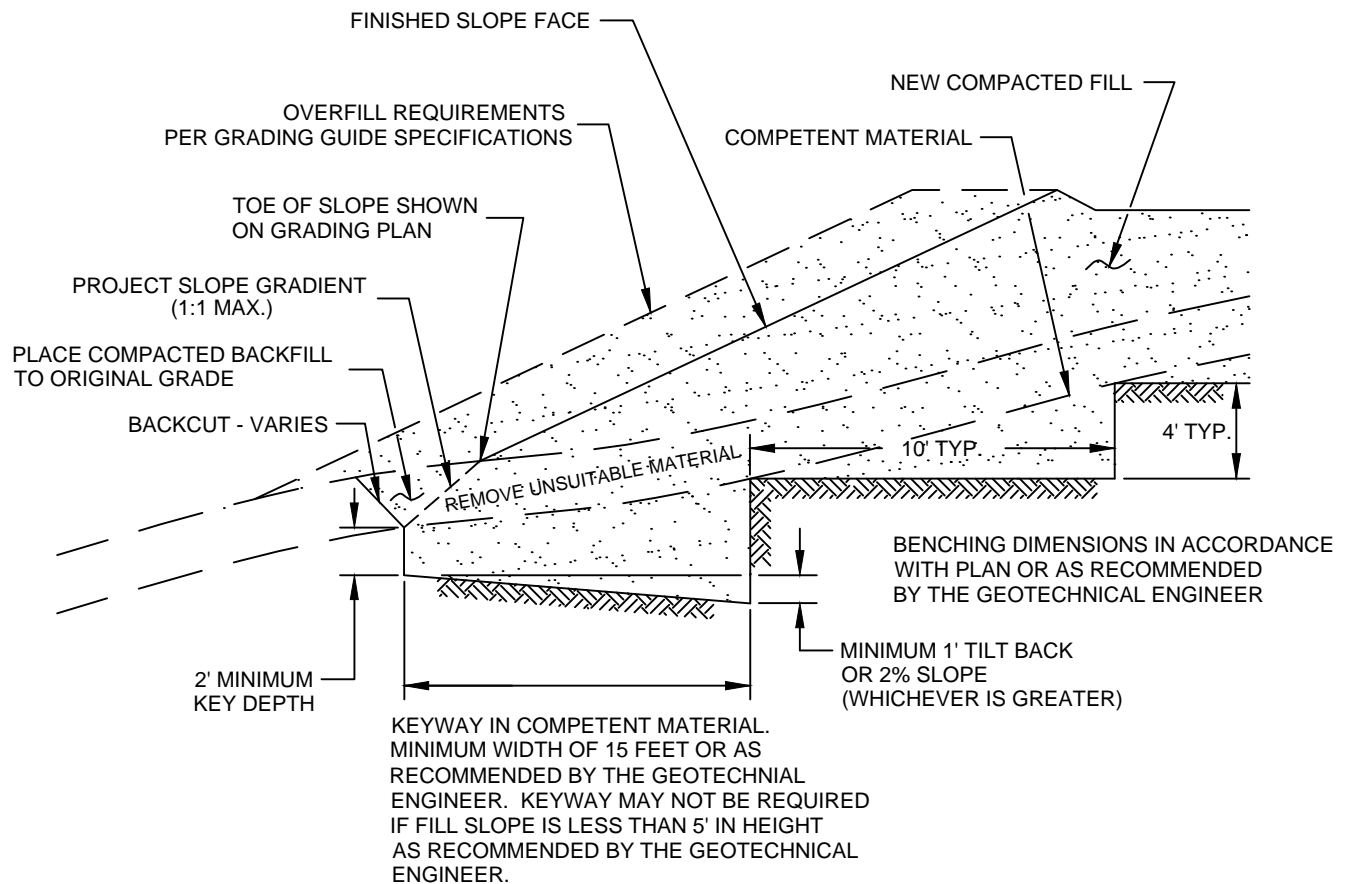

NOTE:
 BENCHING SHALL BE REQUIRED WHEN NATURAL SLOPES ARE EQUAL TO OR STEEPER THAN 5:1 OR WHEN RECOMMENDED BY THE GEOTECHNICAL ENGINEER.

FILL ABOVE NATURAL SLOPE DETAIL	
GRADING GUIDE SPECIFICATIONS	
NOT TO SCALE	
DRAWN: JAS CHKD: GKM	
PLATE D-4	
	SOUTHERN CALIFORNIA GEOTECHNICAL

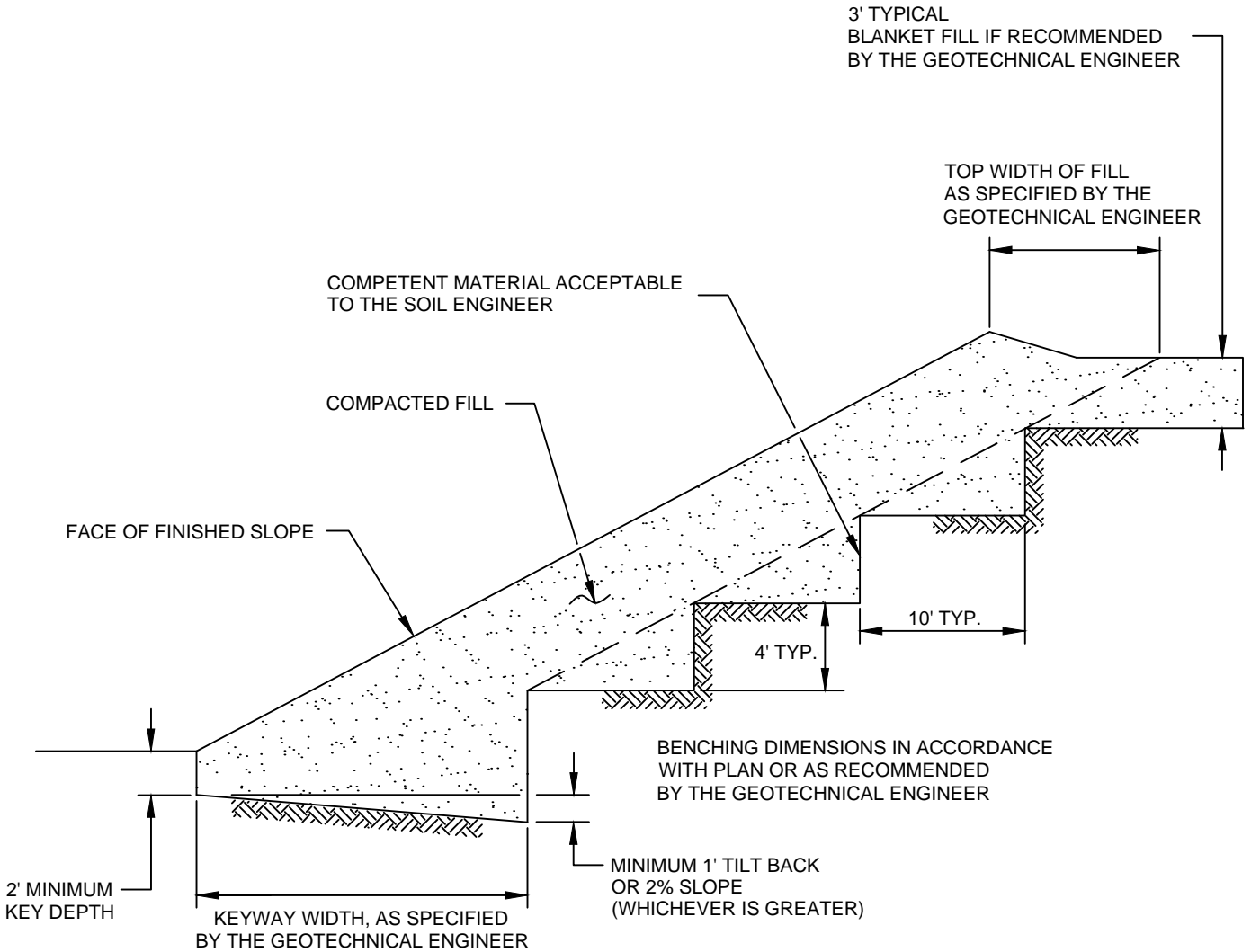

STABILIZATION FILL DETAIL	
GRADING GUIDE SPECIFICATIONS	
NOT TO SCALE	 SOUTHERN CALIFORNIA GEOTECHNICAL
DRAWN: JAS CHKD: GKM	
PLATE D-5	

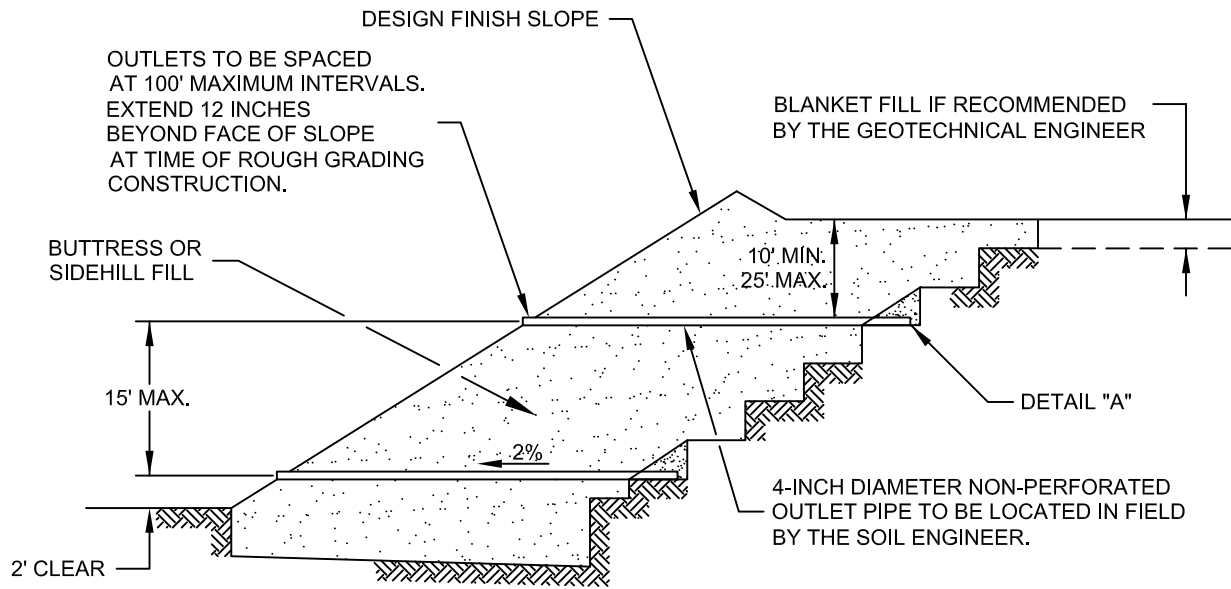

"FILTER MATERIAL" TO MEET FOLLOWING SPECIFICATION OR APPROVED EQUIVALENT: (CONFORMS TO EMA STD. PLAN 323)

SIEVE SIZE	PERCENTAGE PASSING
1"	100
3/4"	90-100
3/8"	40-100
NO. 4	25-40
NO. 8	18-33
NO. 30	5-15
NO. 50	0-7
NO. 200	0-3

"GRAVEL" TO MEET FOLLOWING SPECIFICATION OR APPROVED EQUIVALENT:

SIEVE SIZE	MAXIMUM PERCENTAGE PASSING
1 1/2"	100
NO. 4	50
NO. 200	8
SAND EQUIVALENT = MINIMUM OF 50	

OUTLET PIPE TO BE CONNECTED TO SUBDRAIN PIPE WITH TEE OR ELBOW

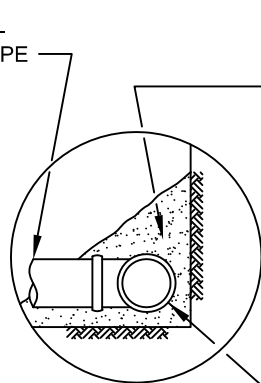

DETAIL "A"

FILTER MATERIAL - MINIMUM OF FIVE CUBIC FEET PER FOOT OF PIPE. SEE ABOVE FOR FILTER MATERIAL SPECIFICATION.

ALTERNATIVE: IN LIEU OF FILTER MATERIAL FIVE CUBIC FEET OF GRAVEL PER FOOT OF PIPE MAY BE ENCASED IN FILTER FABRIC. SEE ABOVE FOR GRAVEL SPECIFICATION.

FILTER FABRIC SHALL BE MIRAFI 140 OR EQUIVALENT. FILTER FABRIC SHALL BE LAPPED A MINIMUM OF 12 INCHES ON ALL JOINTS.

MINIMUM 4-INCH DIAMETER PVC SCH 40 OR ABS CLASS SDR 35 WITH A CRUSHING STRENGTH OF AT LEAST 1,000 POUNDS, WITH A MINIMUM OF 8 UNIFORMLY SPACED PERFORATIONS PER FOOT OF PIPE INSTALLED WITH PERFORATIONS ON BOTTOM OF PIPE. PROVIDE CAP AT UPSTREAM END OF PIPE. SLOPE AT 2 PERCENT TO OUTLET PIPE.

NOTES:

1. TRENCH FOR OUTLET PIPES TO BE BACKFILLED WITH ON-SITE SOIL.

SLOPE FILL SUBDRAINS	
GRADING GUIDE SPECIFICATIONS	
NOT TO SCALE	 SOUTHERN CALIFORNIA GEOTECHNICAL
DRAWN: JAS CHKD: GKM	
PLATE D-6	

MINIMUM ONE FOOT THICK LAYER OF LOW PERMEABILITY SOIL IF NOT COVERED WITH AN IMPERMEABLE SURFACE

MINIMUM ONE FOOT WIDE LAYER OF FREE DRAINING MATERIAL (LESS THAN 5% PASSING THE #200 SIEVE) OR PROPERLY INSTALLED PREFABRICATED DRAINAGE COMPOSITE (MiraDRAIN 6000 OR APPROVED EQUIVALENT).

FILTER MATERIAL - MINIMUM OF TWO CUBIC FEET PER FOOT OF PIPE. SEE BELOW FOR FILTER MATERIAL SPECIFICATION.

ALTERNATIVE: IN LIEU OF FILTER MATERIAL TWO CUBIC FEET OF GRAVEL PER FOOT OF PIPE MAY BE ENCASED IN FILTER FABRIC. SEE BELOW FOR GRAVEL SPECIFICATION.

FILTER FABRIC SHALL BE MIRAFAI 140 OR EQUIVALENT. FILTER FABRIC SHALL BE LAPPED A MINIMUM OF 6 INCHES ON ALL JOINTS.

MINIMUM 4-INCH DIAMETER PVC SCH 40 OR ABS CLASS SDR 35 WITH A CRUSHING STRENGTH OF AT LEAST 1,000 POUNDS, WITH A MINIMUM OF 8 UNIFORMLY SPACED PERFORATIONS PER FOOT OF PIPE INSTALLED WITH PERFORATIONS ON BOTTOM OF PIPE. PROVIDE CAP AT UPSTREAM END OF PIPE. SLOPE AT 2 PERCENT TO OUTLET PIPE.

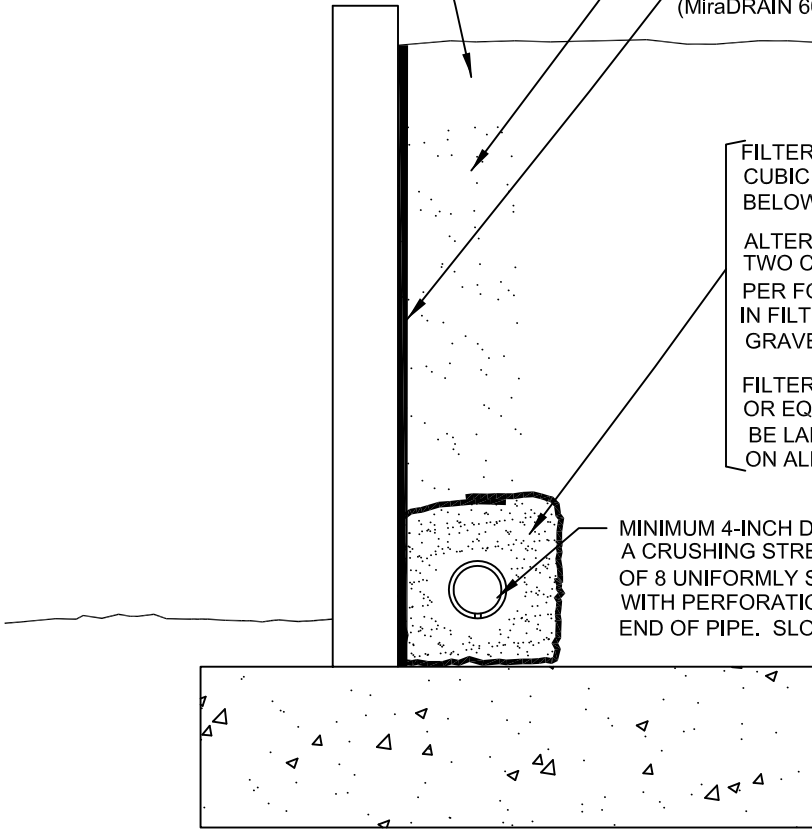

"FILTER MATERIAL" TO MEET FOLLOWING SPECIFICATION OR APPROVED EQUIVALENT: (CONFORMS TO EMA STD. PLAN 323)

SIEVE SIZE	PERCENTAGE PASSING
1"	100
3/4"	90-100
3/8"	40-100
NO. 4	25-40
NO. 8	18-33
NO. 30	5-15
NO. 50	0-7
NO. 200	0-3

"GRAVEL" TO MEET FOLLOWING SPECIFICATION OR APPROVED EQUIVALENT:

SIEVE SIZE	MAXIMUM PERCENTAGE PASSING
1 1/2"	100
NO. 4	50
NO. 200	8
SAND EQUIVALENT = MINIMUM OF 50	

RETAINING WALL BACKDRAINS	
GRADING GUIDE SPECIFICATIONS	
NOT TO SCALE	 SOUTHERN CALIFORNIA GEOTECHNICAL
DRAWN: JAS CHKD: GKM	
PLATE D-7	

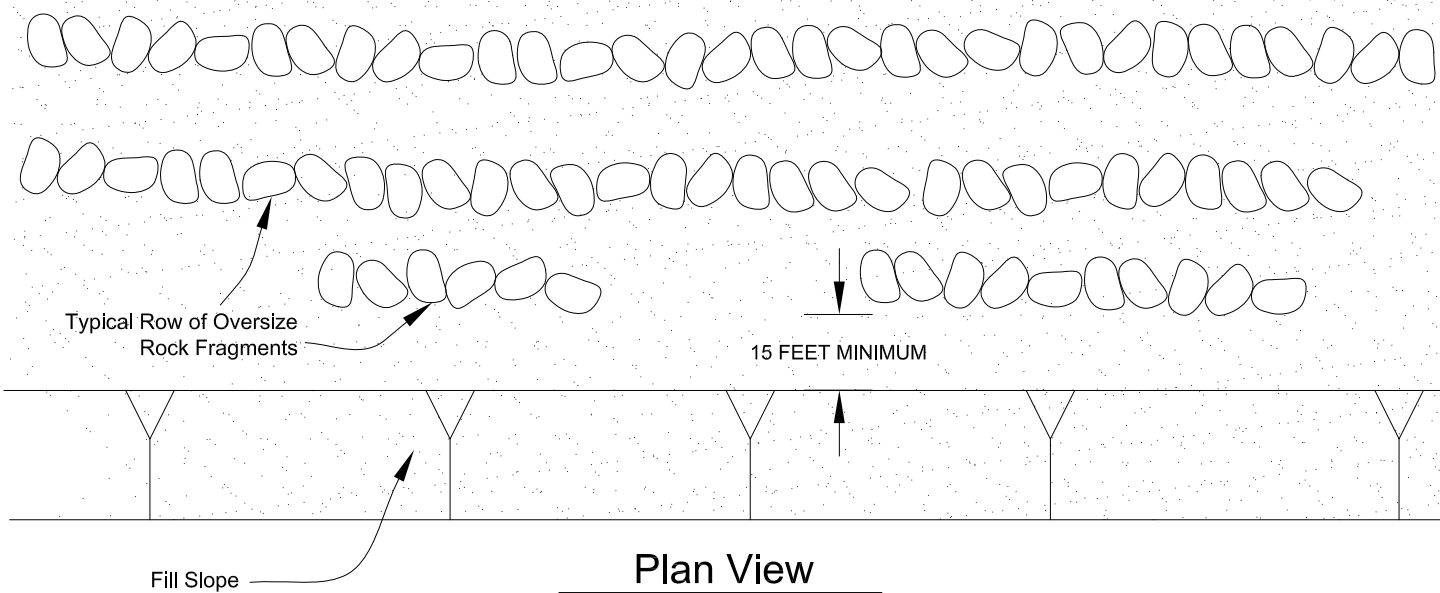
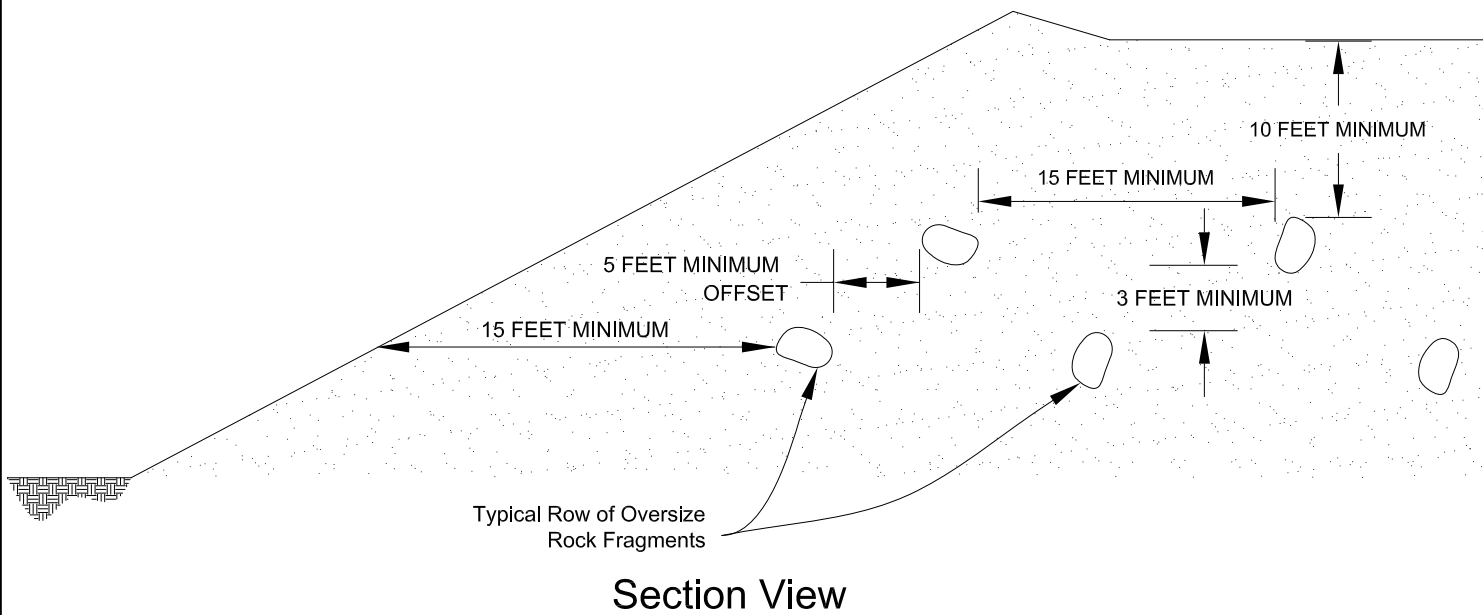

**PLACEMENT OF OVERSIZED MATERIAL
GRADING GUIDE SPECIFICATIONS**

NOT TO SCALE

DRAWN: PM
CHKD: GKM

PLATE D-8



**SOUTHERN
CALIFORNIA
GEOTECHNICAL**

APPENDIX



14050 Day St, Moreno Valley, CA 92553, USA

Latitude, Longitude: 33.9142412, -117.2780826



Date	1/18/2022, 2:11:44 PM
Design Code Reference Document	ASCE7-16
Risk Category	II
Site Class	D - Stiff Soil

Type	Value	Description
S _S	1.5	MCE _R ground motion. (for 0.2 second period)
S ₁	0.6	MCE _R ground motion. (for 1.0s period)
S _{MS}	1.5	Site-modified spectral acceleration value
S _{M1}	null -See Section 11.4.8	Site-modified spectral acceleration value
S _{DS}	1	Numeric seismic design value at 0.2 second SA
S _{D1}	null -See Section 11.4.8	Numeric seismic design value at 1.0 second SA

Type	Value	Description
SDC	null -See Section 11.4.8	Seismic design category
F _a	1	Site amplification factor at 0.2 second
F _v	null -See Section 11.4.8	Site amplification factor at 1.0 second
PGA	0.566	MCE _G peak ground acceleration
F _{PGA}	1.1	Site amplification factor at PGA
PGA _M	0.622	Site modified peak ground acceleration
T _L	8	Long-period transition period in seconds
SsRT	1.691	Probabilistic risk-targeted ground motion. (0.2 second)
SsUH	1.813	Factored uniform-hazard (2% probability of exceedance in 50 years) spectral acceleration
SsD	1.5	Factored deterministic acceleration value. (0.2 second)
S1RT	0.634	Probabilistic risk-targeted ground motion. (1.0 second)
S1UH	0.698	Factored uniform-hazard (2% probability of exceedance in 50 years) spectral acceleration.
S1D	0.6	Factored deterministic acceleration value. (1.0 second)
PGA _d	0.566	Factored deterministic acceleration value. (Peak Ground Acceleration)
C _{RS}	0.932	Mapped value of the risk coefficient at short periods
C _{R1}	0.908	Mapped value of the risk coefficient at a period of 1 s

SOURCE: SEAOC/OSHPD Seismic Design Maps Tool
<<https://seismicmaps.org/>>



SEISMIC DESIGN PARAMETERS - 2019 CBC	
PROPOSED WAREHOUSE	
MORENO VALLEY, CALIFORNIA	
DRAWN: JLL CHKD: RGT SCG PROJECT 21G291-1	 SOUTHERN CALIFORNIA GEOTECHNICAL
PLATE E-1	

APPENDIX

LIQUEFACTION EVALUATION

Project Name	Proposed Warehouse
Project Location	Moreno Valley, CA
Project Number	21G291-1
Engineer	JLL

Design PGA	0.622 (g)
Design Magnitude	6.94
Historic High Depth to Groundwater	14 (ft)
Depth to Groundwater at Time of Drilling	21.5 (ft)
Borehole Diameter	6 (in)

Boring No. B-1

Sample Depth (ft)	Depth to Top of Layer (ft)	Depth to Bottom of Layer (ft)	Depth to Midpoint (ft)	Uncorrected SPT N-Value	Unit Weight of Soil (pcf)	Fines Content (%)	Energy Correction	C_B	C_S	C_N	Rod Length Correction	$(N_1)_{60}$	$(N_1)_{60CS}$	Overburden Stress (σ'_0) (psf)	Eff. Overburden Stress (Hist. Water) (σ'_v) (psf)	Eff. Overburden Stress (Curr. Water) (σ'_v) (psf)	Stress Reduction Coefficient (r_d)	MSF	KS	Cyclic Resistance Ratio (M=7.5)	Cyclic Resistance Ratio (M=6.94)	Cyclic Stress Ratio Induced by Design Earthquake	Factor of Safety	Comments
							(1)	(2)	(3)	(4)	(5)	(6)	(7)				(8)	(9)	(10)	(11)	(12)	(13)		
14.5	0	14	7		120		1.3	1.05	1.1	1.70	0.85	0.0	0.0	840	840	840	0.98	1.02	1.05	0.06	0.06	N/A	N/A	Above Water Table
14.5	14	17	15.5	21	120		1.3	1.05	1.3	1.05	0.85	33.1	33.1	1860	1766	1860	0.95	1.24	1.04	0.77	1.00	0.40	2.46	Nonliquefiable
19.5	17	22	19.5	27	120		1.3	1.05	1.3	0.97	0.95	44.3	44.3	2340	1997	2340	0.93	1.24	1.01	2.00	2.00	0.44	4.54	Nonliquefiable
24.5	22	27	24.5	30	120		1.3	1.05	1.3	0.93	0.95	47.3	47.3	2940	2285	2753	0.90	1.24	0.98	2.00	2.00	0.47	4.25	Nonliquefiable
29.5	27	32	29.5	36	120		1.3	1.05	1.3	0.93	0.95	56.3	56.3	3540	2573	3041	0.88	1.24	0.94	2.00	2.00	0.49	4.10	Nonliquefiable
34.5	32	37	34.5	54	120		1.3	1.05	1.3	0.98	1	94.2	94.2	4140	2861	3329	0.85	1.24	0.91	2.00	2.00	0.50	4.02	Nonliquefiable
39.5	37	39.5	38.3	47	120		1.3	1.05	1.3	0.95	1	79.2	79.2	4590	3077	3545	0.83	1.24	0.89	2.00	2.00	0.50	4.00	Nonliquefiable
39.5	39.5	42	40.8	47	120		1.3	1.05	1.3	0.94	1	78.8	78.8	4890	3221	3689	0.81	1.24	0.87	2.00	2.00	0.50	4.00	Nonliquefiable
44.5	42	44	43	35	120		1.3	1.05	1.3	0.88	1	54.7	54.7	5160	3350	3818	0.80	1.24	0.86	2.00	2.00	0.50	4.01	Nonliquefiable
44.5	44	47	45.5	35	120		1.3	1.05	1.3	0.87	1	54.1	54.1	5460	3494	3962	0.79	1.24	0.85	2.00	2.00	0.50	4.02	Nonliquefiable
49.5	47	50	48.5	49	120		1.3	1.05	1.3	0.94	1	81.9	81.9	5820	3667	4135	0.77	1.24	0.84	2.00	2.00	0.49	4.05	Nonliquefiable

Notes:

- | | |
|---|--|
| (1) Energy Correction for N_{90} of automatic hammer to standard N_{60} | (8) Stress Reduction Coefficient calculated by Eq. 22 (Boulanger and Idriss, 2008) |
| (2) Borehole Diameter Correction (Skempton, 1986) | (9) Magnitude Scaling Factor calculated by Eqns. A.8 & A.10 (Boulanger and Idriss, 2014) |
| (3) Correction for split-spoon sampler with room for liners, but liners are absent, (Seed et al., 1984, 2001) | (10) Overburden Correction Factor calculated by Eq. 54 (Boulanger and Idriss, 2008) |
| (4) Overburden Correction, Calculated by Eq. 39 (Boulanger and Idriss, 2008) | (11) Calculated by Eq. 70 (Boulanger and Idriss, 2008) |
| (5) Rod Length Correction for Samples <10 m in depth | (12) Calculated by Eq. 72 (Boulanger and Idriss, 2008) |
| (6) N-value corrected for energy, borehole diameter, sampler with absent liners, rod length, and overburden | (13) Calculated by Eq. 25 (Boulanger and Idriss, 2008) |
| (7) N-value corrected for fines content per Eqs. 75 and 76 (Boulanger and Idriss, 2008) | |

LIQUEFACTION INDUCED SETTLEMENTS

Project Name	Proposed Warehouse
Project Location	Moreno Valley, CA
Project Number	21G291-1
Engineer	JLL

Boring No. B-1

Sample Depth (ft)	Depth to Top of Layer (ft)	Depth to Bottom of Layer (ft)	Depth to Midpoint (ft)	(N ₁) ₆₀	DN for fines cont	(N ₁) _{60-cs}	Liquefaction Factor of Safety	Limiting Shear Strain γ_{min}	Parameter Fd	Maximum Shear Strain γ_{max}	Height of Layer		Vertical Reconsolidation Strain ϵ_v		Total Deformation of Layer (in)	Comments
				(1)	(2)	(3)	(4)	(5)	(6)	(7)			(8)			
14.5	0	14	7	0.0	0.0	0.0	N/A	0.50	0.95	0.00	14.00		0.000		0.00	Above Water Table
14.5	14	17	15.5	33.1	0.0	33.1	2.46	0.03	-0.30	0.00	3.00		0.000		0.00	Nonliquefiable
19.5	17	22	19.5	44.3	0.0	44.3	4.54	0.00	-1.13	0.00	5.00		0.000		0.00	Nonliquefiable
24.5	22	27	24.5	47.3	0.0	47.3	4.25	0.00	-1.37	0.00	5.00		0.000		0.00	Nonliquefiable
29.5	27	32	29.5	56.3	0.0	56.3	4.10	0.00	-2.11	0.00	5.00		0.000		0.00	Nonliquefiable
34.5	32	37	34.5	94.2	0.0	94.2	4.02	0.00	-5.51	0.00	5.00		0.000		0.00	Nonliquefiable
39.5	37	39.5	38.3	79.2	0.0	79.2	4.00	0.00	-4.12	0.00	2.50		0.000		0.00	Nonliquefiable
39.5	39.5	42	40.8	78.8	0.0	78.8	4.00	0.00	-4.09	0.00	2.50		0.000		0.00	Nonliquefiable
44.5	42	44	43	54.7	0.0	54.7	4.01	0.00	-1.97	0.00	2.00		0.000		0.00	Nonliquefiable
44.5	44	47	45.5	54.1	0.0	54.1	4.02	0.00	-1.93	0.00	3.00		0.000		0.00	Nonliquefiable
49.5	47	50	48.5	81.9	0.0	81.9	4.05	0.00	-4.37	0.00	3.00		0.000		0.00	Nonliquefiable
Total Deformation (in)															0.00	

Notes:

- (1) (N₁)₆₀ calculated previously for the individual layer
- (2) Correction for fines content per Equation 76 (Boulanger and Idriss, 2008)
- (3) Corrected (N₁)₆₀ for fines content
- (4) Factor of Safety against Liquefaction, calculated previously for the individual layer
- (5) Calculated by Eq. 86 (Boulanger and Idriss, 2008)
- (6) Calculated by Eq. 89 (Boulanger and Idriss, 2008)
- (7) Calculated by Eqs. 90, 91, and 92 (Boulanger and Idriss, 2008)
- (8) Volumetric Strain Induced in a Liquefiable Layer, Calculated by Eq. 96 (Boulanger and Idriss, 2008)
(Strain N/A if Factor of Safety against Liquefaction > 1.3)

LIQUEFACTION EVALUATION

Project Name	Proposed Warehouse
Project Location	Moreno Valley, CA
Project Number	21G291-1
Engineer	JLL

Design PGA	0.622 (g)
Design Magnitude	6.94
Historic High Depth to Groundwater	14 (ft)
Depth to Groundwater at Time of Drilling	23 (ft)
Borehole Diameter	6 (in)

Boring No. B-4

Sample Depth (ft)	Depth to Top of Layer (ft)	Depth to Bottom of Layer (ft)	Depth to Midpoint (ft)	Uncorrected SPT N-Value	Unit Weight of Soil (pcf)	Fines Content (%)	Energy Correction	C_B	C_S	C_N	Rod Length Correction	$(N_1)_{60}$	$(N_1)_{60CS}$	Overburden Stress (σ'_0) (psf)	Eff. Overburden Stress (Hist. Water) (σ'_v) (psf)	Eff. Overburden Stress (Curr. Water) (σ'_v) (psf)	Stress Reduction Coefficient (r_d)	MSF	KS	Cyclic Resistance Ratio (M=7.5)	Cyclic Resistance Ratio (M=6.94)	Cyclic Stress Ratio Induced by Design Earthquake	Factor of Safety	Comments
							(1)	(2)	(3)	(4)	(5)	(6)	(7)				(8)	(9)	(10)	(11)	(12)	(13)		
14.5	0	14	7		120		1.3	1.05	1.1	1.70	0.85	0.0	0.0	840	840	840	0.98	1.02	1.05	0.06	0.06	N/A	N/A	Above Water Table
14.5	14	17	15.5	42	120		1.3	1.05	1.3	1.02	0.85	64.7	64.7	1860	1766	1860	0.95	1.24	1.05	2.00	2.00	0.40	4.95	Nonliquefiable
19.5	17	22	19.5	19	120		1.3	1.05	1.3	0.96	0.95	30.9	30.9	2340	1997	2340	0.93	1.21	1.01	0.55	0.67	0.44	1.52	Nonliquefiable
24.5	22	27	24.5	30	120		1.3	1.05	1.3	0.93	0.95	46.8	46.8	2940	2285	2846	0.90	1.24	0.98	2.00	2.00	0.47	4.25	Nonliquefiable
29.5	27	29.5	28.3	28	120		1.3	1.05	1.3	0.90	0.95	42.5	42.5	3390	2501	3062	0.88	1.24	0.95	2.00	2.00	0.48	4.13	Nonliquefiable
29.5	29.5	32	30.8	28	120		1.3	1.05	1.3	0.89	0.95	41.9	41.9	3690	2645	3206	0.87	1.24	0.93	2.00	2.00	0.49	4.07	Nonliquefiable
34.5	32	37	34.5	37	120		1.3	1.05	1.3	0.91	1	59.9	59.9	4140	2861	3422	0.85	1.24	0.91	2.00	2.00	0.50	4.02	Nonliquefiable
39.5	37	42	39.5	41	120		1.3	1.05	1.3	0.92	1	66.6	66.6	4740	3149	3710	0.82	1.24	0.88	2.00	2.00	0.50	4.00	Nonliquefiable
44.5	42	47	44.5	44	120		1.3	1.05	1.3	0.92	1	71.7	71.7	5340	3437	3998	0.79	1.24	0.85	2.00	2.00	0.50	4.02	Nonliquefiable
49.5	47	50	48.5	50	120		1.3	1.05	1.3	0.95	1	83.9	83.9	5820	3667	4229	0.77	1.24	0.84	2.00	2.00	0.49	4.05	Nonliquefiable

Notes:

- | | |
|---|--|
| (1) Energy Correction for N_{90} of automatic hammer to standard N_{60} | (8) Stress Reduction Coefficient calculated by Eq. 22 (Boulanger and Idriss, 2008) |
| (2) Borehole Diameter Correction (Skempton, 1986) | (9) Magnitude Scaling Factor calculated by Eqns. A.8 & A.10 (Boulanger and Idriss, 2014) |
| (3) Correction for split-spoon sampler with room for liners, but liners are absent, (Seed et al., 1984, 2001) | (10) Overburden Correction Factor calculated by Eq. 54 (Boulanger and Idriss, 2008) |
| (4) Overburden Correction, Calculated by Eq. 39 (Boulanger and Idriss, 2008) | (11) Calculated by Eq. 70 (Boulanger and Idriss, 2008) |
| (5) Rod Length Correction for Samples <10 m in depth | (12) Calculated by Eq. 72 (Boulanger and Idriss, 2008) |
| (6) N-value corrected for energy, borehole diameter, sampler with absent liners, rod length, and overburden | (13) Calculated by Eq. 25 (Boulanger and Idriss, 2008) |
| (7) N-value corrected for fines content per Eqs. 75 and 76 (Boulanger and Idriss, 2008) | |

LIQUEFACTION INDUCED SETTLEMENTS

Project Name	Proposed Warehouse
Project Location	Moreno Valley, CA
Project Number	21G291-1
Engineer	JLL

Boring No. B-4

Sample Depth (ft)	Depth to Top of Layer (ft)	Depth to Bottom of Layer (ft)	Depth to Midpoint (ft)	(N ₁) ₆₀	DN for fines cont	(N ₁) _{60-cs}	Liquefaction Factor of Safety	Limiting Shear Strain γ_{min}	Parameter Fd	Maximum Shear Strain γ_{max}	Height of Layer		Vertical Reconsolidation Strain ϵ_v		Total Deformation of Layer (in)	Comments
				(1)	(2)	(3)	(4)	(5)	(6)	(7)			(8)			
14.5	0	14	7	0.0	0.0	0.0	N/A	0.50	0.95	0.00	14.00		0.000		0.00	Above Water Table
14.5	14	17	15.5	64.7	0.0	64.7	4.95	0.00	-2.83	0.00	3.00		0.000		0.00	Nonliquefiable
19.5	17	22	19.5	30.9	0.0	30.9	1.52	0.00	-0.15	0.00	5.00		0.000		0.00	Nonliquefiable
24.5	22	27	24.5	46.8	0.0	46.8	4.25	0.00	-1.34	0.00	5.00		0.000		0.00	Nonliquefiable
29.5	27	29.5	28.3	42.5	0.0	42.5	4.13	0.00	-1.00	0.00	2.50		0.000		0.00	Nonliquefiable
29.5	29.5	32	30.8	41.9	0.0	41.9	4.07	0.01	-0.95	0.00	2.50		0.000		0.00	Nonliquefiable
34.5	32	37	34.5	59.9	0.0	59.9	4.02	0.00	-2.42	0.00	5.00		0.000		0.00	Nonliquefiable
39.5	37	42	39.5	66.6	0.0	66.6	4.00	0.00	-3.00	0.00	5.00		0.000		0.00	Nonliquefiable
44.5	42	47	44.5	71.7	0.0	71.7	4.02	0.00	-3.45	0.00	5.00		0.000		0.00	Nonliquefiable
49.5	47	50	48.5	83.9	0.0	83.9	4.05	0.00	-4.56	0.00	3.00		0.000		0.00	Nonliquefiable
Total Deformation (in)															0.00	

Notes:

- (1) (N₁)₆₀ calculated previously for the individual layer
- (2) Correction for fines content per Equation 76 (Boulanger and Idriss, 2008)
- (3) Corrected (N₁)₆₀ for fines content
- (4) Factor of Safety against Liquefaction, calculated previously for the individual layer
- (5) Calculated by Eq. 86 (Boulanger and Idriss, 2008)
- (6) Calculated by Eq. 89 (Boulanger and Idriss, 2008)
- (7) Calculated by Eqs. 90, 91, and 92 (Boulanger and Idriss, 2008)
- (8) Volumetric Strain Induced in a Liquefiable Layer, Calculated by Eq. 96 (Boulanger and Idriss, 2008)
(Strain N/A if Factor of Safety against Liquefaction > 1.3)